

Varian Vacuum Technologies
121 Hartwell Avenue
Lexington, MA 02421-3133
(781) 861-7200
(800) 8-VARIAN



Linear-Series Gate Valve

Instruction Manual



Manual No. 6999-12-050
Revision F
December 2001

WARRANTY

Products manufactured by Seller are warranted against defects in materials and workmanship for twelve (12) months from date of shipment thereof to Customer, and Seller's liability under valid warranty claims is limited, at the option of Seller, to repair, replacement, or refund of an equitable portion of the purchase price of the Product. Items expendable in normal use are not covered by this warranty. All warranty replacement or repair of parts shall be limited to equipment malfunctions which, in the sole opinion of Seller, are due or traceable to defects in original materials or workmanship. All obligations of Seller under this warranty shall cease in the event of abuse, accident, alteration, misuse, or neglect of the equipment. In-warranty repaired or replacement parts are warranted only for the remaining unexpired portion of the original warranty period applicable to the repaired or replaced parts. After expiration of the applicable warranty period, Customer shall be charged at the then current prices for parts, labor, and transportation.

Reasonable care must be used to avoid hazards. Seller expressly disclaims responsibility for loss or damage caused by use of its Products other than in accordance with proper operating procedures.

Except as stated herein, Seller makes no warranty, express or implied (either in fact or by operation of law), statutory or otherwise; and, except as stated herein, Seller shall have no liability under any warranty, express or implied (either in fact or by operation of law), statutory or otherwise. Statements made by any person, including representatives of Seller, which are inconsistent or in conflict with the terms of this warranty shall not be binding upon Seller unless reduced to writing and approved by an officer of Seller.

Warranty Replacement and Adjustment

All claims under warranty must be made promptly after occurrence of circumstances giving rise thereto, and must be received within the applicable warranty period by Seller or its authorized representative. Such claims should include the Product serial number, the date of shipment, and a full description of the circumstances giving rise to the claim. Before any Products are returned for repair and/or adjustment, written authorization from Seller or its authorized representative for the return and instructions as to how and where these Products should be returned must be obtained. Any Product returned to Seller for examination shall be prepaid via the means of transportation indicated as acceptable by Seller. Seller reserves the right to reject any warranty claim not promptly reported and any warranty claim on any item that has been altered or has been returned by non-acceptable means of transportation. When any Product is returned for examination and inspection, or for any other reason, Customer shall be responsible for all damage resulting from improper packing or handling, and for loss in transit, notwithstanding any defect or non-conformity in the Product, in all cases, Seller has the sole responsibility for determining the cause and nature of failure, and Seller's determination with regard thereto shall be final.

If it is found that Seller's Product has been returned without cause and is still serviceable, Customer will be notified and the Product returned at its expense; in addition, a charge for testing and examination may be made on Products so returned.

VOIDING THE WARRANTY

Linear Gate Valves described in this manual are designed to be used in a clean system. Minute particles such as a piece of lint can seriously affect the ability of the valve to produce a vacuum-tight seal.

Therefore, opening the valve before it is to be used, storing it, or operating it in any environment other than a clean system is considered by Varian Associates as misuse of the equipment and will render the warranty null and void.

When a Linear Gate Valve is used with toxic chemicals, or in an atmosphere that is dangerous to the health of humans, or is environmentally unsafe, it will be the responsibility of the Customer to have the valve cleaned by an independent agency skilled and approved in handling and cleaning contaminated materials before the valve will be accepted by Varian Associates for repair.

Therefore, all details of the Varian "Returned Material Report" (attached) must be complied with including the requirement that a notarized certificate from the cleaning agency certifying that the valve has been cleaned and is harmless to humans and environmentally safe before Varian Associates will accept the returned valve. The certificate must accompany all other shipping papers, including the completed Returned Material Report, and be attached securely to the outside of the box containing the valve. Improper and/or incomplete documentation will result in the unopened, unrepaired valve being returned to the Customer at the Customer's expense.

Varian will ship a replacement valve at no charge to assist the Customer and to minimize downtime. However, if the malfunctioning valve is not returned to Varian within 30 days and meeting all of the requirements of paragraphs 3 and 4 above, then the Customer will be billed for the replacement valve at the then current rate plus shipping charges.

Table of Contents

Section	Page
Section I - Introduction	1-1
1-1 General	1-1
Valve Ordering Information	1-2
Maintenance, spare parts, and accessories	1-2
Technical Specifications	1-3
Section II - Installation	2-1
2-1 Unpacking	2-1
2-2 Installation	2-1
2-2-1 Mounting Orientation	2-1
2-2-2 Mechanical Connections	2-1
2-2-3 Air/electrical Connections	2-1
Section III - Operation	3-1
3-1 Manually-Operated Valves	3-1
3-2 Pneumatically-Operated Valves	3-1
Section IV - Service	4-1
4-1 Maintenance, Actuators	4-1
4-1-1 Manual Valves	4-1
4-1-2 Pneumatic Valves	4-1
4-2 Removing the valve for service	4-6
4-2-1 Disassembly, Carriage mechanism	4-6
4-2-2 Cleaning	4-7
4-2-3 Assembly, Carriage mechanism	4-7
4-2-4 Valve Assembly	4-8
4-3 Position Indicator (Remote)	4-9
4-3-1 Disassembly	4-9
4-3-2 Replacing Microswitches	4-10
4-3-3 Electrical Connections for Microswitches	4-10
4-3-4 Electrical Connections for Connector	4-10
4-3-5 Reassembly	4-11
4-3-6 Removal of Position Indicator from Valve	4-12
4-3-7 Installing the Remote Position Indicator onto the Valve	4-12

List of Illustrations

Figure		Page
Figure 1, Sheet 1	Pneumatic Linear Series Gate Valve Assembly (2½ inch valve shown)	4-2
Figure 1, Sheet 2	Manual Linear Series Gate Valve Assembly 1½ inch valve shown)	4-4
Figure 2, Sheet 1	Carriage Mechanism (2½ inch valve shown)	4-8
Figure 2, Sheet 2	Carriage Mechanism (1½ inch valve shown)	4-9
Figure 3	Typical Position Indicator Assembly	4-11
Figure 4	Set Screw Height Adjustment	4-14

SECTION I

INTRODUCTION

1-1 GENERAL

The Varian linear-series gate valves are designed for use in high- and ultrahigh- vacuum applications where reliable, dry-lubricated mechanisms are required. They operate at pressures from atmosphere to 10^{-9} Torr, depending on the model selected, and provide optimum conductance for a given flange size. The valves feature a positive lock over-center mechanism which is guided in and out of position by hardened steel needle bearing surfaces. The valve bodies are made of stainless steel and are vacuum-furnace brazed. A visual position indicator is supplied as standard equipment with each valve; an optional remote position indicator is available for both hand-operated and air-operated valves which can be easily assembled onto the valve.

The linear-series gate valves are designed to be bakeable in the open position to 200°C (392°F) for extended periods of time. The metal bonnet version features less vacuum-exposed Viton than its Viton-sealed counterpart. This will facilitate a cleaner process environment and decrease the pump-down time and system bake. A Kalrez main seal is also available where baking temperatures to 250°C are required.

The pneumatic valves, including the pneumatic actuator, can be baked in the open position to 200°C (392°F). This allows installation in places that formerly were reserved for manually-actuated valves due to the inability of the pneumatic actuator to survive temperatures above 125°C (258°F).

The solenoid valve is rated for a 55°C (131°F) rise and therefore must be remotely mounted out of the high temperature zone. For this reason, Varian has elected not to mount the solenoid; the user must select fittings of his preference and mount it according to his needs. Varian recommends 1/4 inch OD stainless steel or copper tubing with flairless fittings available from any tube fitting supplier. All of the threaded ports in the air cylinder and solenoid valves are 1/8-27 FNPT.

The optional remote position indicator provides an electrical signal to a remote location such as a system control panel. The position indicator utilizes two SPDT contact switches; one is tripped when the valve is closed, the other is tripped when the valve is open. The switches are rated for 125/250 VDC at 5 amperes. The remote position indicator option may also be used on manual valves.

ORDERING INFORMATION

	1½ Inch Order No.	2½ Inch Order No.
Manually-operated with visual position indicator		
ConFlat flanges, metal bonnet seal, and Viton main seal	L8500301	L8560301
ConFlat flanges, metal bonnet seal, and Kalrez main seal	L8500302	L8560302
KF 40 flanges, Viton bonnet seal, and Viton main seal	L8500303	
LF63 flanges, Viton bonnet seal, and Viton main seal		L8560303
Pneumatically-operated with visual position indicator		
ConFlat flanges, metal bonnet seal, and Viton main seal	L8500304	L8560304
KF 40 flanges, Viton bonnet seal, and Viton main seal	L8500305	
LF63 flanges, Viton bonnet seal, and Viton main seal		L8560305
Pneumatically-operated with remote position indicator		
ConFlat flanges, metal bonnet seal, and Viton main seal	L8500306	
KF 40 flanges, Viton bonnet seal, and Viton main seal	L8500307	
LF63 flanges, Viton bonnet seal, and Viton main seal		
Solenoid valves (Option)		
120/110 volts, 60/50 Hz		626771170
240/220 volts, 60/50 Hz		626771171
24 VDC		626771172
Remote position indicator (Option)	L8524301	L8615301
Maintenance and spare parts		
Seal Kit (standard)	L8631301	L8666301
(includes Viton main seal O-ring, and Viton bonnet seal)		
Seal kit (metal bonnet seal)	L8631302	L8666302
(includes Viton main seal O-ring, and OFHC copper bonnet seal)		
Seal kit (Kalrez)	L8631303	L8666303
(includes Kalrez main seal O-ring, and OFHC copper bonnet seal)		
Pneumatic cylinder rebuild kit	L8633301	L8667301
(includes Viton piston, lubricant, piston shaft O-ring, and cylinder O-ring)		
Carriage mechanism rebuild kit	L8632301	L8668301
(includes copper washers, bearings, E clips, connecting links, and compression spring)		
Dupont Krytox® GPL207 vacuum grease		695400010
Fel-Pro C-100 High-temperature lubricant		9530031
Accessories		
2¾ inch ConFlat gaskets (10/pkg)	953-5091	
4½ inch ConFlat gaskets (10/pkg)		9535093
KF 40 Center ring assembly with Viton O-ring	800-0340	
KF 40 clamp with ratchet closure	800-0140	

TECHNICAL SPECIFICATIONS

Valve Design Life	50,000 cycles
Vacuum Range	Atmosphere to 10^{-9} Torr
Leak Rate	Main seal less than 2×10^{-10} std cc/sec helium with 15 psi differential either direction. Body and bellows less than 2×10^{-10} std cc/sec helium with 15 psi differential either direction.
Maximum Pressure	15 psi differential
Bakeout Temperature	Open 200°C (Kalrez to 250°C); closed 125°C Pneumatic actuator = 200°C (with remotely-mounted solenoid)
Manual Actuator	Nominally 13 turns to open - 1½ inch valve Nominally 25 turns to open - 2½ inch valve
Electro-pneumatic Actuator	120/110 VAC, 60/50 Hz (optional) 240/220 VAC, 60/50 Hz (optional) 24 VDC (optional) 50 to 100 psi air required to open and close
Time to open or close	Nominally 2 seconds
Loss of power	If valve is open and air pressure is applied, valve will close on loss of electrical power. On loss of both electrical power and air pressure, gravity controls the position of the gate. If valve is closed, it will remain closed.
Main Seal	Viton (standard) Kalrez (optional)
Body and primary internal parts	300 series stainless steel
Flanges (1½ inch valve)	2¾ inch ConFlat (1½ inch ID) KF 40 Flange (1½ inch ID)
Flanges (2½ inch valve)	4½ inch ConFlat (2½ inch ID) LF63 Flange (2¾ inch ID)
Lubrication exposed to vacuum	Molydisulfide, Dupont Krytox® GPL207 vacuum lubricant
Mounting position	Any
Weight	7 pounds (1½ inch valve) 18 pounds (2½ inch valve)

SECTION II

INSTALLATION

2-1 UNPACKING

Unpack the valve from the shipping container and inspect it for obvious damage. Retain the shipping container for evidence and call the carrier. If practical, inspect the valve without removing it from its plastic bag. Protect the valve before and during installation. Make sure that machined surfaces, gasket grooves, and valve interior surfaces remain clean and that no foreign matter enters the valve.

If not required for immediate installation and use, repack the valve carefully and store it until it is required. The valve should be stored in an environment which will prevent condensation in the valve.

2-2 INSTALLATION

2-2-1 Mounting Orientation

The valve can be operated in any orientation; the side closest to the seal plate should be the high pressure side. The pneumatic actuator should not be energized to open the valve when there is a high pressure on either side and vacuum on the opposite side.

2-2-2 Mechanical Connections

Before beginning the actual installation, check for operational accessibility and for access to the valve for maintenance. Place the valve into position, making sure that the mechanical connections are compatible. For example, check to determine that all mating flanges meet, are parallel and that no strain will be placed on any of the mating components when the flanges are properly mated, and that the mounting bolt holes are properly aligned.

- 1 Remove the valve from the plastic shipping bag.
- 2 On valves equipped with ConFlat flanges, apply a high-temperature lubricant (Fel-Pro C-100 or equivalent) on the connecting bolt threads to prevent galling.
- 3 Bolt the flanges together, tightening around the bolt circle three times at torque values shown in the following table to bring the flanges squarely face to face.

Typical Torque Reading (ft-lbs)

Flange OD	1st Pass	2nd Pass	3rd Pass
1 $\frac{1}{3}$ "	1	2	3.5 max.
2 $\frac{3}{4}$ "	5	10	16 max.
3 $\frac{3}{8}$ " to 10"	5	10	26 max.

2-2-3 Air/Electrical Connections

The valves are set up at the factory to operate at air pressures from 50 to 100 psig. Air inlet to the solenoid valve is $\frac{1}{8}$ -27 FNPT. The solenoid is actuated by a 120/110 VAC, 60/50 Hz source (optional: 240/220 VAC, 60/50 Hz, and 24 VDC).

SECTION III

OPERATION

3-1 MANUALLY-OPERATED VALVE

The manual valve operates by means of a hand-actuated knob. Turn the knob in a clockwise direction to close the valve. To obtain a good vacuum seal, turn the knob clockwise until a slight resistance is felt, then continue turning the knob another $\frac{1}{2}$ to $\frac{3}{4}$ turn. This will lock the mechanism in the over-center position. To open the valve, turn the knob counterclockwise until the valve is fully open to ensure maximum conductance.

3-2 PNEUMATICALLY-OPERATED VALVE



WARNING

Keep fingers and hands out of the gate opening at all times when the air supply lines are connected to the valve. The valve could unexpectedly close resulting in serious injury to the operator.

The pneumatically-actuated valves are air-opened, air-closed. When electrical power is applied to the solenoid, air is supplied to the pneumatic cylinder and the valve opens. When the electrical power is removed, air is supplied to the opposite side of the pneumatic cylinder and the valve closes. If the valve is already closed, it will remain so if there is a loss of power to the valve and the air supply is removed.

SECTION IV

SERVICE

4-1 MAINTENANCE, ACTUATORS

4-1-1 Manual Valves (See Figure 1, Sheets 2)

The stem screw has been lubricated with Fel-Pro C-100 (Varian part no. 9530031). After several bakeouts, the stem screw should be lightly relubricated with Fel-Pro C-100. Open and close the valve several times to distribute the lubricant.

4-1-2 Pneumatic Valves (See Figure 1, Sheets 1)

Periodic maintenance of the pneumatic air cylinder will be required after every 300 to 500 hours of baking. The O-rings (10 and 13) and the piston (11) should be replaced and lubricated after 300 to 500 hours of baking, or if an air leak is detected at the exhaust port of the solenoid valve. A pneumatic cylinder repair kit, including parts and lubricant (Varian part no. 1281L8633301) is available. This maintenance can be done without breaking the vacuum in the following manner.

- 1 Close the valve to the latched position.
- 2 Disconnect the air lines.
- 3 Remove four screws (16).
- 4 Remove the air cylinder cap (8) and the air cylinder (9).
- 5 Remove the screw (12) and the piston (11).
- 6 Remove the cylinder base (7).
- 7 Carefully remove the O-rings from the cylinder base and the cylinder cap; do not scratch the O-ring sealing surfaces.
- 8 Clean parts with Alcohol degreasing solvent.
- 9 Lubricate O-rings with lubricant provided in the repair kit.
- 10 Apply lubricant to the O-ring (13) and install it into the groove on the inside diameter of the cylinder base (7). Fill the remainder of the groove with lubricant. Apply a thin coat of lubricant to the O-rings (10) and insert them into the O-ring groove in the cylinder base. Assemble the cylinder base to the piston rod assembly.
- 11 Apply a thin coat of lubricant to the inside of the cylinder (9). Hold the center of the piston between the index finger and thumb. Apply a bead of lubricant approximately $\frac{1}{4}$ -inch wide by $\frac{1}{8}$ -inch high to the cup area of the piston. Insert the lubricated piston (as held between the index finger and thumb) into the approximate center of the cylinder. Once centered, rotate the piston into position inside the cylinder. A small amount of lubricant will be squeezed out while rotating the piston. Use this excess to re-lubricate the inside of the cylinder.
- 12 Apply a generous amount of Loctite 242 to the screw (12).
- 13 Insert the screw (12) onto the metal side of the piston.
- 14 Install the air cylinder and piston onto the piston rod (the rubber side of the piston mating to the rod) using the screw (12). BE CAREFUL NOT TO DISTORT THE BELLOWS WHEN TIGHTENING THE SCREW (12).

- 15 Apply a thin coat of lubricant to the O-ring (10) and insert it into the O-ring groove in the cylinder cap.
- 16 Assemble the cylinder cap to the air cylinder. Install four screws (16), lock washers (14), and nuts (15), and tighten evenly.

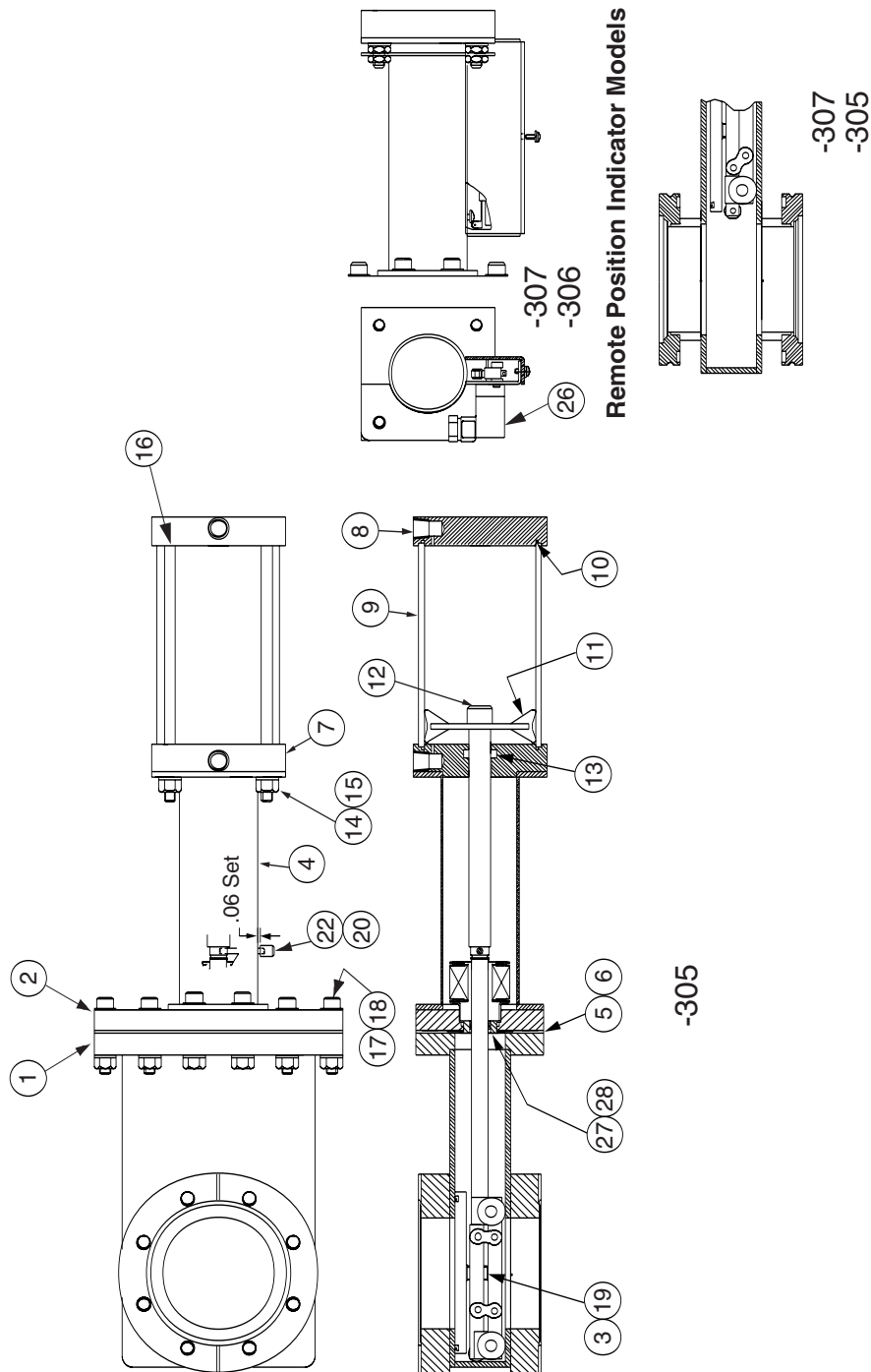

Figure 1, Sheet 1. Pneumatic Linear Series Gate Valve Assembly (2½ inch valve shown)

PARTS LIST

Pneumatic Linear-Series Gate Valves

Item	Description	1½ Inch Order No.	2½ Inch Order No.
1	Body Assy (-304 & -306)	L8510301	L8561301
	Body Assy (-305 & -307)	L8521301	L8563301
2	Bellows Assy	L8531301	L8539301
3	Carriage Assy	L8501301	L8551301
4	Bellows Cylinder Assy	L8509301	L8548301
5	Gasket, Metal Bonnet Seal (-304 & -306)	L8540001	L8566001
	O-Ring, Viton (-305 & -307) Coml	2-139	2-153
6	Spacer, Metal Bonnet Seal (-304 & -306)	L8530001	L8565301
	Gasket, Flange (-305 & -307)	L8514001	L8635001
7	Transition Flange	L8535001	L8649001
8	End Plate	L8534001	L8648001
9	Pneumatic Cylinder	L8533001	L8538001
10	O-Ring, Viton, Coml	2-033	2-037
11	Viton Piston	660203145	660203142
12	Screw, Socket hd cap, 3/8-16 x 1/2 inch lg	Coml	Coml
13	O-Ring, Viton, Coml	2-206	2-206
14	Nut, Hex, 1/4-20, sst	Coml	Coml
15	Washer, Lock, sst	Coml	Coml
16	Screw, Socket hd cap	1/4-20 x 4 1/2	1/4-20 x 6
17	Screw, Socket hd cap, sst	1/4-20 x 1 1/2	1/4-20 x 1 1/2
18	Washer, Flat, sst	Coml	
19	Pin, Roll	616520185	612520190
20	Cap, Position Indicator	L8525001	
22	Screw, Set	6-32 x 1 1/4	6-32 x 1 1/4
26	Position Indicator Assembly	L8524301	L8615301
27	Bearing Assy	Not Required	L8611301
28	Bearing	Not Required	660110103

Coml - Commercially available

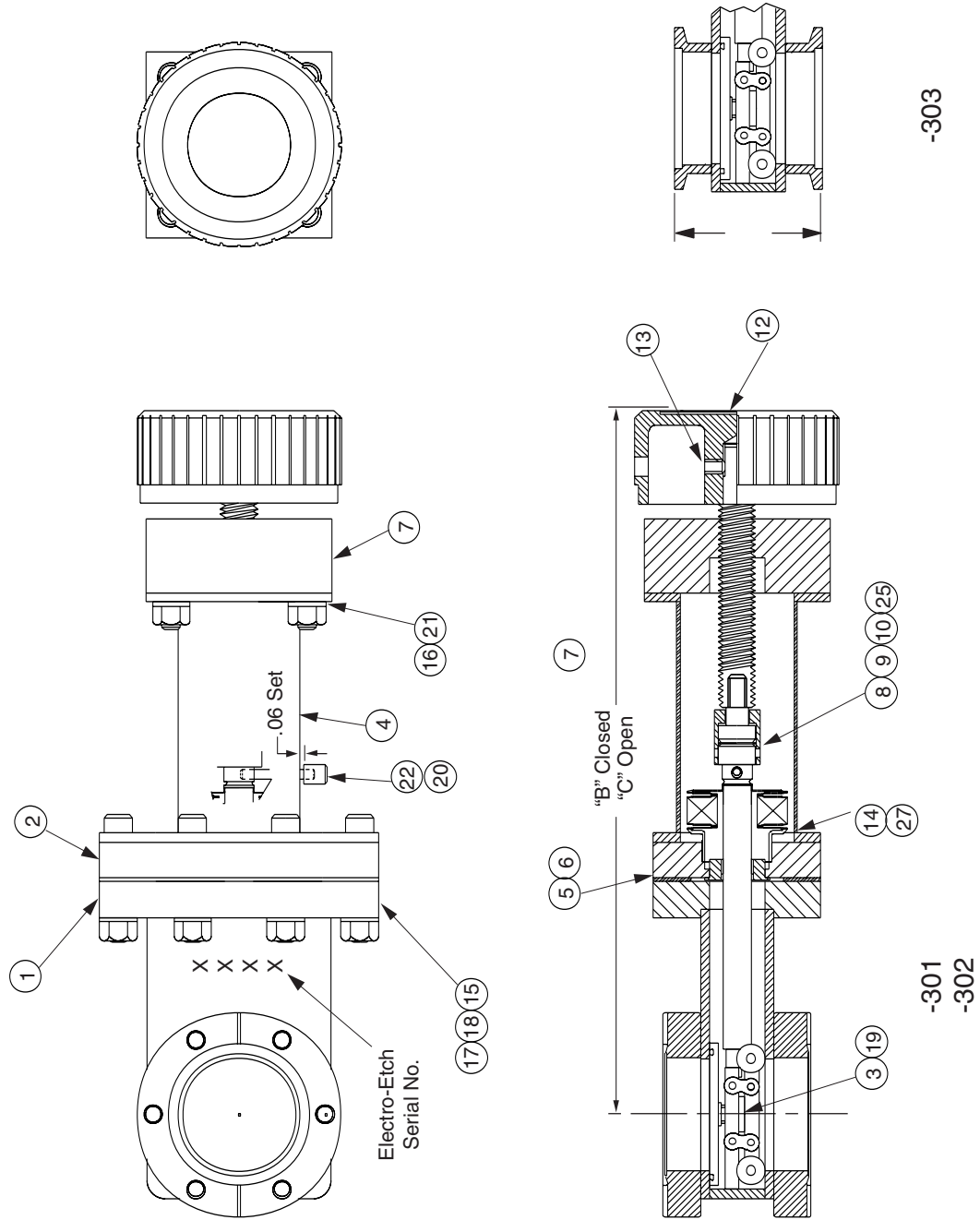

Figure 1, Sheet 2. Manual Linear Series Gate Valve Assembly (1 1/2 inch valve shown)

PARTS LIST

Manual Linear-Series Gate Valves

Item	Description	Order No.	Order No.
1	Body Assy (-301 & -302)	L8510301	L8561301
	Body Assy (-303)	L8521301	L8563301
2	Bellows Assy	L8541301	L8614301
3	Carriage Assy (-301 & -303)	L8501301	L8551301
	Carriage Assy (-302)	L8501302	L8551302
4	Bellows Cylinder Assy	L8509301	L8548301
5	Gasket, Metal Bonnet Seal (-301 & -302)	L8540001	L8566001
	O-Ring, Viton, 2-139 (-303)	2-139	2-153
6	Spacer, Metal Bonnet Seal (-301 & -302)	L8530001	L8565001
	Gasket, Flange (-303)	L8514001	L8635001
7	End Cap	L8547001	L8651001
8	Coupling	L8545001	L8545001
9	Screw, Shoulder	611904130	6119040130
10	Roll Pin	616520212	616520212
11	Screw, Stem	L8543001	L8613001
12	Knob	L5968001	L8968001
13	Screw, Set	613220250	613220250
14	Bearing	L8546001	L8611301
15	Nut, Hex, 1/4-20, sst	Coml	Coml
16	Washer, Lock, sst	Coml	Coml
17	Screw, Socket hd cap, 1/4-20 x 1-1/2 inches lg, sst	Coml	Coml
18	Washer, Flat, sst	Coml	Coml
19	Pin, Roll	616520185	616520190
20	Cap, Position Indicator	L8525001	L8525001
21	Screw, Socket hd cap, 1/4-20 x 1 1/4 inches lg, sst	Coml	Coml
22	Screw, Set, No. 6-32 x 1 1/4 inches lg	Coml	Coml
25	Washer, Thrust	Q2280001	Q2280001
27	DU Bearing	660110103	660110103

Coml - Commercially available

4-2 REMOVING THE VALVE FOR SERVICE

The valve can be serviced without removing the body from the system; however, the valve must not be under a vacuum.

- 1 Retract the valve mechanism to the open position, disconnect the air pressure, and disconnect electrical power.



CAUTION

In the following step, the electro-pneumatic valve must be in the open position to safely disassemble it. Since the valve will close upon the loss of electrical power, it is important to disconnect air pressure first, then electrical power. Upon removal of air pressure, the seal plate may occupy a position between fully open and fully closed due to the natural springiness of the bellows.



NOTE

In the following step, the engraving on the valve and the main seal O-ring should be **facing the operator** when removing the bonnet assembly from the valve.

- 2 Remove the bolts (17) and nuts from the rectangular flange (2) and remove the bonnet assembly from the body. Be careful while withdrawing the mechanism from the body so as not to scuff the main seal O-ring. Removing the mechanism from the body will free two loose parts; the outer gasket retainer (6) and the bonnet O-ring (5). These parts should be stored in a plastic bag for reassembly of the valve if they are to be reused.

4-2-1 Disassembly - Carriage Mechanism, See Figure 2, Sheets 1 and 2

- 1 Remove the O-ring from the seal plate. Insert a toothpick or other soft pointed device into the vent counterbore of the O-ring groove and pry the O-ring out. Be careful not to scratch or damage the bottom of the groove.



WARNING

In the following step, the sudden release of spring pressure or careless handling can result in injury to personnel.

- 2 Remove the compression spring (8) by inserting a small, flat head screwdriver between a coil closest to the seal mounting disc (2) and compress the spring so that it can be released. Hold the spring between the thumb and forefinger while sliding the spring out of the carriage assembly.
- 3 Remove the spring clips (9) from the four connecting links.
- 4 Push the connecting links out of the carriage assembly.

- 5 Remove the E clips (7) from the axles on the carriage casting and slide off the bearing washers (12) and bearings (6).
- 6 The carriage mechanism is now disassembled.

4-2-2 Cleaning

Once the valve has been disassembled, the metal components can be cleaned using Alcohol.

4-2-3 Assembly - Carriage Mechanism, See Figure 2, Sheets 1 and 2

- 1 Assemble the bearing washers (12), bearing (6), and retaining clip (“E” clip) (7) on each axle of the carriage. When installing the retaining clip, place the side with the rounded edges next to the bearing. Check that each bearing spins freely.
- 2 Assemble the seal mount disc (2) to the carriage using the connecting links. Install the connecting links so that the spring clip can be snapped into position on the same side on which the bearing retaining clips are installed.
- 3 Install the compression spring (8) between the valve shaft and the seal mount disc.
- 4 Clean the seal plate and groove with a lint-free wipe and Alcohol. Lightly grease the O-ring with Dupont Krytox® GPL207 vacuum lubricant (Varian part no. 695400010), just enough to make the O-ring shine.

PARTS LIST

Carriage Assembly - 2½ Inch Linear Series Gate Valves

Item	Description	Order No.
1	Lower Carriage, Machined	L8553001
2	Upper Carriage, Machined	L8552001
3	Seal Disc	L8555001
4	Roller Pin	L8554001
5	Bearing Sleeve	L8564001
6	Bearing, Needle	660114621
7	Retaining Clip	699992430
8	Compression Spring	660285054
9	Connection Link	660217020
10	Nut, Jam, ¼-20, sst	Coml
11	O-Ring, Viton	2-152
12	Washer, Copper	618130105
13	Wheel Pin	L8568001
14	Retaining Clip	699992400
15	Washer, Copper, 0.212 OD x 0.137 ID x 0.025 inch thick	618130100
16	Bearing, Needle	2111997800
17	Sleeve	L6098001

- 5 Install the O-ring in its groove by laying the O-ring over the groove evenly and pressing the O-ring into the groove in two places 180° apart, then two at 90°, and continue pressing until it is completely in its groove. Check to be sure that the O-ring parting line is not rolled into the sealing area. Wipe off the excess grease with Alcohol and a lint-free wipe.

4-2-4 Valve Assembly (See Figure 1)

- 1 Insert the bonnet seal into the retainer and slide them over the carriage mechanism to the bonnet flange.
- 2 Carefully slide the mechanism assembly into the valve body with the valve body oriented as described in the Note before step 2, para. 4-2, then align the flange bolt holes.
- 3 Lubricate the bonnet flange screws with a small amount of Fel-Pro C-100 high-temperature lubricant and install the screws (17) and nuts into the flange.
- 4 Tighten the screws to 96 in-lbs.
- 5 Install the air connections.
- 6 Inspect the valve for free operation before installing it into the system.

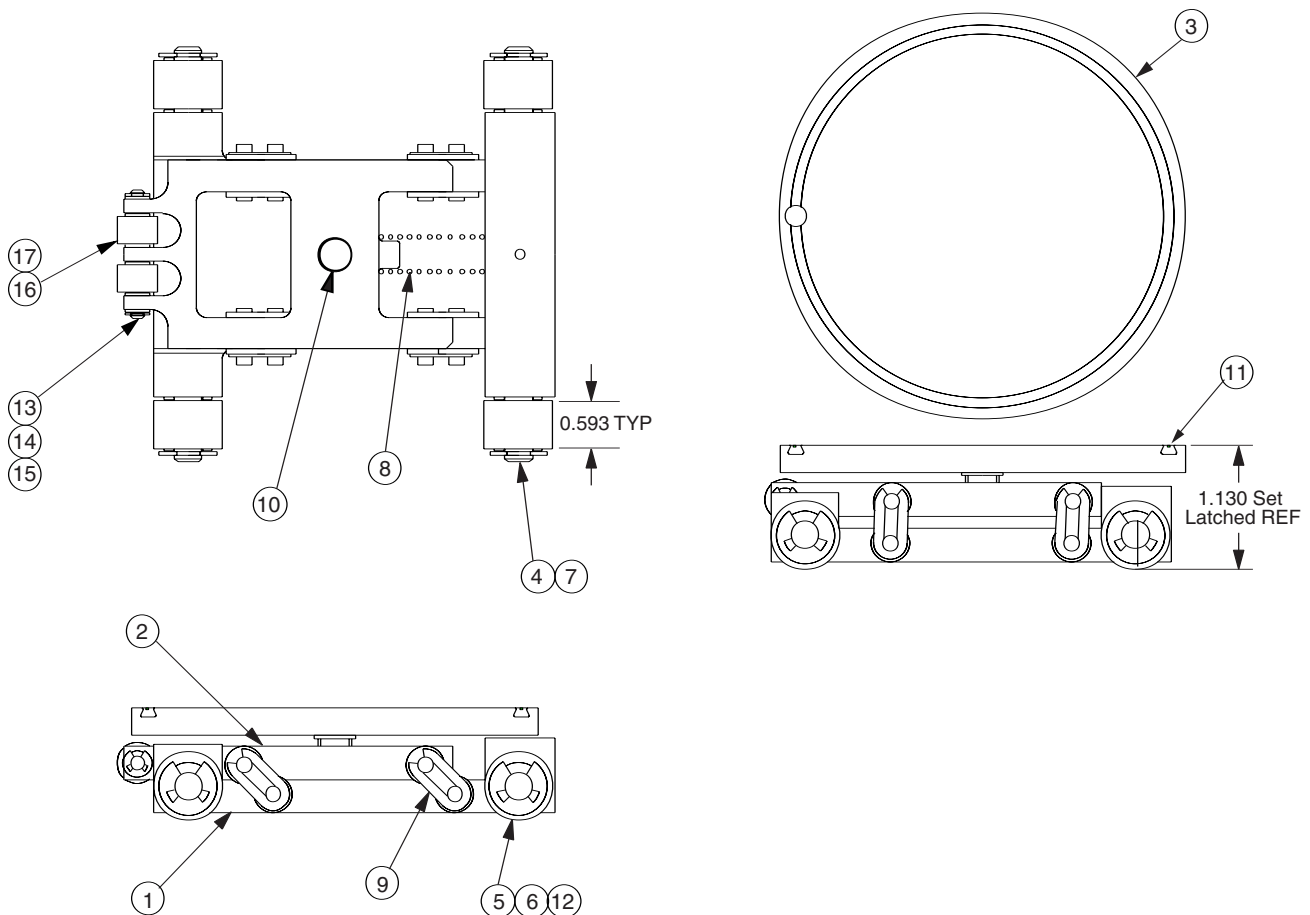

Figure 2, Sheet 1. Carriage Mechanism (2½ inch valve shown)

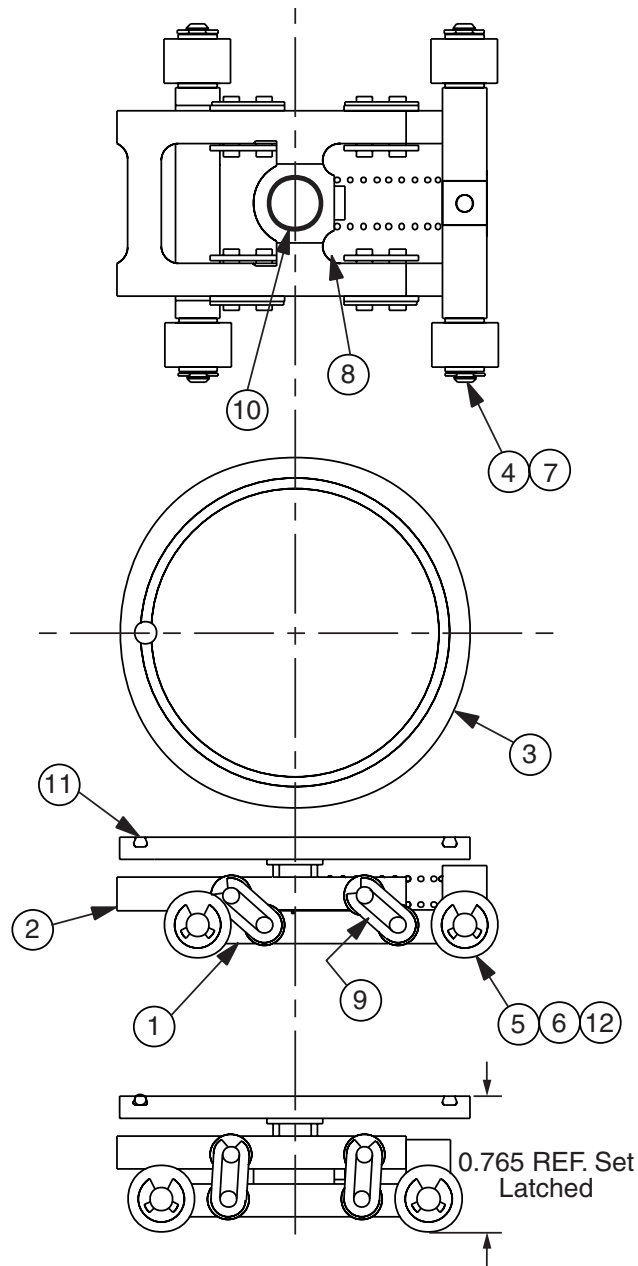

Figure 2, Sheet 2. Carriage Mechanism (1½ inch valve shown)

4-3 POSITION INDICATOR (REMOTE)

4-3-1 Disassembly - See Figure 3

- 1 Disconnect electrical power to the Position Indicator Assembly.
- 2 Remove the holding screw from the connector (4) and pull the connector off the base (7).
- 3 Remove the screw (9) from the position indicator cover (2) and lift the cover off the position indicator assembly bracket (1).
- 4 The components of the position indicator are now accessible.

4-3-2 Replacing Microswitches

- 1 Remove the mounting screws (6).
- 2 Disconnect the soldered leads from the microswitch pins and remove the microswitch.
- 3 Solder the leads to the new microswitch as outlined in Electrical Connections paragraph.
- 4 Reassemble a new switch on the bracket (1) with threaded holder (3) and spacer (19) as shown in Figure 3.
- 5 Tighten the mounting screws (6).

4-3-3 Electrical Connections for Microswitches

- 1 Before adjusting the microswitches, the valve should be either in the fully-open or fully-closed position (i.e., the valve must be closed to adjust the "closed" microswitch and open to adjust the "open" microswitch). This can be done pneumatically by pressurizing the appropriate air supply on the valve.
- 2 Loosen the mounting screws (6) of the appropriate microswitch and slide the switch along its slot until a click is heard. Tighten the screws (6), securing the switch in position. Note that the switches can be adjusted more accurately using an ohmmeter connected to the Common and N/O pins, then slide the switch until there is continuity in the circuit. Tighten the screws (6) to secure the switch in this position.

Solder the leads to the microswitches; leads are wired as shown in the following table.

Base Pin	Wire	Microswitch
1	Orange	N/O pin of "closed" switch
2	Blue	N/O pin of "open" switch
3	White	Common of either switch
Ground	Green	
	White	Common of both switches

4-3-4 Electrical Connections for Connector

- 1 Remove the holding screw from the connector (4) and pull the connector off the base.
- 2 Remove the plastic nut, washer, and seal from the housing.
- 3 Push out the beige terminal block from the holding screw side of the housing toward the square opening.
- 4 Slide the plastic nut, washer, and seal over the wires to be attached to the connector and feed the wires through the housing from the threaded side toward the square opening.
- 5 Connect the wires to the terminals on the block as shown in the following table.

Pin	Terminal Block
1	N/O pin of "closed" switch
2	N/O pin of "open" switch
3	Common
Ground	

- 6 Carefully push the terminal block back into the housing in the desired orientation until both parts snap together.

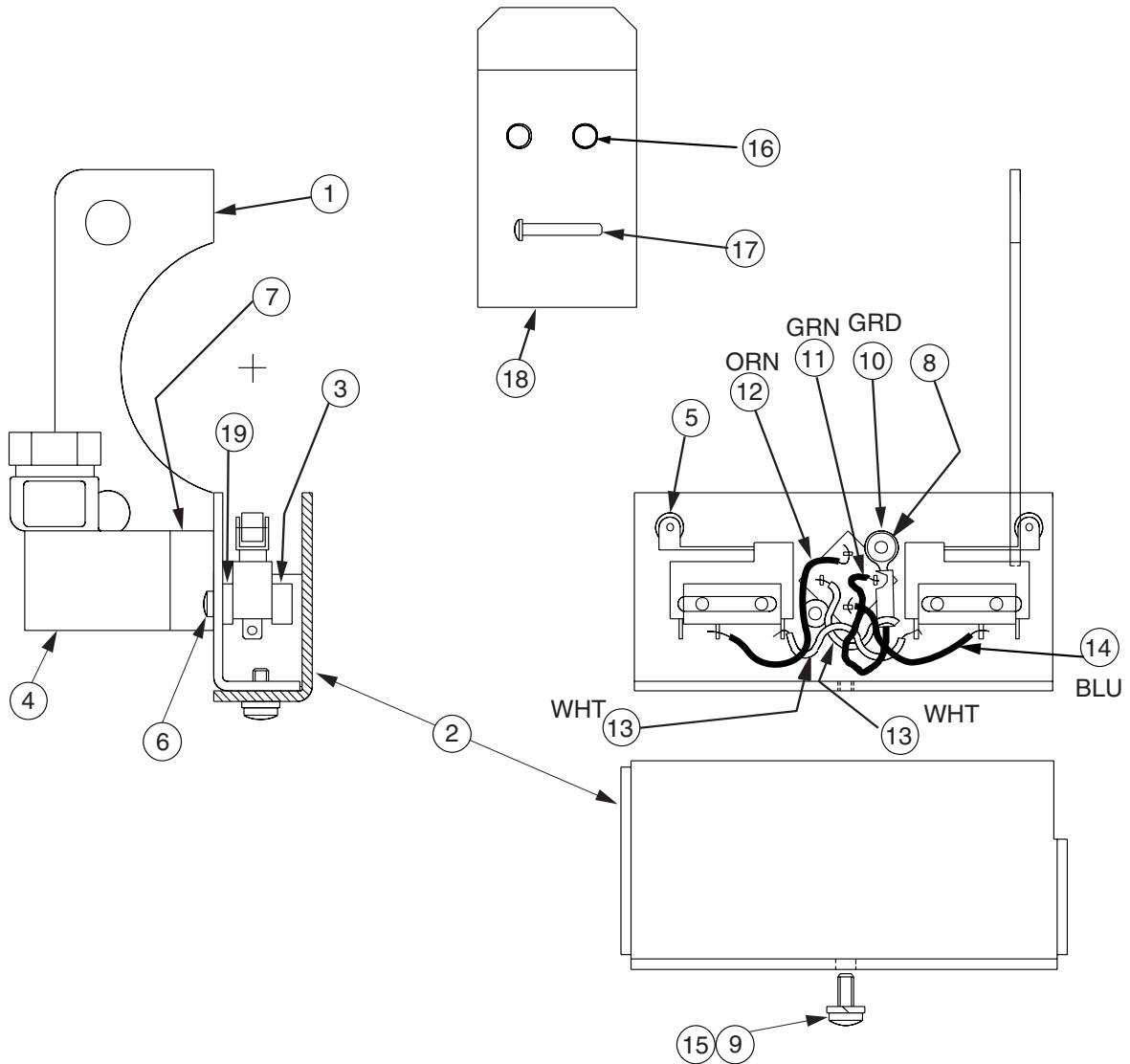

Figure 3. Typical Position Indicator Assembly

- 7 Slide the plastic nut, washer, and seal along the wires and tighten the nut in the connector. DO NOT OVERTIGHTEN.
- 8 Plug the connector (4) into the base and secure it with the holding screw.
- 9 Reconnect electrical power.

4-3-5 Reassembly

- 1 Place the position indicator cover (2) on the position indicator assembly bracket and secure it with screw (9).
- 2 Plug the connector (4) into the base and secure it with its holding screw.
- 3 Reconnect electrical power to the Position Indicator.

PARTS LIST

Carriage Assembly - 1½ Inch Linear Series Gate Valves

Item	Description	Order No.
1	Carriage, Machined	L8621001
2	Disc Mount , Machined	L8620001
3	Seal Disc	L8516301
4	Roller Pin	L8519001
5	Bearing Sleeve	L6098001
6	Bearing, Needle	2111997800
7	Retaining Clip	699992400
8	Spring, Compression, sst	660217045
10	Insert, Heli-coil no. 3585-4CN-0250	Coml
11	O-Ring, Viton, 2-030	660892030
12	Washer, Copper, 0.212 OD x 0.137 ID x 0.025 inch thick	618130100

4-3-6 Removal of Position Indicator from Valve

**CAUTION**

The position indicator must be removed from the valve any time the temperature of the valve exceeds 85°C (185°F) to prevent thermal damage to the microswitches.

- 1 Valve should be in the fully-closed position before removing the position indicator from the valve.
- 2 Disconnect electrical power to the Position Indicator.
- 3 Remove the holding screw from the connector (4) and pull the connector off the base.
- 4 Remove the two ¼ inch nuts that hold the position indicator to the valve. At the same time, prevent the long ¼ inch bolt from rotating by holding the bolt heads with an extra wrench.
- 5 Slide the position indicator from the valve.

4-3-7 Installing the Remote Position Indicator onto the Valve

- 1 The valve must be in the fully-closed position before installing the position indicator.
- 2 Disconnect both air supply lines at the actuator.
- 3 Remove the visual position indicator cap and set screw and replace them with a no. 6-32 by 1¼ inch pan head screw. Apply Loctite 222 to the threads on the end of the screw. The height of the screw should be set as shown in Figure 4. The position indicator cover (2) may be used to set the proper height of the screw by holding one of the flat sides between the bellows housing and the bottom of the screw head. Adjust the screw until it is snug against the cover, remove the cover, and back the screw out ⅓ to ½ turn. This will provide the proper screw height adjustment.

PARTS LIST

Position Indicator

Item	Description	Order No. 1½ Inch	Order No. 2½ Inch
1	Bracket Assembly	L8528301	L8615301
2	Position Indicator cover	L8529001	L8617001
3	Threaded holder	Q3033001	Q3033001
4	Connector	Coml (MPM no. 193-07N)	Coml (MPM no. 193-07N)
5	Microswitch	Coml (Cherry no. E61-10K)	Coml (Cherry no. E61-10K)
6	Screw, Pan hd	Coml (No. 2-56 x ½ lg)	Coml (No. 2-56 x ½ lg)
7	Connector base	Coml (MPM no. 193)	Coml (MPM no. 193)
8	Nut, Hex	Coml (3 mm)	Coml (3 mm)
9	Screw, Pan hd	Coml (No. 6-32 x ¾ lg)	Coml (No. 6-32 x ¾ lg)
10	Terminal	Coml (AMP no. 31881)	Coml (AMP no. 31881)
11	Wire, 20 AWG, Green	Coml, 1.75-inch lg	Coml, 1.50-inch lg
12	Wire, 20 AWG, Orange	Coml, 1.75-inch lg	Coml, 2.50-inch lg
13	Wire, 20 AWG, White	Coml, 1.75-inch lg	Coml, 2.50-inch lg
14	Wire, 20 AWG, Blue	Coml, 1.75-inch lg	Coml, 2.50-inch lg
15	Lockwasher	Coml (No. 6)	Coml (No. 6)
16	Nut, Jam	Coml (¼-20)	Coml (¼-20)
17	Screw, Phillips hd	Coml (No. 6-32 x 1 lg)	Coml (No. 6-32 x 1 lg)
19	Spacer	L8563001	L85f63001

Coml - Commercially available

- 4 Examine the position indicator assembly and note the orientation in which it will be mounted. Remove the ¼-20 nuts (14), one at a time, from the valve (see Figure 1, Sheet 1) and replace them with the jam nuts (16) provided with the position indicator assembly.
- 5 Remove the screw (9) from the position indicator cover (2) and lift the cover off the position indicator assembly bracket (1).
- 6 Install the position indicator assembly onto the valve by sliding the position indicator bracket (1) over the two long ¼-inch bolts on which the jam nuts were installed.
- 7 Secure the position indicator to the valve by installing the other two ¼-inch jam nuts (16) provided with the indicator. Tighten the two nuts (16) while preventing the bolts from rotating by holding the bolt heads with an extra wrench.
- 8 To adjust the microswitches, refer to steps 5 and 6, "Replacing and Adjusting Microswitches".
- 9 Reinstall the cover (2) and screw (9).

- 10 Plug the connector (4) into the base of the indicator and secure it with holding screw.
- 11 Reconnect electrical power.

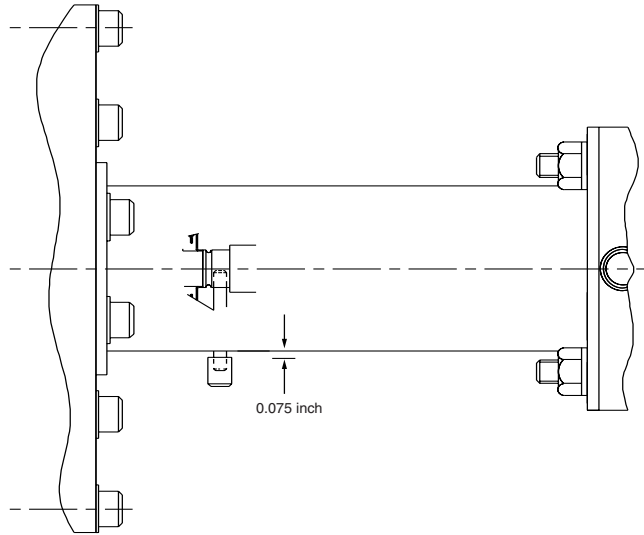

Figure 4. Set Screw Height Adjustment