

Instruction Manual



Q Series 2 Motor Control Modules - OEM

Pump/ pumping system	Electrical supply	Q Motor Control Module Item Number	
		24 V d.c. control	24 V a.c. control
QDP40	200-230 V, 3 phase, 50/60 Hz	A382-21-000	A382-22-000
QDP40	380-460 V, 3 phase, 50/60 Hz	A382-23-000	A382-24-000
QDP80	200-230 V, 3 phase, 50/60 Hz	A382-25-000	A382-26-000
QDP80	380-460 V, 3 phase, 50/60 Hz	A382-27-000	A382-28-000
QDP40/QMB250 or 500	200-230 V, 3 phase, 50/60 Hz	A382-29-000	A382-30-000
QDP40/QMB250 or 500	380-460 V, 3 phase, 50/60 Hz	A382-31-000	A382-32-000
QDP80/QMB250 or 500	200-230 V, 3 phase, 50/60 Hz	A382-33-000	A382-34-000
QDP80/QMB250 or 500	380-460 V, 3 phase, 50/60 Hz	A382-35-000	A382-36-000
QDP80/QMB1200	200-230 V, 3 phase, 50/60 Hz	A382-37-000	A382-38-000
QDP80/QMB1200	380-460 V, 3 phase, 50/60 Hz	A382-39-000	A382-40-000



CONTENTS

Section	Title	Page
1	INTRODUCTION	1
1.1	Scope and definitions	1
1.2	Description	1
1.3	Emergency off control	2
1.4	Overload protection	2
1.5	Over-temperature protection	2
1.6	Over-pressure protection	4
1.7	Nitrogen flow control and monitoring	4
1.8	Internal reset buttons	4
1.9	Control input and status output signals	4
1.10	Mounting	5
2	TECHNICAL DATA	6
2.1	Operating and storage conditions	6
2.2	Mechanical data	6
2.3	Outputs	6
2.4	Circuit breaker ratings	6
3	INSTALLATION	8
3.1	Safety	8
3.2	Unpack and inspect	8
3.3	Check that the Motor Control Module is suitable for your electrical supply	9
3.4	Fit the Motor Control Module	9
3.4.1	Pumping system without an Acoustic Enclosure	9
3.4.2	Pumping system with an Acoustic Enclosure	9
3.5	Electrical connections	11
3.5.1	Introduction	11
3.5.2	Connect the Motor Control Module to the QDP pump	11
3.5.3	Connect the Motor Control Module to the QMB pump (QDP/QMB Motor Control Modules only)	14
3.5.4	Connect to your control equipment	14
3.5.5	Connect the Motor Control Module to the electrical supply	16
3.6	Check the direction of pump rotation	16
3.6.1	QDP Motor Control Modules	16
3.6.2	QDP/QMB Motor Control Modules	17
4	OPERATION	18
4.1	Introduction	18
4.2	Normal start-up	18
4.3	Fault conditions	18
4.4	Restart after fault or emergency off	19
4.4.1	Restart after over-temperature	19
4.4.2	Restart after exhaust pressure fault	19
4.4.3	Restart after circuit breaker trip	20

Section	Title	Page
4.4.4	Restart after emergency off	21
4.4.5	Restart procedure	21
4.5	Normal shut-down	21
4.6	Emergency shut-down	21
5	MAINTENANCE	22
5.1	Introduction	22
5.2	Fault finding	22
6	STORAGE AND DISPOSAL	23
6.1	Storage	23
6.2	Disposal	23
7	ENGINEERING DIAGRAMS	23
	RETURN OF BOC EDWARDS EQUIPMENT	

Illustrations

Figure	Title	Page
1	Front panel of the Motor Control Module	3
2	Dimensions (mm)	7
3	Fit the Motor Control Module	10
4	Interior layout of the Motor Control Module (QDP/QMB Motor Control Module shown)	13
5	Circuit diagram for the QDP Motor Control Module	24
6	Circuit diagram for the QDP/QMB Motor Control Module	27

Tables

Table	Title	Page
1	Checklist of items	8
2	17-way connector signals (QDP pump auxiliary cable: 12-core)	12
3	19-way connector signals (gas module cable: 8-core)	12
4	Communication connector signals	15
5	Emergency off connector signals	15
6	Fault finding	22

1 INTRODUCTION

1.1 Scope and definitions

This manual provides installation, operation and maintenance instructions for the BOC Edwards Q Series 2 Motor Control Modules - OEM, abbreviated to Motor Control Module in the rest of this manual. You must use the Motor Control Modules as specified in this manual.

Read this manual before you install and operate the Motor Control Module. Important safety information is highlighted as WARNING and CAUTION instructions; you must obey these instructions. The use of WARNINGS and CAUTIONS is defined below.

WARNING

Warnings are given where failure to observe the instruction could result in injury or death to people.

CAUTION

Cautions are given where failure to observe the instruction could result in damage to the equipment, associated equipment and process.

The units used throughout this manual conform to the SI international system of units of measurement.

1.2 Description

The Motor Control Module is used to control the operation of a pumping system which has a QDP dry pump, or a combination pumping system which has a QDP dry pump and a QMB mechanical booster pump. The Motor Control Module is designed to be remotely operated; to control the operation of the pumping system, you must connect your own control equipment to the Motor Control Module through connectors (see Section 1.9). The front panel of the Motor Control Module has no controls except for the Emergency Off button.

Two types of Motor Control Modules are available:

- QDP Motor Control Modules for use with QDP pumping systems.
- QDP/QMB Motor Control Modules for use with QDP/QMB combination pumping systems.

The Motor Control Modules have protection devices to switch off the pump(s) if a pump or pump-motor overheats or if an over-current condition is detected.

The QDP/QMB Motor Control Module has interlocks which ensure that the QMB pump is only switched on when the QDP pump is switched on.

1.3 Emergency off control

Refer to Figure 1. The front panel of the Motor Control Module has an Emergency Off button (10). Press this button to switch off the pump(s) in an emergency. You must reset the Emergency Off button before you can restart the pumping system (see Section 3).

1.4 Overload protection

All Motor Control Modules have a thermal magnetic circuit breaker CB1 which protects the QDP pump-motor from an over-current condition. The QDP/QMB Motor Control Modules also have a thermal magnetic circuit breaker CB2 which protects the QMB pump-motor from an over-current condition. If a pump-motor overloads, the Motor Control Module switches off the pump. The QDP/QMB Motor Control Module will switch off both pumps if the QDP pump-motor overloads.

Circuit breakers CB3 and CB4 protect the transformer primary and circuit breaker CB5 protects the 24 V a.c. control circuit in the Control Module.

Circuit breaker CB6 protects the electrical supply which is used to actuate the nitrogen supply solenoid-valve (see Section 1.7).

If any of circuit breakers CB1 to CB5 trip, the Motor Control Module switches off the pump(s).

1.5 Over-temperature protection

Thermistors in the QDP and QMB pump-motors monitor the temperature of the motors. The outputs of these thermistors are monitored by the Motor Control Module. If a pump-motor is too hot (that is, if the temperature of the pump-motor is higher than 160 °C), the Motor Control Module switches off the pump. On the QDP/QMB Motor Control Module, if the QDP pump is switched off because its pump-motor is too hot, the QMB pump will also be switched off. The pump(s) can only be switched on again if the temperature of the pump-motor has fallen to below 160 °C.

There are two thermal snap-switches on the QDP pump. The warning thermal snap-switch opens to indicate that the pump temperature is higher than the normal operating temperature. The shut-down thermal snap-switch opens to indicate that the pump temperature is 95 °C or higher. The status of these two QDP pump snap-switches are monitored by the Motor Control Module and are also included in grouped warning and grouped hazard output status signals from the Motor Control Module. When the shut-down thermal snap-switch opens (that is, when the QDP pump temperature is 95 °C or higher), the Motor Control Module will switch off the QDP pump. On the QDP/QMB Motor Control Module, if the QDP pump is switched off because the shut-down thermal snap-switch has opened, the QMB pump is also switched off.

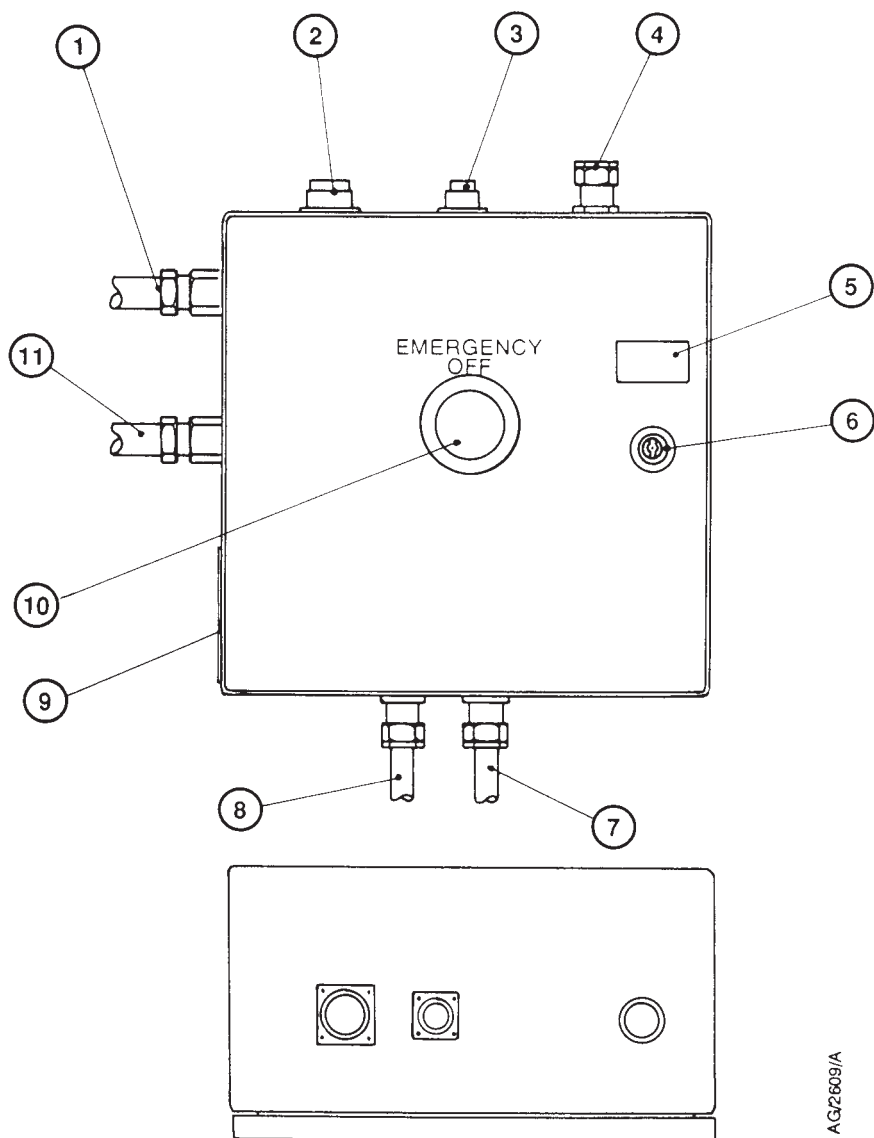

AG2609/A

- | | |
|----------------------------------|--|
| 1. Gas Module cable | 7. QMB pump electrical supply cable
(QDP/QMB Motor Control Module only) |
| 2. Communication connector | 8. QDP pump electrical supply cable |
| 3. Emergency off connector | 9. Rating label |
| 4. Electrical supply cable gland | 10. Emergency Off button |
| 5. Warning label | 11. QDP pump auxiliary cable |
| 6. Lock | |

Figure 1 - Front panel of the Motor Control Module

1.6 Over-pressure protection

The Motor Control Module can monitor two pressure-switches (such as those in a QDP Exhaust Pressure Module) which operate at preset pressures to provide warning and shut-down pressure indications. The status of the pressure-switches are also included in grouped warning and grouped hazard output status signals from the Motor Control Module.

If the shut-down pressure is reached (for example, if the Exhaust Pressure Module shut-down pressure-switch opens to indicate that the QDP pump exhaust pressure is 6 psig or higher), the Motor Control Module automatically switches off the QDP pump. On the QDP/QMB Motor Control Module, if the QDP pump is switched off because the shut-down pressure-switch has opened, the QMB pump is also switched off.

1.7 Nitrogen flow control and monitoring

The Motor Control Module is designed to be used with a pumping system fitted with a QDP Gas Module and the Motor Control Module will actuate the nitrogen supply solenoid-valve in the QDP Gas Module to control the supply of nitrogen to the QDP pump. The electrical supply to the solenoid-valve will be switched on when the QDP pump is switched on and the electrical supply will be switched off when the QDP pump is switched off.

If you have a nitrogen flow-switch on your pumping system, the outputs of the flow-switch are connected to the Motor Control Module. The flow-switch opens to indicate a low flow of nitrogen. A low nitrogen flow indication is available as a status signal from the Motor Control Module at the communication connector.

1.8 Internal reset buttons

The Motor Control Module has circuit breaker reset buttons and a thermistor control relay reset button. If the pumping system has been automatically shut-down because one of the circuit breakers has tripped or because one of the pump-motors is too hot, you must operate the necessary reset button before you can restart the pumping system. Refer to Section 4.4.

To access the reset buttons, unlock and open the door of the Motor Control Module. You must use a non-conducting probe or an insulated screwdriver to operate the reset buttons: refer to Section 4.4.

1.9 Control input and status output signals

The Motor Control Module has a 16-pin communication connector (Figure 1, item 2) and a 4-pin emergency off connector (Figure 1, item 3):

- Control input signals on the communication connector are used to switch the pumping system on and off.
- Status signals output on the two connectors can be used by your own control equipment.

Tables 4 and 5 show the use of the pins in the connectors: refer to Section 3.5.4.

1.10 Mounting

The Motor Control Module is only suitable for mounting on the frame of the pumping system; that is, on the QDP pump frame or on the QMB booster frame of a QDP/QMB combination pumping system (with or without an Acoustic Enclosure).

If you want to mount the Motor Control Module in another position, contact your supplier or BOC Edwards for advice.

2 TECHNICAL DATA

2.1 Operating and storage conditions

Operating ambient temperature range	5 to 40 °C
Maximum operating ambient humidity	90% RH
Storage ambient temperature range	-30 to 50 °C
Maximum storage ambient humidity	97% RH

2.2 Mechanical data

Mass	
QDP Motor Control Module	12.5 kg
QDP/QMB Motor Control Module	13 kg
Dimensions	See Figure 2

2.3 Outputs

QDP40 dry pump	2.2 kW
QDP80 dry pump	4 kW
QMB250 or QMB500 mechanical booster pump*	2.2 kW
QMB1200 mechanical booster pump*	4 kW

2.4 Circuit breaker ratings

CB3 (transformer primary)	300 mA
CB4 (transformer primary)	300 mA
CB5 (24 V a.c. control circuit)	2 A
CB6 (nitrogen supply solenoid-valve electrical supply)	1 A

* QDP/QMB Motor Control Modules only

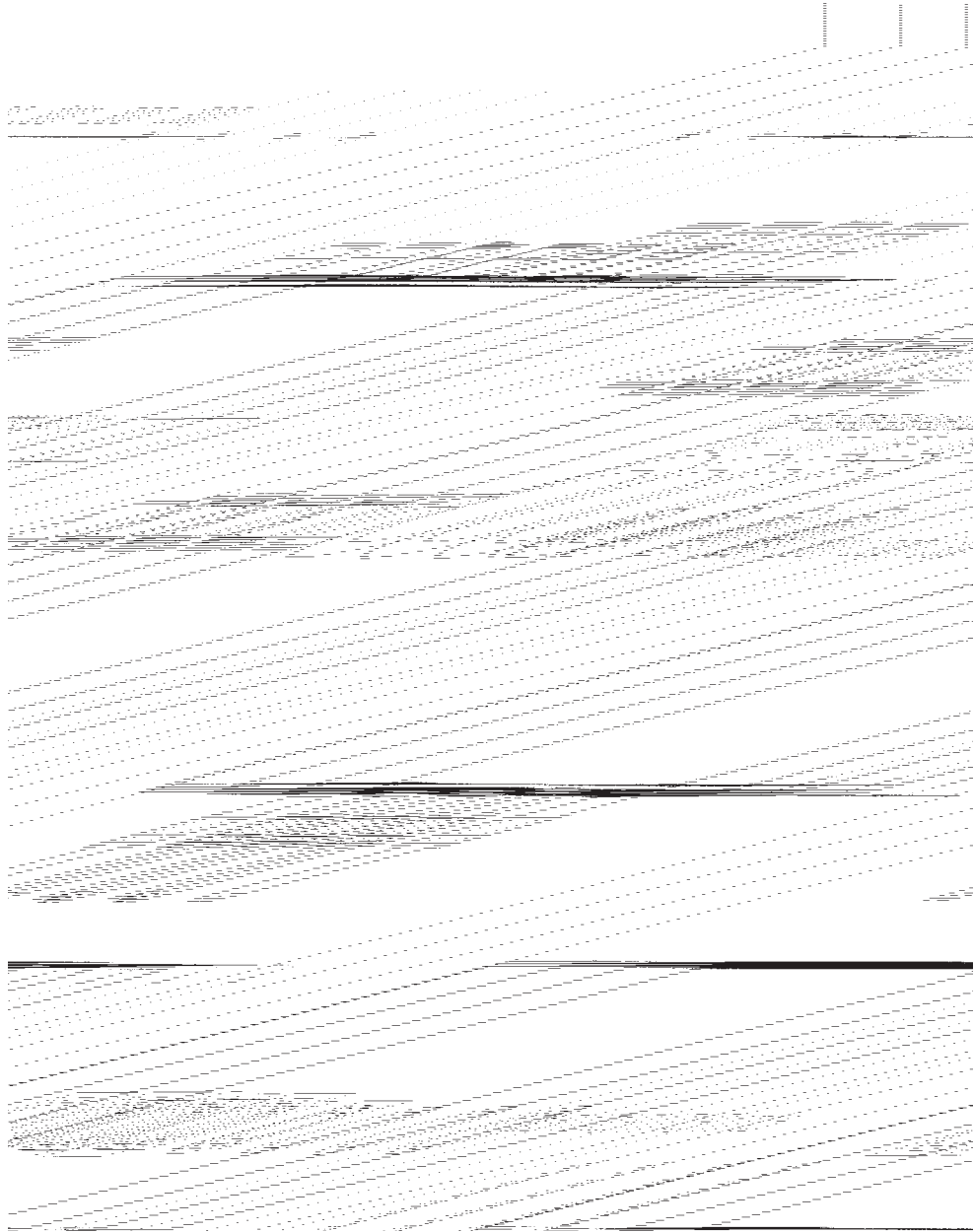

Figure 2 - Dimensions (mm)

3 INSTALLATION

3.1 Safety

WARNING

Obey the safety instructions given below and take note of appropriate precautions. If you do not, you can cause injury to people and damage to equipment.

- A suitably trained and supervised technician must install the Motor Control Module.
- If you install the Motor Control Module on pump(s) in an existing pumping system, switch off the pump(s) and allow them to cool to a safe temperature before you start installation.
- Disconnect the other components in the pumping system from the electrical supply so that they cannot be operated accidentally.
- If you disconnect or connect any vacuum connections during installation, you must leak-test the pumping system after installation is complete.

3.2 Unpack and inspect

Remove all packing materials and protective covers and check the Motor Control Module. If the Motor Control Module is damaged, notify your supplier and the carrier in writing within three days; state the Item Number of the Motor Control Module together with your order number and your supplier's invoice number. Retain all packing materials for inspection. Do not use the Motor Control Module if it is damaged.

Check that you have received the items listed in Table 1. If any item is missing, notify your carrier in writing within three days.

If the Motor Control Module is not to be used immediately, replace the protective covers and store the Motor Control Module in suitable conditions, as described in Section 6.

Qty	Description	Check (✓)
1	Motor Control Module (with integral cables)	<input type="checkbox"/>
2	Mounting brackets	<input type="checkbox"/>
4	M8 nuts, bolts and lock washers	<input type="checkbox"/>
8	M8 plain washers	<input type="checkbox"/>
4	M5 bolts and washers	<input type="checkbox"/>
1	16-way communication connector	<input type="checkbox"/>
20	Female sockets	<input type="checkbox"/>
1	Strain-relief clamp	<input type="checkbox"/>
1	4-way emergency off connector	<input type="checkbox"/>
2	Cable clamp	<input type="checkbox"/>

Table 1 - Checklist of items

3.3 Check that the Motor Control Module is suitable for your electrical supply

Before you start installation work, check that the electrical supply voltage shown on the rating label (Figure 1, item 9) on the Motor Control Module is correct for your electrical supply.

Do not install and operate the Motor Control Module if it is not suitable for your electrical supply.

3.4 Fit the Motor Control Module

3.4.1 Pumping system without an Acoustic Enclosure

Use the following procedure to fit the Motor Control Module onto the QDP pump frame or the QMB Booster Frame. Refer to Figure 3.

1. Unlock and open the door (1) of the Motor Control Module, then use the four M8 nuts, washers and bolts (3, 4, 7) supplied with the Motor Control Module to fix the two mounting brackets (5) to the Motor Control Module (2).
2. Use the four M5 bolts (6) supplied to secure the mounting brackets (5) to the pumping system frame (9).

3.4.2 Pumping system with an Acoustic Enclosure

Use the following procedure to fit the Motor Control Module onto the QDP pump frame or the QMB booster frame. Refer to Figure 3. Where necessary, refer to the instruction manual supplied with your pumping system, QMB Booster Frame and Acoustic Enclosure.

1. Remove the four M5 bolts (6) which secure the top-front panel (8) to the pumping system frame (9), then remove the panel.
2. If you have a QDP pumping system, remove the blanking grommet from the cable leadthrough hole nearest to the centre of the top-front panel. If you have a QDP/QMB combination pumping system, remove the blanking plate over the single cable leadthrough hole.
3. Unlock and open the door (1) of the Motor Control Module, then use the four M8 nuts, washers and bolts (3, 4, 7) supplied with the Motor Control Module to fix the two mounting brackets (5) to the Motor Control Module (2).
4. Place the top-front panel (8) back in position on the pumping system frame (9).
5. Feed the pump electrical supply cable(s) through the leadthrough hole in the top-front panel (8), then place the Motor Control Module (with the mounting brackets) in position on the top-front panel.
6. Use the four M5 bolts (6) removed in Step 1 to secure the mounting brackets (5) and top-front panel (8) to the pumping system frame (9).

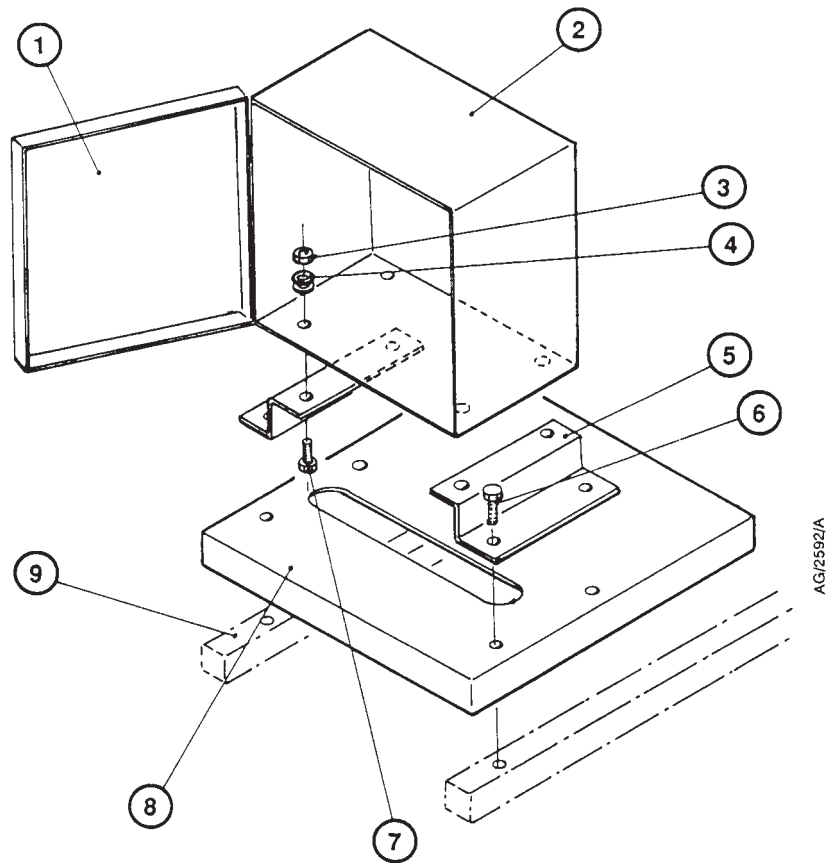

- | | |
|------------------------------------|--------------------------------|
| 1. Door (shown open) | 6. M5 bolt |
| 2. Motor Control Module | 7. M8 bolt |
| 3. M8 nut | 8. Top-front panel (if fitted) |
| 4. M8 lock washer and plain washer | 9. Pumping system frame |
| 5. Mounting bracket | |

Figure 3 - Fit the Motor Control Module

3.5 Electrical connections

3.5.1 Introduction

The procedures to make the electrical connections between the Motor Control Module, the incoming electrical supply and the QDP and QMB pumps are described in the following sections. Refer to Figure 4 for the internal layout of the Control Module and to Figures 5 and 6 for the circuit diagrams.

3.5.2 Connect the Motor Control Module to the QDP pump

Note: If you do not have a QDP Gas Module fitted to your pump, or if you have a QDP Gas Module fitted but do not have a QDP Exhaust Pressure Module fitted, you must fit the links as described below. If you do not, you will not be able to start your pumping system.

Refer to Figure 1 and use the following procedure to connect the Motor Control Module to the QDP pump. Cables to connect the Motor Control Module to the QDP pump are supplied fitted to the Motor Control Module. Where necessary, refer to the instruction manual supplied with your QDP pump and QDP Gas Module (if fitted).

1. Connect the wires at the end of the QDP pump electrical supply cable (8) to the QDP pump motor as described in the instruction manual supplied with the QDP pump.
2. Fit the 17-way connector on the end of the QDP pump auxiliary cable (11) to the 17-way connector on the QDP pump services panel; the use of the sockets in the connector are shown in Table 2.
3. If you have a QDP Gas Module fitted to your pump, fit the 19-way connector on the end of the Gas Module cable (1) to the 19-way connector on the front of the QDP Gas Module; the use of the sockets in the connector are shown in Table 3.
4. If you do not have a QDP Gas Module fitted to your pump, or if you have a QDP Gas Module but do not have a QDP Exhaust Pressure Module fitted:
 - Fit a link between terminals 37 and 16 in the Motor Control Module (Figure 4, detail A)
 - Fit a link between terminals 16 and 40 in the Motor Control Module (Figure 4, detail A)
 - If required, disconnect the wires in the gas module cable from the terminals in the Motor Control Module, remove the gas module cable and use a suitable blank gland to seal the cable leadthrough hole in the Motor Control Module.

Terminal		17-way connector terminal	Wire	Signal
QDP Motor Control Module	QDP/QMB Motor Control Module			
24	24	T	1	QDP thermistors
25	23	S	2	
-	26	R	3	QMB thermistors
-	25	P	10	
34	34	K	4	Nitrogen flow-switch
16	16	J	5	
36	36	H	6	Shut-down thermal snap-switch
38	38	G	7	
42	42	F	8	Warning thermal snap-switch
41	41	E	9	
Earth block	Earth block	C	- (Green/ yellow)	Earth (ground)

Table 2 - 17-way connector signals (QDP pump auxiliary cable: 12-core)

QDP/QMB Motor Control Module terminal	19-way connector terminal	Wire	Signal
40	E	1	Warning pressure-switch: normally closed
16	H	2	
16	G	3	Shut-down pressure-switch: normally closed
37	C	4	
15	V	5	Nitrogen supply solenoid-valve
32	U	6	

Table 3 - 19-way connector signals (gas module cable: 8-core)

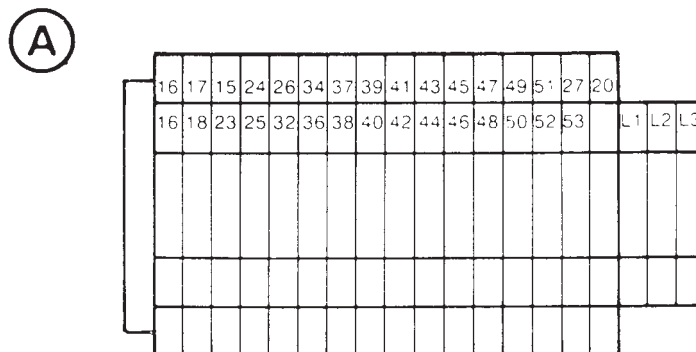
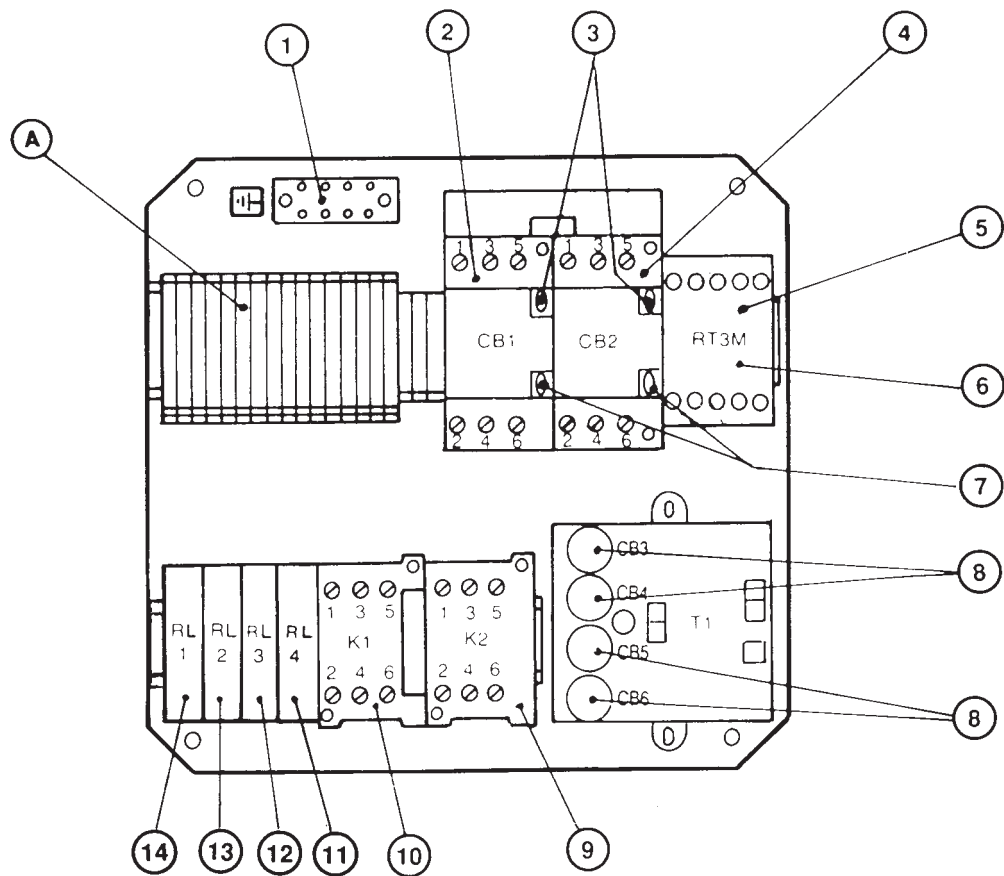

A.G.2610/A

A Terminal block

- | | |
|--|---|
| 1. Earth terminal block | 8. Circuit breaker reset buttons (CB3, CB4, CB5, CB6) |
| 2. Circuit breaker CB1 (QDP pump) | 9. QMB pump contactor (K2) |
| 3. CB1 and CB2 trip buttons (red) | 10. QDP pump contactor (K1) |
| 4. Circuit breaker CB2 (QMB pump) | 11. Warning signals relay (RL4) |
| 5. Thermistor control relay | 12. Pumping system on/off relay (RL3) |
| 6. Thermistor control relay reset button | 13. Hazard signals relay (RL2) |
| 7. CB1 and CB2 reset buttons (green) | 14. Nitrogen flow relay (RL1) |

Figure 4 - Interior layout of the Motor Control Module
(QDP/QMB Motor Control Module shown)

3.5.3 Connect the Motor Control Module to the QMB pump (QDP/QMB Motor Control Modules only)

A 1.5 m long cable to connect the Motor Control Module to the QMB pump is supplied fitted to the Motor Control Module.

Refer to Figure 1 and to the instruction manual supplied with your QMB pump. Connect the wires at the end of the QMB pump electrical supply cable (7) to the QMB pump motor as described in the instruction manual supplied with the QMB pump.

3.5.4 Connect to your control equipment

If you do not have a nitrogen flow-switch fitted, you must fit a link between terminals 32 and 34 on the terminal block in the Motor Control Module (see Figure 4) and you must remove the three-pin flow-switch electrical connector (which connects pins J and K) from the rear of the 17-way connector on the QDP pump (refer to the QDP instruction manual), as:

- If you do not fit the link, the low nitrogen flow status contacts on pins 11 and 12 of the communication connector will be permanently open circuit.
- If you fit the link, but do not remove the electrical connector, you will not be able to stop your pumping system.

Connector mating halves for the communication and emergency off connectors (Figure 1, items 2 and 3) are supplied; you must fit suitable cables to these connector mating halves to connect the Motor Control Module to your control equipment. Use the pins in the emergency off and communication connectors as described in Tables 4 and 5.

1. Use the strain relief clamp and female sockets and fit a suitable cable from your control equipment to the 16-pin female connector supplied.
2. Fit the connector to the communication connector (Figure 1, item 2) on the Motor Control Module.

If you will use the emergency off output from the Motor Control Module in your control equipment:

1. Use the cable clamp and fit a suitable cable from your control equipment to the 4-pin female connector supplied.
2. Fit the connector to the emergency off connector (Figure 1, item 3) on the Motor Control Module.

Pin	Function	Type	Use
1 and 2	Pumping system start/stop	Control input	0 or 24 V a.c. or d.c. (according to model of Motor Control Module): Set to 24 V to start the pumping system, set to 0 V to stop the pumping system.
3 and 4	Pumping system operating	Status output	Volt-free contacts: closed when the pumping system is operating.
5 and 6	Alternative pumping system start/stop VFC control	Control input	Volt-free contacts: close to start the pumping system, open to stop the pumping system.
7 and 8	Warning status	Status output	Volt-free contacts: open when the warning pressure-switch has operated or the warning thermal snap-switch has operated.
9 and 10	Hazard status	Status output	Volt-free contacts: open when the shut-down pressure-switch has operated or the shut-down thermal snap-switch has operated.
11 and 12	Low nitrogen flow status	Status output	Volt-free contacts: open when the nitrogen flow-switch has operated.
13 to 16	Not used	-	-

Table 4 - Communication connector signals

Pin	Function	Type	Use
1 and 2	Emergency off	Status output	Volt-free contacts: open when the Emergency Off button has been pressed
3 and 4	Not used	-	-

Table 5 - Emergency off connector signals

3.5.5 Connect the Motor Control Module to the electrical supply

WARNING

Use a suitably rated and fused isolator and cable to connect the Motor Control Module to the electrical supply.

A cable to connect the Motor Control Module to your electrical supply is **not** supplied. You must supply your own suitably rated cable.

1. Refer to Figure 1. Undo the lock (6) and open the door of the Motor Control Module.
2. Use a suitable fused isolator to connect a suitable 4-core armoured cable to your electrical supply. Do not turn on your electrical supply yet.
3. Pass the electrical supply cable through the cable gland (4) on the Motor Control Module.
4. Refer to Figure 4. Connect the three phase wires to terminals L1, L2 and L3 on the terminal block (detail A). Connect the earth wire to a free terminal on the earth terminal block (1).
5. Ensure that all of the circuit breakers are reset; that is:
 - The red (trip) buttons on CB1 and CB2 (3) are pressed in and the green (reset) buttons (7) are out.
 - The thermistor control relay reset button (6) is pressed in.
 - Circuit breaker reset buttons CB3 to CB6 (8) are pressed in.
6. Close and lock the door of the Motor Control Module.

3.6 Check the direction of pump rotation

3.6.1 QDP Motor Control Modules

Check the direction of rotation of the QDP pump as described below before you connect your pump to your vacuum system and to your exhaust-extraction system. Refer to Figure 1 and where necessary to the instruction manual supplied with your QDP pump.

1. Switch on the electrical supply isolator.
2. Check the direction of rotation of the QDP pump as described in the instruction manual supplied with the pump: use the pumping system start/stop control input signal at the communication connector to start and stop the pump.
3. If the direction of rotation is incorrect:
 - Switch off the electrical supply isolator.
 - Swap any two of the phase connections in the QDP pump-motor terminal-box: refer to the instruction manual supplied with the QDP pump.
 - Switch on the electrical supply isolator, then repeat Steps 1 and 2 to make sure that the QDP pump now rotates in the correct direction.

3.6.2 QDP/QMB Motor Control Modules

CAUTION

If your QDP pump is connected to the QMB pump by a flexible pipeline (for example, by bellows), loosen the connections before you check the direction of rotation of the pumps.
If you do not, you may damage the pipeline.

Use the following procedure to check the direction of rotation of the QDP and QMB pumps before you operate your pumping system. We recommend that you use this procedure before you connect the QMB pump to the QDP pump and before you connect your pumping system to the vacuum system and to your exhaust-extraction system.

1. If your QDP pump is already connected to your QMB pump by a flexible vacuum pipeline, loosen the flange bolts to prevent damage to the pipeline.
2. Check the direction of rotation of the QDP pump as described in Section 3.6.1, Steps 1 to 3.
3. Check the direction of rotation of the QMB pump as described in the instruction manual supplied with the pump; use the pumping system start/stop control input signal at the communication connector to start and stop the pumps.
4. If the direction of rotation is incorrect:
 - Switch off the electrical supply isolator and swap any two of the phase connections in the QMB pump-motor terminal-box: refer to the instruction manual supplied with the QMB pump.
 - Switch on the electrical supply isolator, then repeat Step 3 to make sure that the QMB pump now rotates in the correct direction.
5. If your pumps are connected by a flexible pipeline, tighten the flange bolts then leak-test the installation as described in the instruction manual(s) supplied with your pump or pumping system.

4 OPERATION

4.1 Introduction

Use the Motor Control Module to operate the pumping system as described in the following sections.

The following sections assume that the Motor Control Module has been correctly installed and that the pumps and any accessories have been installed in accordance with their own instruction manuals.

Note that there are two control input signals you can use to operate the pumping system: the start/stop control input signal on pins 1 and 2 of the communication connector and the start/stop VFC control input signal on pins 5 and 6 of the communication connector. When you use one of these control input signals to start the pumping system, you must use the same control input signal to stop the pumping system.

4.2 Normal start-up

1. Switch on the electrical supply isolator.
2. Switch on the pumping system; use one of the following methods:
 - Set the pumping system start/stop control input signal on pins 1 and 2 of the communication connector: set pin 1 to 24 V, set pin 2 to return.
 - Close the start/stop VFC control signal on pins 5 and 6 of the communication connector.

When the pumping system is on, the pumping system operating status contacts on pins 3 and 4 of the communication connector will go closed circuit.

4.3 Fault conditions

If you have a nitrogen flow-switch in your pumping system, the low nitrogen flow status contacts on pins 11 and 12 of the communication connector will go open circuit to indicate that the flow of nitrogen to the pump is low.

If you do not have a nitrogen flow-switch in your pumping system and have not fitted the link as described in Section 3.5.4, the low nitrogen flow status contacts on pins 11 and 12 of the communication connector will be open circuit.

Fault conditions which do not automatically shut down the pumping system will cause the warning status contacts on pins 7 and 8 of the communications connector to go open circuit (see Table 4). If the warning status contacts go open circuit, you must shut down the pumping system as soon as possible and identify the cause of the warning.

You must identify the cause of any fault and rectify the fault before you restart the pumping system.

4.4 Restart after fault or emergency off

4.4.1 Restart after over-temperature

WARNING

Switch off the electrical supply to the Motor Control Module and use an insulated probe or a non-conducting screwdriver to operate the thermistor control relay reset button. There are live components in the Motor Control Module if the electrical supply is on.

If the pumping system has shut-down because the shut-down thermal snap-switch indicates that the QDP pump is too hot , the pumping system cannot be restarted until the pump has cooled down. Allow the pump to cool down, make sure that an adequate supply of cooling-water is available, then restart the pumping system as described in Section 4.4.5.

If the pumping system has shut-down because the motor protection thermistors indicate that one of the pump-motors is too hot , the pumping system cannot be restarted until the pump-motor has cooled down and the thermistor control relay has been reset. Allow the pump-motor to cool down, make sure that an adequate supply of cooling-water is available, then use the following procedure to restart the pumping system:

1. Switch off the electrical supply.
2. Unlock and open the door of the Motor Control Module.
3. Refer to Figure 4. Press the thermistor control relay reset button (6).
4. Close and lock the door of the Motor Control Module.
5. Switch on the electrical supply.
6. Restart the pumping system as described in Section 4.4.5.

4.4.2 Restart after exhaust pressure fault

If the pumping system has automatically shut down because of over-pressure (that is, the QDP shut-down pressure has been reached), the exhaust pressure must fall below the operating pressure level of the pressure-switch before you can restart the system.

If the shut-down pressure-switch operates again when the pumping system is restarted, shut the system down and check that the QDP exhaust silencer and your exhaust-extraction system are not blocked.

4.4.3 Restart after circuit breaker trip

WARNING

Switch off the electrical supply to the Motor Control Module and use an insulated probe or a non-conducting screwdriver to operate the circuit breaker reset buttons. There are live components in the Motor Control Module if the electrical supply is on.

If the pumping system has shut down because of an electrical overload (that is, any of the circuit breakers have tripped), you must reset the circuit breaker before you can restart the pumping system.

To reset circuit breaker CB1 or CB2:

1. Switch off the electrical supply.
2. Unlock and open the door of the Motor Control Module.
3. Refer to Figure 4. Press the appropriate trip (red) button (3), then press the appropriate reset (green) button (7).
4. Close and lock the door of the Motor Control Module.
5. Switch on the electrical supply.
6. Restart the pumping system as described in Section 4.4.5.

To reset one of circuit breakers CB3 to CB6:

1. Switch off the electrical supply
2. Unlock and open the door of the Motor Control Module.
3. Push in the appropriate circuit breaker reset button (8).
4. Close and lock the door of the Motor Control Module.
5. Switch on the electrical supply.
6. Restart the pumping system as described in Section 4.4.5.

4.4.4 Restart after emergency off

WARNING

The pumping system will automatically restart if the control input signal that you used to start the pumping system is still set to start when you reset the Emergency Off button.

If you have used the Emergency Off button (Figure 1, item 10) to shut down the pumping system, you must reset the button before you can restart the system. Twist the button to reset it, then restart the pumping system as described in Section 4.4.5.

4.4.5 Restart procedure

After the fault condition has been corrected or the Emergency Off button has been reset, restart the pumping system; use one of the following methods:

- Set the pumping system start/stop control input signal on pins 1 and 2 of the communication connector: set pin 1 to 24 V, set pin 2 to return.
- Close the start/stop VFC control input signal on pins 5 and 6 of the communication connector.

If the same fault condition arises again, switch off immediately and identify and rectify the fault.

4.5 Normal shut-down

To shut down the pumping system, you must use the correct control input signal (the signal that you used to start the pumping system); that is, use one of the following methods:

- Reset the start/stop control input signal on pins 1 and 2 of the communication connector: remove 24 V from pin 1.
- Open the start/stop VFC control input signal on pins 5 and 6 of the communication connector.

When the pumping system is off, the pumping system operating status contacts on pins 3 and 4 of the communication connector will go open circuit.

4.6 Emergency shut-down

To shut down the pumping system in an emergency, press the Emergency Off button (Figure 1, item 10).

5 MAINTENANCE

WARNING

Switch off the electrical supply to the Motor Control Module before you do fault finding or reset the circuit breakers or thermistor control relay. There are live components in the Motor Control Module if the electrical supply is on.

5.1 Introduction

Check the following items when you maintain your pumping system:

- Check that the Motor Control Module is securely fitted
- Check that all electrical connections are secure and that electrical cables are not damaged.

The Motor Control Module contains no parts which can be serviced by the user. Repair of faults by the user is limited to the resetting of circuit breakers (see Section 4). If any other repairs are required, contact your supplier or your nearest BOC Edwards Service Centre for advice.

5.2 Fault finding

If you suspect a fault in your Motor Control Module, check the possible causes and correct any fault as described in Table 6 before you return the Motor Control Module to a Service Centre.

Symptom	Check	Action
The Motor Control Module will not power up.	Has circuit breaker 1, 2, 3, 4 or 5 tripped ? Has the thermistor control relay shut down the pumping system ? Has your electrical supply failed ?	Reset the circuit breaker (see Section 4.4.3). Reset the thermistor control relay (see Section 4.4.1) Rectify any problem found.
Circuit breaker 1 or 2 has tripped.	Is the corresponding overload setting correct ? Is there a short circuit ?	Check the corresponding overload setting and adjust if necessary. Rectify any wiring faults (refer to the circuit diagrams in Section 7).
There is no nitrogen flow to the QDP pump. The nitrogen supply solenoid-valve has not opened.	Has circuit breaker 6 tripped ?	Reset the circuit breaker (see Section 4.4.3).

Table 6 - Fault finding

6 STORAGE AND DISPOSAL

6.1 Storage

Store the Motor Control Module as follows :

1. Replace protective covers.
2. Store in cool dry conditions until required. When required, install the Motor Control Module as described in Section 3.

6.2 Disposal

Dispose of the Motor Control Module and any components safely in accordance with all local and national safety and environmental requirements.

7 ENGINEERING DIAGRAMS

The circuit diagrams for the Motor Control Modules are shown in Figures 5 and 6.

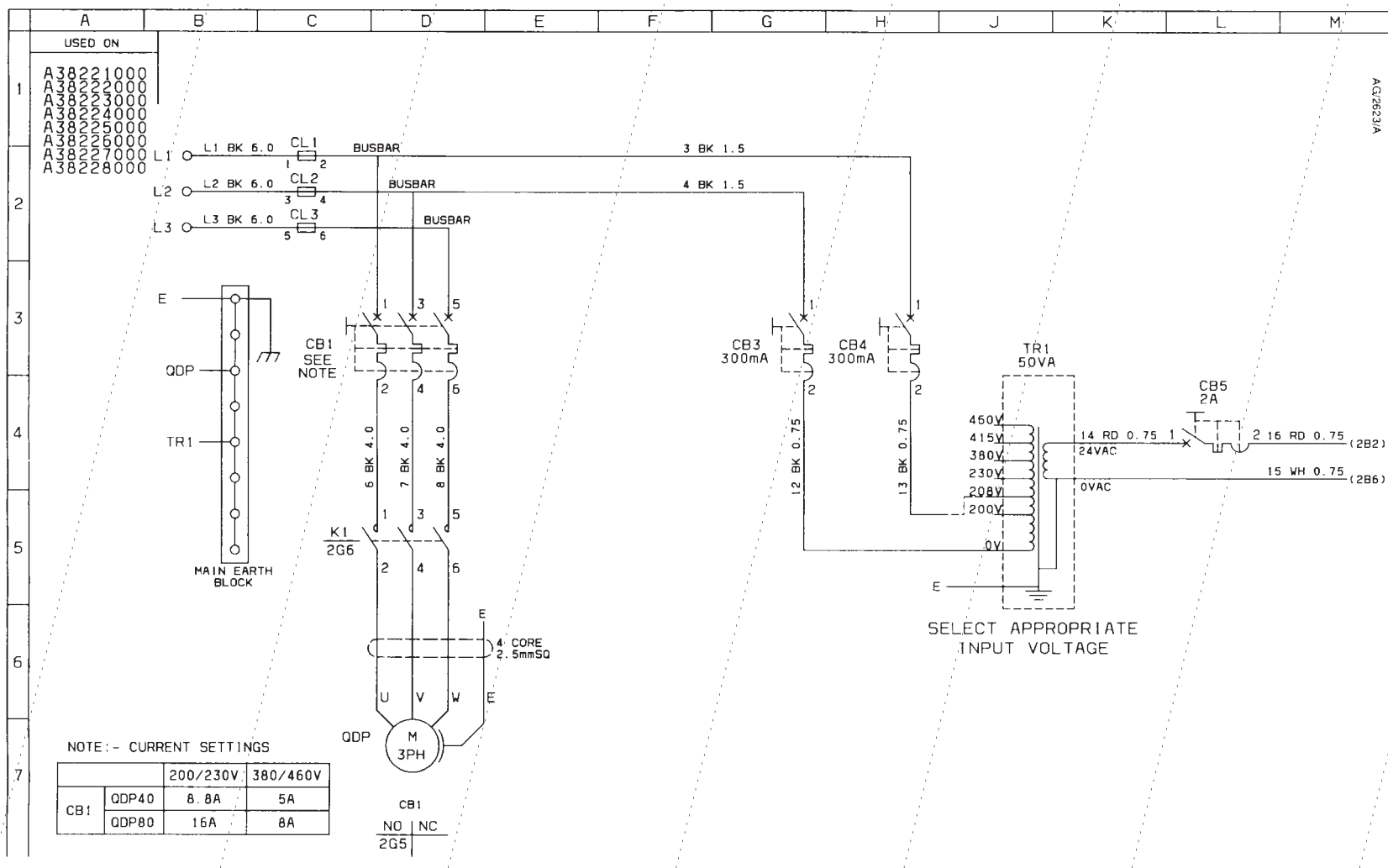

Figure 5 - Circuit diagram for the QDP Motor Control Module: sheet 1 of 3

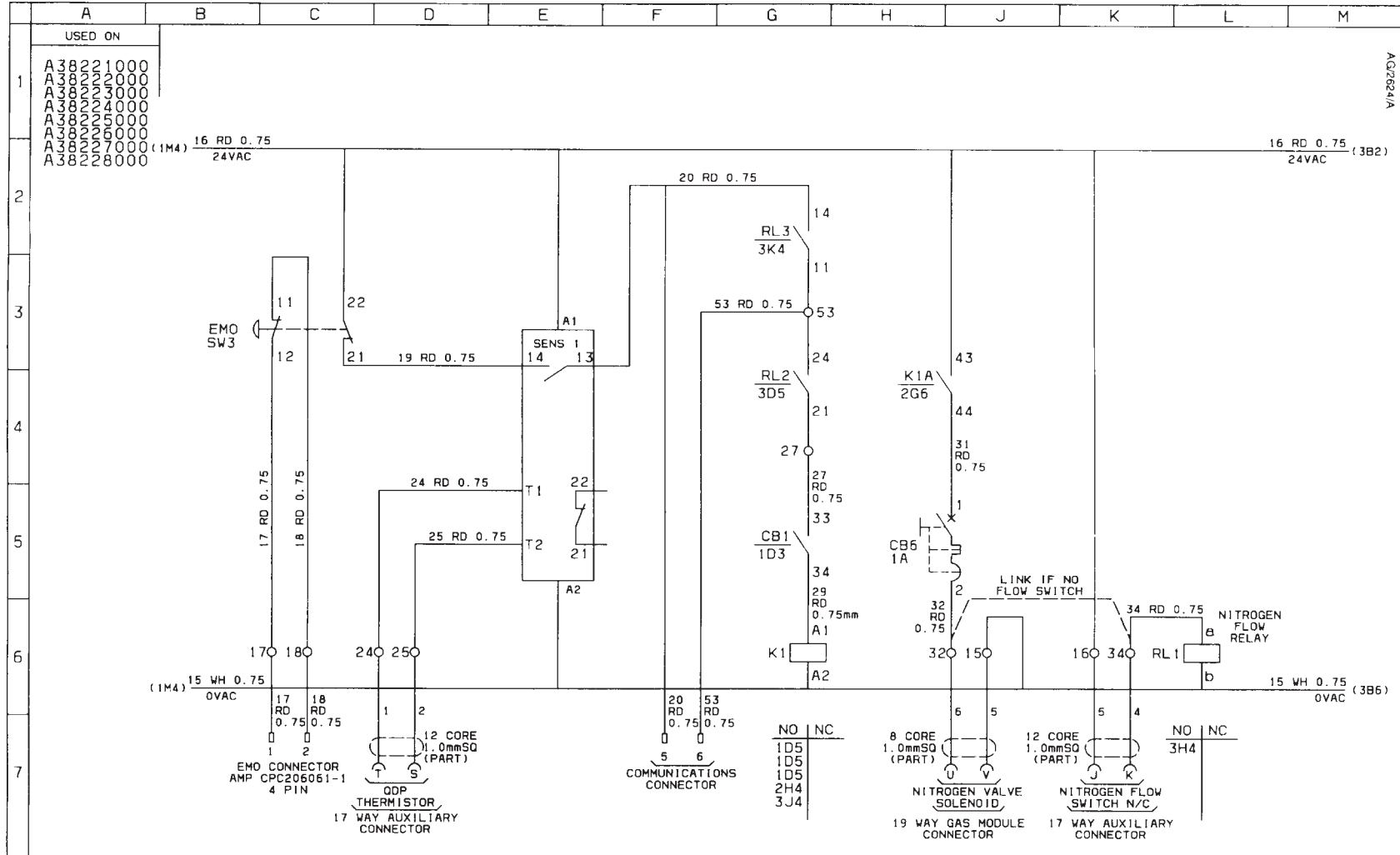

Figure 5 - Circuit diagram for the QDP Motor Control Module: sheet 2 of 3

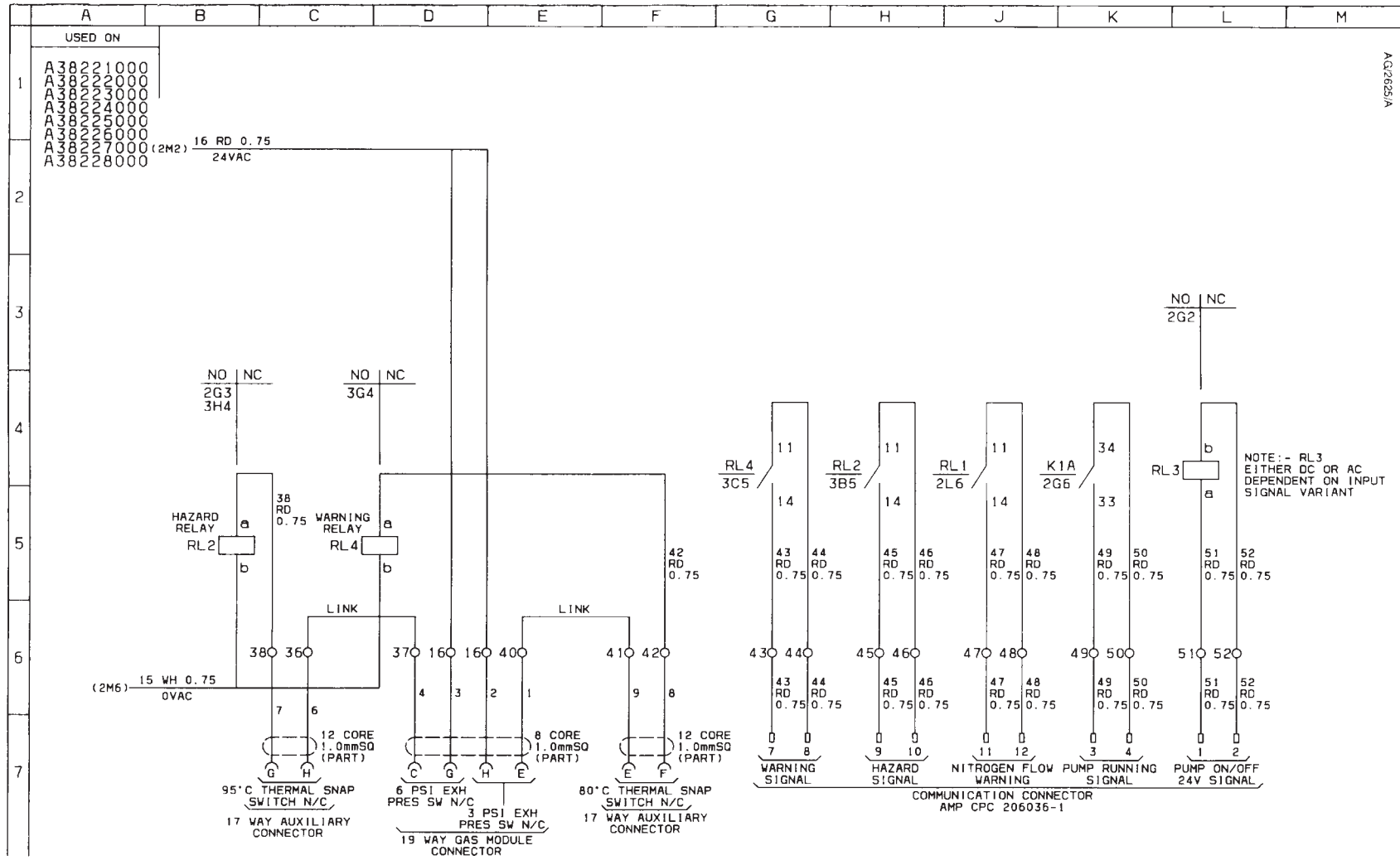
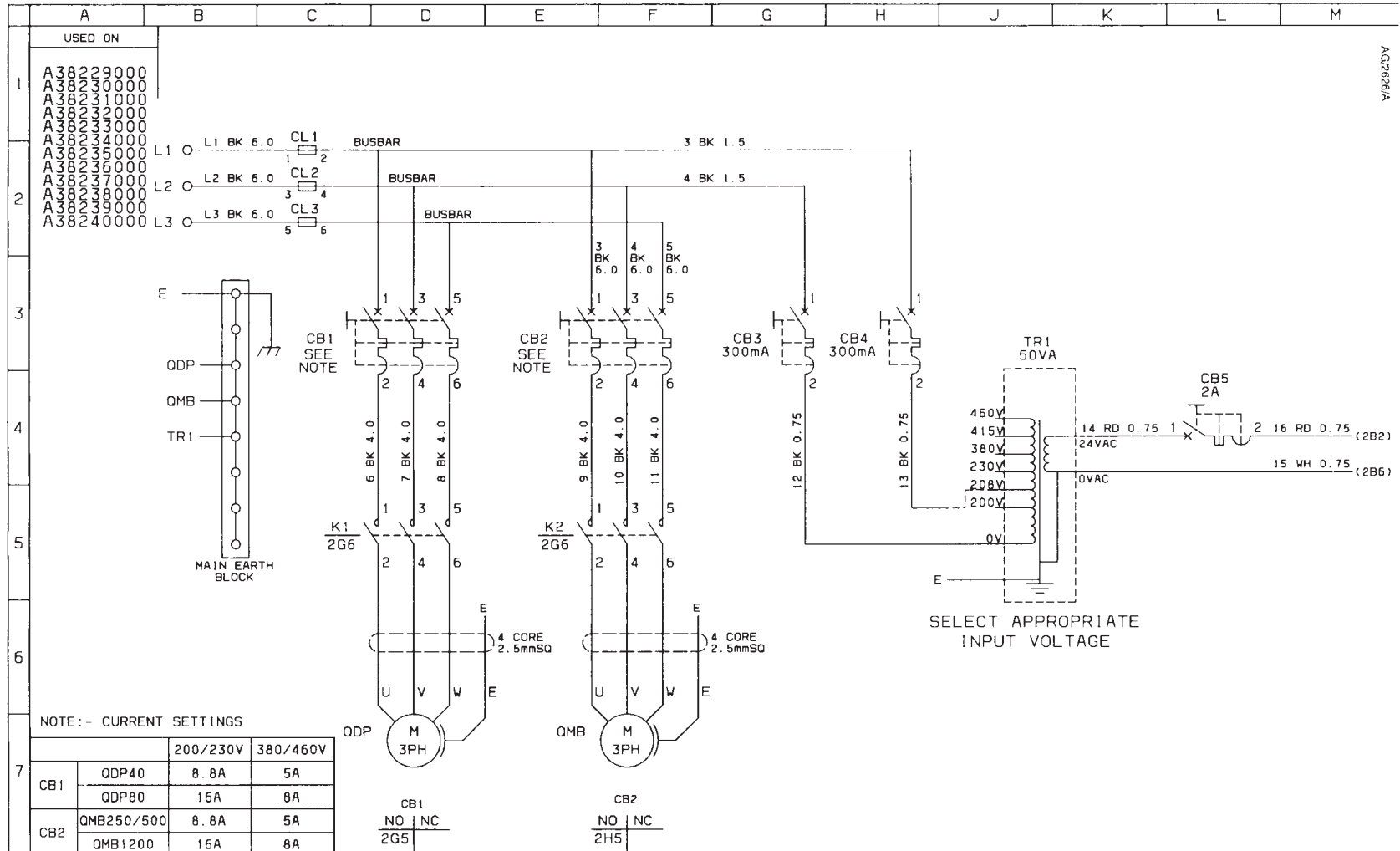

Figure 5 - Circuit diagram for the QDP Motor Control Module: sheet 3 of 3



AQ2626/A

Figure 6 - Circuit diagram for the QDP/QMB Motor Control Module: sheet 1 of 3

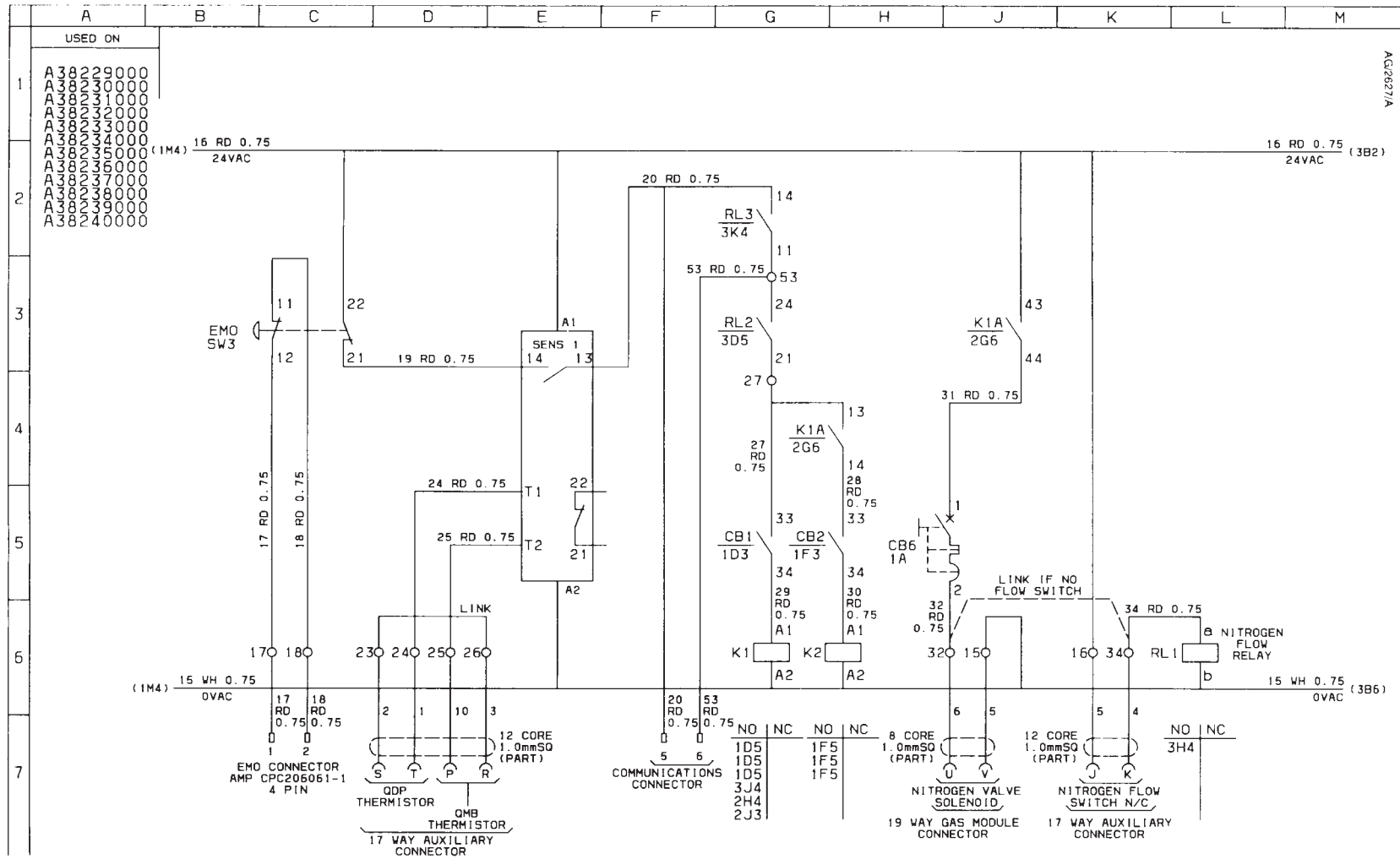

Figure 6 - Circuit diagram for the QDP/QMB Motor Control Module: sheet 2 of 3

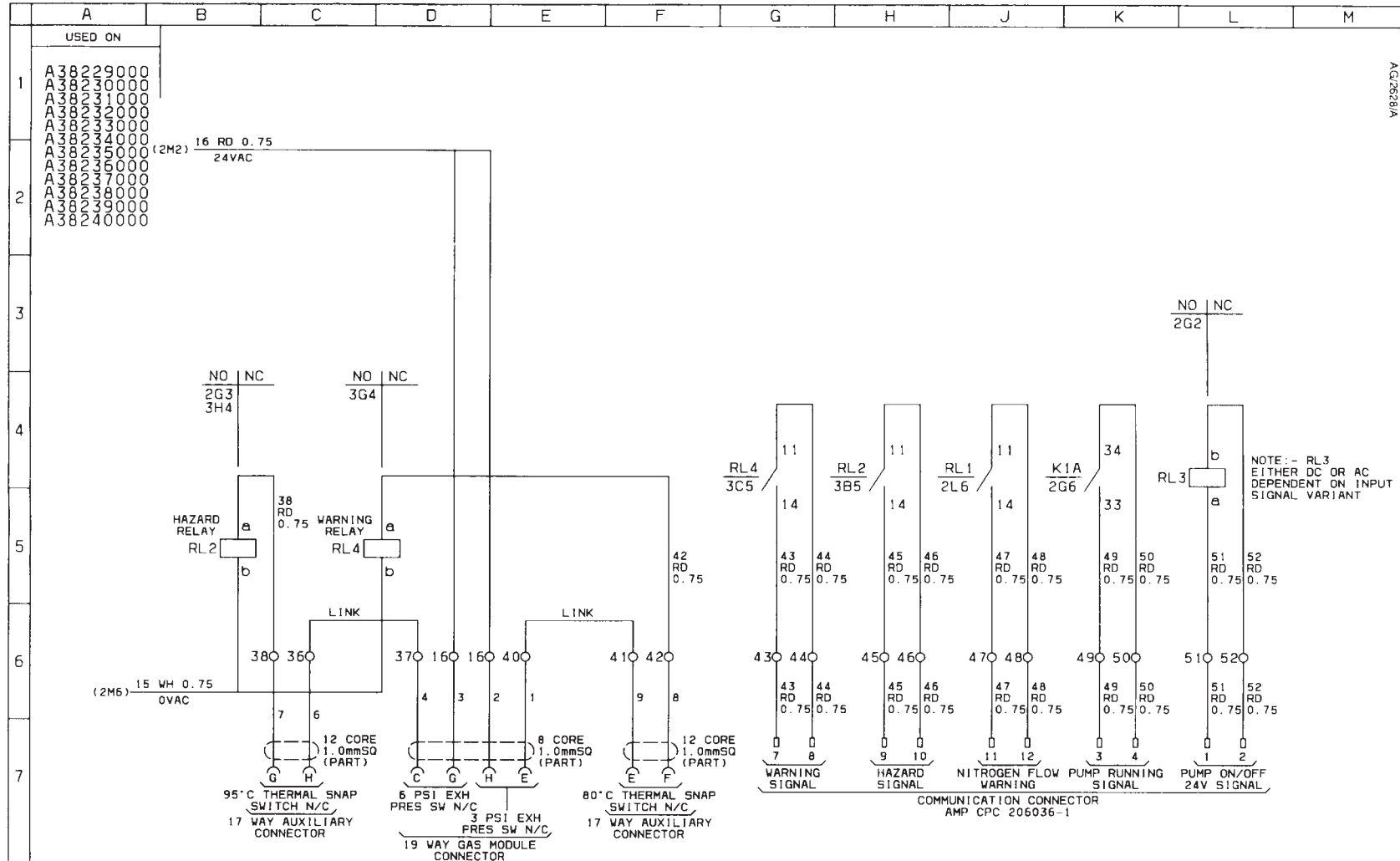

Figure 6 - Circuit diagram for the QDP/QMB Motor Control Module: sheet 3 of 3

