

Instruction Manual



EXC Turbomolecular Pump Controllers

Description

EXC120 Controller
EXC120E Controller
EXC300 Controller
EXC300M Controller

Item Number

D396-16-000
D396-17-000
D396-14-000
D396-15-000

 **BOC EDWARDS**

Declaration of Conformity

We, BOC Edwards,
Manor Royal,
Crawley,
West Sussex RH10 2LW, UK

declare under our sole responsibility that the product(s)

Turbomolecular Pump Controllers

| | |
|---------|-------------|
| EXC300 | D396-14-000 |
| EXC300M | D396-15-000 |
| EXC120 | D396-16-000 |
| EXC120E | D396-17-000 |

| | |
|-----------------------|-------------|
| and associated cables | D396-18-XXX |
| | D396-19-XXX |

to which this declaration relates is in conformity with the following standard(s)
or other normative document(s)

| | |
|--|--|
| EN61010-1:2001 | Safety Requirements for Electrical Equipment for Measurement, Control and Laboratory Use. |
| EN61326:1997 + A1:1998 + A2:2001 (Class B Emissions) | Electrical Equipment for Measurement, Control and Laboratory Use - EMC Requirements. |

following the provisions of

| | |
|----------------|--|
| 73 / 023 / EEC | Low Voltage Directive. |
| 89 / 336 / EEC | Electromagnetic Compatibility Directive. |



Dr. J.D. Watson, Director of Technology, VEMD

2 SEPTEMBER 2004 SHORHAM
Date and Place

This product has been manufactured under a quality system registered to ISO9001

CONTENTS

| Section | Title | Page |
|---------|---|------|
| 1 | INTRODUCTION | 1 |
| 1.1 | Scope and definitions | 1 |
| 1.2 | Description | 2 |
| 1.3 | Controls and indicators (EXC120/300/300M only) | 3 |
| 1.4 | Bakeout band control (EXC120/300/300M only) | 6 |
| 1.5 | Connection of an Active gauge | 7 |
| 1.6 | Backing pump control (EXC120/300/300M only) | 7 |
| 1.7 | Logic interface | 7 |
| 1.7.1 | Introduction | 7 |
| 1.7.2 | Electrical supplies | 8 |
| 1.7.3 | Control inputs | 8 |
| 1.7.4 | Status outputs | 10 |
| 1.7.5 | Analogue outputs | 10 |
| 1.8 | Vent-valve control | 10 |
| 1.8.1 | Introduction | 10 |
| 1.8.2 | Vent on Stop | 11 |
| 1.8.3 | Vent on Fail and Vent on Axial Emergency | 11 |
| 1.9 | Controller Fail conditions | 12 |
| 1.9.1 | General | 12 |
| 1.9.2 | Internal Timer | 12 |
| 1.9.3 | Axial Emergency (EXC300M only) | 13 |
| 1.10 | Electrical connections | 13 |
| 2 | TECHNICAL DATA | 17 |
| 2.1 | General | 17 |
| 2.2 | Operating and storage data | 17 |
| 2.3 | Mechanical data | 17 |
| 2.4 | Logic interface | 17 |
| 2.5 | Factory settings | 21 |
| 2.6 | Electrical connectors | 21 |
| 2.7 | Fuse ratings | 21 |
| 3 | INSTALLATION | 22 |
| 3.1 | Unpack and inspect | 22 |
| 3.2 | Fit the Controller | 23 |
| 3.3 | Introduction to Controller electrical connections | 23 |
| 3.4 | Connect the electrical supply | 27 |
| 3.5 | Connect additional earth (ground) bonding (if required) | 27 |
| 3.6 | Connect the EXT pump | 28 |
| 3.7 | Connect the backing pump (EXC120/300/300M only) | 28 |
| 3.8 | Connect the bakeout band (EXC120/300/300M only) | 29 |
| 3.9 | Connect an Active gauge | 30 |
| 3.10 | Connect the logic interface to your equipment | 30 |
| 3.11 | Adjust the Normal speed setpoint | 31 |

| Section | Title | Page |
|---------|--|------|
| 3.12 | Adjust the Internal Timer | 32 |
| 3.13 | Configure the Controller | 32 |
| 3.13.1 | Introduction | 32 |
| 3.13.2 | Enable/ disable the Internal Timer to monitor low pump speed | 32 |
| 3.13.3 | Vent options | 33 |
| 4 | OPERATION | 34 |
| 4.1 | Start-up | 34 |
| 4.2 | Standby | 34 |
| 4.3 | Bakeout band control (EXC120/300/300M only) | 35 |
| 4.4 | Operation with high inlet pressure | 35 |
| 4.5 | Operation with high pump temperature | 35 |
| 4.6 | The hours counter (EXC300 only) | 36 |
| 4.7 | Normal shutdown | 36 |
| 4.8 | Automatic shutdown after Fail condition | 37 |
| 4.9 | Reset the Controller after Fail condition | 37 |
| 4.10 | Electrical supply failure | 37 |
| 5 | MAINTENANCE | 38 |
| 5.1 | Safety | 38 |
| 5.2 | Replace a fuse | 38 |
| 5.2.1 | Introduction | 38 |
| 5.2.2 | Replace the electrical supply fuse | 38 |
| 5.2.3 | Replace the bakeout band fuse (EXC120/300/300M only) | 38 |
| 5.4 | Fault finding | 39 |
| 5.5 | Clean the Controller | 39 |
| 6 | STORAGE AND DISPOSAL | 39 |
| 6.1 | Storage | 39 |
| 6.2 | Disposal | 39 |
| 7 | SPARES AND ACCESSORIES | 40 |
| 7.1 | Introduction | 40 |
| 7.2 | Spares | 40 |
| 7.3 | Accessories | 40 |
| 7.3.1 | Pump-to-controller cable | 40 |
| 7.3.2 | BX bakeout band (EXC120/300/300M only) | 41 |
| 7.3.3 | TAV vent-valve | 41 |
| 7.3.4 | ACX air-cooler | 41 |
| 7.3.5 | Active vacuum gauges | 42 |
| 8 | ENGINEERING DIAGRAMS | 43 |
| | RETURN OF BOC EDWARDS EQUIPMENT | |

Illustrations

| Figure | Title | Page |
|--------|---|------|
| 1 | EXC120 Controller front panel | 4 |
| 2 | EXC300/300M Controller front panel (EXC300M shown) | 5 |
| 3 | Rear panel of the EXC120 Controller | 14 |
| 4 | Rear panel of the EXC120E Controller | 15 |
| 5 | Rear panel of the EXC300/300M Controller | 16 |
| 6 | EXC120/300/300M Controller dimensions (mm) | 19 |
| 7 | EXC120E Controller dimensions (mm) | 20 |
| 8 | Schematic diagram of EXC120 & EXC120E Controller electrical connections | 25 |
| 9 | Schematic diagram of EXC300 & EXC300M Controller electrical connections | 26 |
| 10 | Direct operation of the backing pump | 29 |
| 11 | Operation of the backing pump through a contactor | 29 |
| 12 | Top cover of the Controller | 31 |
| 13 | Hours counter (EXC300 only) | 36 |
| 14 | EXC120/120E/300 Controller to EXT pump connections | 43 |
| 15 | EXC300M Controller to EXT pump connections | 44 |
| 16 | Active Gauge connector | 45 |

Tables

| Table | Title | Page |
|-------|---|------|
| 1 | Technical data | 18 |
| 2 | Checklist of contents | 22 |
| 3 | Logic interface pins | 24 |
| 4 | Selection of vent-valve control options | 33 |
| 5 | Active Gauge connector pins | 45 |

Associated Publications

| Publication title | Publication Number |
|--|--------------------|
| EXT Pump Accessories | B580-66-880 |
| EXT70 and EXT250 Turbomolecular pumps | B722-01-880 |
| EXT351 and EXT501 Turbomolecular Pumps | B727-20-880 |
| EXT250M Turbomolecular Pump | B735-01-880 |

(This page deliberately left blank)

1 INTRODUCTION

1.1 Scope and definitions

This manual provides installation, operation and maintenance instructions for the BOC Edwards EXC120, EXC120E, EXC300 and EXC300M Turbomolecular Pump Controllers. You must use the Controller as specified in this manual.

Read this manual before you install and operate the Controller. Important safety information is highlighted as WARNING and CAUTION instructions; you must obey these instructions. The use of WARNINGS and CAUTIONS is defined below.

WARNING

Warnings are given where failure to observe the instruction could result in injury or death to people.

CAUTION

Cautions are given where failure to observe the instruction could result in damage to the equipment, associated equipment or process.

The units used throughout this manual conform to the SI international system of units of measurement.

In accordance with the recommendations of IEC1010, the following warning symbols appear on the Controller.



Caution - refer to accompanying documents



Caution - risk of electric shock



Protective conductor terminal

1.2 Description

The EXC Controller generates the electrical supply and the control signals necessary to operate an EXT pump and its accessories.

The Controller has a high-efficiency, auto-ranging power supply which adjusts itself to any external electrical supply in the specified voltage range (refer to Section 2). The power supply converts the single-phase electrical supply into a regulated d.c. electrical supply to control the operation of the EXT pump. The pump has three Hall effect devices which operate as rotor position sensors. These sensors ensure that the drive current is correctly commutated to the pump-motor phase-windings. The Hall effect devices also generate a speed signal which the Controller uses to regulate the rotational speed of the pump.

The Controller has a secondary regenerative supply which uses the d.c. motor of the EXT pump as a generator. If the electrical supply fails, the regenerative supply provides the Controller with a back-up source of power without the need for batteries. All Controllers use the regenerative supply to maintain the electrical supply to the vent-valve until the pump speed falls to below 50% of full rotational speed (see Section 1.8). The EXC300M Controller also uses the regenerative supply to provide sufficient power to the electromagnetic bearings of the EXT250M pump until the rotational speed of the pump is low enough for the pump rotor to drop onto the safety bearings.

The Controllers have a number of safety features which limit the power supplied to the EXT pump in the event of sustained high pressure or temperature:

- If the EXT pump inlet pressure rises, the power supplied to the pump-motor increases to counteract the gas frictional load. The pump rotational speed remains constant until the Controller peak power level is reached; beyond this power level, the speed of the pump starts to reduce. If the pump speed falls to below 50% of its full rotational speed, the Controller may trip into Fail condition, depending on how you have configured the Controller (see Section 1.9.2).
- If the Controller detects that its temperature or the pump temperature is too high, it reduces the power supplied to the pump-motor; the pump may not therefore be able to maintain full rotational speed if it is too hot. If the pump speed falls to below 50% of its full rotational speed, the Controller may trip into Fail condition, depending on how you have configured the Controller (see Section 1.9.2).

You can use the EXC120, EXC300 and EXC300M Controllers as stand-alone controllers. Alternatively, you can connect the Controller to your own equipment; you can then use either the Controller or your own equipment to control the system.

The EXC120E Controller has no front-panel controls and can only be operated through the logic interface. You must therefore connect an EXC120E Controller to your own control equipment.

1.3 Controls and indicators (EXC120/300/300M only)

Note: In addition to the controls and indicators on the front panel, the EXC120, EXC300 and EXC300M Controllers have an electrical supply isolator on the rear panel (see Figures 3 to 5).

The controls and indicators on the front panel of the EXC120, EXC300 and EXC300M Controllers are shown in Figures 1 and 2 and are described below.

Start/Stop

Use this latching button to alternately Start or Stop the EXT pump. A LED on the button goes on when EXT Start has been selected. Note that:

- The button is wired in series with the Start/Stop input on the logic interface (see Section 1.7.3). The EXT pump will not start until Start is selected from this front panel button **and** the Start/Stop input is closed. The Controller is supplied with a wire link to close the Start/Stop input.
- If the LED on the button is on, it only means that Start has been selected; it does not necessarily mean that the pump has successfully started.
- The Controller delays the Start operation until the Interlocks are closed (refer to Section 1.7.3); therefore, the EXT pump will not necessarily start to operate when you select Start. If you select Start and the Interlocks are not closed, the LED on the button will flash.

This button is also used to reset the Controller after Fail or Axial Emergency condition (see Section 4.9).

Standby

Use this latching button to select pump Standby mode at any time. In Standby, the rotational speed of the EXT pump is reduced to 70% of its full rotational speed. Selection of Standby prolongs the life of the pump bearings. Note that:

- The button is wired in parallel with the Standby input on the logic interface (see Section 1.7.3) and you can use either the button or the input to select Standby.
- The LED on the button is on when Standby is selected (either by the button or by the Standby input).

Heater

Use this switch to switch on the electrical supply to the bakeout band. Note that the Controller only switches on the electrical supply to the bakeout band when the EXT pump speed reaches the Normal speed setpoint (see Section 1.7.4).

The LED on the switch is on when the electrical supply to the bakeout band is switched on; this LED can therefore be used as an indication that the pump has reached Normal speed.

AW/1538/A

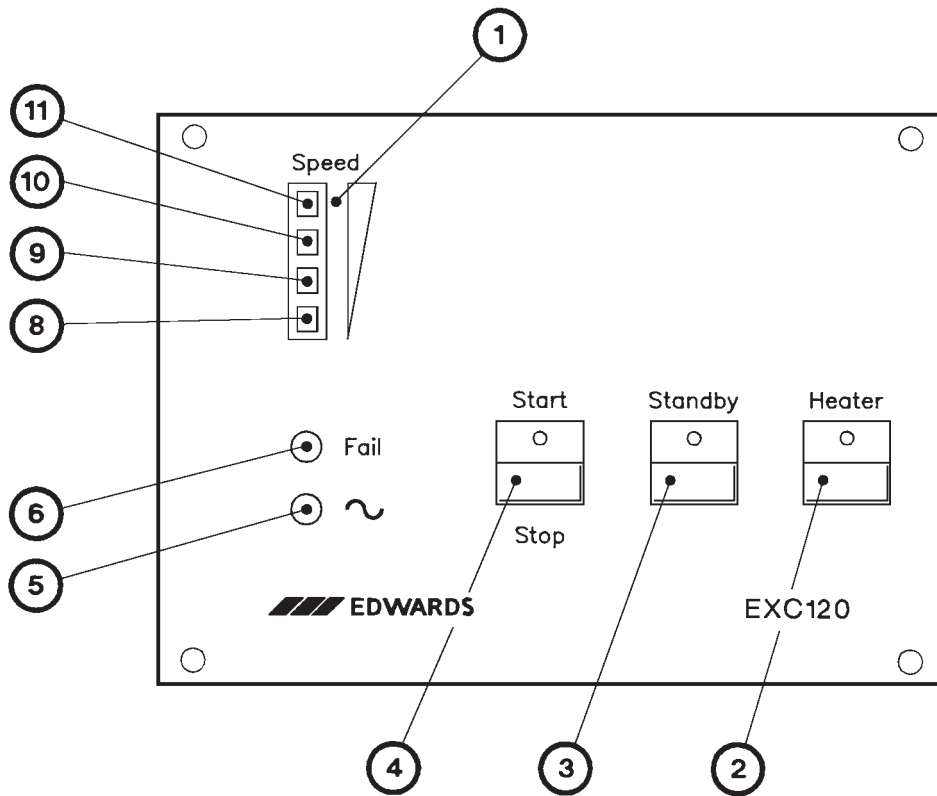

- | | |
|---------------------------------|---------------------------------|
| 1. Speed indicator | 7. Not used |
| 2. Heater (bakeout band) switch | 8. Pump rotating LED (amber) |
| 3. Standby button | 9. Pump speed >25% LED (amber) |
| 4. Start/Stop button | 10. Pump speed >50% LED (green) |
| 5. Electrical supply LED | 11. Pump speed >75% LED (green) |
| 6. Fail LED | |

Figure 1 - EXC120 Controller front panel

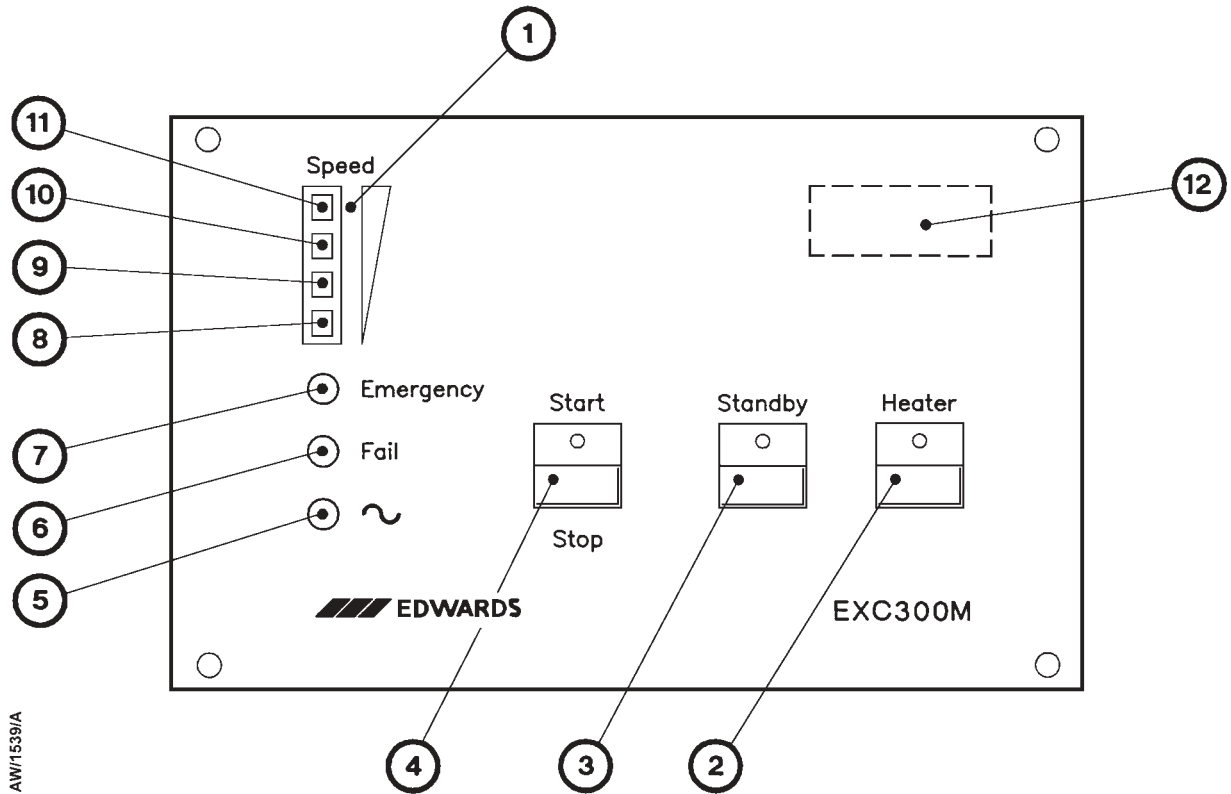

- | | |
|---------------------------------|---------------------------------|
| 1. Speed indicator | 7. Emergency LED (EXC300M only) |
| 2. Heater (bakeout band) switch | 8. Pump rotating LED (amber) |
| 3. Standby button | 9. Pump speed >25% LED (amber) |
| 4. Start/Stop button | 10. Pump speed >50% LED (green) |
| 5. Electrical supply LED | 11. Pump speed >75% LED (green) |
| 6. Fail LED | 12. Hours counter (EXC300 only) |

Figure 2 - EXC300/300M Controller front panel (EXC300M shown)

Speed

The speed indicator has 4 LEDs which go on to indicate the rotational speed of the EXT pump. Each LED goes on when the speed of the pump is above a certain value, represented as a percentage of the full operating speed of the pump.

Refer to Figures 1 and 2: the bottom LED (8) goes on as soon as the pump rotor starts to rotate; the next LED (9) goes on when the rotational speed is > 25% of full rotational speed. The first green LED (10) goes on when the speed is > 50% of full rotational speed; the top LED (11) goes on when the speed is > 75% of full rotational speed. Note that:

- When the pump starts, the bottom LED goes on as soon as the pump rotor starts to rotate.
- When the pump decelerates, the bottom LED goes off as soon as the pump speed falls to below 10% of full rotational speed.
- When only the bottom two LEDs are on, the pump speed is below 50% of its full rotational speed and the Controller may trip into Fail condition, depending on how you have configured the Controller (see Section 1.9.2).
- When the pump is at Standby rotational speed, the top LED is off.

Emergency

This LED is only available on the EXC300M Controller. When the LED is on, this indicates an Axial Emergency condition (refer to Section 1.9.3).

Fail

This LED is on when the Controller has tripped into Fail condition (refer to Section 1.9).

~

This LED is on when the Controller is connected to the electrical supply and the electrical supply isolator on the rear of the Controller (see Figures 3 and 5) is switched on.

Hours counter

This counter is only available on the EXC300 Controller. The counter shows the total elapsed time that the EXC300 Controller has operated an EXT pump.

1.4 Bakeout band control (EXC120/300/300M only)

The EXC120, 300 and 300M Controllers can be used to operate a bakeout band.

The Controller will switch on the electrical supply to the bakeout band when the Heater switch on the front panel is switched on and the EXT pump is at Normal speed (refer to Sections 1.3 and 1.7.4).

1.5 Connection of an Active gauge

Note: If you connect a BOC Edwards Active gauge to operate the TMPI control input signal to the logic interface, you cannot also use another signal to operate the TMPI control input.

You can directly connect a BOC Edwards Active gauge to the Controller (refer to Section 7 for suitable gauges). For example:

- You can use the set-point facility of an APG Active Pirani Gauge or an ATC Active Thermocouple Gauge (which is used to measure system or backing pressure) to operate the TMPI control input signal to the logic interface.
- You can connect an AIM Active Inverted Magnetron Gauge and use the Controller TMP Normal signal to switch the gauge on. This allows you to control the AIM Gauge without the need to use an additional high pressure gauge (and its associated control equipment) to interlock the operation of the AIM Gauge to system pressure.

Refer to Section 3.9 for details of the connection of an Active gauge to the Controller.

If you want to use any alternative gauges, you must connect the gauge to its associated control equipment and then connect the set-point output of the control equipment to the logic interface.

1.6 Backing pump control (EXC120/300/300M only)

The EXC120, EXC300 and EXC300M Controllers can be used to control the operation of a backing pump through a backing pump relay. The operation of this relay depends on how you have configured the Controller to operate the vent-valve: refer to Sections 1.8 and 3.13.

1.7 Logic interface

1.7.1 Introduction

The rear panel of the Controller has a logic interface connector (see Figures 3 to 5) which you can use to connect the Controller to your own equipment. The EXC120 and EXC120E Controllers have a 17-way connector and the EXC300 and EXC300M Controllers have an 18-way connector.

Signals on the logic interface are of four types:

- **Electrical supplies** These are electrical supplies for accessories connected to your pump; that is, the vent-valve and the air-cooler.
- **Control inputs** These are switch-type input signals which are used to control the operation of the pumping system.
- **Status outputs** These outputs identify the status of the pump and the Controller.
- **Analogue output** The speed output provides an indication of the EXT pump speed.

Refer to Table 3 and to Figures 8 and 9 for detailed information about the logic interface pins and their uses. A general description of the logic interface connections follows.

1.7.2 Electrical supplies

Two 24 V supplies are provided, as described below:

Vent-valve supply

This electrical supply is provided to operate a vent-valve fitted to your EXT pump or vacuum system. The Controller automatically opens the valve when the speed of the pump falls to below 50% of full rotational speed (see Section 1.8). You can also configure the Controller to operate the valve in other specific conditions: refer to Sections 1.8 and 3.13.

Air-cooler supply

This electrical supply is provided to operate an ACX air-cooler fitted to your EXT pump. The electrical supply is on whenever the Controller is on. If your pump is water-cooled, you can use this supply to operate a solenoid-valve to control the flow of water through the water-cooler.

1.7.3 Control inputs

Note: The Controller is supplied with wire links fitted to close the TMP and SYS Interlocks and to close the Start/Stop input. The Controller cannot start the EXT pump if any of these three inputs are open.

You can use these signals to control the operation of the EXT pump. The signals are switch-type inputs in which two pins on the logic interface are linked (closed) when you want to set the required signal and are unconnected (open) when you do not wish to set the signal.

Two of the inputs (Start/Stop and Standby) have the same functions as the buttons of the same name on the Controller front panel (on EXC120, EXC300 and EXC300M Controllers). The other two inputs are Interlocks and the Controller will only operate the EXT pump if both Interlocks are closed (and if no Fail condition is present).

Start/Stop

Use the Start/Stop input to Start and Stop the EXT pump. Note that on the EXC120, EXC300 and EXC300M Controllers, the signal is wired in series with the Start/Stop button on the front panel, so you must close the Start/Stop input **and** press the Start/Stop button on the front panel to Start the pump. To stop the pump, either open the input (that is, open the link between the appropriate logic interface pins), or press the Start/Stop button again.

Standby

Close the Standby input to select pump Standby (refer to Section 1.3). Note that on the EXC120, EXC300 and EXC300M Controllers, the Standby input is wired in parallel with the Standby button on the front panel and you can use either the button **or** the input to select Standby at any time.

TMP Interlock (TMPI)

Use the TMP Interlock to delay the start of the EXT pump until the backing pump has sufficiently reduced the pressure in the vacuum system. You can therefore control the TMP Interlock either by a timer or by a pressure switch in the backing pipeline of your system. Note that:

- If the TMP Interlock is open when Start is selected, the Start LED on the Start/Stop button will flash.
- If the TMP Interlock is opened after Start is selected, but with the SYS Interlock open, the Start LED will continue to flash.
- If the TMP Interlock is opened after the EXT pump has started, the Controller will trip into Fail condition.

SYS Interlock (SYSI)

Note: The EXC120E Controller does not have a backing pump relay.

Use the SYS Interlock to interlock the Controller to a system fail or control signal, for example, a position switch on a door of the vacuum chamber or a start contactor for a backing pump.

When the SYS Interlock opens:

- the backing pump relay opens (see Section 1.8)
- the electrical supply to the vent-valve is switched off (see Section 1.8).

Note that:

- If the SYS Interlock is open when Start is selected, the Start LED on the Start/Stop button will flash.
- If the SYS Interlock is opened after Start has been selected, but with the TMP Interlock open, the Start LED will continue to flash.
- If the SYS Interlock is opened after the EXT pump has started, the Controller will trip into Fail condition. If the SYS Interlock then closes again, the vent option you have selected (refer to Sections 1.8 and 3.13) will determine the operation of the backing pump relay and the electrical supply to the vent-valve.

1.7.4 Status outputs

The Controller provides Normal and Fail status output signals (TMP Normal and TMP Fail) through volt-free contacts on the logic interface connector. The EXC300M Controller also provides an Axial Emergency condition signal (also on a volt-free contact). These signals can be used to control devices in the pumping system or provide remote status output signals. The signals operate as described below.

| | |
|---------------------------------------|---|
| TMP Normal | TMP Normal is normally open and closes when the EXT pump speed reaches the Normal speed setpoint. The Normal speed setpoint is determined by a potentiometer on the top of the Controller. The Controller is supplied with the potentiometer adjusted so that the Normal speed setpoint is 80% of full rotational speed. You can adjust the Normal speed setpoint as described in Section 3.11. |
| TMP Fail | TMP Fail is normally closed and opens when the Controller trips into Fail condition (see Section 1.9). |
| Axial Emergency (EXC300M only) | Axial Emergency is normally closed and opens when an Axial Emergency is detected (see Section 1.9.3). |

1.7.5 Analogue outputs

The Pump Speed analogue output signal is proportional to EXT pump speed. Connect the output to a suitable meter or indicator to display the pump speed or connect the output to your control equipment (for example, to operate other components in the pumping system at preset EXT pump speeds).

1.8 Vent-valve control

1.8.1 Introduction

Notes: 1. The EXC120E Controller does not have a backing pump relay.

2. The vent option factory settings are shown in Table 4.

Provided that the SYS Interlock is closed: if the Controller electrical supply fails, the Controller maintains the electrical supply to the vent-valve until the pump speed falls to below 50% of full rotational speed. The Controller then switches off the vent-valve electrical supply and opens the backing pump relay. This feature of the Controller cannot be reconfigured.

However, you can use the configuration DIP switches on the Controller (refer to Section 3.13) to select any one of (or any combination of) the following options:

- Vent on Stop (Stop selected either by the front-panel button or the Start/Stop input on the logic interface).
- Vent on Fail condition.
- Vent on Axial Emergency condition (only available on the EXC300M Controller: see Section 1.9.3).

When a selected vent option condition is detected, the Controller:

- waits approximately 2 seconds, to allow a vacuum system isolation-valve (if fitted) to close,
- then switches off the electrical supply to the vent-valve,
- then opens the backing pump relay.

1.8.2 Vent on Stop

Note: If the SYS Interlock opens, a Fail condition will occur and the Controller will switch off the vent-valve electrical supply: see Sections 1.9.1 and 3.13.

Vent on Stop selected

When you switch on the Controller, the vent-valve electrical supply remains off until Start is selected. Provided that the SYS Interlock is closed, the Controller switches the vent-valve electrical supply on when Start is selected.

If Stop is then selected, the Controller switches the vent-valve electrical supply off again.

Vent on Stop not selected

When you switch on the Controller, the vent-valve electrical supply remains off until Start is selected. Provided that the SYS Interlock is closed, the Controller switches the vent-valve electrical supply on when Start is selected.

If Stop is then selected, the EXT pump will decelerate. The vent-valve electrical supply will remain on until the pump speed falls to below 50% of full rotational speed, at which point the vent-valve electrical supply will be switched off.

1.8.3 Vent on Fail and Vent on Axial Emergency

Note: The Vent on Axial Emergency option is only available on the EXC300M Controller.

If the Controller is configured to Vent on Fail or Vent on Axial Emergency, the Controller will switch off the vent-valve electrical supply as soon as Fail condition or Axial Emergency condition is detected.

1.9 Controller Fail conditions

1.9.1 General

The Controller will trip into Fail condition if any of the following occurs:

- The TMP or SYS Interlock opens while the EXT pump is operating (see Note 1 below).
- The EXT pump does not reach 50% of full rotational speed within a preset time after it starts (the time set by the adjustable Internal Timer: see Sections 1.9.2 and 3.12).
- The EXT pump speed falls to below 50% of its full rotational speed (see Note 2 below).
- The EXT pump speed is too high (above 1.07% of full rotational speed).
- The pump-to-controller cable is disconnected while the EXT pump is operating.

When the Controller trips into Fail condition, the electrical supply to the EXT pump-motor is switched off, the TMP Fail status output signal on the logic interface opens and (on the EXC120, EXC300 and EXC300M Controllers) the Fail LED on the front panel goes on. The operation of the vent-valve and backing pump relay depends on how you have configured the Controller (refer to Sections 1.8 and 3.13). To reset the Controller after Fail condition, refer to Section 4.9.

- Notes:
1. *If the Controller trips into Fail condition because the SYS Interlock has opened, the Controller will switch off the vent-valve electrical supply and (for the EXC120, EXC300 and EXC300M Controllers only) will open the backing pump relay. The operation of the vent-valve in other Fail conditions depends on how you have configured the Controller: refer to Sections 1.8 and 3.13.*
 2. *If you enable the Internal Timer (see Sections 1.9.2 and 3.13.2), the Controller will trip into Fail condition only after the preset time has elapsed.*

1.9.2 Internal Timer

Note: *The Internal Timer starts when the Controller starts the EXT pump, not when Start is selected (either by the front-panel button or the logic interface Start/Stop input). For example, if the Start button is pressed to start the pump when the TMP Interlock is open, the Internal Timer will only start when the Interlock closes and the Controller starts the pump.*

The Internal Timer has two functions:

Firstly, when the EXT pump is started by the Controller, the Internal Timer in the Controller also starts. If the EXT pump does not reach 50% of full rotational speed within the preset time measured by the timer, the Controller will trip into Fail condition. This function cannot be disabled.

Secondly, you can configure the Controller to enable or disable the Internal Timer if the pump speed falls during pump operation:

- If you disable the Internal Timer, the Controller will trip into Fail condition as soon as the pump speed falls to below 50% of full rotational speed.
- If you enable the Internal Timer, the Internal Timer will start as soon as the pump speed falls to below 50% of full rotational speed; the Controller will trip into Fail condition if the pump speed is still below 50% of full rotational speed at the end of the preset time.

The Controller is supplied with the Internal Timer enabled and adjusted for a preset time of 8 minutes. You can adjust the timer for your application: refer to Section 3.12.

1.9.3 Axial Emergency (EXC300M only)

The EXT250M pump has sensors which detect the axial displacement of the pump rotor; the outputs of these sensors are monitored by the Controller.

The Controller trips into Axial Emergency condition if:

- The displacement of the rotor exceeds set limits for more than 2 seconds.
- The displacement of the rotor repeatedly exceeds set limits (due to oscillation).

When the Controller trips into Axial Emergency condition, the electrical supply to the pump-motor is switched off, the Emergency LED on the front panel goes on and the Axial Emergency status output signal on the logic interface opens. The EXT250M pump electromagnetic bearings remain active, although the rotor assembly may contact the safety bearings if the axial loading exceeds the capabilities of the bearing drive.

1.10 Electrical connections

All electrical connections to the Controller are on the rear panel: see Figures 3 to 5.

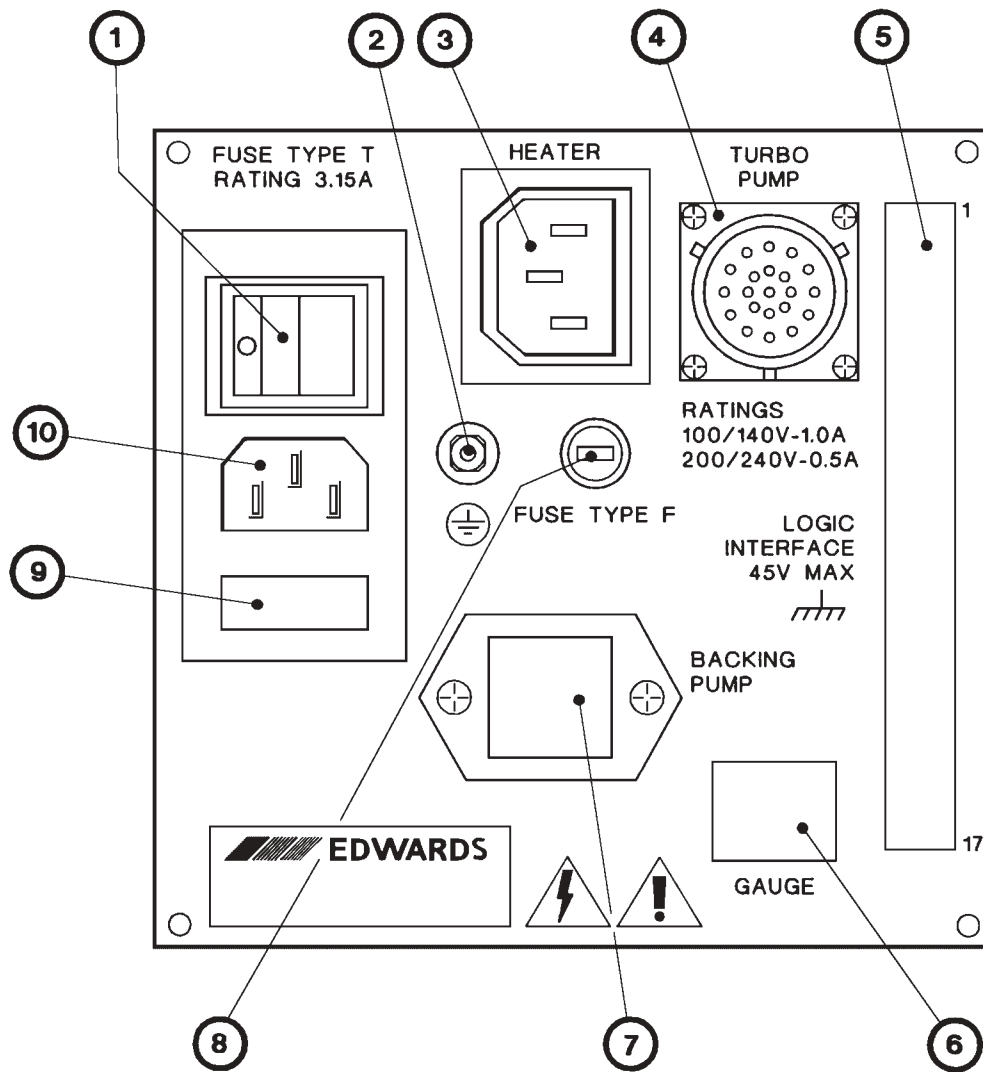

- | | |
|-------------------------------|---------------------------------|
| 1. Electrical supply isolator | 6. Active gauge connector |
| 2. Earth (ground) stud | 7. Backing pump connector |
| 3. Bakeout band connector | 8. Bakeout band fuse |
| 4. EXT pump connector | 9. Electrical supply fuse |
| 5. Logic interface connector | 10. Electrical supply connector |

Figure 3 - Rear panel of the EXC120 Controller

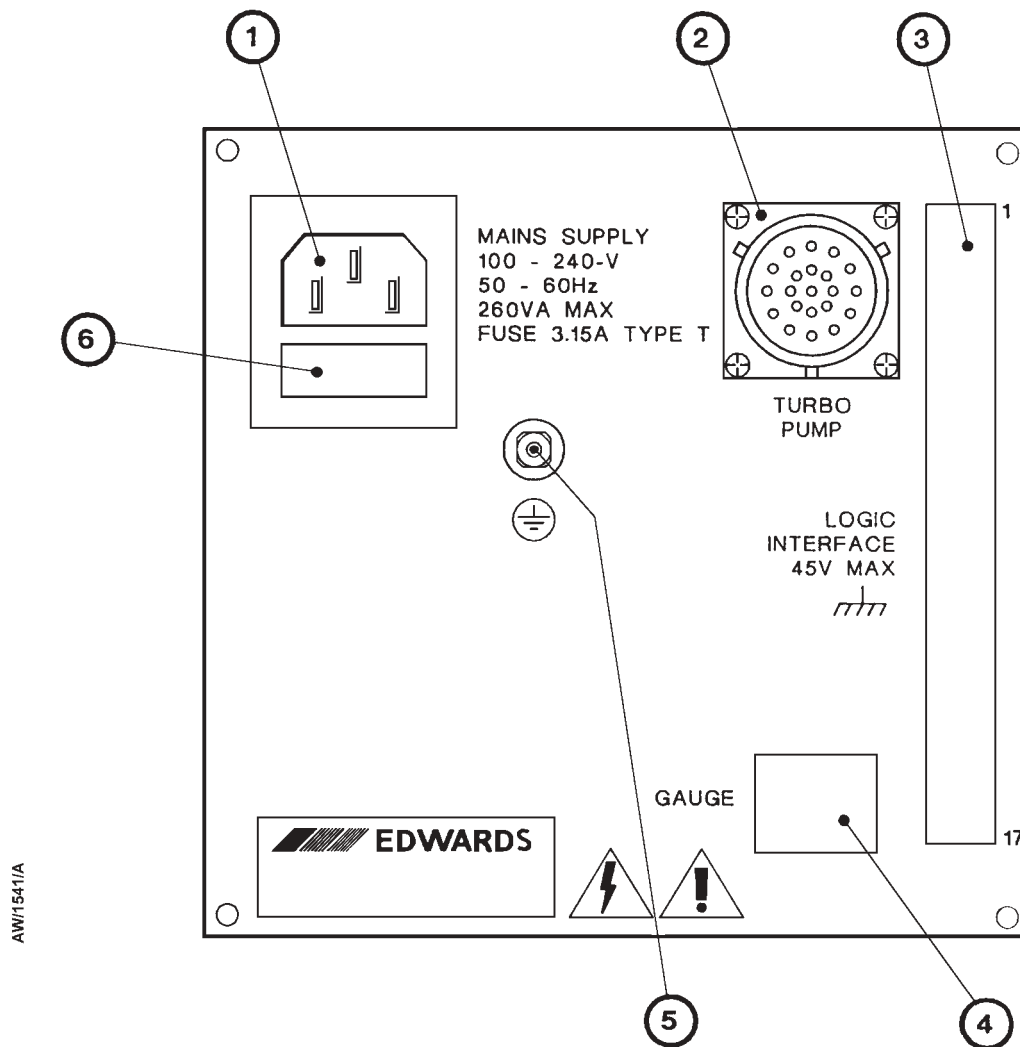

1. Electrical supply connector
2. EXT pump connector
3. Logic interface connector
4. Active gauge connector
5. Earth (ground) stud
6. Electrical supply fuse

Figure 4 - Rear panel of the EXC120E Controller

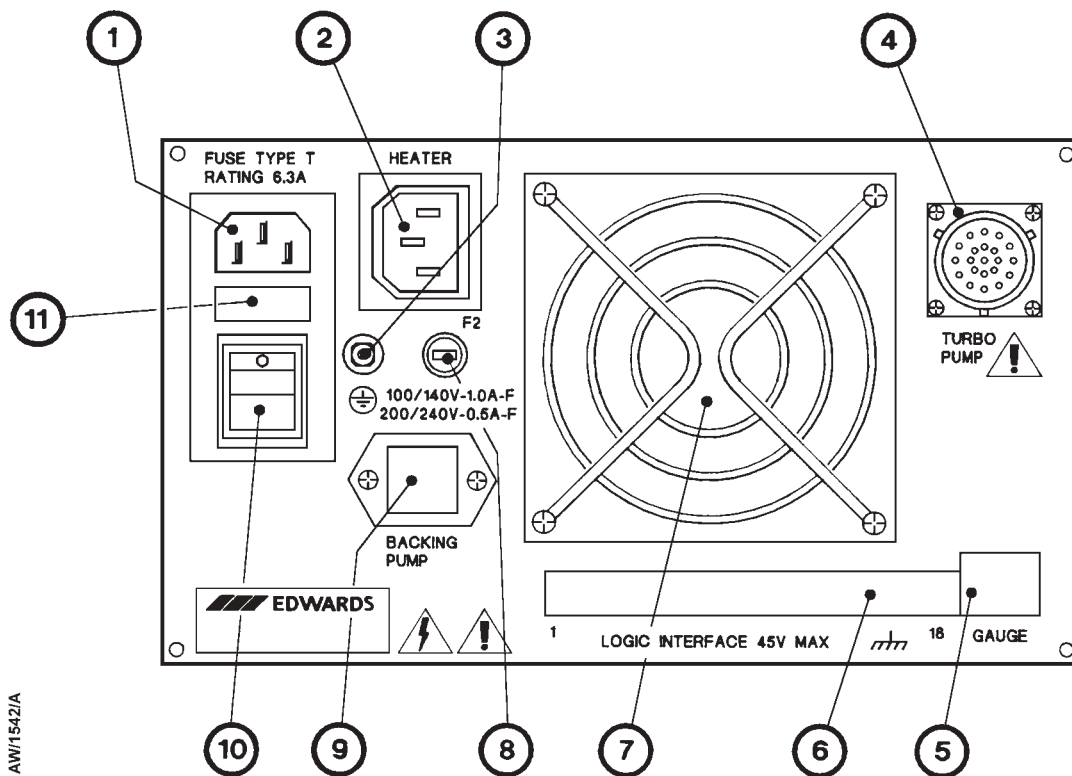

AW/1542/A

- | | |
|--------------------------------|--------------------------------|
| 1. Electrical supply connector | 7. Cooling-fan |
| 2. Bakeout band connector | 8. Bakeout band fuse |
| 3. Earth (ground) stud | 9. Backing pump connector |
| 4. EXT pump connector | 10. Electrical supply isolator |
| 5. Active gauge connector | 11. Electrical supply fuse |
| 6. Logic interface connector | |

Figure 5 - Rear panel of the EXC300/300M Controller

2 TECHNICAL DATA

Note: Unless otherwise specified, technical data in the following sections applies to all Controller models. Refer to Table 1 for other technical data.

2.1 General

| | |
|------------------|---|
| Performance data | See Table 1 |
| Electrical data | See Table 1 and Sections 2.4, 2.6 and 2.7 |

2.2 Operating and storage data

| | |
|-------------------------------------|--|
| Ambient operating temperature range | 0 to 35 °C |
| Ambient storage temperature range | -20 to +40 °C |
| Maximum ambient operating humidity | 10 to 95% RH (non-condensing to DIN 40040) |
| Maximum operating altitude | 3000 m |

2.3 Mechanical data

| | |
|------------|---------------------|
| Dimensions | See Figures 6 and 7 |
| Mass | See Table 1 |

2.4 Logic interface

| | |
|---------------------------------------|---|
| Relay contact rating (resistive load) | 1 A at 25 V d.c. |
| Remote control signals | |
| Control voltage: low (close) | < 0.8 V d.c. |
| Control voltage: high (open) | 4 to 24 V d.c. |
| Maximum input current (at 24 V) | 80 µA |
| Maximum output current (at 0 V d.c.) | 160 µA |
| Air-cooler electrical supply | See Table 1 |
| Vent-valve electrical supply | See Table 1 |
| Analogue EXT pump speed output | |
| Output voltage | 0 to +5 V d.c., proportional to EXT speed |
| Maximum output current | 5 mA |

| Parameter | EXC120 | EXC120E | EXC300 | EXC300M |
|--|--|--|--|--|
| Mass | 2 kg | 1.3 kg | 4.6 kg | 4.6 kg |
| Cooling | Natural convection | Natural convection | Forced air | Forced air |
| Electrical supply voltage | 90 to 264 V a.c. | 90 to 264 V a.c. | 90 to 132 or 180 to 264 V a.c. | 90 to 132 or 180 to 264 V a.c. |
| Electrical supply frequency | 47 to 63 Hz | 47 to 63 Hz | 47 to 63 Hz | 47 to 63 Hz |
| Maximum input power | 400 VA | 260 VA | 700 VA | 700 VA |
| Peak inrush current | 27 A at 110 V a.c. 54 A at 240 V a.c. | 27 A at 110 V a.c. 54 A at 240 V a.c. | 27 A at 110 V a.c. 54 A at 240 V a.c. | 27 A at 110 V a.c. 54 A at 240 V a.c. |
| Compatible EXT pumps | EXT70, EXT250 EXT351, EXT501 | EXT70, EXT250 EXT351, EXT501 | EXT70, EXT250 EXT351, EXT501 | EXT250M |
| EXT pump-motor electrical supply | | | | |
| Maximum continuous output power | 110 W | 110 W | 290 W | 290 W |
| Maximum output voltage | 90 V peak to peak | 90 V peak to peak | 90 V peak to peak | 90 V peak to peak |
| Switching frequency | 32 kHz | 32 kHz | 32 kHz | 32 kHz |
| Nominal commutation frequency | 600 Hz to 1.5 kHz | 600 Hz to 1.5 kHz | 600 Hz to 1.5 kHz | 600 Hz to 1.5 kHz |
| Maximum commutation frequency | 1.07 x nominal | 1.07 x nominal | 1.07 x nominal | 1.07 x nominal |
| Standby frequency | 70% of nominal | 70% of nominal | 70% of nominal | 70% of nominal |
| Maximum continuous axial bearing current | - | - | - | 4.75 A |
| Axial bearing drive voltage | | | | |
| Maximum | - | - | - | 26 V d.c. |
| Minimum | - | - | - | 10 V d.c. |
| Air-cooler electrical supply | | | | |
| Voltage range | +18 to +26 V d.c. | +18 to +26 V d.c. | +12 to +26 V d.c. | +12 to +26 V d.c. |
| Maximum output current | 100 mA | 100 mA | 100 mA | 100 mA |
| Vent-valve electrical supply | | | | |
| Voltage range | +18 to +26 V d.c. | +18 to +26 V d.c. | +12 to +26 V d.c. | +12 to +26 V d.c. |
| Maximum output current | 80 mA | 80 mA | 80 mA | 80 mA |
| Bakeout band electrical supply | | | | |
| Voltage range | 90 to 132 or 180 to 264 V a.c. | - | 90 to 132 or 180 to 264 V a.c. | 90 to 132 or 180 to 264 V a.c. |
| Maximum power | 150 W | - | 150 W | 150 W |

Table 1 - Technical data

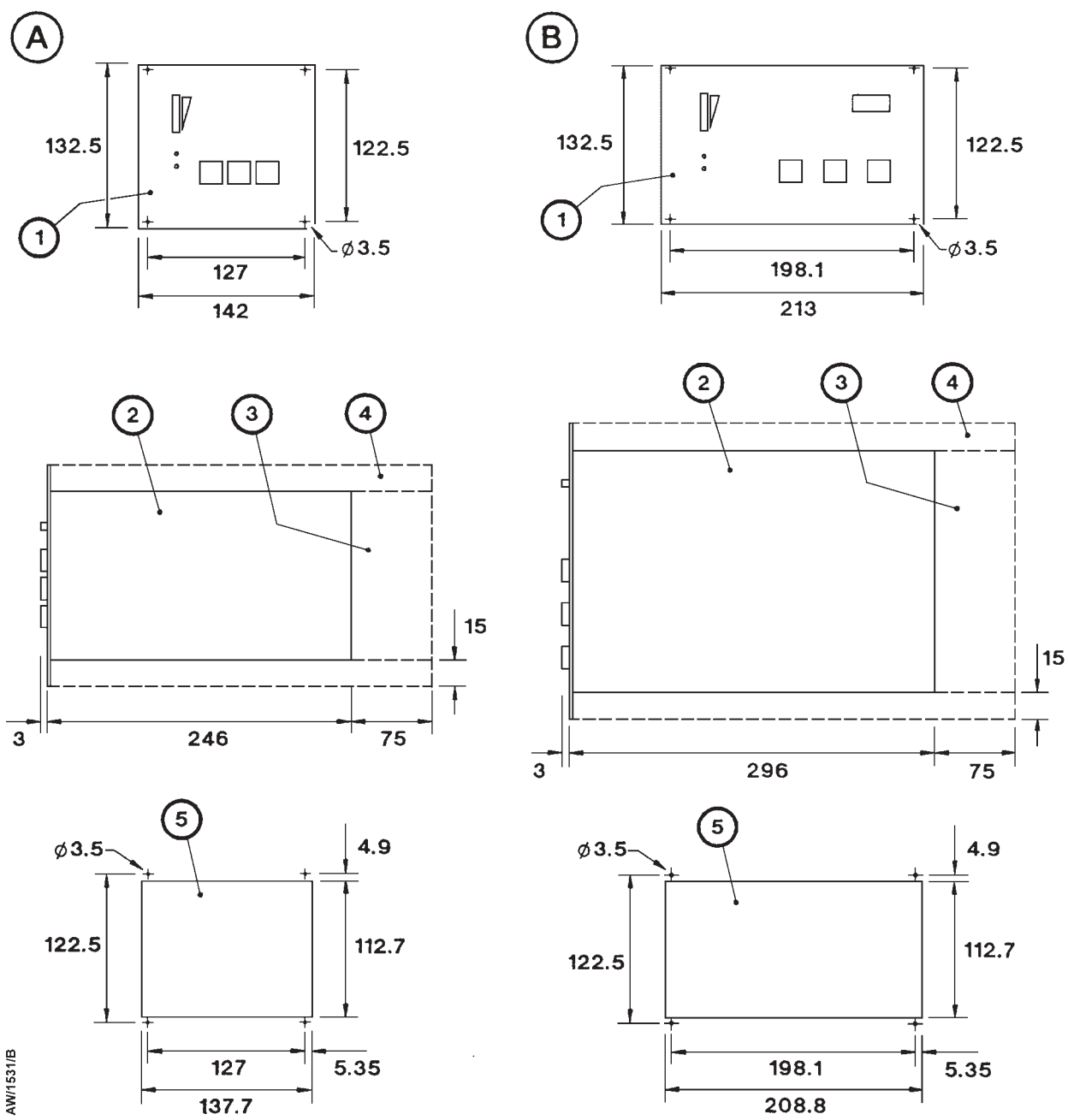

AW/1531/B

1. Front panel
2. View from top
3. Clearance for cables
4. Clearance for ventilation
5. Panel cut-out

- A EXC120
 B EXC300/EXC300M

Figure 6 - EXC120, EXC300 and EXC300M Controller dimensions (mm)

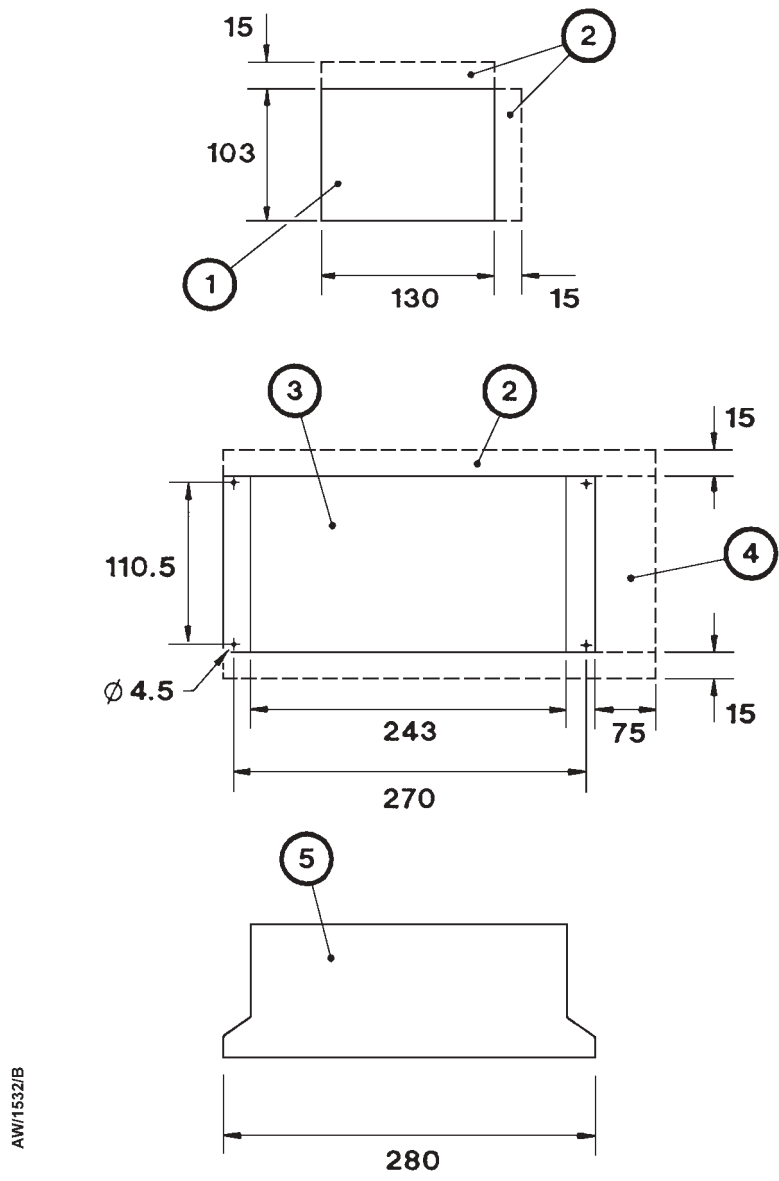

1. Front panel
2. Clearance for ventilation
3. View from top
4. Clearance for cables
5. Panel cut-out

Figure 7 - EXC120E Controller dimensions (mm)

2.5 Factory settings

| | |
|---|---|
| Normal speed setpoint | 80% of full rotational speed |
| Internal Timer | 8 min, enabled |
| Vent options | See Table 4 |
| Logic interface: pins linked on the mating connector | |
| EXC120/E | Pins 8 & 9, pins 12 & 13, pins 14 & 15 |
| EXC300/M | Pins 9 & 10, pins 13 & 14, pins 15 & 16 |

2.6 Electrical connectors

| | |
|---|---------------------------|
| Electrical supply connector socket type | CEE/IEC 320 |
| Earth (ground) stud (on rear panel) | M4 |
| Backing pump relay connector * | |
| Socket type | Stak 200 |
| Maximum voltage | 250 V a.c. |
| Maximum current (a.c. r.m.s. inductive load, 0.8 pf lagging) | 15 A |
| Bakeout band connector * | |
| Socket type | CEE/IEC/320 |
| Maximum power | 150 W |
| Active gauge connector | |
| Signals on the connector pins | See Figure 16 and Table 3 |
| Socket type | FCC68, 8-way |
| Manufacturer | Western Electric |
| Maximum power | 3 W |
| Logic interface connector | |
| Socket type (EXC120/120E/300M) | MVSTBR 2,5/17-st5,08 |
| Socket type (EXC300) | MVSTBR 2,5/18-st5,08 |
| Manufacturer | Phoenix Combicon |

2.7 Fuse ratings

| | |
|-------------------------------------|----------------------|
| Electrical supply fuse | |
| EXC120/EXC120E | 3.15 A, type T 20 mm |
| EXC300/EXC300M | 6.3 A, type T 20 mm |
| Bakeout band fuse * | |
| 90 to 132 V a.c. electrical supply | 1 A, type F 20 mm |
| 180 to 264 V a.c. electrical supply | 0.5 A, type F 20 mm |

* Not applicable to the EXC120E Controller.

3 INSTALLATION

3.1 Unpack and inspect

Remove all packing materials and check the Controller.

If the Controller is damaged, notify your supplier and the carrier in writing within three days; state the Item Number of the Controller together with your order number and your suppliers invoice number. Retain all packing materials for inspection. Do not use the Controller if it is damaged.

Check that your package contains the items listed in Table 2. If any of these items is missing, notify your supplier in writing within three days.

If the Controller is not to be used immediately, store the Controller in suitable conditions as described in Section 6.1.

| Qty | Description | Check (✓) |
|-----|---|--------------------------|
| 1 | EXC Controller | <input type="checkbox"/> |
| 1 | Backing pump relay electrical connector * | <input type="checkbox"/> |
| 1 | Security bracket for backing pump relay connector * | <input type="checkbox"/> |
| 1 | Logic interface electrical connector | <input type="checkbox"/> |
| 1 | Electrical supply cable | <input type="checkbox"/> |
| 1 | In-line filter † | <input type="checkbox"/> |
| 1 | Double-sided earth (ground) tab ▲ | <input type="checkbox"/> |

* Not supplied with the EXC120E Controller.

† Only supplied with the EXC300 and EXC300M Controllers.

▲ Only supplied with the EXC300M Controller; only needed if dual earth (ground) bonding is required.

Table 2 - Checklist of contents

3.2 Fit the Controller

WARNING

The Controller contains electrolytic capacitors and, under certain fault conditions, may emit dangerous fumes. Ensure that the Controller is operated in a well-ventilated area.

CAUTION

You must allow the correct clearances for air circulation and you must fit the EXC120E Controller onto a thermally conductive surface. If you do not, the performance of the Controller may be affected at high operating temperatures.

The Controller can be used on a bench-top or can be fitted in a rack or cabinet. You can operate the EXC120, EXC300 and EXC300M Controllers in a horizontal position or in a vertical position with the front panel at the top. You can operate the EXC120E Controller in a horizontal position or in a vertical position with the side vents at the top.

When you fit a Controller in a rack or a cabinet, you must allow 15 mm clearance at the sides of the Controller for air circulation and you must allow 75 mm clearance at the back of the Controller for the cables. Do not obstruct the cooling-fan on the EXC300 and EXC300M Controllers. The size of the front panel cut-out required and the location of the front panel fixing holes for the EXC120, EXC300 and EXC300M Controllers are shown in Figure 6.

When you fit the EXC120E Controller, you must firmly fit the Controller onto a thermally conductive material, for example aluminium or steel. The location of the bottom panel fixing-holes are shown in Figure 7.

3.3 Introduction to Controller electrical connections

When you make the electrical connections to the Controller described in the following sections, refer to Table 3 for full details of the logic interface connections and refer to Figures 8 and 9 which show schematic diagrams of the electrical connections. Take note of the following:

- The backing pump and bakeout band connectors are not available on the EXC120E Controller.
- The EXC120 and EXC120E Controllers have a 17-way logic interface connector. The EXC300 and EXC300M Controllers have an 18-way logic interface connector.

You must provide suitable strain-relief on the cables which you fit to the Controller.

| Pin number (EXC300/M) | Signal | Polarity* | Signal type | Pin number (EXC120/E) |
|--------------------------|---|-----------|-----------------|--------------------------|
| 1 | Vent-valve electrical supply: 24 V | + | Supply | 1 |
| 2 | Vent-valve electrical supply: 0 V ◆ | - | | 2 |
| 3 | Air-cooler electrical supply: 24 V | + | Supply | 3 |
| 4 | Air-cooler electrical supply: 0 V | - | | 4 |
| 5 | TMP Normal (closed when pump speed reaches the Normal speed setpoint) | N/A | Status outputs | 5 |
| 6 | TMP Fail (open when fail condition exists) | N/A | | 6 |
| 7 | Axial Emergency † (open when Axial Emergency condition exists) | N/A | | - |
| 8 | Status output isolated common | N/A | | 7 |
| ■ { 9 10 | Start/Stop: Close for Start | + | Control input | 8 } ■ |
| | | - | | 9 } ■ |
| 11 | Standby: Close for Standby | + | Control input | 10 |
| 12 | | - | | 11 |
| ■ { 13 14 | TMPI (TMP Interlock): Close for EXT pump operation | + | Control input | 12 } ■ |
| | | - | | 13 } ■ |
| ■ { 15 16 | SYSI (SYS Interlock): Close for backing pump operation | + | Control input | 14 } ■ |
| | | - | | 15 } ■ |
| 17 | Pump speed | - | Analogue output | 16 |
| 18 | | + | | 17 |

* + = positive, - = negative, N/A = not applicable.

† Only available on the EXC300M Controller.

◆ This supply line is raised to +24 V to de-energise the valve coil and vent the system.

■ The EXC Controller is supplied with these pins linked together on the mating connector.

Table 3 - Logic interface pins

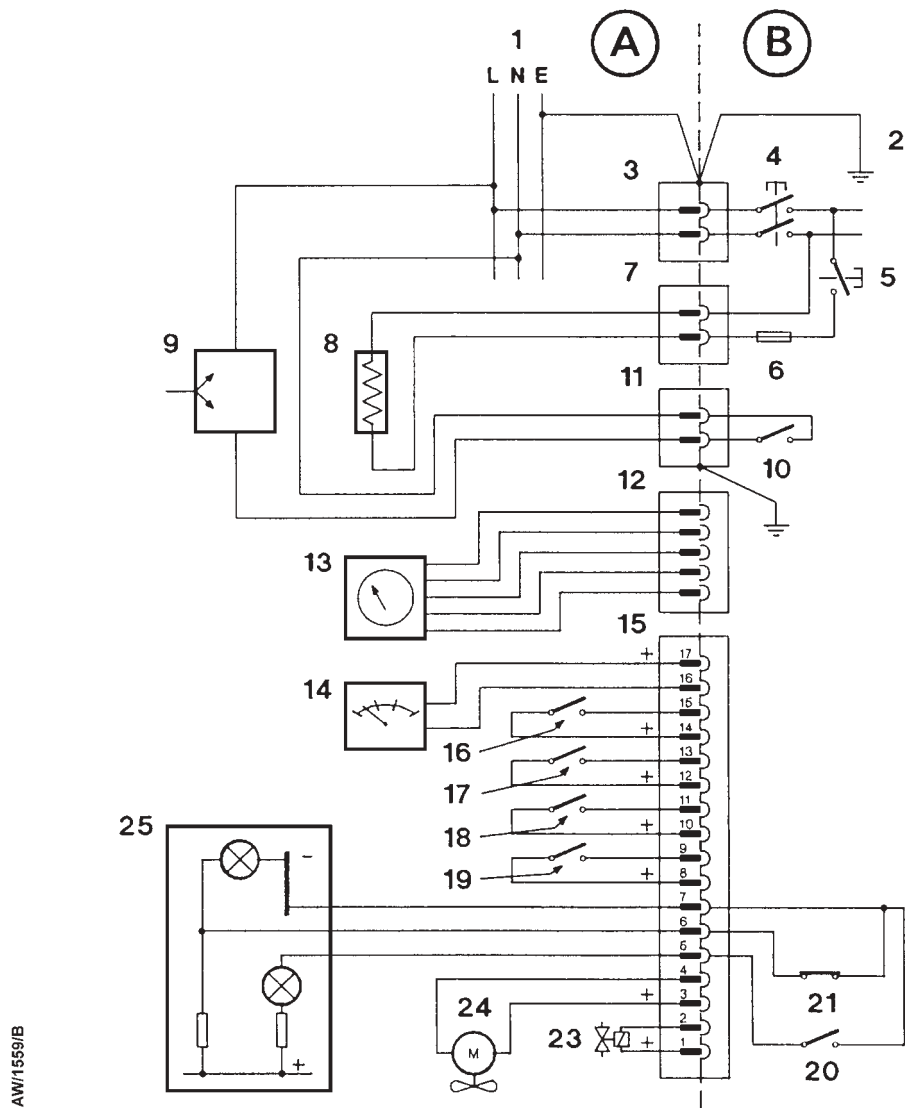

AW/1559/B

- | | | | | | |
|----|-------------------------------------|-----|---|-----|-----------------------------------|
| A | Vacuum and control system | L | Live electrical supply | 17. | External TMP Interlock switch |
| B | EXC Controller | N | Neutral electrical supply | 18. | External Remote Standby switch |
| | | E | Earth (ground) electrical supply | 19. | External Remote Start/Stop switch |
| 1. | External electrical supply | 10. | Backing pump relay * | 20. | TMP Normal output (normally open) |
| 2. | Earth (ground) | 11. | Rear panel backing pump relay connector * | 21. | TMP Fail output (normally closed) |
| 3. | Electrical supply connector | 12. | Rear panel Active gauge connector | 22. | Not used |
| 4. | Electrical supply isolator | 13. | Active gauge | 23. | Vent-valve |
| 5. | Front panel Heater switch * | 14. | Speed indicator | 24. | Air-cooler |
| 6. | Bakeout band fuse * | 15. | Logic interface connector | 25. | Remote indicator equipment |
| 7. | Rear panel bakeout band connector * | 16. | External SYS Interlock switch | | |
| 8. | Bakeout band * | | | | |
| 9. | Backing pump | | | | |

* Not available on the EXC120E Controller

Figure 8 - Schematic diagram of EXC120 & EXC120E Controller electrical connections

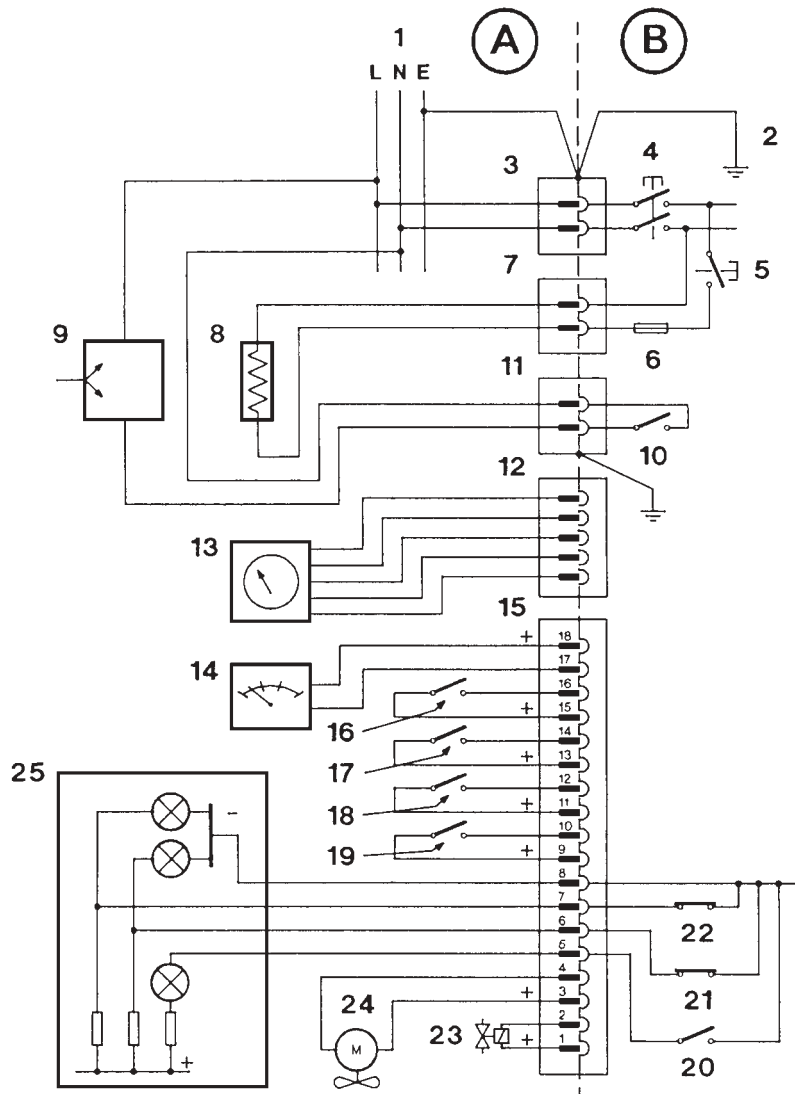

AW/1543/B

- | | | | | | |
|----|-----------------------------------|-----|---|-----|--|
| A | Vacuum and control system | L | Live electrical supply | 17. | External TMP Interlock switch |
| B | EXC Controller | N | Neutral electrical supply | 18. | External Remote Standby switch |
| | | E | Earth (ground) electrical supply | 19. | External Remote Start/Stop switch |
| 1. | External electrical supply | 10. | Backing pump relay | 20. | TMP Normal output (normally open) |
| 2. | Earth (ground) | 11. | Rear panel backing pump relay connector | 21. | TMP Fail output (normally closed) |
| 3. | Electrical supply connector | 12. | Rear panel Active gauge connector | 22. | Axial Emergency output (normally closed) * |
| 4. | Electrical supply isolator | 13. | Active gauge | 23. | Vent-valve |
| 5. | Front panel Heater switch | 14. | Speed indicator | 24. | Air-cooler |
| 6. | Bakeout band fuse | 15. | Logic interface connector | 25. | Remote indicator equipment |
| 7. | Rear panel bakeout band connector | 16. | External SYS Interlock switch | | |
| 8. | Bakeout band | | | | |
| 9. | Backing pump | | | | |

* EXC300M only

Figure 9 - Schematic diagram of EXC300 & EXC300M Controller electrical connections

3.4 Connect the electrical supply

WARNING

High voltages exist in the Controller when it is operating. Ensure that the Controller is earthed (grounded) and observe all appropriate safety precautions for the safe installation and handling of electrical equipment. If you do not, there will be a danger of injury or death to people by electric shock.

Note: If you will use an EXC300 or EXC300M Controller in a commercial or residential environment, you must fit the in-line filter supplied to the electrical supply connector on the Controller, then fit the connector on the electrical supply cable to the filter.

1. Connect the wires at one end of the electrical supply cable to a suitably rated and fused electrical supply; if required, connect the wires to a suitably rated plug. Connect the wires as follows:
 - Connect the green/yellow wire to earth (ground).
 - Connect the brown wire to the live electrical supply.
 - Connect the blue wire to the neutral electrical supply.
2. On EXC120, EXC300 and EXC300M Controllers, ensure the electrical supply isolator on the rear panel is in the off position.
3. Fit the connector on the other end of the electrical supply cable to the electrical supply connector on the rear of the Controller (see Figures 3 to 5).

3.5 Connect additional earth (ground) bonding (if required)

Protective earthing (grounding) for electrical safety of the EXC Controller, EXT pump and accessories is provided by the electrical supply cables and connectors and the pump-to-controller cable. However, additional earth (ground) bonding may be required to improve the reliability of the system by reducing any effects of RFI (radio frequency interference), particularly if the vacuum system is prone to high voltage discharges or other radio frequency emissions.

Use good EMC (electromagnetic compatibility) practices and take note of the following EMC earthing (grounding) guidelines to reduce the susceptibility of the system to RFI:

- Connect the Controller, the EXT pump and the vacuum chamber to a common earth (ground) point on the pumping system; this star earth (ground) is typically in the electrical power distribution box.
- Clamp the Controller earthing (grounding) terminal between the two lock-nuts provided on the earth (ground) stud on the rear panel of the Controller.
- Use suitable heavy duty cable or braid to ensure a low impedance bond to the earth (ground) point (typically less than 0.1Ω for each leg of the star).
- Use screened cable for all wiring to the logic interface connector. (The TAV5 vent-valve and the ACX Air Cooler accessories are provided with screened cable.) Connect each screen to the Controller earth (ground) stud to ensure that they are properly earthed (grounded).

3.6 Connect the EXT pump

Use a pump-to-controller cable (not supplied) to connect the Controller to the EXT pump. Fit the connectors on the ends of the cable to the appropriate mating-halves on the Controller and on the EXT pump. The connectors are polarised so you cannot fit a connector in the wrong orientation and different connector types are used on the Controller and on the EXT pump, so you cannot fit the cables the wrong way round.

3.7 Connect the backing pump (EXC120/300/300M only)

WARNING

Fit an earth (ground) wire to the backing pump relay electrical connector. If you do not, the case of the Controller may become live if there is a wiring fault.

Note: To control a backing pump with the EXC120E, use the 24 V d.c. vent-valve electrical supply on the logic interface to operate the pump through a suitable relay or contactor. This configuration will provide identical control logic to that for the backing pump relay on the other Controllers.

The single-pole backing pump relay in the Controller provides a switching signal to control the backing pump electrical supply; it does not provide a backing pump electrical supply. You can use the backing pump relay to control the backing pump in one of two ways:

- Directly, as shown in Figure 10
- Through a contactor, as shown in Figure 11.

Use a suitably rated three-core cable to connect the backing pump to the Controller. If you use an external contactor, ensure that the contactor is suitably rated for use in this way.

1. Connect the wires of your backing pump cable to the appropriate pins of the backing pump relay electrical connector (supplied). The pins of the connector are used as follows:

| Pin | Use |
|-----|-------------------|
| 1 | Live in |
| 2 | Switched live out |
| 3 | Earth (ground) |

2. Connect the other end of your cable to the backing pump and/or the electrical supply, as appropriate.

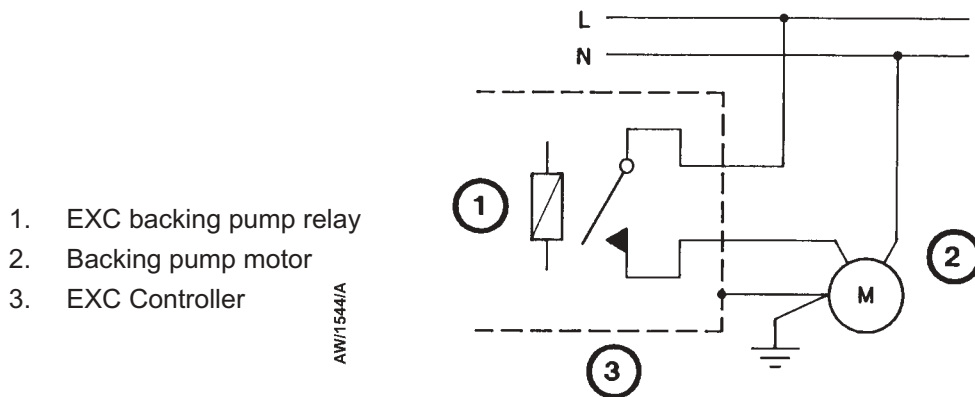

- 1. EXC backing pump relay
- 2. Backing pump motor
- 3. EXC Controller

AWI/1544/A

Figure 10 - Direct operation of the backing pump

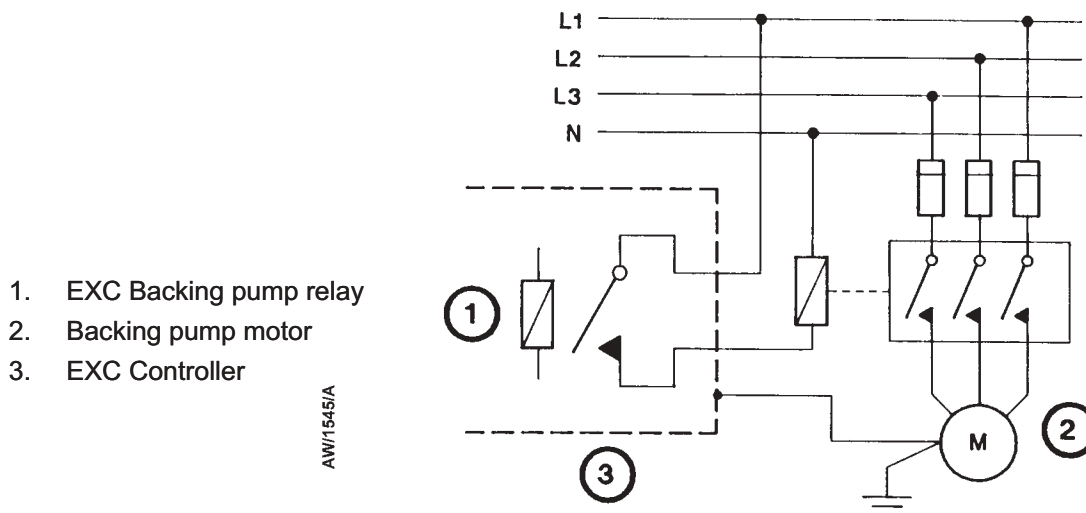

- 1. EXC Backing pump relay
- 2. Backing pump motor
- 3. EXC Controller

AWI/1545/A

Figure 11 - Operation of the backing pump through a contactor

3.8 Connect the bakeout band (EXC120/300/300M only)

If you have fitted a bakeout band to the EXT pump, insert a suitably rated fuse into the bakeout band fuse holder, then fit the connector on the bakeout band cable to the heater connector on the rear of the Controller (see Figures 3 and 5).

3.9 Connect an Active gauge

Use a BOC Edwards Active gauge cable (available as an accessory: see Section 7) to connect a BOC Edwards Active gauge to the Controller through the active gauge connector on the rear of the Controller (see Figures 3 to 5).

If you want to use the set-point facility on an Active Pirani Gauge or Active Thermocouple Gauge to operate the TMP Interlock, you must remove the link fitted to the TMP Interlock control input on the logic interface; that is:

- On EXC120 and EXC120E Controllers, remove the link between pins 12 and 13.
- On EXC300 and EXC300M Controllers, remove the link between pins 13 and 14.

If you want to use the Controller TMP Normal relay to enable an Active Inverted Magnetron Gauge, you must connect the TMP Normal relay isolated common line to the electrical supply 0 V line; that is:

- On EXC120 and EXC120E Controllers, link pins 4 and 7.
- On EXC300 and EXC300M Controllers, link pins 4 and 8.

3.10 Connect the logic interface to your equipment

CAUTION

Do not earth (ground) the logic interface 0 V line (pins 2 and 4). If you do, you will provide an earth (ground) return path for any electrical fault in the pump-motor and this could damage the Controller or your control equipment.

CAUTION

Do not connect voltages greater than 45 V to the logic interface. If you do, the Controller will not comply with the low voltage safety recommendations of IEC 1010.

Note: If your backing pump will take more than 30 minutes to reduce the pressure in the vacuum chamber to 1 mbar, we recommend that you use the TMP Interlock to delay the EXT pump Start until this pressure is reached.

The Controller is supplied with a mating-plug for the logic interface connector. As supplied, this mating-plug has three links fitted to close the TMP Interlock and SYS Interlock and to close the Start/Stop input. If you want to use the Controller for stand-alone operation, you **must** fit this mating-plug to the logic interface connector on the rear of the Controller (see Figures 3 to 5).

Use the appropriate pins on the mating-plug to connect your control equipment and accessories to the Controller, as described in the previous sections and as shown in Table 3 and Figures 8 and 9. Note that, depending on how you want to use the Controller, you may have to remove the factory fitted links from the mating-plug.

3.11 Adjust the Normal speed setpoint

Note: If you set the Normal speed setpoint to be more than 70% of full rotational speed, the TMP Normal relay will open when you select Standby. The Controller is supplied with the Normal speed setpoint adjusted to 80% of full rotational speed.

You can adjust the Normal speed setpoint (at which the TMP Normal relay will close: see Section 1.7.4) between 65 and 95% of full rotational speed.

To adjust the Normal speed setpoint, use a small screwdriver to turn the SET POINT potentiometer; an access hole is provided on the top cover of the Controller. Figure 12 detail A shows the approximate Normal speed setpoint settings for different potentiometer adjustments.

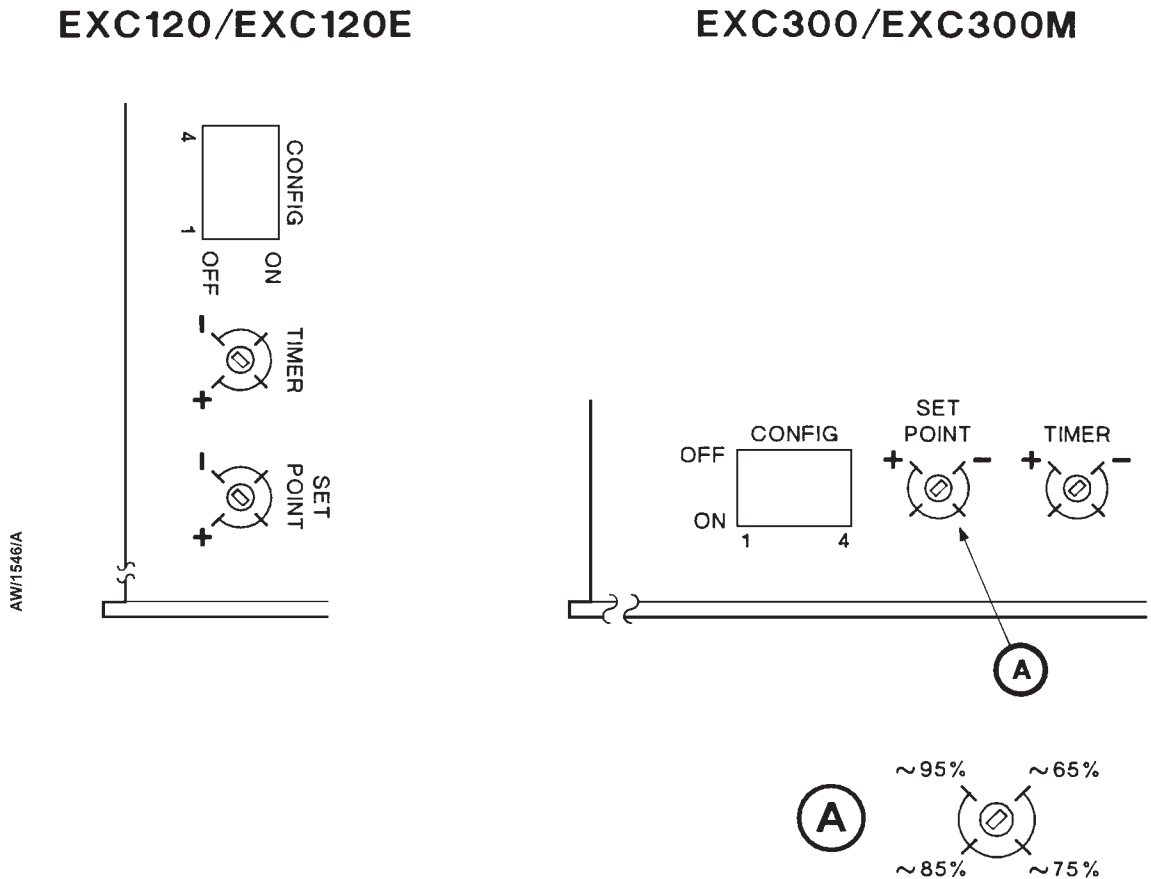

Figure 12 - Top cover of the Controller

3.12 Adjust the Internal Timer

The Internal Timer can be adjusted between approximately 1 and 30 minutes. The Controller is supplied with the Internal Timer adjusted to 8 minutes (see Section 1.9.2).

To adjust the Internal Timer, use a small screwdriver to turn the TIMER potentiometer; an access hole is provided on the top cover of the Controller (see Figure 12).

1. Turn the potentiometer fully anticlockwise; this position corresponds to the minimum time of approximately 1 minute.
2. Turn the potentiometer clockwise to set the required time; one full turn adds approximately two minutes to the set time. For example, seven full turns give a set delay time of approximately 15 minutes.

3.13 Configure the Controller

3.13.1 Introduction

The Controller has four DIP switches which can be used to configure the Controller for your application. The DIP switches are on the top of the Controller (the CONFIG switches shown in Figure 12). Set the DIP switches as described in the following sections.

3.13.2 Enable/disable the Internal Timer to monitor low pump speed

Note: If you pump a high gas load with the Internal Timer enabled (DIP switch 1 set to the off position), the EXT pump may stall before the Controller trips into Fail condition. Ensure that oil which backstreams from the backing pipeline will not adversely affect your process.

Disable the Internal Timer to provide the greatest protection against backstreaming when Fail condition occurs; as supplied, the Internal Timer is enabled.

Set DIP switch 1 to enable or disable the use of the Internal Timer when the pump rotational speed falls to below 50% of full rotational speed during operation (see Section 1.9.2):

- **Set DIP switch 1 to 'on' to disable the timer.** The Controller will then trip into Fail condition as soon as the pump rotational speed falls to below 50% of full rotational speed.
- **Set DIP switch 1 to 'off' to enable the timer.** The Internal Timer will then start as soon as the pump rotational speed falls to below 50% of full rotational speed. If the pump speed remains below 50% of full rotational speed after the preset time, the Controller will trip into Fail condition.

3.13.3 Vent options

Note: The Axial Emergency condition is only available on the EXC300M Controller. On other Controllers, the position of DIP switch 2 can be ignored.

DIP switches 2 to 4 are used to select the vent-valve control options (refer to Section 1.8). Select the required vent options as shown in Table 4.

Note however, that if the electrical supply to the Controller fails, the Controller will always switch off the electrical supply to the vent-valve when the EXT pump speed falls to below 50% of full speed (see Section 1.8.1).

| DIP switch positions | | | Vent option(s) selected |
|--------------------------------|---------------------|---------------------|--|
| 2 (Vent on Axial Emergency) | 3 (Vent on Fail) | 4 (Vent on Stop) | |
| Off | Off | Off | No optional vent selected: Vent when EXT pump speed falls to below 50% of full speed after Stop is selected |
| Off | Off | On | Vent on Stop |
| Off | On | Off | Vent on Fail and Vent when EXT pump speed falls to below 50% of full speed after Stop is selected |
| Off | On | On | Vent on Fail and Vent on Stop |
| On † | Off † | Off † | Vent on Axial Emergency* and Vent when EXT pump speed falls to below 50% of full speed after Stop is selected |
| On | Off | On | Vent on Axial Emergency* and Vent on Stop |
| On | On | Off | Vent on Axial Emergency* and Vent on Fail and Vent when EXT pump speed falls to below 50% of full speed after Stop is selected |
| On | On | On | Vent on Axial Emergency* and Vent on Fail and Vent on Stop |

* Only available on the EXC300M Controller.

† Factory setting

Table 4 - Selection of vent-valve control options

4 OPERATION

4.1 Start-up

Note: If you wish, you can start the backing pump and the EXT pump at the same time; the EXT pump will not be damaged and can operate as an effective baffle. However, if the system pressure remains too high for the EXT pump to reach 50% of full rotational speed in the preset time (set by the Internal Timer), the Controller will trip into Fail condition: refer to Section 3.12 for adjustment of the Internal Timer.

When Start is selected, if all Interlocks are closed, the Controller will switch on the electrical supply to the EXT pump and the pump rotor will start to accelerate.

Use the following procedure to start up your system. This procedure assumes that you will manually operate the vent-valve and the backing pump, however you can configure all EXC Controllers to automatically operate the vent-valve and you can configure the EXC120, EXC300 and EXC300M Controllers to automatically operate the backing pump (refer to Sections 1.8 and 3.13.3).

1. On EXC120, EXC300 and EXC300M Controllers, switch on the electrical supply isolator on the rear of the Controller (see Figures 3 and 5).
2. Close the vent-valve (if fitted).
3. Start the backing pump.
4. Start the EXT pump:
 - On the EXC120, EXC300 and EXC300M Controllers, press the Start button on the front panel of the Controller (Figures 1 and 2, item 4) and (if you have connected your equipment to the logic interface) close the Start/Stop input on the logic interface (see Section 1.7.3).
 - On the EXC120E Controller, close the Start/Stop input on the logic interface (see Section 1.7.3).

4.2 Standby

You can select Standby in one of two ways:

- On the EXC120, EXC300 and EXC300M Controllers, select the Standby button on the front panel of the Controller (Figures 1 and 2, item 3).
- Use your control equipment to close the Standby input on the logic interface (that is, ensure that the appropriate pins are linked: see Section 1.7 and Figures 8 and 9).

On the EXC120, EXC300 and EXC300M Controllers, the LED on the Standby button will go on when the Standby mode is selected (either by the button or the logic interface).

If you select Standby when the pump is operating, the speed of the pump will be reduced to the Standby speed. If you select Standby before you switch the pump on, the pump will run up to Standby speed, not up to full speed.

4.3 Bakeout band control (EXC120/300/300M only)

Note: As described in Section 3.8, you must insert a suitably rated fuse into the bakeout band fuse holder before you can use a bakeout band.

Press the Heater switch on the front panel of the Controller (Figures 1 and 2, item 2) to select the bakeout band on.

The Controller will switch on the electrical supply to the bakeout band when the EXT pump speed has reached the Normal speed setpoint. The electrical supply to the bakeout band will switch off if the pump speed drops to below the Normal speed setpoint, if the Controller is switched off, or if the Controller trips into Fail condition or Axial Emergency condition.

The LED on the Heater switch is on when the electrical supply to the bakeout band is on.

4.4 Operation with high inlet pressure

If the EXT pump inlet pressure rises, the power supplied by the Controller to the pump-motor will increase to counteract the gas frictional load. The pump rotational speed will remain constant until the Controller peak power level is reached; beyond this power level, the speed of the pump will start to reduce.

If the pump speed falls to below 50% of its full rotational speed, the Controller may trip into Fail condition, depending on how you configured the Controller (see Sections 1.8, 1.9 and 3.13).

Refer to the EXT pump instruction manual for the maximum allowable inlet pressure.

4.5 Operation with high pump temperature

Temperature sensors in the Controller and the EXT pump are monitored by the Controller. If the Controller detects that the pump temperature is too high, the power supplied to the pump-motor is reduced; the pump may not therefore be able to maintain full rotational speed if it is too hot.

If the pump speed falls to below 50% of its full rotational speed, the Controller may trip into Fail condition, depending on how you configured the Controller (see Sections 1.8, 1.9 and 3.13).

Refer to the EXT pump instruction manual for the pump operating temperature ranges.

4.6 The hours counter (EXC300 only)

The EXC300 Controller has an hours counter (see Figure 13) which shows the number of hours that the Controller has operated an EXT pump.

The hours counter has a 7-digit display (with no decimal point), on which the left-hand 5 digits (2) show the whole numbers of hours and the right-hand two digits (3) show the tenths and hundredths of hours. For example, if the hours counter shows 0010375", this indicates that the EXT pump has been operating for 103 hours and 45 minutes.

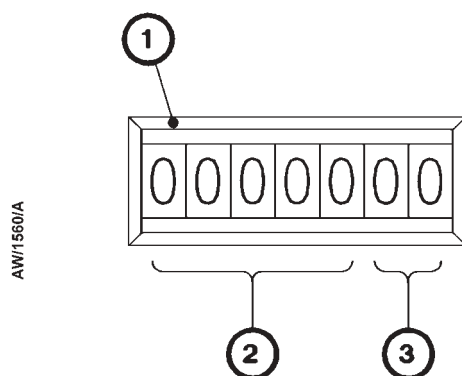

Figure 13 - Hours counter (EXC300 only)

4.7 Normal shutdown

Use the following procedure to shut down your system. This procedure assumes that you will manually operate the vent-valve and the backing pump, however you can configure all EXC Controllers to automatically operate the vent-valve and you can configure the EXC120, EXC300 and EXC300M Controllers to automatically operate the backing pump (refer to Section 3.13).

1. Select Stop:
 - On the EXC120, EXC300 and EXC300M Controllers, press the Start/Stop button on the front panel of the Controller (Figures 1 and 2, item 4) or open the Start/Stop input on the logic interface connector (see Section 1.7.3).
 - On the EXC120E Controller, open the Start/Stop input on the logic interface connector (see Section 1.7.3).
2. Open the vent-valve before the EXT pump speed is below 50% of full rotational speed.
3. Switch off the backing pump.

4.8 Automatic shutdown after Fail condition

WARNING

If Start is selected, the Controller will automatically restart the EXT pump when the electrical supply is restored after an electrical supply failure. Ensure that people cannot be injured by the rotating rotor blades of the EXT pump.

The EXC120, EXC120E and EXC300 Controllers will automatically switch off the electrical supply to the EXT pump if the Controller trips into Fail condition (see Section 1.9), though the EXC300M Controller will continue to provide an electrical supply for the electromagnetic bearings of the EXT250M pump.

If the SYS Interlock opens (see Section 1.7.3), the Controller will automatically open the vent-valve and (on the EXC120, EXC300 and EXC300M Controllers) will automatically open the backing pump relay. The operation of the vent-valve and backing pump in all other Fail conditions depends on how you have configured the Controller: refer to section 3.13.

4.9 Reset the Controller after Fail condition

Note: You can only reset the EXC300M Controller after an Axial Emergency condition if the EXT pump speed is below 10% of full rotational speed.

To reset a Fail condition, press the Start/Stop button (Figures 1 and 2, item 4) to select Stop, then press it again, or (if you have connected your equipment to the logic interface) open the Start/Stop input on the logic interface for a minimum time of 300 ms and then close the input.

4.10 Electrical supply failure

If the electrical supply to the Controller fails when the EXT pump is rotating:

- The backing pump shuts down (due to the electrical supply failure).
- The motor of the EXT pump is used as a generator and the electrical supply for the vent-valve is maintained until the pump speed falls to 50% of full rotational speed, then the electrical supply for the vent-valve is switched off.
- EXC120, EXC120E and EXC300 Controllers will then shut down. On the EXC300M Controller, the motor of the EXT pump will continue to act as a generator until pump speed is reduced to approximately 10% of full rotational speed. The EXC300M Controller then shuts down and the EXT250M pump rotor drops onto its safety bearings.

5 Maintenance

5.1 Safety

WARNING

Obey the safety instructions given below and take note of appropriate precautions. If you do not, you can cause injury to people and damage to equipment.

- A suitably trained and supervised technician must perform maintenance work.
- Isolate the Controller and other components in the pumping system from the electrical supply so that they can not be operated accidentally.
- Dispose of components safely (see Section 6.2).

5.2 Replace a fuse

5.2.1 Introduction

If a fuse fails immediately after you have replaced it, determine the cause of the failure and rectify the fault before you use the Controller.

5.2.2 Replace the electrical supply fuse

The electrical supply fuse is an integral part of the electrical supply socket on the rear of the Controller (see Figures 3 to 5).

1. Remove the electrical supply plug.
2. Remove the fuse holder, remove and discard the failed fuse.
3. Insert a new fuse of the correct rating (refer to Section 2.7) and refit the fuse holder.

5.3.3 Replace the bakeout band fuse (EXC120/300/300M only)

The bakeout band fuse is on the rear of the Controller (see Figures 3 and 5).

1. Turn and pull out the fuse holder.
2. Remove and discard the failed fuse and replace with a new fuse of the correct rating (refer to Section 2.7).
3. Refit the fuse holder.

5.4 Fault finding

If the Controller shuts down because of Fail condition, refer to the appropriate sections of this manual to determine the cause of the Fail. If necessary, refer to the appropriate fault finding section of the instruction manual supplied with the EXT pump.

5.5 Clean the Controller

If necessary, use a soft dry cloth to clean the exterior of the Controller.

If you need to clean the interior of the Controller, we recommend that you return the Controller to your supplier or your nearest BOC Edwards Service Centre.

6 STORAGE AND DISPOSAL

6.1 Storage

Fit protective covers over the electrical connections and store the Controller in clean dry conditions until required.

When required for use, prepare and install the Controller as described in Section 3 of this manual.

6.2 Disposal

WARNING

Do not incinerate the Controller. If you do, you may cause injury to people.

Dispose of the Controller and any components safely in accordance with all local and national safety and environmental requirements.

Do not incinerate the Controller. If the Controller is heated to very high temperatures, dangerous gases may be emitted and internal components may explode.

7 SPARES AND ACCESSORIES

7.1 Introduction

BOC Edwards products, spares and accessories are available from BOC Edwards companies in Belgium, Brazil, Canada, China, France, Germany, Israel, Italy, Japan, Korea, Singapore, Switzerland, United Kingdom, U.S.A and a world-wide network of distributors. The majority of these centres employ Service Engineers who have undergone comprehensive BOC Edwards training courses.

Order spare parts and accessories from your nearest BOC Edwards company or distributor. When you order, please state for each part required:

- Model and Item Number of your equipment
- Serial number (if any)
- Item Number and description of the part.

7.2 Spares

| Spare | Item Number |
|--|--------------------|
| Electrical supply cable (2 m length, unterminated) | D385-01-102 |
| Logic interface connector | |
| EXC120/120E Controllers | D396-16-382 |
| EXC300/300M Controllers | D396-15-062 |
| Backing pump relay connector * | D396-14-026 |

* Not applicable to the EXC120E Controller

7.3 Accessories

7.3.1 Pump-to-controller cable

A pump-to-controller cable must be used with each pump. It is not supplied with the EXT pump or the EXC Controller. The following cables are available:

| Cable | Item Number | |
|-------------------------------|---------------------------------|-------------|
| | EXT70/250/351/501EXT250M | |
| Pump-to-controller cable, 1 m | D396-18-010 | D396-19-010 |
| Pump-to-controller cable, 3 m | D396-18-030 | D396-19-030 |
| Pump-to-controller cable, 5 m | D396-18-050 | D396-19-050 |

7.3.2 BX bakeout band (EXC120/300/300M only)

A BX bakeout band accelerates the degassing of the pump to enable it to achieve lower pressures. It may also be used to protect the pump from condensation of contaminants. The bakeout bands are available in 110-120 V or 220-240 V versions and may be powered from a connector on the rear panel on the EXC120, EXC300 and EXC300M Controllers.

| Bakeout band | Voltage | Item Number |
|---------------------|----------------|--------------------|
| BX70 | 110 V | B580-52-040 |
| BX70 | 240 V | B580-52-060 |
| BX250 | 110 V | B580-52-041 |
| BX250 | 240 V | B580-52-061 |
| BX351 | 110 V | B580-52-042 |
| BX351 | 240 V | B580-52-062 |
| BX501 | 110 V | B580-52-044 |
| BX501 | 240 V | B580-52-064 |

7.3.3 TAV vent-valve

A solenoid-operated vent-valve is available for system venting. The valve is 24 V d.c. 2 W, normally-open, and can be operated automatically from the EXC Controller. The solenoid-valve is fitted in place of the manual vent-valve, or alternatively can be fitted with an adaptor (supplied with the valve) and used with any suitable NW10 flanged port on your vacuum system.

| Product | Item Number |
|-----------------|--------------------|
| TAV5 vent-valve | B580-66-010 |

7.3.4 ACX air-cooler

An ACX air-cooler can be fitted to the EXT pump and can be operated automatically from the EXC120, EXC300 and EXC300M Controllers. However, please refer to Section 3 of the instruction manual for the EXT pump to check the suitability of air cooling in a particular application.

| Air-cooler | Item Number |
|-------------------|--------------------|
| ACX70 | B580-53-050 |
| ACX250 | B580-53-150 |
| ACX350/500 | B580-53-200 |

7.3.5 Active vacuum gauges

A number of Active vacuum gauges which can interface directly to the EXC Controllers are available. The following are examples of suitable gauges and accessories:

| Description | Item Number |
|--|--------------------|
| APG-M-NW16 Active Pirani Gauge | D021-71-000 |
| APG-L-NW16 Active Pirani Gauge | D021-73-000 |
| AIM-S-NW25 Active Inverted Magnetron Gauge | D145-45-000 |
| ATC-E Active Thermocouple Gauge | D351-08-000 |
| ATC-D $\frac{1}{8}$ inch NPT Thermocouple Gauge Tube | D351-12-000 |
| ATC-M $\frac{1}{8}$ inch NPT Thermocouple Gauge Tube | D351-13-000 |
| Active Gauge Cable, 0.5 m long | D400-01-005 |
| Active Gauge Cable, 1 m long | D400-01-010 |
| Active Gauge Cable, 3 m long | D400-01-030 |

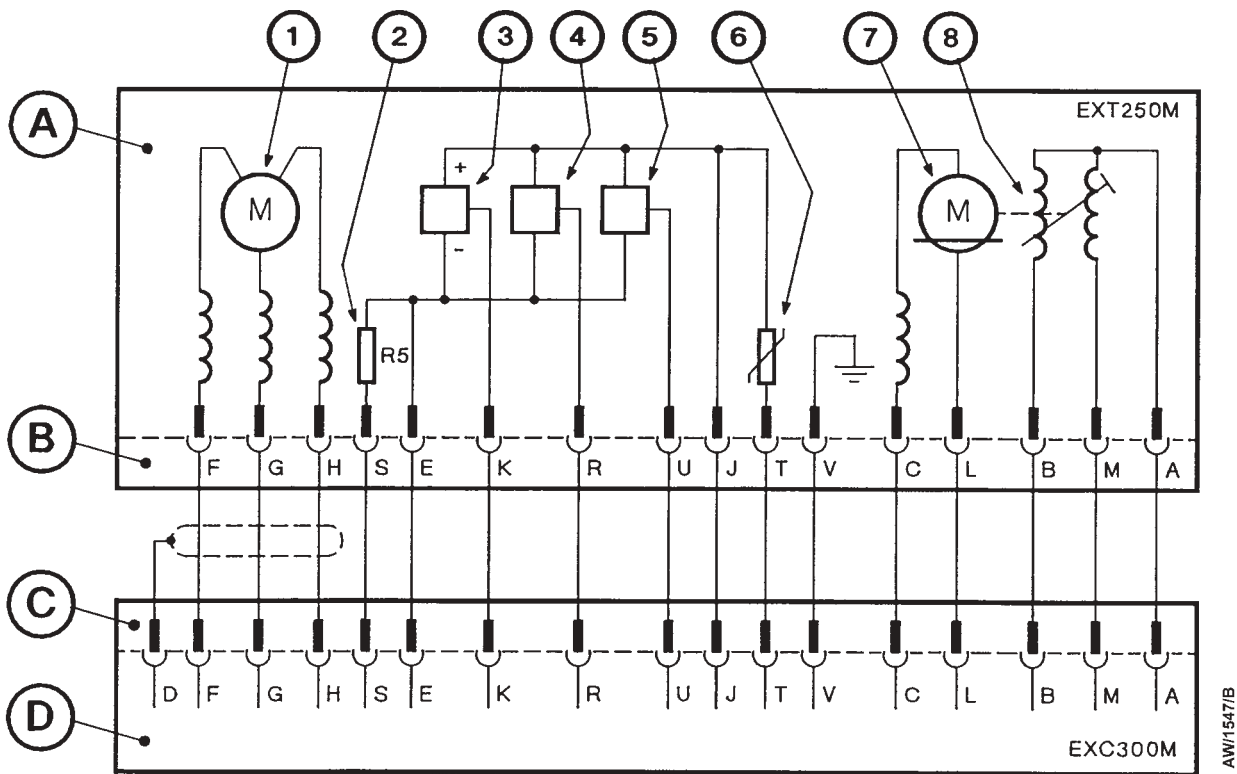

- | | |
|---|--|
| <p>A EXT pump</p> <p>B EXT connector on cable</p> <p>C EXC connector on cable</p> <p>D EXC Controller</p> | <p>1. DC motor</p> <p>2. Speed set resistor</p> <p>3. Hall effect device 1</p> <p>4. Hall effect device 2</p> <p>5. Hall effect device 3</p> <p>6. Pump temperature sensor</p> <p>7. Magnetic bearing stator</p> <p>8. Position sensor</p> |
|---|--|

Figure 15 - EXC300M Controller to EXT pump connections

AW1574/A

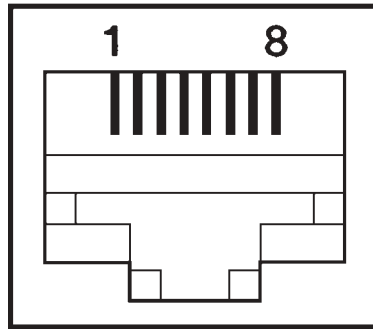

Figure 16 - Active Gauge connector

| Pin | Signal |
|-----|---|
| 1 | Power supply +24 V d.c. |
| 2 | Power supply 0 V d.c. |
| 3 | Not used |
| 4 | Gauge identification signal |
| 5 | Not used |
| 6 | Controller enable (equivalent to TMP Interlock) |
| 7 | Gauge enable (equivalent to TMP Normal) |
| 8 | Not used |

Table 5 - Active Gauge connector pins

(This page deliberately left blank)