

Instruction Manual

E1M40, E1M80, E2M40 and E2M80 E2M40S and E2M80S Rotary Vacuum Pumps

www.idealvac.com

Ideal
vacuum products
(505)872-0037



Description	Item Number	Description	Item Number
E1M40, 240 V, 50 Hz, single-phase	A344-01-960	E1M80, 208 V, 50 Hz/208-230 V, 60 Hz/460 V, 60 Hz, three-phase	A345-02-982
E1M40, 220-240/380-415 V, 50 Hz, three-phase	A344-01-935	E2M80, 220-240/380-415 V, 50 Hz, three-phase	A365-01-935
E1M40, 208 V, 50 Hz/208-230 V, 60 Hz/460 V, 60 Hz, three-phase	A344-02-982	E2M80, 208 V, 60 Hz/208-230 V, 60 Hz/460 V, 60 Hz, three-phase	A365-02-982
E2M40, 240 V, 50 Hz, single-phase	A364-01-960	E2M40S, 220-240/380-415 V, 50 Hz, three-phase	A364-13-935
E2M40, 220-240/380-415 V, 50 Hz, three-phase	A364-01-935	E2M40S, 208 V, 50 Hz/208-230 V, 60 Hz/460 V, 60 Hz, three-phase	A364-13-982
E2M40, 208 V, 50 Hz/208-230 V, 60 Hz/460 V, 60 Hz, three-phase	A364-02-982	E2M80S, 208 V, 50 Hz/208-230 V, 60 Hz/460 V, 60 Hz, three-phase	A365-13-982
E1M80, 220-240/380-415 V, 50 Hz, three-phase	A345-01-935		





Declaration of Conformity

We, BOC Edwards,
Manor Royal,
Crawley,
West Sussex RH10 2LW, UK

declare under our sole responsibility that the product(s)

E1M40, E2M40, E1M80 and E2M80 Rotary Vacuum Pumps

A344-01-935	A344-01-960	A344-02-982	A344-11-935
A344-12-982	A345-01-935	A345-02-982	A364-01-935
A364-01-960	A364-02-982	A364-11-935	A364-12-982
A364-13-935	A364-13-982	A364-21-935	A364-22-982
A364-40-935	A365-01-935	A365-02-982	A365-11-935
A365-12-982	A365-13-935	A365-13-982	

to which this declaration relates is in conformity with the following standard(s)
or other normative document(s)

EN ISO 12100-2: 2003 Safety of Machinery – Basic Concepts, General Principles for Design.

IEC 34 Parts 1, 5, 8†, 11*: 1991 Central Requirements for Rotating Electrical Machines.

† 3-phase pumps only.

* 1-phase pumps only.

following the provisions of

73/023/EEC
89/336/EEC
98/37/EC

Low Voltage Directive.
Electromagnetic Compatibility Directive.
Machinery Safety Directive.

Dr. J. D. Watson, Director of Technology,
Vacuum Equipment and Exhaust Management Product Divisions

8 December 2004 BHOUREHAM

Date and Place

This product has been manufactured under a quality system registered to ISO9001

Contents

Section	Page
1	Introduction 1
1.1	Scope and definitions 1
1.2	Description 3
1.3	Gas-ballast 3
2	Technical data 5
2.1	Operating and storage conditions 5
2.2	Performance 5
2.3	Mechanical data 8
2.4	Electrical data: single-phase motor 8
2.5	Electrical data: three-phase motors 8
2.6	Lubrication data 9
3	Installation 11
3.1	Safety 11
3.2	System design considerations 11
3.3	Unpack and inspect 12
3.4	Locate the pump 13
3.5	Fill the pump with oil 13
3.5.1	Recommended pump oils 13
3.5.2	Filling procedure 14
3.6	Electrical installation: single-phase motor 14
3.7	Electrical installation: three-phase motors 15
3.7.1	Connect the pump to your electrical supply 15
3.7.2	Check the direction of rotation 17
3.8	Connect the pump inlet to your system 17
3.8.1	General information 17
3.8.2	Connect to ISO40 fittings 18
3.8.3	Connect to NW40 fittings 18
3.9	Connect the pump outlet to your system 19
3.10	Gas-ballast inlet connection 19
3.11	Leak-test the system 19
4	Operation 21
4.1	Gas-ballast control 21
4.2	Start-up procedure 21
4.3	To achieve ultimate vacuum 22
4.4	To pump condensable vapours 22
4.5	To decontaminate the oil 22
4.6	Unattended operation 23
4.7	Shut-down 23

5	Maintenance	25
5.1	Safety	25
5.2	Maintenance plan	26
5.3	Check the oil-level	27
5.4	Replace the oil	27
5.5	Replace the fine oil-filter	28
5.6	Replace the gas-ballast filter	29
5.7	Inspect and clean the inlet-filter	30
5.8	Clean the oil-level sight-glass	31
5.9	Clean the motor fan-cover	32
5.10	Clean and overhaul the pump	32
5.11	Test the motor condition	32
5.12	Fit new blades	32
5.13	Basic fault-finding	33
5.13.1	The pump has failed to start	33
5.13.2	The pump fails to achieve its specified performance	33
5.13.3	The pump is noisy	34
5.13.4	The pump is too hot	34
5.13.5	The vacuum is not fully maintained after the pump is switched off	34
5.13.6	The pumping speed is poor	34
5.13.7	There is an external oil leak	35
6	Storage and disposal	37
6.1	Storage	37
6.2	Disposal	37
7	Spares and accessories	39
7.1	Introduction	39
7.2	Service	39
7.3	Spares	40
7.4	Accessories	40
7.4.1	Inlet dust-filter	40
7.4.2	Inlet catchpot	41
7.4.3	High-capacity inlet dust-filter	41
7.4.4	Inlet chemical-trap	41
7.4.5	Outlet catchpot	41
7.4.6	Outlet mist-filter (clean applications)	42
7.4.7	Outlet mist-filter (toxic applications)	42
7.4.8	External oil filter	42
7.4.9	Oil-level monitor	43
7.4.10	Solenoid-operated gas-ballast control valve	43
7.4.11	Vibration isolators	44

Appendix A	E2M40S and E2M80S (Superpumps).....	45
A1	Introduction	45
A1.1	Scope of this appendix	45
A1.2	Description	45
A1.2.1	Construction	45
A1.2.2	Purpose of dry nitrogen gas-ballast	45
A2	Technical data	47
A2.1	Performance	47
A2.2	Lubrication data	47
A2.3	Electrical data: three-phase motors	48
A3	Installation	49
A3.1	Pump external fittings, connections and controls	49
A3.2	Fill the pump with oil	51
A4	Operation	53
A4.1	Start-up	54
A4.2	Shut-down	55
A5	Spares	57

For return of equipment, complete the HS Forms at the end of this manual.

Illustrations

Figure	Page	
1	The Rotary Vacuum Pump (E1M40 shown)	2
2	Dimensions E1M40 and E2M40 (mm)	6
3	Dimensions E1M80 and E2M80 (mm)	7
4	Electrical supply connection, single-phase motor, 240 V 50 Hz	14
5	Electrical supply connection, three-phase motors, 220-240 V 50 Hz, 208-230 V 60 Hz, or 208 V 50 Hz ..	15
6	Electrical supply connection, three-phase motors, 380-415 V 50 Hz, or 460 V 60 Hz	16
7	Connect inlet to ISO40 fittings	18
8	Connect inlet to NW40 inlet fittings	18
9	Fine oil-filter and gas-ballast bearing-plate locations	28
10	Remove and replace inlet-filter	30
11	Oil-level sight-glass assembly	31
12	Accessories	44
A1	External oil-filtration unit tapping points	49
A2	External fittings, connections and controls	50
A3	Typical dry nitrogen gas circuit	54

Tables

Table		Page
1	Electrical data (single-phase motor)	8
2	Electrical data (three-phase motors)	9
3	Checklist	12
4	Maintenance plan	26
A1	Electrical data (three-phase motors)	48

Associated publications

Publication title	Publication number
Vacuum pump and vacuum system safety	P300-20-000
Vibration isolators	A248-01-880
MF mist filters and CP catchpots	A461-03-880
E1M40/80, E2M40/80 external oil filtration system adaptor kit	A540-00-880
EOF external oil filtration system	A540-01-880

Trademark credits

Fomblin® is a registered trademark of Ausimont SpA.

1 Introduction

1.1 Scope and definitions

This manual provides installation, operation and maintenance instructions for the Edwards E1M40, E1M80, E2M40, E2M80 Rotary Vacuum Pumps. You must use your pump as specified in this manual.

Read this manual before you install and operate your pump. Important safety information is highlighted as WARNING and CAUTION instructions; you must obey these instructions. The use of WARNINGS and CAUTIONS is defined below.



WARNING

Warnings are given where failure to observe the instruction could result in injury or death to people.

CAUTION

Cautions are given where failure to observe the instruction could result in damage to the equipment, associated equipment and process.

The units used throughout this manual conform to the SI international system of units of measurement.

The following warning symbols are on the pump:



Warning - refer to accompanying documentation.



Warning - risk of electric shock.



Warning - hot surfaces.

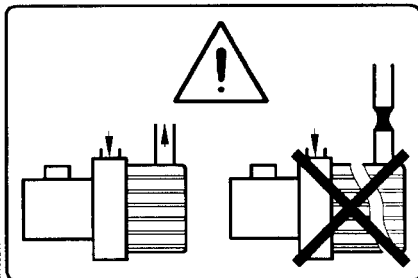

Warning - do not block the pump outlet.

Figure 1 - The Rotary Vacuum Pump (E1M40 shown)

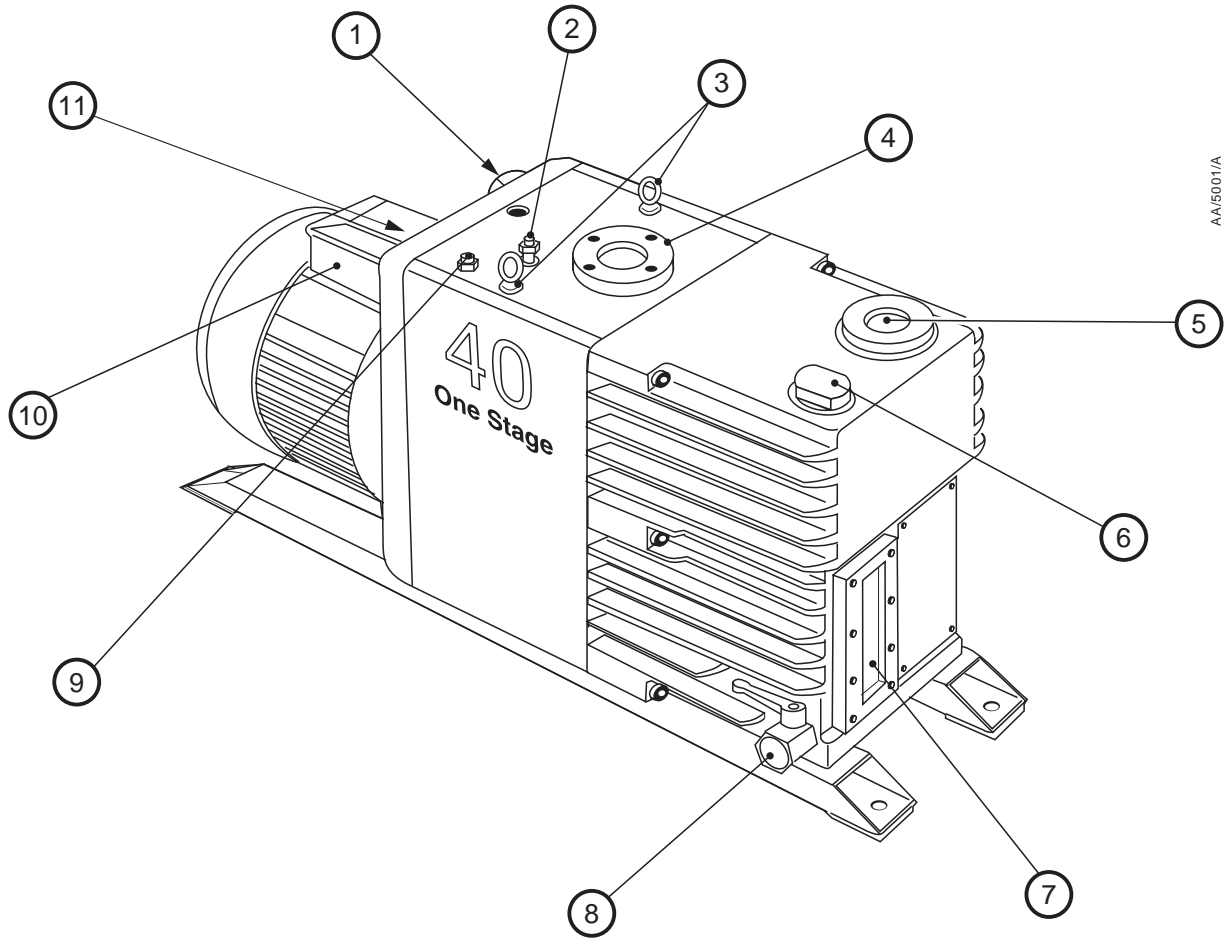

- | | |
|--|---|
| 1. Disposable oil-filter | 7. Oil-level sight-glass |
| 2. Oil return, from external oil mist filter | 8. Oil drain-tap |
| 3. Lifting-eyes | 9. Connection for oil pressure gauge accessory |
| 4. Inlet-port | 10. Motor terminal-box |
| 5. Outlet-port | 11. Gas-ballast control inlet and gas-ballast control |
| 6. Oil filler-plug | |

1.2 Description

Note: The following section refers to [Figure 1](#) unless stated otherwise.

The E1M40, E1M80, E2M40 and E2M80 pumps are single or two-stage oil-sealed, high-vacuum pumps designed for reliable, long-term operation in both laboratory and industrial environments. A single-phase motor or a four-pole three-phase motor provides direct-drive through a flexible coupling. The pumps are free-standing mounted on steel runners.

The E1M (single-stage) pumps have a high-vacuum rotor and stator assembly with integral sliding-vane oil-pump. The E2M (two-stage) pumps have an additional low-vacuum rotor and stator assembly.

Lubrication is provided by a sliding vane oil pump. Oil is drawn into the pump through a wire mesh strainer. The oil is pumped to a spring-loaded distributor valve. The distributor valve directs a lightly-pressurised supply of oil to the main vacuum-pump and by-passes the excess back to the oil reservoir. Some of the excess oil is re-directed through a large area, fine-pore filter and some through a relief-valve. When you switch off an E2M40 or E2M80 pump with the gas ballast control closed, the spring loaded distributor valve provides oil and air suckback protection. The distributor valve provides only oil suckback protection when you switch off an E1M40 or E1M80 pump. To obtain air suckback protection when you switch off an E1M40 or E1M80 pump, you must fit a solenoid operated gas-ballast control valve: refer to the information in [Section 1.3](#).

You can inspect the level and condition of oil in the oil box through an oil-level sight-glass (7). An oil filler-plug (6) is fitted at the top of the oil box. An oil drain-tap (8) is fitted at the bottom of the oil box.

The inlet-port flange (4) is compatible with ISO40 or NW40 fittings. The outlet-port (5) has an NW25 flange.

The gas-ballast control (11) allows you to control the introduction of gas-ballast when pumping high vapour loads. Refer to [Section 1.3](#) for more information about gas-ballast.

Refer to [Section 7](#) for details about vibration isolators and other recommended accessories.

1.3 Gas-ballast

To pump high vapour loads, gas-ballast is delivered into the pump to prevent condensation of the vapour carried by the pumped gases. This system reduces oil contamination and pump corrosion caused by condensed vapour from the pumped gases.

You can introduce air or an inert gas into the low vacuum stage of the pump through the gas-ballast inlet ([Figure 9](#), item 3). A filter/silencer is fitted in the gas-ballast system, to prevent the entry of dust into the pump and to improve silencing. You can control the gas-ballast either manually or remotely.

Note that the E1M40 and E1M80 pumps have a permanent air bleed through the gas-ballast inlet.

For manual control, use the gas-ballast control (Figure 9, item 4). The pumps are supplied with an open gas-ballast inlet (Figure 9, item 3). If you leave this inlet open to the atmosphere, then:

- With the gas-ballast control (Figure 9, item 4) open, when you switch the pump off, the pressure inside the pump will rise to atmospheric pressure
- With the gas-ballast control closed, when you switch the pump off:
 - E1M40 and E1M80: the pressure inside the pump will slowly rise to atmospheric pressure. (To maintain the vacuum inside the pump, fit a solenoid operated gas-ballast control valve.)
 - E2M40 and E2M80: the vacuum will be maintained inside the pump.

For remote control, fit a solenoid-operated gas-ballast control valve (available as an accessory from Edwards, refer to Section 7) to the gas-ballast inlet and open the gas-ballast control. Connect the gas-ballast valve to your control system so that the valve is closed when the pump is switched off and if the electrical supply to the pump is interrupted. Under these circumstances, when the pump is switched off, the vacuum will be maintained inside the pump.

For more information about the use of gas-ballast, refer to Sections 3.10 and 4.1.

2 Technical data

2.1 Operating and storage conditions

Ambient temperature range (operation)	12 to 40 °C
Normal surface temperature of the pump (at ultimate vacuum, ambient temperature of 20 °C)	50 to 70 °C
Maximum humidity (operation)	90% RH
Ambient temperature range (storage)	-30 to 70 °C

2.2 Performance

Note: Where total pressures are shown in the technical data tables, measurements were taken using an untrapped total pressure capacitance diaphragm gauge on a header, as specified by Pneurop standards.

		E1M40	E2M40	E1M80	E2M80
Maximum Displacement m ³ h ⁻¹					
50 Hz electrical supply		42.5	42.5	80	80
60 Hz electrical supply		50.5	50.5	96	96
Maximum Speed - Pneurop					
50 Hz electrical supply		37	37	74	74
60 Hz electrical supply		44	44	90	90
Motor rotational speed					
50 Hz electrical supply		1,410	1,410	1,420	1,420
60 Hz electrical supply		1,720	1,720	1,720	1,720
Ultimate vacuum					
without gas-ballast	mbar	5 x 10 ⁻²	1 x 10 ⁻⁴	5 x 10 ⁻²	1 x 10 ⁻⁴
(partial pressure)	Pa	(5)	(1 x 10 ⁻²)	(5)	(1 x 10 ⁻²)
without gas-ballast	mbar		1 x 10 ⁻³		1 x 10 ⁻³
(total pressure)	Pa		(1 x 10 ⁻¹)		(1 x 10 ⁻¹)
with full gas-ballast	mbar	4 x 10 ⁻¹	5 x 10 ⁻³	4 x 10 ⁻¹	5 x 10 ⁻³
(partial pressure)	Pa	(4 x 10 ¹)	(5 x 10 ⁻¹)	(4 x 10 ¹)	(5 x 10 ⁻¹)
Maximum permitted outlet pressure					
(at full pump throughput)	bar gauge	0.5	0.5	0.5	0.5
	Pa	(1.5 x 10 ⁵)	(1.5 x 10 ⁵)	(1.5 x 10 ⁵)	(1.5 x 10 ⁵)
Maximum water vapour inlet pressure	mbar	40	7	30	5
	Pa	(4 x 10 ³)	(7 x 10 ²)	(3 x 10 ³)	(5 x 10 ²)
Maximum water vapour pumping rate	kg h ⁻¹	1.1	0.2	1.7	0.3
Maximum gas-ballast flow	m ³ h ⁻¹	3.5	1.7	3.5	1.4

Figure 2 - Dimensions E1M40 and E2M40 (mm)

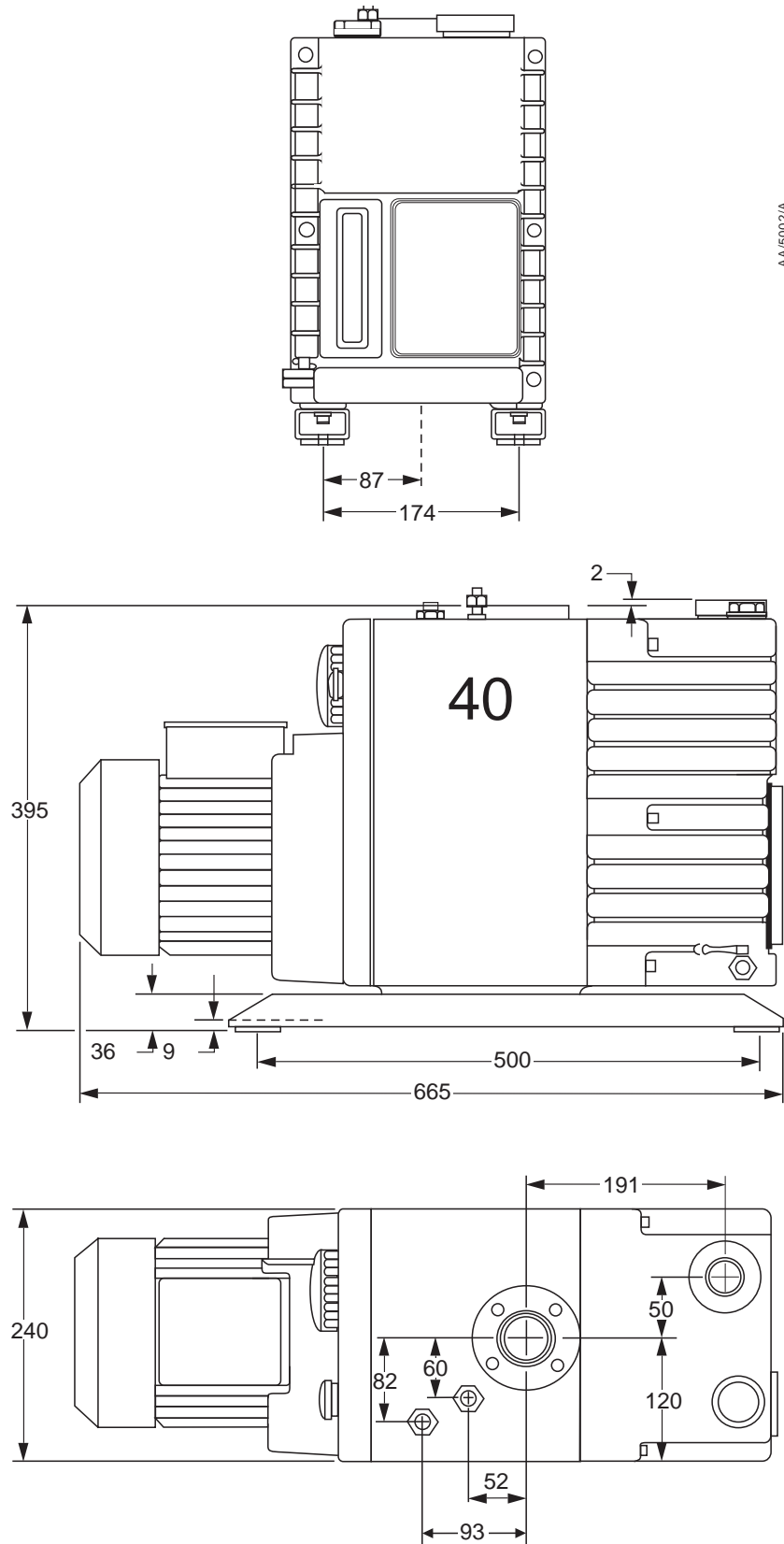
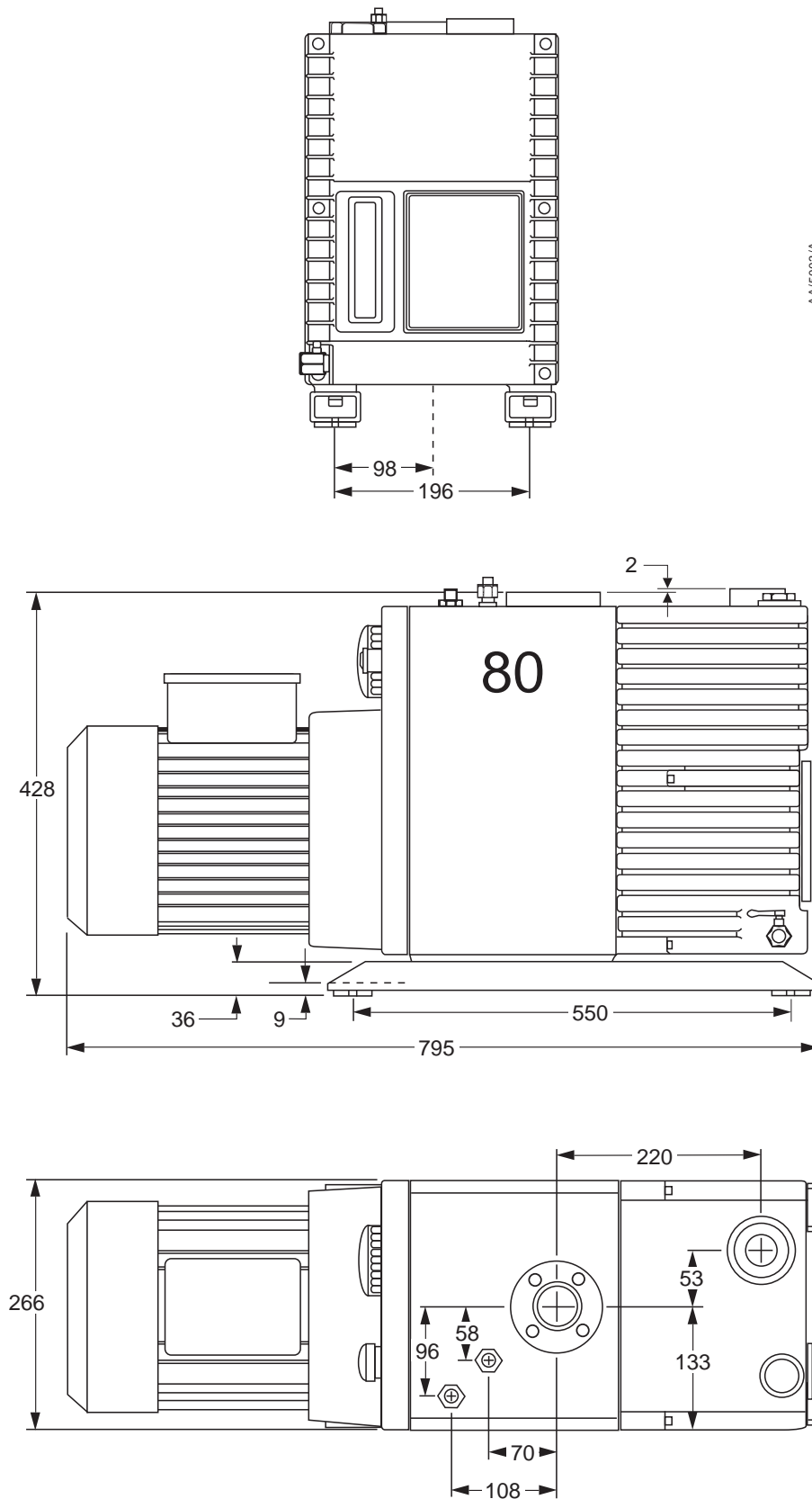

Figure 3 - Dimensions E1M80 and E2M80 (mm)



2.3 Mechanical data

Dimensions	See Figure 2 (E1M40 and E2M40 pumps) and Figure 3 (E1M80 and E2M80 pumps)
Degree of protection (IEC 34-5:1981)	IP55
Pump inlet-port	ISO40 or NW40
Pump outlet-port	25 mm flange, suitable for NW25 fittings

	E1M40	E2M40	E1M80	E2M80
Maximum mass (kg)	70.5	72	95	105
Noise level at 1 metre (dB(A))	65	65	70	70

2.4 Electrical data: single-phase motor

When you start a cold pump, the motor draws the start-up current shown in [Table 1](#) for less than one second. To prevent unnecessary fuse failure during start-up use a slow-blow fuse. Within five minutes, as the oil in the pump warms up, the start-up current reduces to the full-load current specified in [Table 1](#).

Table 1 - Electrical data (single-phase motor)

Pump	Nominal supply (V)	Frequency (Hz)	Power (kW)	Full-load current (A)	Start-up current (A)	Recommended fuse rating (A)	Electrical Supply Connection Figure
E1M40 E2M40	240	50	1.1	6.8	40	25	4

2.5 Electrical data: three-phase motors

Refer to the data in [Table 2](#). You can configure the dual voltage motors to operate with either the high range or low range electrical supply: refer to the diagram specified in [Table 2](#). Dual voltage motors are supplied preset to the highest of the selectable voltages.

When you start a cold pump, the motor draws the start-up current listed in [Table 2](#) for less than one second. Within five minutes, as the oil in the pump warms up, the current drawn slowly reduces to the full-load current specified in [Table 2](#).

When you restart a hot pump, the motor draws the start-up current specified in [Table 2](#) for up to 0.5 seconds. The current drawn then immediately falls to the full-load current value.

Table 2 - Electrical data (three-phase motors)

Pump	Nominal supply (V)	Frequency (Hz)	Power (kW)	Full load current (A)	Start-up current (A)	Recommended fuse rating (A)*	Electrical supply connection, Figure
E1M40 or E2M40	220-240	50	1.1	4.5	25	15	5
	380-415	50	1.1	2.6	14	10	6
E1M80 or E2M80	220-240	50	2.2	8.5	51	30	5
	380-415	50	2.2	4.9	29	20	6
E1M40 or E2M40	208	50	1.5	6.8	41	25	5
	208-230	60	1.5	6.5	39	25	5
	460	60	1.5	3.1	18.6	15	6
E1M80 or E2M80	208	50	3.0	12.4	71	40	5
	208-230	60	3.0	11.8	71	40	5
	460	60	3.0	5.6	34	20	6

* You may need to use a different fuse rating. Use the information supplied with your circuit breaker or starter to select the correct fuse rating.

2.6 Lubrication data

Note: An Edwards Health and Safety Data Sheet for the following oil is available on request.

Recommended oil*	Ultragrade 70			
	E1M40	E2M40	E1M80	E2M80
Oil capacity (litres)				
Maximum	4.6	4.07	7.0	6.3
Minimum	2.2	2.2	4.0	4.0

* To operate your pump when the ambient temperature is outside the limits specified in Section 2.1, or to optimise your pump performance when you pump condensable vapours, you may need to use a different oil.

This page has been intentionally left blank.

3 Installation

3.1 Safety

You must ensure that the pump is suitable for your application. If you have any doubt about the suitability of the pump for your application, refer to the Edwards guidelines on vacuum pump and vacuum system safety. (See Associated Publications at the end of the contents list).



WARNING

Obey the safety instructions given below and take note of appropriate precautions. If you do not, you may cause injury to people and damage to equipment.

Obey the safety instructions listed below when you install the pump, especially when you connect the pump into an existing system. Details of specific safety precautions are given at the appropriate point in the instructions.

- The installation of your pump must be performed by a suitably trained and supervised technician.
- Wear the appropriate safety-clothing when you come into contact with contaminated components.
- Vent and purge your vacuum system before you start installation work.
- Ensure that the installation technician is familiar with the safety procedures which relate to the pump-oil and the products handled by the pumping system. Take suitable precautions to avoid the inhalation of oil mist and excessive skin contact with pump-oil, as prolonged exposure can be harmful.
- Disconnect the other components in the pumping system from the electrical supply so that they cannot be operated accidentally.

3.2 System design considerations

Consider the following points when you design your pumping system:

- Use a suitable valve to isolate the pump from your vacuum system if you need to allow the pump to warm up before you pump condensable vapours or if you need to maintain vacuum when the pump is switched off.
- Avoid high levels of heat input to the pump from the process gases, otherwise the pump may overheat and seize.
- If you use the pump in a high ambient temperature and have a high gas throughput, the temperature of the pump-body may exceed 70°C. You must fit suitable guards to prevent contact with hot surfaces.
- Make sure that the exhaust pipeline cannot become blocked. If you have an exhaust-isolation valve, make sure that you cannot operate the pump with the valve closed.
- Provide for a purge of inert gas when you shut down the pumping system, to dilute dangerous gases to safe concentrations. A suitable solenoid operated gas-ballast control valve for introduction of purge-gas into the pump is available as an accessory (see [Section 7](#)).

3.3 Unpack and inspect



WARNING

Use suitable lifting equipment to move the pump. The mass of the pump is between 70.5 kg and 105 kg.

- Remove all packing materials, remove the pump from its packing-box, remove the protective covers from the inlet and outlet-ports and inspect the pump.
- If the pump is damaged, notify your supplier and the carrier in writing within three days; state the Item Number of the pump together with your order number and your supplier's invoice number.
- Retain all the packing materials for inspection.
- Do not use the pump if it is damaged.

Check that your package contains the following items:

Table 3 - Checklist

Qty.	Description	Check (✓)
1	E1M/E2M40 or 80 Rotary Vacuum Pump	<input type="checkbox"/>
Inlet fitting packs, containing:		
2	ISO40 Co-seal halves	<input type="checkbox"/>
1	NW40 Co-seal half (aluminium)	<input type="checkbox"/>
1	ISO40/NW40 seal (nitrile)	<input type="checkbox"/>
1	'C clamp	<input type="checkbox"/>
2	M8 x 25 hexagon head bolts	<input type="checkbox"/>
2	Washers	<input type="checkbox"/>
Outlet fitting pack, containing:		
1	'C clamp	<input type="checkbox"/>
1	Tube adaptor	<input type="checkbox"/>
1	Centering ring NW25	<input type="checkbox"/>
1	'O' ring	<input type="checkbox"/>
2	Fixing screws, M8 x 20 mm	<input type="checkbox"/>
2	Fixing washers, M8 shakeproof	<input type="checkbox"/>

If the pump is not to be used immediately, replace the protective covers. Store the pump in suitable conditions, as described in [Section 6.1](#).

3.4 Locate the pump



WARNING

Use suitable lifting equipment to move the pump. The mass of the pump is between 70.5 kg and 105 kg.

Attach your mechanical lifting equipment to the lifting eyes on the pump.

Provide a firm, level platform for the pump. Locate the pump so that the oil-level sight-glass is visible and the oil filler-plug, oil drain-tap, disposable oil-filter and gas-ballast control are accessible.

If your pump will be located inside an enclosure, make sure that there is adequate ventilation at both ends of the pump, so that the ambient temperature around the pump does not exceed 40°C. There must be a minimum space of 25 mm between the pump and the enclosure walls.

3.5 Fill the pump with oil

3.5.1 Recommended pump oils



WARNING

If you use a hydrocarbon oil in this pump, you must not use the pump to process oxygen in concentrations greater than 25% in volume. If you do, there is a risk of fire or explosion in the oil-box of the pump.

When the ambient temperature is 12°C or higher, we recommend that you use Edwards Ultragrade 70 oil. This tested and proven oil will give you the best performance, maintenance intervals and pump life. Otherwise, use another oil with the specification VG ISO 68.

If you pump oxygen or other dangerous gases and vapours, you must use a chemically inert and stable oil (such as perfluoropolyether). For information on pumping dangerous gases and vapours, refer to the Edwards guidelines on vacuum pump and vacuum system safety (see Associated Publications at the end of the contents list).

3.5.2 Filling procedure

Fill the pump with oil as described below. Refer to [Figure 1](#) for the item numbers in brackets.

1. Remove the oil filler-plug (6)
2. Pour oil into the pump until the oil-level just reaches the MAX mark on the bezel at the top of the sight-glass (7). If the oil-level goes above the MAX mark, open the oil drain-tap (8) and drain the excess oil from the pump. When the oil-level falls to the MAX mark close the oil drain-tap (8).
3. After a few minutes, recheck the oil-level. If the oil-level is now below the MAX mark, pour more oil into the pump.
4. Refit the oil filler-plug (6). Tighten the plug firmly by hand. Do not over-tighten.

3.6 Electrical installation: single-phase motor



WARNING

Ensure that the electrical installation of your pump-motor conforms with your local and national safety requirements. It must be connected to a suitably fused and protected electrical supply and a suitable earth point.

Note: *The pump will restart automatically when the electrical supply is restored after an interruption. If you do not want the pump to restart automatically, use electrical control equipment which must be reset manually.*

1. Remove the motor terminal-box cover ([Figure 1](#), item 10) and remove the 20 mm diameter plugs from the cable-entry hole that you will use for the electrical supply cable. Choose the most suitable hole for your application.
2. Fit a suitable cable-gland and nut to the entry hole. After the supply cable is fitted, the cable-gland must be a protective seal to the standard of IP44 in IEC 529 or better.
3. Pass the motor electrical supply cable through the cable-gland.
4. Connect the cables to the terminals as shown in [Figure 4](#).

Figure 4 - Electrical supply connection, single-phase motor, 240 V 50 Hz

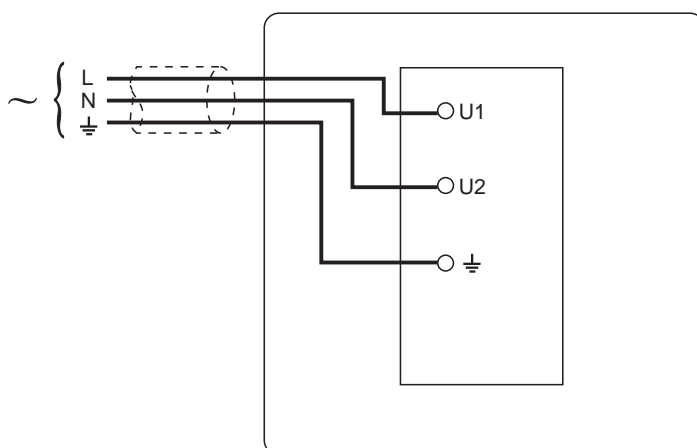

AA/5004/A

3.7 Electrical installation: three-phase motors

3.7.1 Connect the pump to your electrical supply



WARNING

Ensure that the electrical installation of your pump-motor conforms with your local and national safety requirements. It must be connected to a suitably fused and protected electrical supply and a suitable earth point.

CAUTION

If your pump-motor can be used with more than one voltage range, you must ensure that the motor is configured for your electrical supply voltage. If you do not, you may damage the motor.

Note: The pump will restart automatically when the electrical supply is restored after an interruption. If you do not want the pump to restart automatically, use electrical control equipment which must be reset manually.

Figure 5 - Electrical supply connection, three-phase motors, 220-240 V 50 Hz, 208-230 V 60 Hz, or 208 V 50 Hz

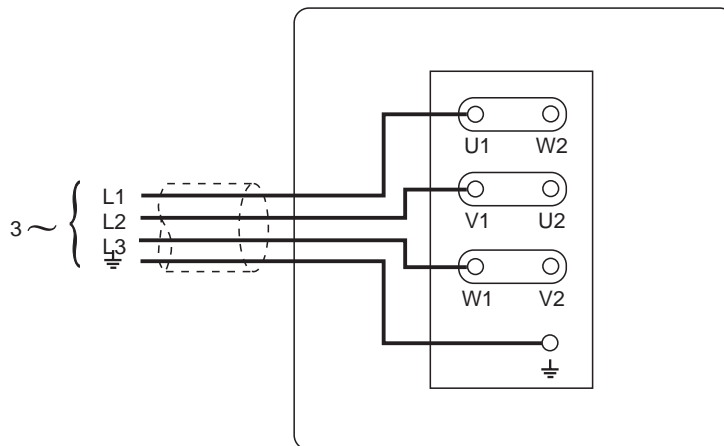

AA/5005/A

Figure 6 - Electrical supply connection, three-phase motors, 380-415 V 50 Hz, or 460 V 60 Hz

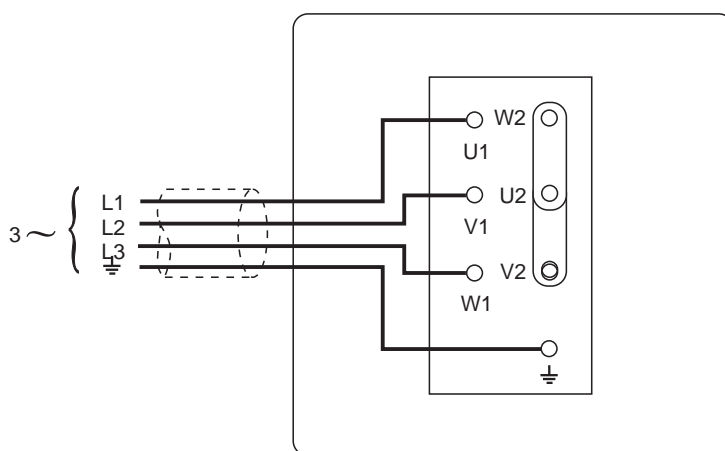

We recommend that you connect the electrical supply to the motor through a starter or circuit breaker which has thermal over-current protection which can be adjusted to suit the full-load current ratings shown in [Table 2](#). The fuse ratings in [Table 2](#) are provided for guidance only. The supplier of your thermal over-current protection device may specify different values to ensure correct operation of the over-current protection device. Ensure that the fuse you use is suitable for the starting currents given in [Table 2](#).

1. Remove the cover from the motor terminal box.
2. Check your electrical supply voltage and frequency. If necessary, configure the motor to operate with your electrical supply (see [Figures 5 and 6](#)).
3. Remove the 20 mm diameter plugs from the cable-entry hole that you will use for the electrical supply cable. Choose the most suitable hole for your application.
4. Fit a suitable cable-gland and nut to the entry hole. After the supply cable is fitted, the cable-gland must be a protective seal to the standard of IP44 in IEC 529 or better.
5. Pass the motor electrical supply cable through the cable-gland.
6. Connect the cables to the terminals as shown in [Figures 5 and 6](#).

3.7.2 Check the direction of rotation

CAUTION

Ensure that the pump-motor rotates in the correct direction. If it does not, the pump and your vacuum system can become pressurised.

1. Watch the motor cooling-fan through the motor fan-cover.
2. Switch-on the electrical supply to the motor for a few seconds and switch off.
3. Check that the motor cooling-fan rotates in the direction shown by the arrow on the motor mounting-plate. If the direction of rotation is incorrect:
 - Isolate the pump from the electrical supply
 - Remove the terminal-box cover and swap wires L1 and L3 (see Figures 5 and 6).
 - Refit the cover to the terminal-box
 - Connect the pump to the electrical supply
 - Check the direction of rotation again.

3.8 Connect the pump inlet to your system

3.8.1 General information

Take note of the following information when you connect the pump to your vacuum system Refer to [Section 7](#) for details of the accessories mentioned below.

- For optimum pumping speeds, ensure that the pipeline connected to the inlet-port is as short as possible and has an internal diameter not less than the inlet-port diameter.
- Support the vacuum pipelines to prevent loading of the coupling-joints.
- If necessary, incorporate flexible bellows in your system pipelines to reduce the transmission of vibration and to prevent loading of coupling-joints. If you use flexible bellows, you must ensure that you use bellows which have a maximum pressure rating which is greater than the highest pressure that can be generated in your system. You must use flexible bellows if your pump is mounted on vibration isolators. We recommend that you use Edwards flexible bellows.
- Use a suitable valve to isolate the pump from your vacuum system if you need to pump condensable vapours or maintain vacuum when the pump is switched off.
- Use a suitable inlet catchpot if you pump condensable vapours or if you use the pump for very dusty applications.
- Ensure that sealing surfaces are clean and scratch-free.

3.8.2 Connect to ISO40 fittings

From the fitting pack, use the two ISO40 Co-seal halves, ISO40/NW40 seal, bolts and washers. Connect to your ISO40 fittings as shown in Figure 7.

3.8.3 Connect to NW40 fittings

From the fitting pack, use the NW40 Co-seal half, ISO40/NW40 seal, the 'C clamp and the bolts and washers. Connect to your NW40 fittings as shown in Figure 8.

Figure 7 - Connect inlet to ISO40 fittings

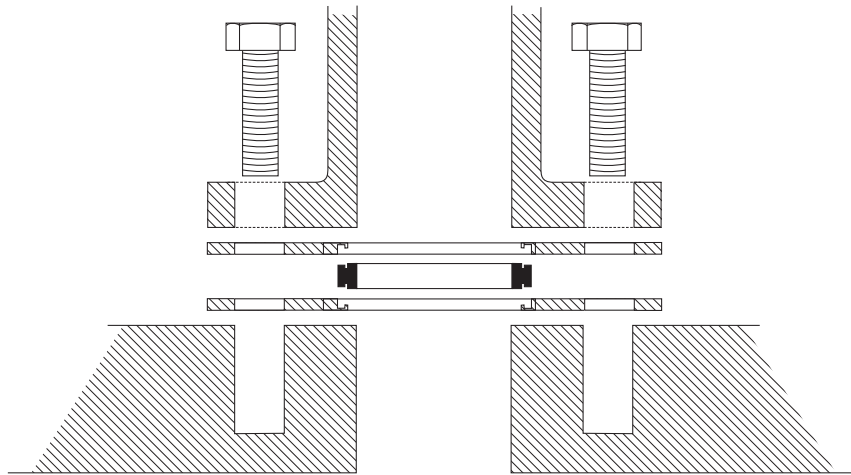
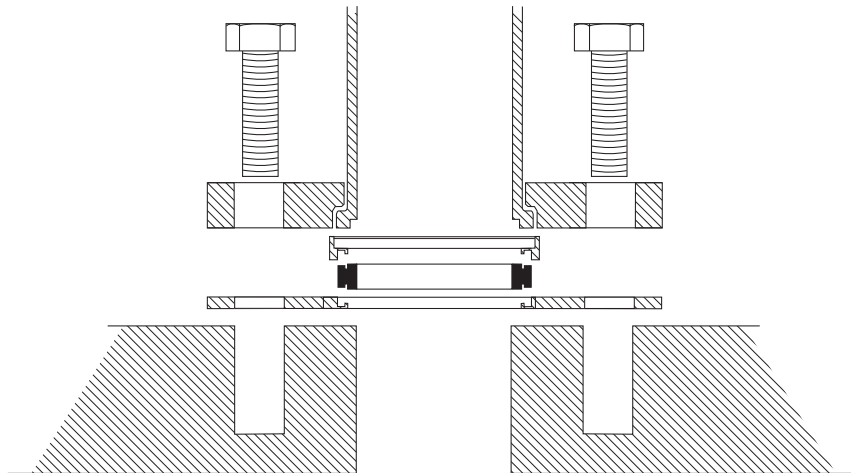

Figure 8 - Connect inlet to NW40 inlet fittings



3.9 Connect the pump outlet to your system



WARNING

Connect the pump outlet to a suitable treatment plant to prevent the discharge of dangerous gases and vapours to the surrounding atmosphere. Use a catchpot to prevent the drainage of contaminated condensate back into the pump.

Connect the pump outlet-port to your outlet accessories or your exhaust treatment plant using the NW25 fittings (supplied).

Take note of the following information before you connect to the pump outlet. Refer to [Section 7](#) for details of the accessories mentioned below.

- The exhaust system must be configured so that the maximum pressure at the pump outlet does not exceed 0.5 bar gauge (1.5 bar absolute, 1.5×10^5 Pa) at full pump throughput.
- In the following circumstances, we recommend that you fit an oil mist filter to the pump outlet:
 - if you use the pump with the gas-ballast control open
 - if you operate the pump with an inlet pressure greater than 10 mbar for extended periods or
 - if you frequently pump down from atmospheric pressure.

The mist filter will trap the oil exhausted from the pump: you can re-use the oil if it is not contaminated.

3.10 Gas-ballast inlet connection

As shown in [Figure 9](#) (item 3), the pump has two gas-ballast inlets. We supply the pump with a blanking plug fitted to one inlet: the other inlet is open. You can use either of the inlets, but you must fit the blanking plug to the inlet you do not use.

You can leave the gas-ballast inlet open to the atmosphere. Alternatively, you can fit a gas-ballast control valve, (available as an accessory, refer to [Section 7](#)), for remote control of the gas-ballast supply. In either case, adjust the gas-ballast control ([Figure 9](#), item 4), to regulate the flow rate of the gas-ballast supply.

For more information about the use of gas-ballast, refer to [Sections 1.3](#) and [4.1](#).

3.11 Leak-test the system

Leak-test the system and seal any leaks found after you have installed the pump, to prevent leakage of substances out of the system and leakage of air into the system.

This page has been intentionally left blank.

4 Operation



WARNING

We do not recommend that you use the E1M40, E2M40, E1M80 and E2M80 pumps to pump hazardous substances.

4.1 Gas-ballast control

Use the gas-ballast control (Figure 1, item 11) to change the amount of air (or inert gas) introduced into the low-vacuum stage of the pump. Use of the gas-ballast will prevent the condensation of vapours in the pump. The condensed vapours would contaminate the oil.

Turn the gas-ballast control fully clockwise:

- to achieve ultimate vacuum
- to pump dry gases.

Turn the gas-ballast control anti-clockwise to open. Use the gas-ballast control fully open:

- to pump high concentrations of condensable vapour
- to decontaminate the oil.

When you operate the pump with the gas-ballast control open, there is an increased rate of oil loss from the pump.

4.2 Start-up procedure



WARNING

Do not block the pump outlet or allow the outlet pressure to rise above 1.5 bar absolute. If you do, the oil box may fracture: this may cause injury to people.

If the oil is contaminated, or if the pump temperature is below 13°C, or if the supply voltage is more than 10% below the lowest voltage specified for the motor, the pump may operate at reduced speed for a few minutes.

1. Switch on the electrical supply to the pump.
2. Check that the oil-level in the sight-glass drops slightly (3 to 5 mm) after start-up. This shows that the pump has primed with oil.
3. If the pump fails to prime, operate the pump with the inlet open to atmosphere for approximately 30 seconds. Then isolate the inlet and check that the oil-level drops 3-5 mm.
4. If you want to achieve ultimate vacuum, to pump condensable vapours or to decontaminate the pump oil, refer to the procedures in Sections 4.3, 4.4 and 4.5 respectively. Otherwise, open the vacuum system isolation-valve.

4.3 To achieve ultimate vacuum

If the pump does not achieve the performance specified in [Section 2](#), make sure that this is not due to your system design before you contact your supplier or Edwards for advice. In particular, the vapour pressure of all materials used in your vacuum system, including pump oil, must be much lower than the specified ultimate vacuum of the pump. Refer to [Section 5.13.2](#) for a list of possible causes for failure to achieve the specified performance. The most common causes are:

- Your pressure measurement technique or gauge head is unsuitable or the gauge head is faulty
- You have used an oil other than the recommended oil, and the vapour pressure of the oil is higher than the specified ultimate vacuum of the pump

Use the following procedure to achieve ultimate vacuum:

1. Isolate the pump from your vacuum system.
2. Turn the gas-ballast control ([Figure 9](#), item 4) fully anti-clockwise (fully open) and operate the pump for at least 1 hour (or overnight) to thoroughly purge the oil of contaminants.
3. Close the gas-ballast control ([Figure 9](#), item 4).
4. Open the vacuum system isolation-valve and pump down to ultimate vacuum.

4.4 To pump condensable vapours

Use gas-ballast when there is a high proportion of condensable vapours in the process gases.

1. Close the vacuum system isolation valve.
2. Turn the gas-ballast control ([Figure 9](#), item 4) anti-clockwise to fully open and operate the pump for 30 minutes to warm the oil. This will help to prevent vapour condensation in the pump.
3. Open the vacuum system isolation-valve and continue to operate the pump with the gas-ballast control open.

After you have pumped condensable vapours, you can (if necessary) decontaminate the oil. Use the procedure in [Section 4.5](#).

4.5 To decontaminate the oil

The oil in the pump should be clear. If the oil is cloudy or discoloured it is contaminated with process vapours.

1. Look at the condition of the oil in the sight-glass ([Figure 1](#), item 7). If the oil is cloudy or discoloured, continue with the procedure at Step 2 below.
2. Close the vacuum system isolation-valve.
3. Turn the gas-ballast control ([Figure 9](#), item 4) fully anti-clockwise.
4. Operate the pump until the oil is clear.

4.6 Unattended operation

The pump is designed for unattended operation under the normal operating conditions specified in [Section 2](#). However, we recommend that you check the pump at a regular interval of not more than 14 days. Check the pump more frequently if you pump high volumes of gas or if you operate the pump with the gas-ballast control ([Figure 9](#), item 4) open.

4.7 Shut-down

Note: *If the gas-ballast control is open and the pump is switched off for any reason, the pump drive shaft may rotate in the reverse direction, causing a system pressure rise. To prevent this, use a gas-ballast control valve (refer to [Section 7.4.10](#)).*

We recommend, as described in the procedure below, that you decontaminate the oil before you shut down the pump. Decontamination of the oil will prevent damage to the pump by the contaminants in the oil.

1. Refer to [Section 4.5](#) and decontaminate the oil, as required.
2. Close the vacuum system isolation-valve (if not already closed).
3. Turn gas-ballast control ([Figure 9](#), item 4) clockwise to close.
4. Switch off the electrical supply to the pump.

This page has been intentionally left blank.

5 Maintenance

5.1 Safety



WARNING

Obey the safety instructions given below and take note of appropriate precautions. If you do not, you can cause injury to people and damage to equipment.

- Ensure that maintenance is done by a suitably trained and supervised technician. Obey your local and national safety requirements
- Ensure that the maintenance technician is familiar with the safety procedures which relate to the pump-oil and the products processed by the pumping system
- Check that all the required parts are available and of the correct type before you start work
- Isolate the pump and other components from the electrical supply so that they cannot be operated accidentally
- Allow the pump to cool to a safe temperature before you start maintenance work
- Do not re-use 'O' rings and seals if they are damaged
- After maintenance is completed, recheck the direction of pump rotation if the electrical supply has been disconnected
- Do not touch or inhale the thermal breakdown products of fluorinated materials which may be present if the pump has been heated to 310° C and above. Fluorinated materials are safe in normal use but can decompose into very dangerous substances (which may include hydrofluoric acid) if they are heated to 310° C and above. The pump may have overheated if it was misused or if it was in a fire. Health and Safety Data sheets for fluorinated materials used in the pump are available on request; contact your supplier or Edwards
- Leak-test the system after maintenance work is complete if you have connected or disconnected any vacuum or exhaust joints; seal any leaks found.
- The pump and the pump-oil will be contaminated with the process chemicals that have been pumped during operation. Ensure that the pump is decontaminated before maintenance and that you take adequate precautions to protect people from the effects of dangerous substances if contamination has occurred.

5.2 Maintenance plan

The plan shown in [Table 4](#) details the routine maintenance operations necessary to maintain your pump in normal use. Instructions for each operation are given in the section shown.

More frequent maintenance may be required if you use your pump with gas-ballast or to pump corrosive or abrasive gases and vapours. If necessary, adjust the maintenance plan according to your experience.

When you maintain the pump, use Edwards spares and maintenance kits; these contain all of the components necessary to complete maintenance operations successfully. The Item Numbers of the spares and kits are given in [Section 7](#).

Examine the condition of any external accessories, filters or traps (if fitted). Refer to the instructions supplied with these accessories for maintenance procedures.

Table 4 - Maintenance plan

Operation	Frequency	Refer to Section
Check the oil-level	Weekly	5.3
Replace the oil	6 months	5.4
Replace the fine oil-filter	Every 3000 hours	5.5
Replace the gas-ballast filter	Every 3000 hours	5.6
Inspect and clean the inlet-filter	Yearly	5.7
Clean the oil-level sight-glass	Yearly	5.8
Clean the motor fan-cover	Yearly	5.9
Clean and overhaul the pump	Yearly	5.10
Test the motor condition	Yearly	5.11
Fit new blades	3 years	5.12

5.3 Check the oil-level

Note: *If required, you can check the oil-level while the pump is operating, however you must switch off the pump and isolate the pump and other components in the pumping system from the electrical supply before you pour oil into the pump*

Refer to [Figure 1](#) for the items in brackets.

1. Check that the oil-level in the sight-glass (7) is between the MAX and MIN level marks on the bezel of the sight-glass.
2. If the oil-level is near to or below the MIN level mark, remove the oil filler-plug (6) and pour more oil into the reservoir until the oil reaches the MAX level mark. If the oil-level goes above the MAX mark, open the oil drain-tap (8) and drain the excess oil from the pump. When the oil level falls to the MAX mark, close the oil drain-tap (8). Refit the oil filler-plug.
3. Refit the oil filler-plug (6), tighten the plug firmly by hand. Do not over-tighten.
4. If the oil is contaminated, drain and refill the pump with clean oil as described in [Section 5.4](#).

5.4 Replace the oil

Refer to [Figure 1](#) for the items in brackets.

1. Operate the pump for approximately ten minutes to warm the oil, then switch off the pump (this lowers the viscosity of the oil and enables it to be drained from the pump more easily)
2. Isolate the pump from your electrical supply and disconnect it from your vacuum system.
3. Remove the oil filler-plug (6).
4. Place a suitable container under the drain-tap (8). Open the drain-tap and allow the oil to drain into the container.
5. If the oil drained from the pump is contaminated, pour clean oil into the filler-hole and allow it to drain out of the pump. Repeat this step until the oil reservoir in the pump has been thoroughly cleaned.
6. Close the drain-tap (8).
7. Fill a suitable container with clean oil and pour the oil into the filler hole until the oil-level reaches the MAX level mark on the bezel of the sight-glass (7).
8. Allow a few minutes for the oil to drain into the pump. If necessary, add more oil. Refit the filler-plug.
9. Replace the fine oil-filter (see [Section 5.5](#)).
10. Replace the gas-ballast filter (see [Section 5.6](#)).
11. Reconnect the pump to your vacuum system.
12. Reconnect the electrical supply to your pump.

5.5 Replace the fine oil-filter

Figure 9 - Fine oil-filter and gas-ballast bearing-plate locations

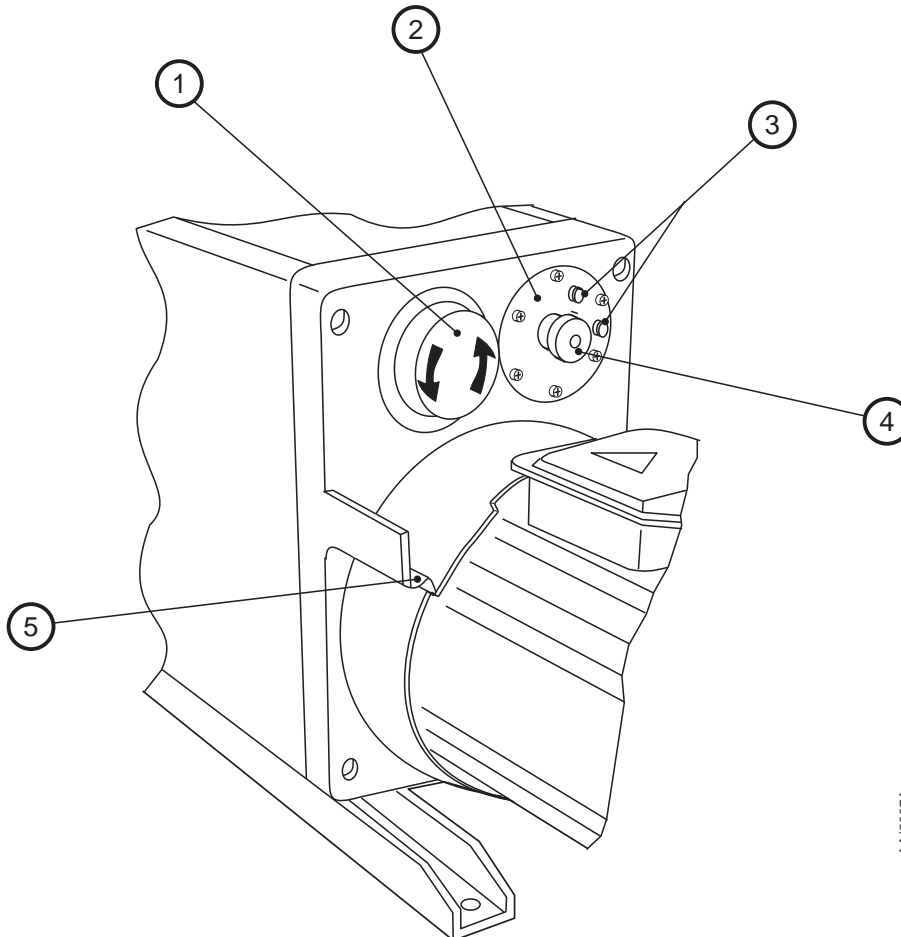

AA/5007A

1. Fine oil-filter
2. Gas-ballast bearing-plate assembly
3. Gas-ballast inlets
4. Gas-ballast control
5. Oil drain-scoop

You must replace the fine oil-filter every time you change the oil in the pump. See [Figure 9](#).

1. Isolate the pump from your electrical supply.
2. Place a suitable container underneath the oil drain scoop (5) below and to the left of the fine oil-filter (1). This will contain any oil spill from the filter when it is unscrewed. The filter capacity is about 400 ml.
3. Unscrew the filter (direction arrows shown in [Figure 9](#)) using a suitable strap-wrench. Clean off any oil-spillage on pump and filter housing surfaces. Dispose of the filter and any oil-spillage according to local environment regulations covering industrial waste.
4. Make sure that the filter sealing ring (supplied with the new filter) is seated correctly on the new filter. Screw in the new filter and tighten $\frac{1}{4}$ turn using the strap-wrench.

5.6 Replace the gas-ballast filter

You must replace the gas-ballast filter elements every time you change the oil in the pump (see [Figure 9](#)).

1. Isolate the pump from your electrical supply.
2. Unscrew and remove the M6 x 16 mm long socket-head screws securing the gas-ballast bearing-plate (2).
3. Note the orientation of the bearing-plate before removing it so that you can replace it correctly later.
4. Remove the bearing-plate containing the two filter elements from the valve body.
5. Slide the two filter elements off the bearing-plate and discard them.
6. Clean the bearing-plate assembly before fitting new filter elements by washing it in a suitable cleansing solution. Allow the assembly to dry.
7. Fit two new filter elements to the bearing-plate.
8. Replace the assembly into the valve body in the correct orientation and secure with the two screws removed earlier.
9. Reconnect the electrical supply to your pump.

5.7 Inspect and clean the inlet-filter

You must remove and clean the inlet-filter (positioned in the inlet-port) every time you change the oil in the pump (see Figure 10).

Figure 10 - Remove and replace inlet-filter

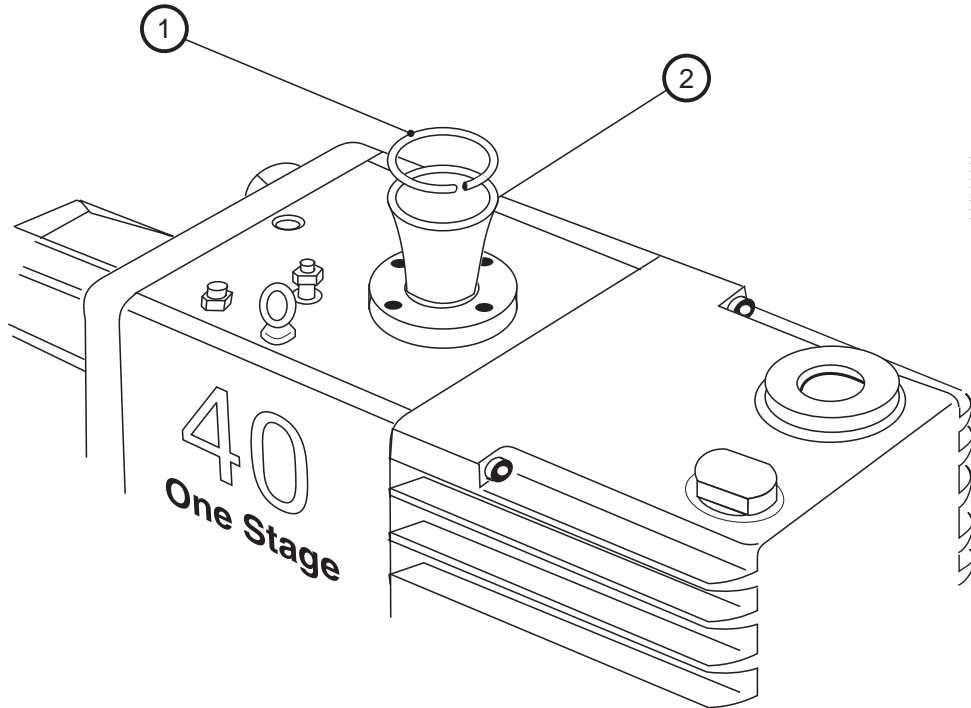

1. Filter retainer-circlip
2. Inlet-filter

1. Isolate the pump from your electrical supply.
2. Disconnect the pump from your vacuum system.
3. Remove the filter retainer-circlip (1) and withdraw the inlet-filter (2).
4. Clean the inlet-filter by washing it in a suitable cleaning solution. Allow the filter to dry.
5. Refit the inlet-filter (2) and the filter retainer-circlip (1).
6. Reconnect the pump to your vacuum system.
7. Reconnect the electrical supply to your pump.

5.8 Clean the oil-level sight-glass

Figure 11 - Oil-level sight-glass assembly

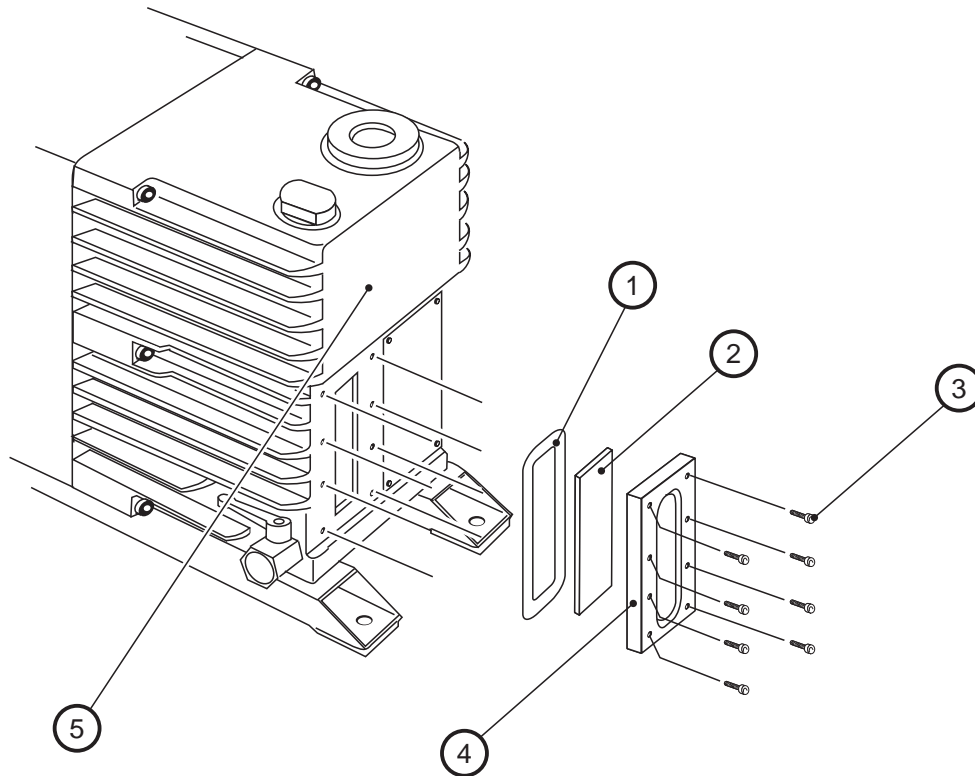

- 1. Sight-glass seal
- 2. Sight-glass
- 3. Screws (8 off M6 x20)
- 4. Bezel
- 5. Oil-box

Refer to [Figure 11](#) for the item numbers in brackets.

1. Drain the oil as described in [Section 5.4](#).
2. Undo the eight screws (3) and remove the bezel (4), the sight-glass (2) and the sight-glass seal (1) from the oil-box (5).
3. Clean the screws, bezel and sight-glass with a suitable cleaning solution.
4. Wipe the sight-glass seal with a clean, dry, lint-free cloth.
5. Wipe the sight-glass recess in the oil-box with the cloth.
6. Refit the sight-glass seal, sight-glass and bezel and secure with the eight screws.
7. Refill the pump with oil as described in [Section 5.4](#).
8. Check that the sight-glass does not leak.

5.9 Clean the motor fan-cover

You must keep the motor fan-cover clean. Your pump may overheat if the air-flow over the motor is restricted.

1. Isolate the pump from your electrical supply.
2. Use a dry cloth and a brush to remove dirt and deposits from the fan-cover.
3. Reconnect the electrical supply to your pump.

5.10 Clean and overhaul the pump

Clean and overhaul the pump as described in the instructions supplied with the clean and overhaul kit (see [Section 7](#)).

5.11 Test the motor condition

Test the earth continuity and the insulation resistance of the pump-motor, in accordance with local regulations for periodic testing of electrical equipment. We recommend that the earth continuity is less than 0.1Ω and the insulation resistance is greater than $10 M\Omega$. If the motor fails these tests, you must replace the motor.

5.12 Fit new blades

Fit new blades to the pump as described in the instructions supplied with the blade kit (see [Section 7](#)).

5.13 Basic fault-finding

A list of fault conditions and their possible causes is provided here to assist you in fault-finding. If you are unable to rectify a fault when you use this guide, call your nearest Edwards Service Centre for help.

5.13.1 The pump has failed to start

- The electrical supply fuse is blown
- The electrical supply voltage does not match the motor
- The outlet pipeline or the outlet-filter (if fitted) is blocked
- The oil temperature is below 12 °C
- The oil is too viscous
- The oil is contaminated
- The pump has seized after long storage
- The pump has been left to stand after contaminants have been pumped and has seized
- The motor is faulty.

5.13.2 The pump fails to achieve its specified performance

(Failure to reach ultimate vacuum).

- The measuring technique or gauge is unsuitable
- You have filled the pump with the wrong type of oil
- There is a leak in your vacuum system
- The gas-ballast control is set incorrectly
- The oil-level is low
- The oil is contaminated
- Your vacuum fittings are dirty or damaged
- The inlet-filter is blocked
- The pump has not warmed up
- The pump has failed to prime
- Motor is rotating in the wrong direction.

5.13.3 The pump is noisy

- The motor fan-cover is damaged
- The motor bearings are worn
- The oil is contaminated with solid particles
- The motor coupling is loose
- A blade is sticking.

5.13.4 The pump is too hot

- The ambient temperature is too high
- The cooling-air supply is insufficient or is too hot
- The electrical supply voltage is too high
- The outlet-filter or the outlet pipeline is blocked
- The oil-level is too low
- You have filled the pump with the wrong type of oil
- The oil is contaminated
- The process gas is too hot or the throughput is too high.

5.13.5 The vacuum is not fully maintained after the pump is switched off

- The gas-ballast control is open
- Damaged or missing 'O' ring
- Anti-suckback valve faulty
- Shaft seals damaged
- Exhaust valve damaged

5.13.6 The pumping speed is poor

- The connecting pipelines are too small in diameter
- The connecting pipelines are too long
- The inlet-filter is blocked

5.13.7 There is an external oil leak

- The oil-pump shaft-seal is worn or damaged
- The oil-box gaskets have deteriorated
- There is an oil leak from the gas-ballast control
- There is an oil leak from the drain-tap
- There is an oil leak from the sight-glass
- There is an oil-leak from the fine oil-filter element-seal.

This page has been intentionally left blank.

6 Storage and disposal

6.1 Storage

CAUTION

Observe the storage temperature limits stated in [Section 2](#). Storage below -30°C will permanently damage the pump seals.

Note: *If you will store a new pump in conditions of high humidity, remove the pump from its cardboard packaging box; dispose of the box (refer to [Section 6.2](#)).*

Use the following procedure to store the pump:

1. Ensure that the pump has been shut-down as described in [Section 4](#).
2. Isolate the pump from the electrical supply.
3. Purge your vacuum system and the pump with dry nitrogen and disconnect the pump from your vacuum system.
4. Replace the oil as described in [Section 5.4](#), paragraphs 3 to 8.
5. Place and secure protective covers over the inlet and outlet-ports.
6. Store the pump in cool, dry conditions until required for use.
7. When required, prepare and install the pump as described in [Section 3](#). If the pump has been stored for more than a year, before you install the pump you must clean and overhaul it as described in the instruction supplied with the clean and overhaul kit.

6.2 Disposal

Dispose of the pump, cleaning solutions, deposits removed from the pump, used pump oil, coolant, grease and any components safely in accordance with all local and national safety and environmental requirements.

Particular care must be taken with the following:

- Fluoroelastomers which may have decomposed as a result of being subject to high temperatures.
- Components and oil which have been contaminated with dangerous process substances.

This page has been intentionally left blank.

7 Spares and accessories

7.1 Introduction

Edwards products, spares and accessories are available from Edwards companies in Belgium, Brazil, Canada, France, Germany, Hong Kong, Italy, Japan, Korea, Singapore, Switzerland, United Kingdom, U.S.A, and a world-wide network of distributors. The majority of these centres employ Service Engineers who have undergone comprehensive Edwards training courses.

Order spare parts and accessories from your nearest Edwards company or distributor. When ordering, please state for each part required:

- Model and Item Number of your equipment
- Serial number (if any)
- Item Number and description of part.

7.2 Service

Edwards products are supported by a worldwide network of Edwards Service Centres. Each Service Centre offers a wide range of options including: equipment decontamination; service exchange; repair; rebuild and testing to factory specifications. Equipment which has been serviced, repaired or rebuilt is returned with a full warranty.

Your local Service Centre can also provide Edwards engineers to support on-site maintenance, service or repair of your equipment.

For more information about service options, contact your nearest Centre or other Edwards company.

7.3 Spares

The following maintenance kits contain all of the parts you will need to maintain your pump. The maintenance kits also include instructions for the use of the kits. Use the Clean and Overhaul Kit for routine maintenance operations. Use the Blade Kit together with the Clean and Overhaul Kit when you must renew the blade assembly in the rotary pump.

Pump	Kit Description	Item Number
E1M40 and E2M40	Clean and Overhaul Kit	A344-01-131
E1M40	Blade Kit	A344-01-050
E2M40	Blade Kit	A364-01-050
E1M40	Major Service Kit	A344-01-814
E2M40	Major Service Kit	A364-01-814
E1M40	Interior Assembly	A344-01-100
E2M40	Interior Assembly	A364-01-100
E1M80	Interior Assembly	A345-01-100
E2M80	Interior Assembly	A365-01-100
E1M80 and E2M80	Clean and Overhaul Kit	A345-01-131
E1M80	Blade Kit	A345-01-050
E2M80	Blade Kit	A365-01-050
E1M80	Major Service Kit	A345-01-814
E2M80	Major Service Kit	A365-01-814
All models	Fine oil-filter	A223-04-041
All models	Common Seals Kit	A344-01-820

7.4 Accessories

A range of accessories is available for the E1M40, E2M40, E1M80 and E2M80 pumps.

7.4.1 Inlet dust-filter

The inlet dust-filter is a nylon-fibre filter-element which protects your pump against abrasive dust (see [Figure 12](#), item 1). You can check the filter element by looking through a glass cover at the top of the filter. The filter is supplied with bolts, washers, 40 mm 'O' ring and centring ring.

Product	Item Number
ITF100 Inlet Dust Filter	A442-02-000

7.4.2 Inlet catchpot

The inlet catchpot traps liquid droplets and prevents their entry into the pump (see [Figure 12](#), item 1). You can check the liquid level in the catchpot by looking through a glass cover at the top of the catchpot. The catchpot is supplied with bolts, washers, 40 mm 'O' ring and centring ring.

Product	Item Number
ITO100 Inlet Catchpot	A441-02-000

7.4.3 High-capacity inlet dust-filter

The high-capacity inlet dust-filter (see [Figure 12](#), item 1) is a wire mesh filter. You use this filter where you have fast pump down times and where high levels of dust and grit are involved. You can check the filter element by looking through a glass cover at the top of the filter. The filter is supplied with bolts, washers, 40 mm 'O' ring and centring ring.

Product	Item Number
ITM100 High Capacity Dust Filter	A443-02-000

7.4.4 Inlet chemical-trap

The inlet chemical-trap (see [Figure 12](#), item 1) protects your pump against chemically active gases which may attack your pump or pump oil. You must provide the trapping material suitable for your application. The trapping material is contained in a removable fine mesh container supplied with the inlet chemical-trap. You can check the chemical-trap by looking through a glass cover at the top of the chemical trap. The chemical trap is supplied with bolts, washers, 40 mm 'O' ring and centring ring

Product	Item Number
ITC100 Inlet Chemical Trap	A444-02-000

7.4.5 Outlet catchpot

If your pump outlet is piped for remote discharge, condensed pipeline vapour could drain back to your pump. The outlet catchpot (see [Figure 12](#), item 5) collects the liquid. You can see from a sight-glass indication when you need to drain the catchpot. The catchpot is supplied with two NW25 'C clamps, NW25 elbow, two NW25 centring rings and 'O' rings, bolts, washers, mounting bracket and studs.

Product	Item Number
CP100 Outlet Catchpot	A461-03-000

7.4.6 Outlet mist-filter (clean applications)

The outlet mist-filter (see [Figure 12](#), item 5) collects the oil contained in the oil-mist forming part of the discharge gases. You can monitor the level of oil trapped in the filter, through a sight-glass. This mist-filter must only be used for clean applications, for other applications see [Section 7.4.7](#). You can return the trapped oil to your pump using the oil return kit. The mist-filter is supplied with two N W25 'C clamps, NW25 elbow, two N W25 centring rings and 'O' rings, bolts, washers, mounting bracket and studs.

Product	Item Number
MF100 Mist Filter	A462-03-000
Clean Application Oil Return Kit	A500-04-000

7.4.7 Outlet mist-filter (toxic applications)

The outlet mist-filter (see [Figure 12](#), item 5) collects the oil contained in the discharge gases. You can monitor the level of contaminants through a sight-glass. You must check that the specification of the mist-filter you choose is suitable for your application. The mist filter is supplied with two NW25 'C clamps, NW25 elbow, two NW25 centring rings and 'O' rings, bolts, washers, mounting bracket and studs.

Product	Item Number
MF100AE Mist Filter	A462-11-000

7.4.8 External oil filter

The external oil filter (see [Figure 12](#), item 3 or 4) is a free-standing filter. You can choose between two types of oil-filter. The 'A' series uses an activated earth cartridge which provides chemical cleaning of the oil by removing acidic and other aggressive contaminants. The 'M' series uses a pleated paper cartridge which does not provide chemical filtering but removes abrasive particles down to 0.5 microns. The series 'A' and series 'M' oil-filters are available in two sizes; the EOF100 has a 6-litre capacity, the EOF300 has a 15-litre capacity. You must check that the external oil filter you choose is suitable for your application.

Product	Item Number
EOF100A External Oil Filter	A500-24-000
Activated Earth Element for EOF100A	A223-04-043
EOF300A External Oil Filter	A500-03-000
Activated Earth Element for EOF300A	A223-04-033
EOF100M External Oil Filter	A500-25-000
Mechanical Filter Element for EOF100M	A223-04-044
EOF300M External Oil Filter	A500-23-000
Mechanical Filter Element for EOF300M	A223-04-042
EOF100A and M Connection Kit	A500-39-000
EOF300A and M Connection Kit	A364-01-020

7.4.9 Oil-level monitor

The oil-level monitor (see [Figure 12](#), item 7) fits in place of the existing oil-level sight-glass and bezel. The monitor provides a switching facility which you can use to activate an alarm or other device. You still have the normal visual indication of the oil-level.

Product	Item Number
OLM100 Oil Level Monitor	A504-33-000

7.4.10 Solenoid-operated gas-ballast control valve

The solenoid-operated gas-ballast control valve (see [Figure 12](#), item 2) gives you automatic or remote control of gas-ballast. You can connect the valve to shut off gas-ballast when the pump is switched off and so prevent air from returning to the system.

Product	Item Number
EBV100S Solenoid-Operated Gas-Ballast Control Valve for E1M40 and E1M80	A500-18-930
EBV300D Solenoid-Operated Gas-Ballast Control Valve for E2M40 and E2M80	A500-17-930

7.4.11 Vibration isolators

Use vibration isolators (see Figure 12, item 6) to reduce vibration and noise when the pump is floor or frame-mounted. You must use flexible bellows or other flexible piping between inlet and outlet connections when you fit vibration isolators.

Product	Item Number
Vibration Isolators (set of 4)	A248-01-405

Figure 12 - Accessories

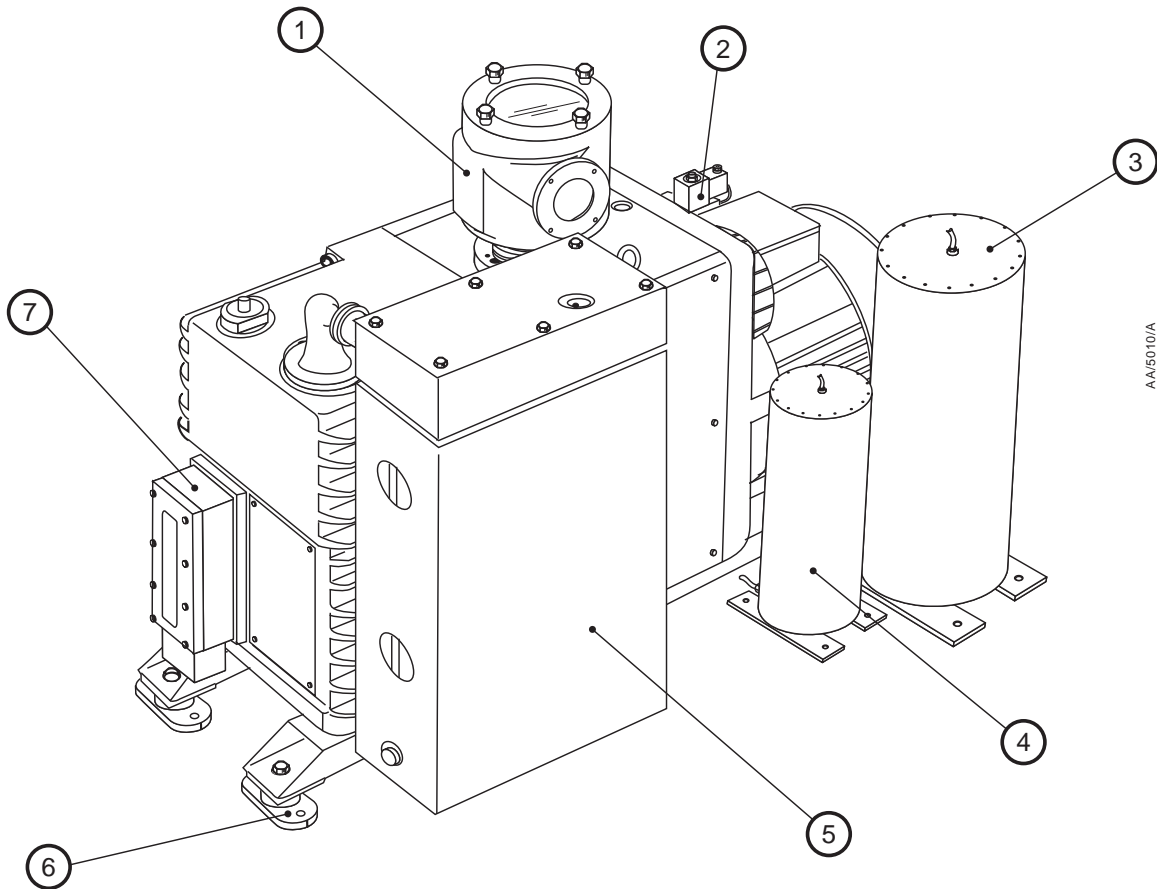

AAJ5010/A

1. Inlet dust-filter or inlet catchpot or inlet chemical trap or high capacity inlet dust-filter
2. Solenoid-operated gas-ballast valve
3. External oil-filter (15-litre capacity)
4. External oil-filter (6-litre capacity)
5. Outlet catchpot or outlet mist-filter
6. Vibration isolator
7. Oil level monitor

Appendix A E2M40S and E2M80S (Superpumps)

A1 Introduction

A1.1 Scope of this appendix

This appendix provides additional information about the E2M40S and E2M80S. Read this appendix in conjunction with the instructions in the main sections in this manual.

A1.2 Description

A1.2.1 Construction

The Superpump pumps differ from the standard pump models as follows:

- Internal parts have been designed to ensure reduced maintenance time and an increase in the pump running efficiency
- There is no fine oil-filter element
- The oil filler cap is replaced by a non-return valve and inlet union for use with dry nitrogen oil-box purge
- The gas-ballast adjustor knob is replaced by a dry nitrogen inlet pipe union and solenoid valve assembly; see [Figure A2](#).

A1.2.2 Purpose of dry nitrogen gas-ballast

Dry nitrogen is injected into the pump stator through the gas-ballast solenoid valve to prevent the majority of any corrosive gases condensing during the compression cycle of the pump. This form of gas-ballast is also used to lightly pressurise the void between the rotor and shaft seals and assists in preventing any leakage of pump oil. You can check the condition of the shaft seals by reducing the dry nitrogen gas pressure to zero (at the gas-ballast flow regulator) while the pump is operating. Any shaft seal oil leakage is indicated by the presence of oil in a clear section of the gas-ballast external return pipe; see [Section A2](#).

Dry nitrogen is also introduced through a pipe union and non-return valve into the oil-box. This oil-box purge is used when pumping flammable or toxic gases, where large scale dilution in the oil-box is necessary for safety reasons.

This page has been intentionally left blank.

A2 Technical data

A2.1 Performance

		E2M40S	E2M80S
Ultimate vacuum (with pfpe partial pressure) without gas-ballast	mbar	2×10^{-3}	2×10^{-3}
	(Pa)	(2×10^{-1})	(2×10^{-1})
with gas-ballast	mbar	5×10^{-3}	5×10^{-3}
	(Pa)	(5×10^{-1})	(5×10^{-1})
Maximum gas-ballast flow	lmin ⁻¹	5 to 7	5 to 7
Minimum dry nitrogen flow	lh ⁻¹	500	500

A2.2 Lubrication data

Note: An Edwards Health and Safety Data Sheet for the following oil is available on request. See Associated publications on contents [page iv](#).

Recommended oil grade	Edwards Fomblin pfpe Y/LVAC 06/6 or Krytox pfpe 1506	
	E2M40S	E2M80S
Oil capacity, pump only (litres)		
Maximum	3.0	4.0
Minimum	1.3	2.0

A2.3 Electrical data: three-phase motors

The pumps are available with the three-phase motor specified in [Table A1](#). The dual voltage motors can be manually set-up to work with the nominal supplies of 220-240 V, 380-415 V, or 208-230 V (Refer to [Section 3.7](#)). Dual voltage motors are supplied preset to the highest of the selectable voltages.

Table A1 - Electrical data (three-phase motors)

Pump	Nominal supply (V)	Frequency (Hz)	Power (kW)	Full load current (A)	Start-up current (A)	Recommended fuse rating (A)*	Electrical connection Figure
E2M40S	208	50	1.5	6.8	41	25	5
	208-230	60	1.5	6.5	39	25	5
	460	60	1.5	3.1	18.6	15	6
E2M80S	208	50	3	12.4	71	40	5
	208-230	60	3	11.8	71	40	5
	460	60	3	5.6	34	20	6

* You may need to use a different fuse rating. Use the information supplied with your circuit breaker or starter to select the correct fuse rating.

A3 Installation

A3.1 Pump external fittings, connections and controls

You should familiarise yourself with the external fitting points, connections and controls on the pump. See Figures A1 and A2.

Figure A1 - External oil-filtration unit tapping points

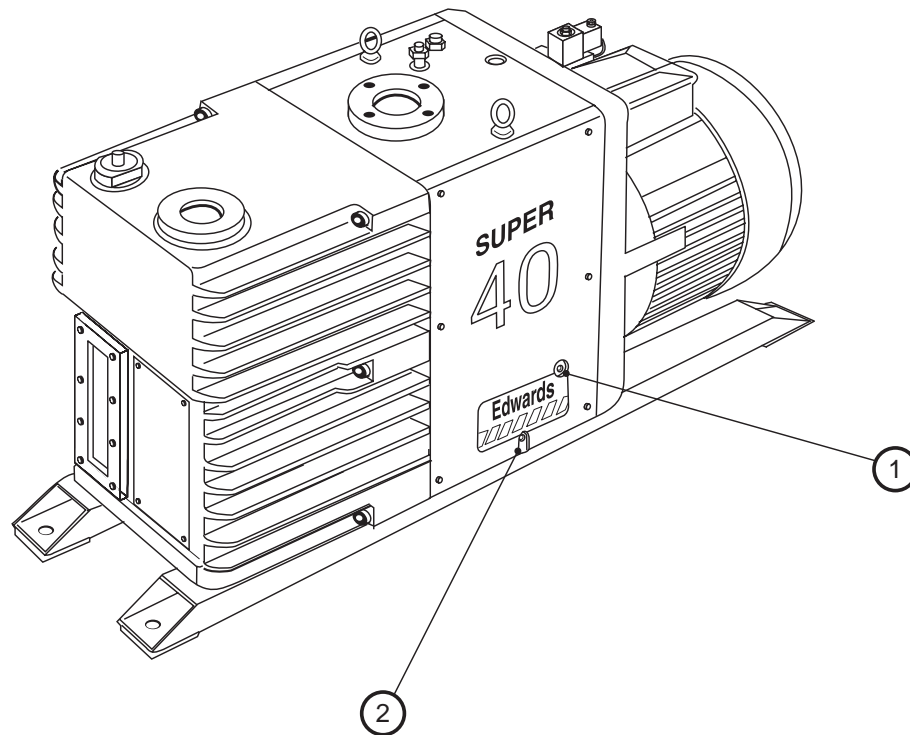

AA/5011/A

1. External oil-filtration pipe outlet-connection
2. External oil-filtration pipe inlet-connection

Figure A2 - External fittings, connections and controls

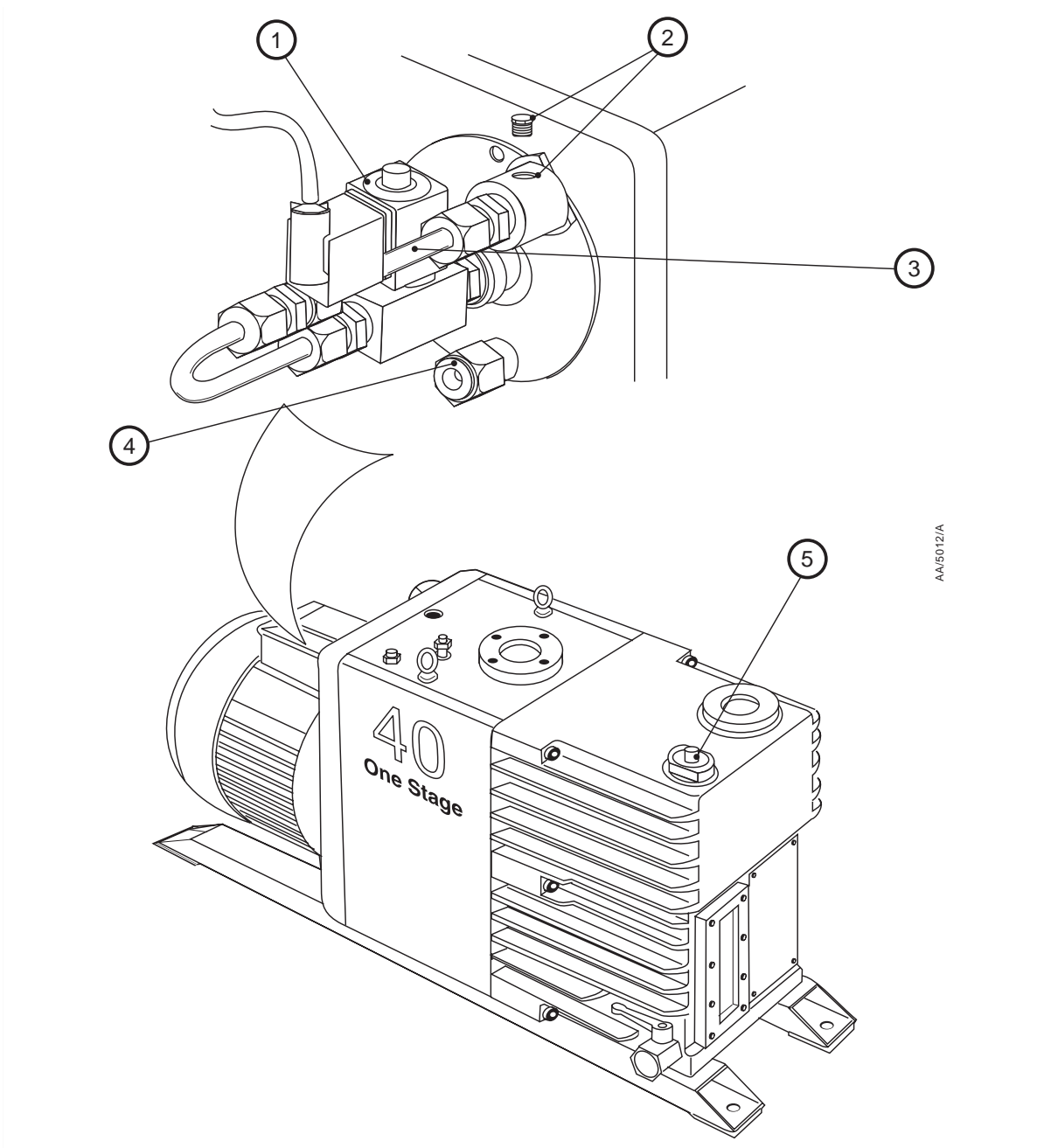

AA/5012/A

- 1. Gas-ballast solenoid-valve
- 2. Shaft-seal pressure monitoring-point
- 3. Shaft-seal leakage viewing-tube
- 4. Inlet-union for dry nitrogen gas-ballast to shaft-seals
- 5. Inlet-union and non-return valve for dry nitrogen oil-box purge

A3.2 Fill the pump with oil



WARNING

Prevent direct skin contact with the oils and greases in this pump. Use suitable protective clothing. These oils can cause inflammation of the skin after prolonged contact.

Fill the pump with oil as described below. Refer to [Figure A2](#) for the item numbers in brackets.

1. Unscrew and move aside the pipe on the dry nitrogen non-return valve (5) on top of the oil-box. Remove the non-return valve.
2. Pour oil into the pump until the oil-level just reaches the MAX mark on the bezel at the top of the sight-glass. If the oil-level goes above the MAX mark, open the oil drain tap and drain the excess oil from the pump. You will need additional oil if an external oil nitration unit is fitted. Refer to the instructions supplied with your filter; see Associated publications on contents [page iv](#) of this manual.
3. After a few minutes, recheck the oil-level. If the oil-level is now below the MAX mark, pour more oil into the pump.
4. Screw the non-return valve (5) back into the oil-box and tighten down firmly; re-connect the pipe.

This page has been intentionally left blank.

A4 Operation

The pumps are designed for continuous operation.

CAUTION

If the pump is stopped for any reason; the dry nitrogen supply to the regulators must be switched off. This eliminates the need to reset the regulators and also prevents possible oil pump priming problems on re-start when the system is under vacuum.

Note: Refer to *Figure A3*. If you wish to continue to purge the oil-box after the pump has stopped you need only switch off the supply to the gas-ballast by closing the flow regulator (5) to the gas-ballast.

A4.1 Start-up

Refer to Figure A3. Before you start the pump, check the following additional points:

- Check the pressure regulator for the dry nitrogen supply to the gas-ballast solenoid and shaft-seals is set to 4 psi.
- Check the pressure regulator for the dry nitrogen supply to the oil-box is set to 7 psi.

Figure A3 - Typical dry nitrogen gas circuit

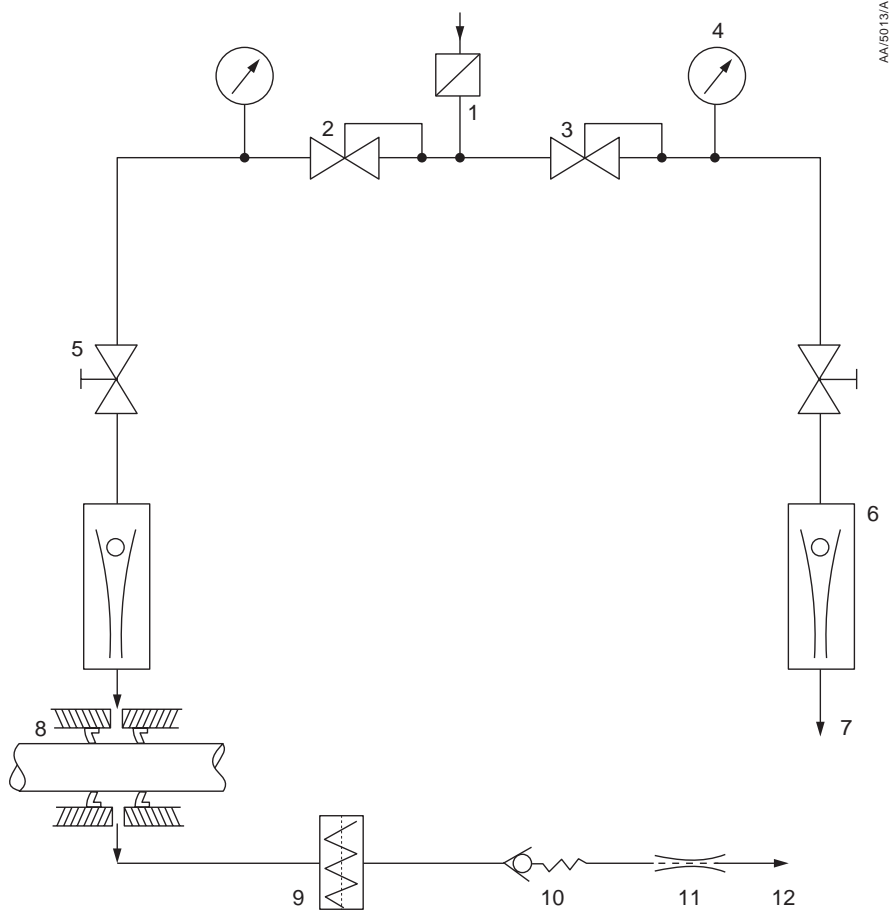

AA/6013/A

- | | |
|---|------------------------------------|
| 1. Filtered dry nitrogen supply (~50 psi) | 7. Dry nitrogen gas to oil-box |
| 2. Pressure regulator (set 4 psi) | 8. Main shaft-seals |
| 3. Pressure regulator (set 7 psi) | 9. Solenoid valve |
| 4. Pressure gauge (0-30 psi) | 10. Non-return valve |
| 5. Flow regulator valve | 11. Fixed restrictor |
| 6. Flow meter | 12. Dry nitrogen gas-ballast input |

A4.2 Shut-down

1. Close off the dry nitrogen supply to the regulators.
2. Close the gas-ballast solenoid-valve to maintain the system vacuum when the pump is shut down.
3. Switch off the electrical supply to the pump.

This page has been intentionally left blank.

A5 Spares

The following maintenance kits are available for your pump. The maintenance kits also include instructions for the use of the kits.

Pump	Kit Description	Item Number
E2M40S	Spares kit	A364-13-801
E2M80S	Spares kit	A365-13-801

This page has been intentionally left blank.