

WELCH-ILMVAC

OWNER'S MANUAL FOR WOB•L® PISTON VACUUM PUMP MODELS:

2561B-50 2563B-24
2561C-50 2563C-24
2561C-56 2563C-25



Warning
Not recommended for pumping acid, base or organic vapors or gases.



Warning
Be sure to properly identify intake and discharge before using pump.
See section 2.5

For outside of U.S. and Canada, contact your local
Gardner Denver sales office.

Welch-Ilmvac
5621 W. Howard Street
Niles, IL 60714
Phone: (847) 676-8800 (Technical Support)
Fax: (847) 677-8606
E-Mail: gdwelchvacuum@gardnerdenver.com
Web-Page: www.welchvacuum.com

for more info [CLICK HERE](#)
Ideal
vacuum products
www.idealvac.com

Part No. 642826
Printed in USA

INSTRUCTION
WARNING AND CAUTION
PLEASE READ BEFORE OPERATION

While reading your manual, please pay close attention to areas labeled:
WARNING AND CAUTION.

The description of each is found below.

WARNING

Warnings are given where failure to observe instruction could result in injury or death to people.

CAUTION

Cautions are found where failure to observe the instruction could result in damage to the equipment, associated equipment and process.

These units conform to the SI International system of units of measurement.

The following symbols (with recommendation of IEC1010) of warning will be found on the pump.



Caution - Refer to accompanying documents



Caution - Risk of electrical shock



Caution - Hot surface

WARNING

Motor includes a self resetting thermal cutout and the pump could restart without actuation under fault condition.

TABLE OF CONTENTS

Section 01 - Safety Information

- 1.10 Warning to prevent injury
- 1.20 Warning to reduce risk of electrical shock
- 1.30 Warning to reduce risk of electrocution
- 1.40 Warning to reduce risk of explosion or fire

Section 02 - Installation

- 2.10 Introduction
- 2.20 Unpacking
- 2.30 Pump mounting
- 2.40 Pump location / Environmental conditions
- 2.50 Intake and discharge provisions
- 2.60 Electrical power
- 2.70 Vacuum connections
- 2.80 Vacuum and gauges
- 2.90 Traps

Section 03 - Operation

- 3.10 Starting procedures
- 3.20 Leak detection
- 3.30 Pressure range
- 3.40 Shutdown procedures

Section 04 - Maintenance

- 4.10 General Maintenance

Section 05 - Troubleshooting

- 5.10 Vacuum problems
- 5.20 Troubleshooting table

Section 06 - Specifications

- 6.10 Specification chart
- 6.20 Pumping speed curve

Section 07 - Warranty

Section 08 - Exploded views and parts list

- 8.10 Dimensional Drawing
- 8.20 Exploded view and parts list

Section 1: SAFETY INFORMATION

- 1.10 WARNING: TO PREVENT INJURY...
- 1.11 Never operate this product if it has a damaged cord or plug. If it is not working properly, has been dropped, damaged or has fallen into water, please return the product to a Welch service center for examination and repair.
- 1.12 Keep the cord away from heated surfaces. All electrical products generate heat. To avoid serious burns never touch unit during or immediately after operation.
- 1.13 Never block any air openings or place it on a soft surface where the openings may be blocked. The air openings are for ventilation of the motor inside the housing. Keep all air openings free of lint, dirt and other foreign objects.
- 1.14 Never drop or insert fingers or any other object into any openings.
- 1.15 Do not operate this product where oxygen is being administered.
- 1.16 This pump is thermally protected and can automatically restart when the protector resets. Always disconnect power source before servicing.
- 1.17 Wear safety glasses and goggles when operating this product. Never point any air nozzle or air sprayer toward another person or any part of the body.
- 1.18 Use only in well ventilated areas. The motor on all pumps are totally enclosed fan cooled
- 1.19 Do not use any tools or attachments without first determining maximum air pressure for that tool or attachment. Be sure to properly identify intake and discharge before using pump. See Section 2.50

- 1.20 WARNING: TO REDUCE RISK OF ELECTRICAL SHOCK...
- 1.21 Do not disassemble. Disassembly or attempted repairs if accomplished incorrectly can create electrical shock hazard. Refer servicing to qualified service agencies only.
- 1.22 Unit is supplied with a three pronged plug. Be sure to connect pump to a properly grounded outlet only.

- 1.30 WARNING: TO REDUCE RISK OF ELECTROCUTION...
- 1.31 Do not use this product in or near area where it can fall or be pulled into water or other liquids.
- 1.32 Do not reach for this product if it has fallen into liquid.
- 1.33 Never operate this product outdoors in the rain or in a wet area.

- 1.40 WARNING: TO REDUCE RISK OF EXPLOSION OR FIRE...
- 1.41 Do not use this pump in or near explosive atmospheres or where aerosol (spray) products are being used.
- 1.42 Do not pump anything other than atmospheric air.
- 1.43 Do not pump combustible liquids or vapors with this product or use in or near an area where flammable or explosive liquids or vapors may exist.
- 1.44 Do not use this product near flames.



WARNING

Failure to observe the above safety precautions could result in severe bodily injury, including death in extreme cases.

Section 2: INSTALLATION

2.10 INTRODUCTION

2.11 This manual has been compiled not only for the care and maintenance of the Welch Dry Vacuum Pump now in your possession, but as a helpful reference and guide to prevent many problems which occur if used improperly

2.20 UNPACKING

2.21 Carefully remove the Vacuum Pump from the shipping case and unfasten and remove the wooden skid. Preserve all paperwork for future reference. If damage has occurred from shipment, a claim must be filed with the carrier immediately; preserve the shipping carton for inspection by the carrier. If you are required to communicate with your dealer or Welch Vacuum Technology, be sure to include your order numbers for quick identification. Do not return the pump to the factory without first calling for a return goods number.

2.30 PUMP MOUNTING

2.31 Rubber feet are attached to the pump. Rubber feet are excellent for applications involving a semi-flexible surface such as a bench top; they help to isolate noise and eliminate creeping. All Vacuum Pumps should be mounted on a horizontal plane.

2.40 PUMP LOCATION / ENVIRONMENTAL CONDITIONS

2.41 Pump Location:

The Vacuum Pump should be located preferably in a clean, dry, and well ventilated area. Please be sure not to block the ventilation holes located on the motor housing. The pump should be placed where the surrounding temperature remains between 10°C and 40°C (50°F and 104°F). Always check to insure the location chosen is protected from direct or indirect moisture contact. Welch recommends that the pump be installed at the highest point within the system to prevent possible water condensate from entering the pump. The pump should be located as closely to its system in order to utilize it most efficiently.

2.42 Pump Environmental Conditions:

The pump is rated for indoor use only. Maximum altitude 2000 meters. Operating temperature range 5°C to 40°C. Maximum relative humidity of 80% for temperatures up to 31°C decreasing to 50% at 40°C. Rated for +/-10% of supply voltage. Pollution Degree 2, Installation Category II.



WARNING

Don't pump flammable or explosive gases or vapors or operate this pump in an atmosphere containing flammable or explosive gases or vapors.

2.50 INTAKE AND DISCHARGE PROVISIONS

2.51 The intake fitting is a NW25-flange / 1/4"NPT. A muffler is supplied for the exhaust.



WARNING

Bursting Hazard- use on exhaust port the silencer or air handling parts suitable for pressures not less than 100 PSIG

Be sure to call Welch technical service prior to start-up at (847) 676-8800 if you have any questions.

2.60 ELECTRICAL POWER

2.61 Power Source Review

Review the power source and the motor rating to be sure they agree in voltage, phase, and frequency. Serious damage may occur to the motor if it is connected to an improper voltage. All Welch pumps must be grounded. Grounding reduces the risk of electric shock in the event of an electrical short circuit. The plug must be plugged into a properly grounded outlet. Consult your local electrical codes if you have doubts.

2.62 Overload Protection

Motor thermal overload protection is made available by the motor manufacturer as an aid to minimize motor failure. Overload protection is a standard feature on both 50 and 60 Hz single-phase-motors. The motors have automatic overload protection. Automatic reset protection is designed to reset itself after a predetermined cooling period. If the fault to the drive remains unaltered, the motor will cycle on and off until the fault is corrected.



WARNING

The motor is thermally protected and will automatically restart unexpectedly when the overload device resets. Don't pump flammable or explosive gases or vapors or operate this pump in an atmosphere containing flammable or explosive gases or vapors.

2.63 Identification Symbols:

○ Power Off | Power On

2.64 Grounding Instructions

This product should be grounded. In the event of an electrical short circuit, grounding reduces the risk of electric shock by providing an escape wire for the electric current. This product is equipped with a cord having a grounding wire with a grounding plug. The plug must be plugged into an outlet that is properly installed and grounded in accordance with all local codes and ordinances.



DANGER

Improper installation of the grounding plug can result in risk of electrical shock

- If repair or replacement of the cord or plug is necessary, do not connect the grounding wire to either flat blade terminal. The wire with insulation having an outer surface that is green with or without yellow stripes is the grounding wire.
- Check with a qualified electrician or serviceman if the grounding instructions are not completely understood, or if in doubt as to whether the product is properly grounded. Do not modify the plug provided; if it will not fit the outlet, have the proper outlet installed by a qualified electrician.
- This product is for use on a nominal 120V circuit, and has a grounding plug that looks like the plug illustrated in Sketch A in Figure #1. A temporary adapter, which looks like the adapter illustrated in sketches Band C, may be used to connect this plug to a 2-pole receptacle as shown in sketch B if a properly grounded outlet is not available.
- The temporary adapter should be used only until a properly grounded outlet (Sketch A) can be installed by a qualified electrician. The green colored rigid ear, lug, etc. extending from the adapter must be connected to a permanent ground such as a properly grounded outlet box cover. Whenever the adapter is used, it must be held in place by a metal screw.

The adapter shown in Figure #1 B and C is not acceptable in Canada.

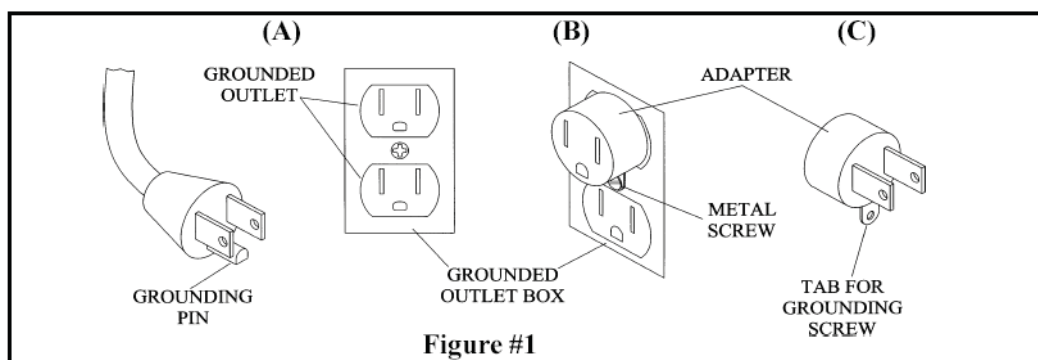

2.65 Extension Cords

Motor thermal overload protection is made available by the motor manufacturer as an aid to minimize motor failure. Overload protection is a standard feature on both 50 and 60 Hz single phase-motors. The motors have automatic overload protection. Automatic reset protection is designed to reset itself after a predetermined cooling period. If the fault to the drive remains unaltered, the motor will cycle on and off until the fault is corrected.

2.70 VACUUM CONNECTIONS

2.71 All Dry Vacuum Pumps come with intake and discharge hose barbs which accept 3/8" ID rubber pressure/vacuum hose. Hose clamps should be used to hold the hose in place. Since all four models operate in the viscous flow regime, the small diameter of the hose will generate minimal conductance loss. For best results, Welch recommends the length of the tubing between the pump and the chamber be kept as small as possible.

2.80 VACUUM GAUGES

2.81 Typical in the rough vacuum range, a dial vacuum gauge is used to measure pressure in mm Hg or Inches of Hg. The dial vacuum gauge gives negative pressure – that is pressure below atmospheric. The reference point for the vacuum gauge is atmospheric pressure. Please keep in mind that atmospheric pressure tends to vary from day to day. As a result of variability, the dial vacuum gauge will indicate slightly different maximum vacuum readings from day to day.

2.90 TRAPS

2.91 The need of a Trap

The pumps will handle humid air. All wetted aluminum parts are treated for corrosion protection from moisture. All other wetted parts are stainless steel. If there is a chance liquid may be drawn from the process under evacuation, Welch recommends a liquid trap be placed between the process and the pump. A simple liquid trap is a filtering flask.

When a heavy load of water vapor is evolved from the vacuum process, a cold trap is recommended to help prevent damage to the pump mechanism. The cold trap, immersed in a suitable Dewar flask, is installed so that the water vapor may come in contact with the surfaces of the trap and condense. Commonly used refrigerants are liquid nitrogen or dry ice and acetone or alcohol. Dry ice provides sufficient cooling to freeze out most heavy water vapor loads. A variety of cold traps are available from Welch.

The symptom of a high water vapor load is if you have droplets coming out of the exhaust port. If you see droplets of water, Welch recommends you use a cold trap to capture the water before entering the pump or dilute the water vapor stream by adding dry nitrogen to the gas flow. Please call our customer service department for additional information at (847) 676-8800.

2.92 The Care of a Trap

When using a cold trap the refrigerant should be maintained at a high level in the flask to keep the trap at a uniformly low temperature. If the trap is rewarmed it may allow re-evaporation of the condensate. The refrigerant add tube on the liquid nitrogen trap should not be obstructed as the refrigerant boil-off can produce dangerously high pressures. If the trap becomes saturated it should be disconnected from the system, drained, and cleaned. An increase in pressure in the vacuum system will normally indicate that the trap has become saturated. To clean the trap, remove the trap from the system and allow the trap to warm up and rinse off the condensate with a suitable solvent in a fume hood. Thoroughly clean and dry the trap before reinstalling into the system.

Section 3: OPERATION

3.10 STARTING PROCEDURES

3.11 Starting A Welch Pressure/Vacuum Pump

Before attaching the pump to a system, familiarize yourself with the function and action of the pressure/vacuum pump that you have acquired. Review the power requirements as described in Section 2.60. Welch recommends running the pump for a few minutes to warm it up, before use. The warm-up improves the pumps ability to handle humid air.

3.12 Cleanliness

Take every precaution to prevent foreign particulates from entering the pump. Particulates will damage the pump's performance. If you find that particulates come off the process during evacuation, a particulate trap in the fore line will work. A simple, inexpensive trap may be made by placing glass wool in a glass or plastic tube. Screens must be inserted to hold the glass wool in place.



WARNING

The pump is not recommended for pumping acid, base or organic vapors or gases. Serious damage to the pump will shorten the pump's service life. In addition, pumping flammable vapors or gases can lead to serious safety hazard leading to fire or explosion.

3.20 LEAK DETECTION

The importance of eliminating all leaks in a vacuum system is obvious. The pump must remove this added volume of leaked gas to maintain the desired vacuum. Leaks for these pump can be located by slightly pressuring the system and painting the suspected area with a thick soap solution. Escaping air will produce soap bubbles.

3.30 PRESSURE RANGE

Vacuum pumps are designed to be run from slightly below atmospheric to their maximum vacuum level on the intake side. The pumps also may be run from atmospheric to their maximum rated pressure rating. Consult the Specification Table (See Section 6, Specifications) for the ratings of your specific model.

3.40 SHUTDOWN PROCEDURES

After use, Welch recommends the pump be run for about 2 minutes disconnected from the vacuum process. The air pumped through the mechanism will purge out water vapor or droplets of water condensate that may have formed on the inside of the pump. This purge of the pump mechanism helps prevent corrosion.

Section 4: MAINTENANCE

4.10 GENERAL MAINTENANCE

Welch dry vacuum pumps are 100% oil-free. The pump employs a non-lube piston and cylinder. No maintenance is necessary for the bearings. All bearings are sealed and permanently lubricated. Lubrication should not be attempted. The units are built for continuous duty operation with the quietness and durability of a diaphragm, but with piston performance.

Section 5: TROUBLESHOOTING

5.10 VACUUM PROBLEMS

Welch dry vacuum pumps are 100% oil-free. The pump employs a non-lube piston and cylinder. Leakage, contamination and unusual outgassing are the general causes of problems with poor vacuum. To operate at maximum efficiency a system must be thoroughly clean. If the system is completely clean and free from leaks, and unwarranted vacuum problems still exist, the pump should be checked. A simple criterion for the condition of the pump is the determination of its maximum vacuum capability. This can be accomplished by blocking of the intake and reading the vacuum level on the gauge (See Section 2.8).

5.20 TROUBLESHOOTING TABLE

Poor Pumping Speed	Poor Vacuum	Loud Unit	Possible Cause	Corrective Action
X	X	X	Damaged valves	Replace flapper valves
X	X	X	Debris in valves	Remove debris and check for valve damage
X	X	X	Damaged gasket	Replace gasket
X	X	X	Loose head screw	Tighten head screw
X	X	X	Loose fitting	Tighten fitting

Section 6: SPECIFICATION

6.10 SPECIFICATION CHART

Welch Model	2563
Free Air Displacement	
CFM (L/min.) @ 60Hz	2.12 (60)
CFM (L/min.) @ 50Hz	1.77 (50)
Ultimate Pressure	
Torr (mbar)	5 (7)
Motor Horsepower	
Horsepower	1/3
Tubing needed	
I.D. in Inches (mm)	1/4 (7)
Shipping Weight	
Weight lbs (Kg)	16.5 (7.5)
Catalog Number	
Catalog Number Wired for 115V, 60Hz, 1Ph with North American Plug	2563B-24
Catalog Number Wired for 220V, 50Hz, 1Ph with European Schuko Plug	2563C-24
Catalog Number Wired for 100V, 50/60Hz, 1Ph with North American Plug	2563C-25

6.20 PUMPING SPEED CURVE

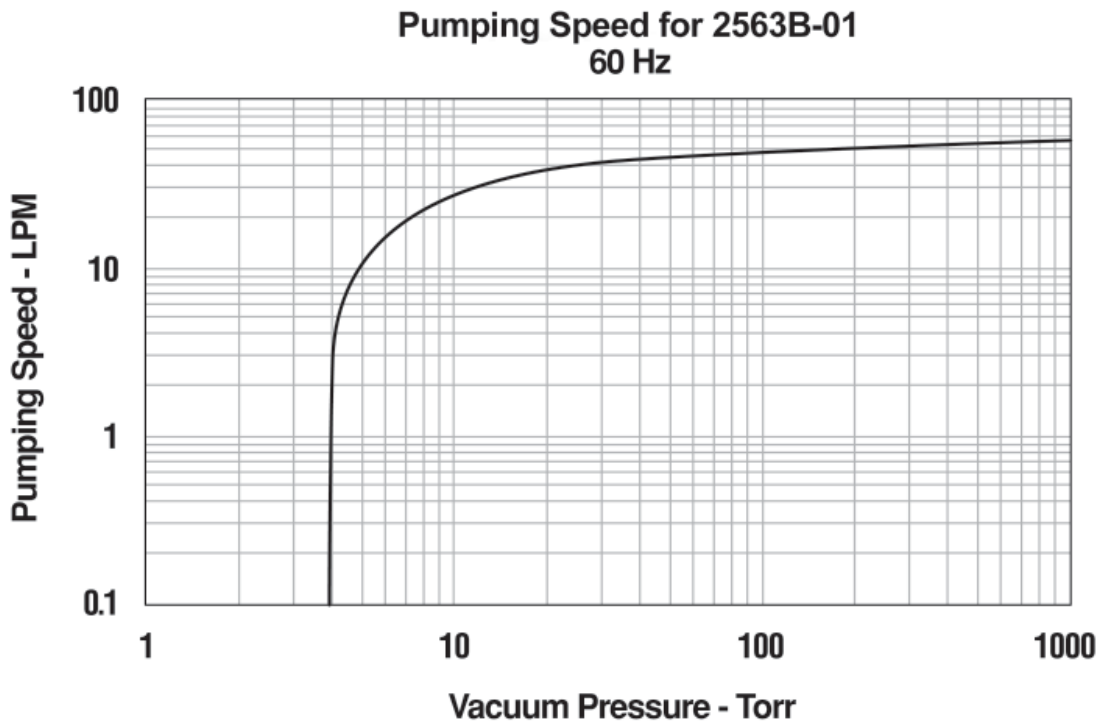

Section 7: WARRANTY

UNPACKING

Inspect the pump carefully. If any damage has occurred, file claim with the carrier immediately. Save the shipping container for carrier to inspect.

OPERATING PUMP

Refer to the enclosed Instruction/Operation Manual for all information to properly operate and maintain the pump.

WARRANTY

This Welch-Illvac Inc. product is warranted to be free from defects in material and workmanship. The liability of Welch-Illvac Inc. under this warranty is limited to servicing, adjusting, repairing or replacing any unit or component part which in the judgment of Welch-Illvac Inc. has not been misused, abused or altered in any way causing impaired performance or rendering it inoperative. No other warranties are expressed or implied. The method of executing this warranty: servicing, adjusting, repairing or replacing shall be at the discretion of Welch-Illvac Inc. Vacuum pumps that have been used for any period, however short, will be repaired under this warranty rather than replaced.

The warranty is effective for one year from the date of original purchase when:

1. The warranty card has been completed and returned.
2. The product is returned to the factory or other designated service centers, freight prepaid.
3. The product in our judgment is defective through no action or fault of the user.

If the product has become defective through misuse, abuse, or alteration, repairs will be billed regardless of the age of the product. In this event, an estimate of the repair costs will be submitted and authorization of these charges will be required before the product is repaired and returned.

To reduce additional charges and delays either within or outside of the warranty period, contact Welch-Illvac Inc. @847-676-8800 for a return authorization number. Products without a return authorization number will be refused by our receiving department. Before shipping, properly pack the pump, insure it against loss or damage, and on the outside of the pump packaging and the packing slip write in the return authorization number. Pumps damaged due to improper packaging are the customer's responsibility.

Section 8: PARTS LIST AND EXPLODED VIEWS

8.10 MODEL 2563 DIMENSIONAL

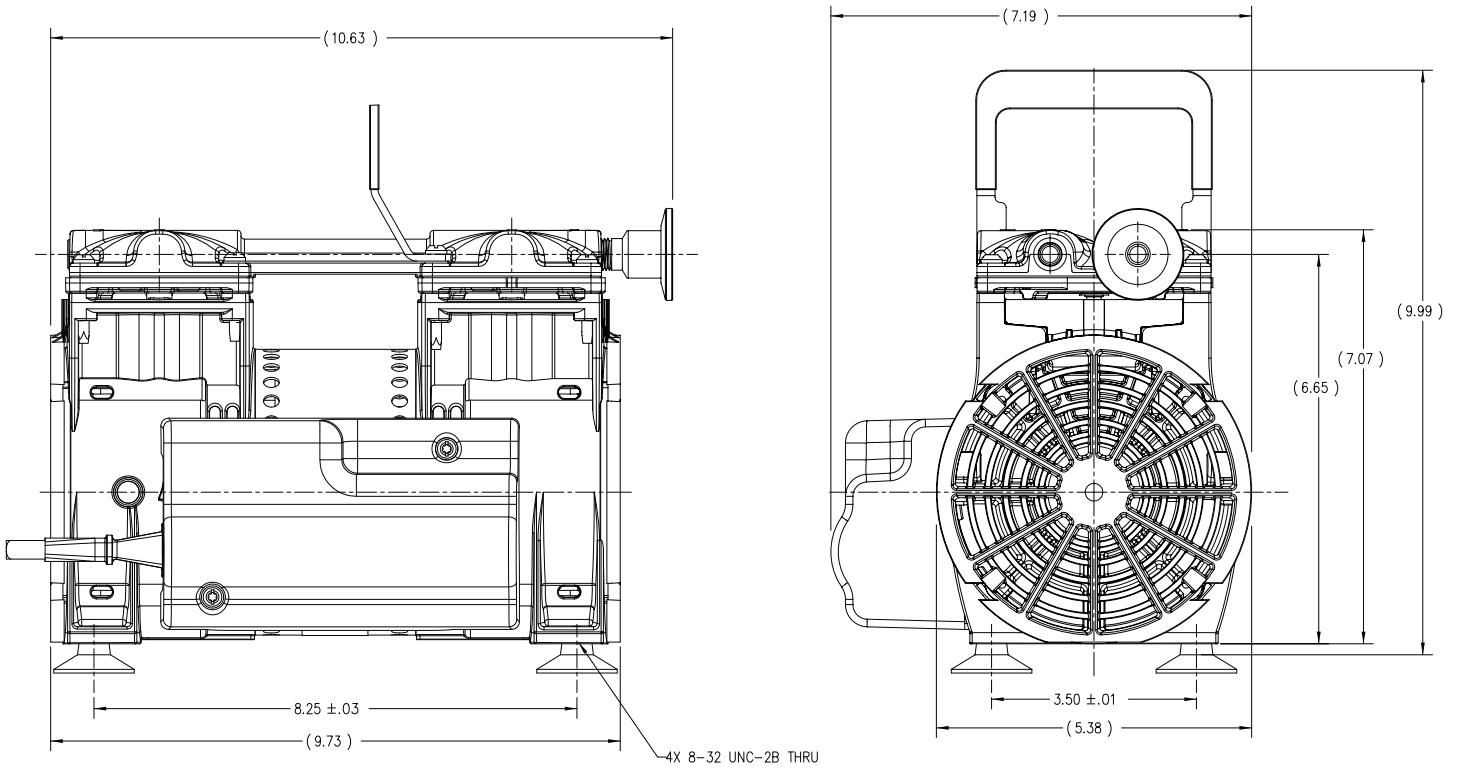

8.20 MODEL 2563 PARTS LIST AND EXPLODED VIEW

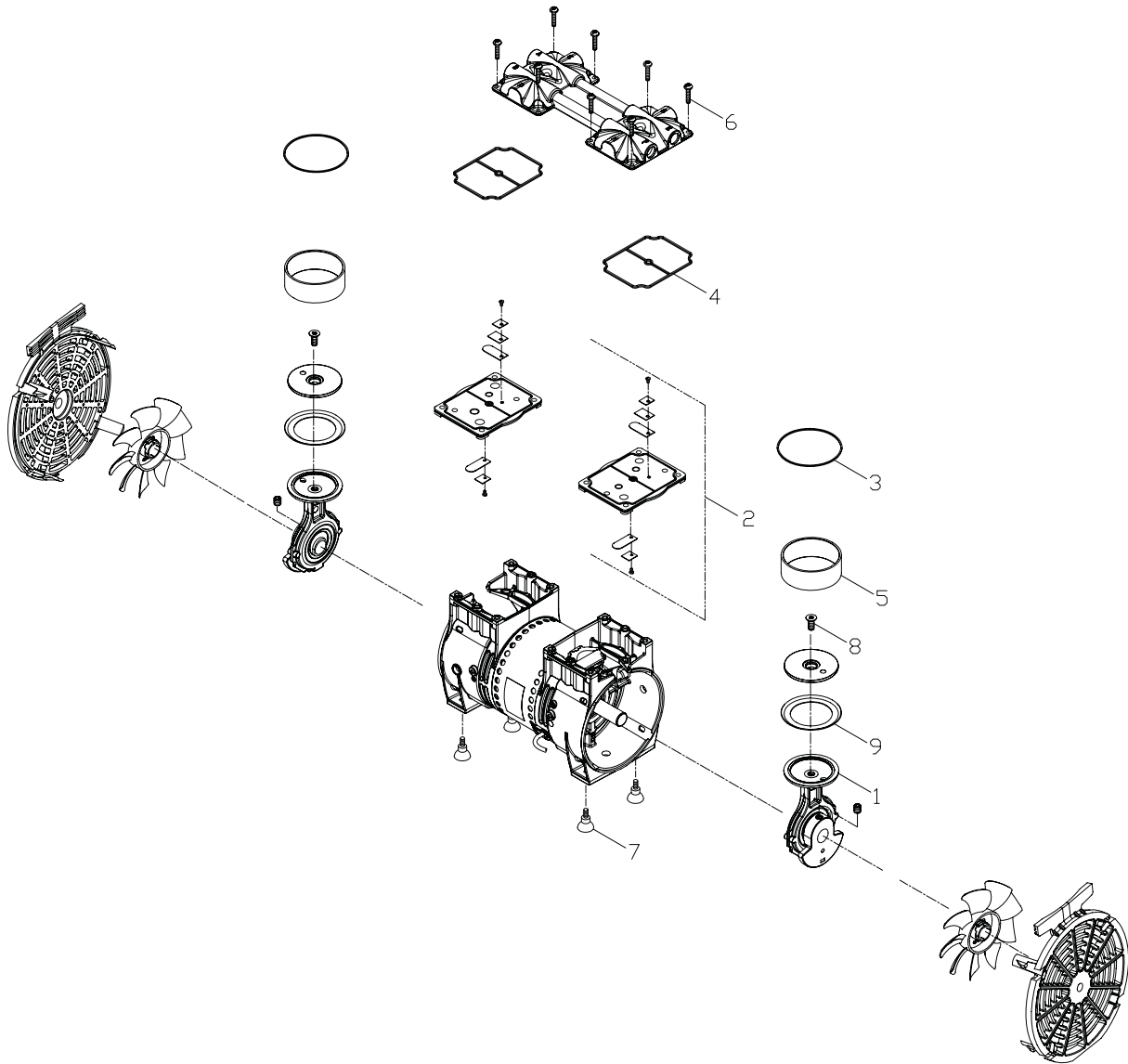

Item No.	Part No.	Description	Service Kit 2563K-03	Gasket Kit 2567K-04	Foot Kit 2500K-04
1	2563K-01**	Connecting Rod Assembly	-	-	-
2	2567K-02	Valve Plate Assembly	2	-	-
3	*	Cylinder O-Ring	2	2	-
4	*	Valve Plate Head Gasket	2	2	-
5	*	Cylinder Sleeve	2	-	-
6	*	Piston Cup - XL9650	2	2	-
7	*	Suction Cup Feet		-	4
8	*	Retainer Hold Down Screw	2	2	-

* These parts are only available in kits.

** These parts should be repaired by qualified service personnel only.

Section 9: APPLICATION INFORMATION

9.10 VACUUM SYSTEM FOR VACUUM CHAMBER, GLOVE BOX, ANNULAR SPACE & TRANSFER LINE

- 2561B-50
- 2561C-50
- 2561C-56

9.20 SYSTEM COMPONENTS*

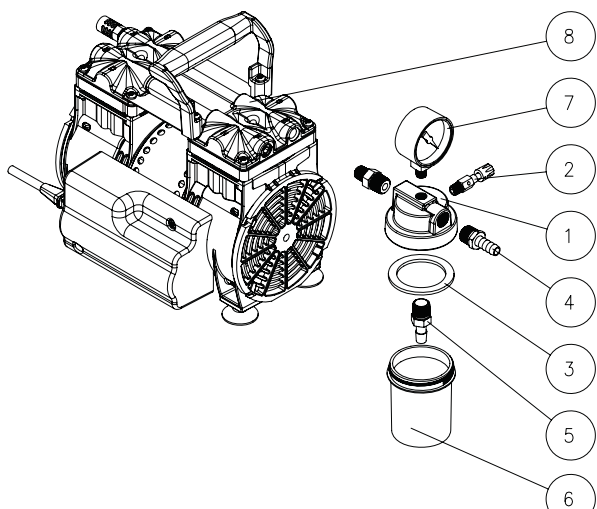

Item No.	Catalog No.	Description
1	-	PTFE Coated Aluminum Lid
2	-	Vacuum Regulator
3	-	PTFE Encapsulated Gasket
4	-	Metal Intake Hose Barb for 3/8" ID Hose
5	-	Kynar Hose Barb
6	1415B	Glass Jar, Inlet Trap
	1415C	Plastic Jar, Inlet Trap
7	726021	Vacuum Gauge, in. Hg, cm Hg
	726024	Vacuum Gauge - mbar/kPa
	726025	Pressure Gauge - psi/kgcm
8	2561B-50	Vacuum System 115V 60Hz 1Ph
	2561C-50	Vacuum System 230V 50/60Hz 1 Ph
	2561C-56	Vacuum System 100V 50/60Hz 1 Ph

9.30 SYSTEM OPERATION

Welch's new portable oil-free general utility roughing pumps provide continuous, reliable vacuum that your vacuum chamber, glove box, annular space and transfer line applications require. The pumping mechanism is an economical twin head oil-free Wob-L® known for reliability and durability. These rugged pumps handle 20,000 plus roughing cycles – from atmospheric to 5 Torr – before needing seal maintenance. The pumps come completely equipped and ready to use. An inlet trap to help prevent ingestion of fluids into the pump, a dial gauge for continuous vacuum level monitoring, and a vacuum regulator to adjust vacuum levels. Just plug it in and you're up and running.

Models 2561B-50, 2561C-50 & 2561C-56 are suited for 1.5 cubic foot ovens or smaller.

The pumping speed of the 2561 at rough vacuum levels is equal to oil-seal rotary vane pumps of similar size. This makes the 2561 an economical, oil-free solution for replacing oil-seal rotary vane pumps. These pumps are therefore highly recommended for standard duty laboratory applications, general vacuum work and where quick roughing of a chamber is needed. The 2561 Pump Models are for use in standard duty applications. This means that they are not recommended for pumping acidic, basics or organic vapors or gasses. If you are looking for a pump to handles these types of conditions, contact a Welch representative and they will be able to assist you in selecting the correct pump for your application.

* System components available as kit Cat. No. 2565K-50

Welch-Ilmvac
5621 W. Howard Street
Niles, IL 60714
Phone: (847) 676-8800 (Technical Support)
Fax: (847) 677-8606
E-Mail: gdwelchvacuum@gardnerdenver.com
Web-Page: www.welchvacuum.com

Copyright© 1997-2007 Gardner Denver Welch Vacuum Technology, Inc.
Welch is registered trademarks of Gardner Denver