



NOTICE: This document contains references to Varian. Please note that Varian, Inc. is now part of Agilent Technologies. For more information, go to [www.agilent.com/chem](http://www.agilent.com/chem).



Agilent Technologies

# ***Wireless Remote Base Unit for VS Series Leak Detectors (VSFLDWB)***

*FIELD INSTALLATION  
INSTRUCTIONS*

Part Number 699910002

Rev. A

October 2006

*This page intentionally left blank.*

# Varian Field Instruction Sheet

## Wireless Remote Base Unit for VS Series Leak Detectors

### Preface

#### Documentation Standards

This manual uses the following documentation standards:

#### NOTE



Notes contain important information.

#### CAUTION



Cautions appear before instructions, which if not followed, could cause damage to the equipment or data loss.

#### WARNING



Warnings appear for a particular procedure or practice which, if not followed correctly, could lead to serious injury or death.

#### Hazard and Safety Information

The common international symbols used in this manual and on the equipment are defined below.



OFF Supply (Power)



Earth (Ground) Terminal



ON Supply (Power)



Caution, Hot Surface



AC – Alternating Current



Caution, Risk of Electrical Shock



Warning, Risk of danger



Protective Conductor Terminal



Frame or chassis Terminal



Operators and service personnel must be aware of all hazards associated with this equipment. They must know how to recognize hazardous and potentially hazardous conditions, and know how to avoid them. The consequences of unskilled, improper, or careless operation of the equipment can be serious. Every operator or service person must read and thoroughly understand operation/maintenance manuals and any additional information provided by Varian. All warning and cautions must be read carefully and strictly observed. Consult local, state, and national agencies regarding specific requirements and regulations. Address any safety, operation, and/or maintenance questions to your nearest Varian office.

**Solvents**

**WARNING**



The mechanical components of leak detectors may be cleaned with one of the recommended solvents. When heated, sprayed, or exposed to high-temperature equipment, these solvents become flammable and explosive, causing serious injury or death. Do not use these solvents near a high-temperature source. Ventilate the working area with a blower and work in a large, well-ventilated room.

Solvents are irritants, narcotics, depressants and/or carcinogens. Their inhalation and/or ingestion may produce serious side effects. Prolonged or continued contact with the skin results in absorption through the skin and moderate toxicity. Always ensure that cleaning operations are carried out in large, well-ventilated rooms, and wear eye shields, gloves, and protective clothing.

Due to the effective cleaning nature of VacuSolv solvent and its residue-free properties, Varian Component and Spectrometer Cleaning Kit (Part Number 670029096), used in accordance with the kit instructions, is recommended for cleaning spectrometer components. The kit can also be used for fine cleaning of other parts in the leak detector's vacuum system such as valves and fittings. No rinsing steps or high-temperature drying is required following cleaning with VacuSolv. Although appropriate precautions are advised, VacuSolv is compatible with most materials and does not contain toxic chemicals or CFCs (chlorofluorocarbons). Other acceptable solvents are isopropyl alcohol (IPA) or Dow Corning® OS-20.

To clean the leak detector plastic enclosure, the LCD display and Front Panel buttons, use only a soft cloth slightly dampened with water or a mild soap.

Do NOT use excess water or cleaning solvents of any kind.

Avoid splashing any cleaning solvents into the unit through the ventilation openings or Front Panel buttons. Wipe the surface with a dry lint-free cloth.

**Vacuum Equipment and Cleanliness**

Cleanliness is vital when servicing the leak detector or any vacuum equipment. There are some techniques that are more important in leak detector servicing than in general vacuum work:

**CAUTION**



Wear non-powdered, ESD-safe Nitride or equivalent gloves to prevent skin oils from getting on spectrometer internal components.

### O-ring Care

When removing, checking or replacing O-rings, keep in mind the following:

#### NOTE



Varian recommends replacing all O-rings during routine maintenance or during any maintenance procedure requiring that O-rings be removed.

#### CAUTION



Remove O-rings carefully with your fingers. Do not use metal tools for this task; this prevents scratching of any sealing surfaces.

- Wipe all O-rings clean with a lint-free cloth before installation to ensure that no foreign matter is present to impair the seal.
- Do not use grease or any other substance on O-rings that will come in contact with the vacuum surfaces.
- Do not use alcohol, methanol or other solvents on O-rings. Doing so causes deterioration and reduces their ability to hold a vacuum.
- Varian does not recommend the use of vacuum grease. If applicable, apply a small amount of Apiezon<sup>®</sup> L grease and wipe the O-rings shiny dry.

### Metal Seal Care

#### CAUTION



Metal Seals must be replaced any time a spectrometer is opened. All fasteners must be installed and torqued per assembly procedure specifications. Remove Metal Seals carefully with your fingers or a soft tool. Metal tools scratch sealing surfaces.

- Metal Seals are supplied in pre-cleaned condition. No cleaning is required. If necessary, Metal Seals can be cleaned using the recommended solvents. Wipe Metal Seals clean with a lint-free cloth before installation to ensure that no foreign matter impairs the seal.
- Do not use grease or any other substance on Metal Seals that will come in contact with the spectrometer.

### Spectrometer

#### CAUTION



Store the Ion Source/Preamplifier sub-assembly in a cool, dry area in a tightly sealed, ESD protected container. Wear non-powdered, ESD-safe Nitride or equivalent gloves when handling the spectrometer. Wash hands thoroughly after handling the spectrometer filaments and especially before smoking or eating.

The spectrometer and PCB's are static sensitive devices. Wear a grounding strap when performing any maintenance on these units and especially when performing maintenance of static sensitive parts.

#### CAUTION



The spectrometer operates at a very high vacuum produced by the high vacuum turbomolecular pump. Service of the spectrometer requires that this vacuum be vented to the atmosphere.

### Equipment Required

- Extended Length M5 Allen Wrench
- Metric Allen Wrench Set
- M3 Philips Head Screw Driver
- Adjustable Wrench

### Installation Procedure

For clarity, some items have been omitted from views.

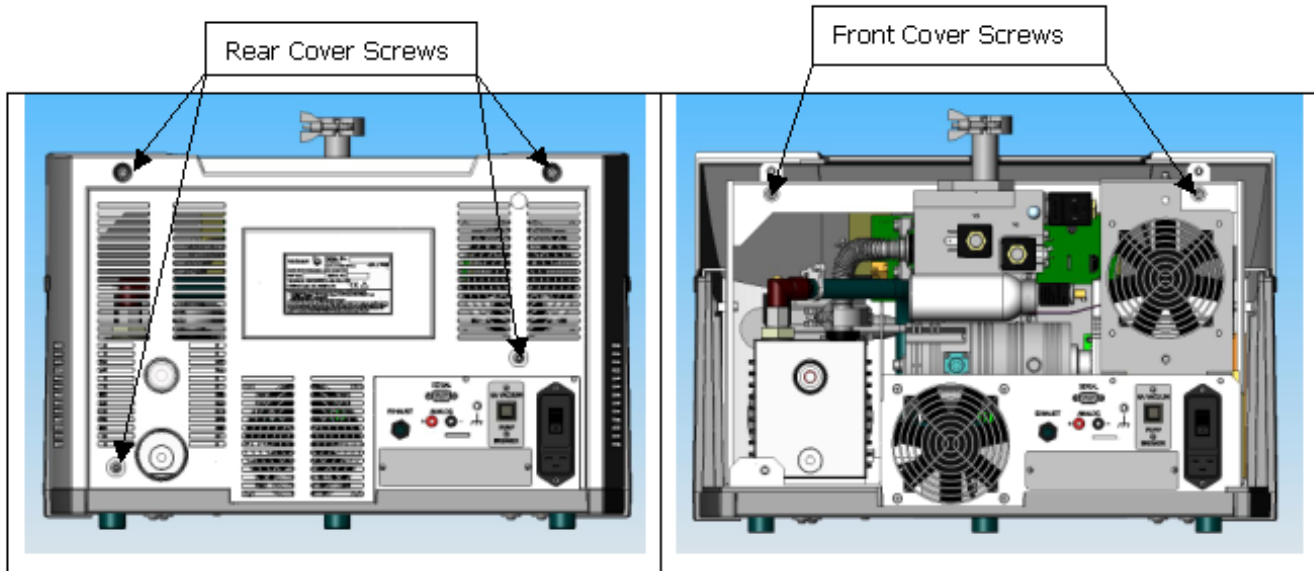


Figure 1: Rear and Front Cover Screws

#### WARNING



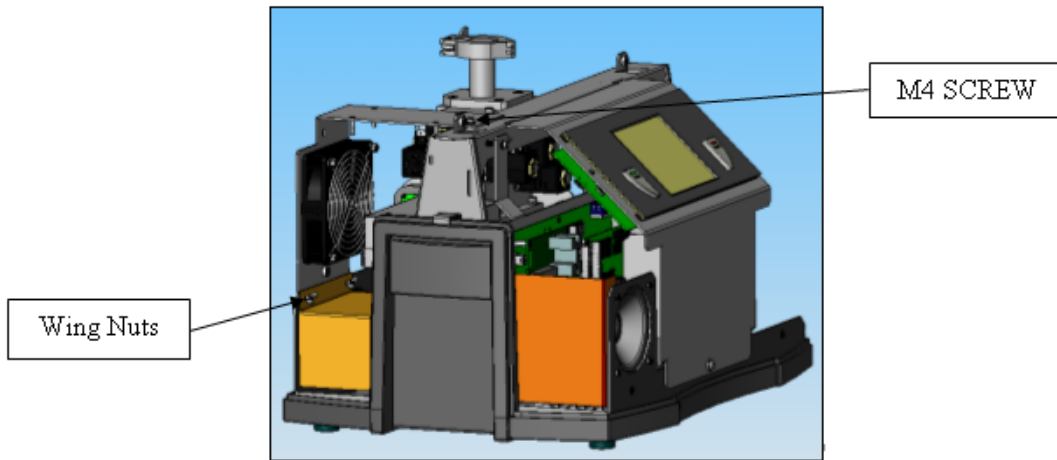
Disconnect power from the unit before performing any maintenance procedure that requires physically disconnecting any part of the system.

#### NOTE



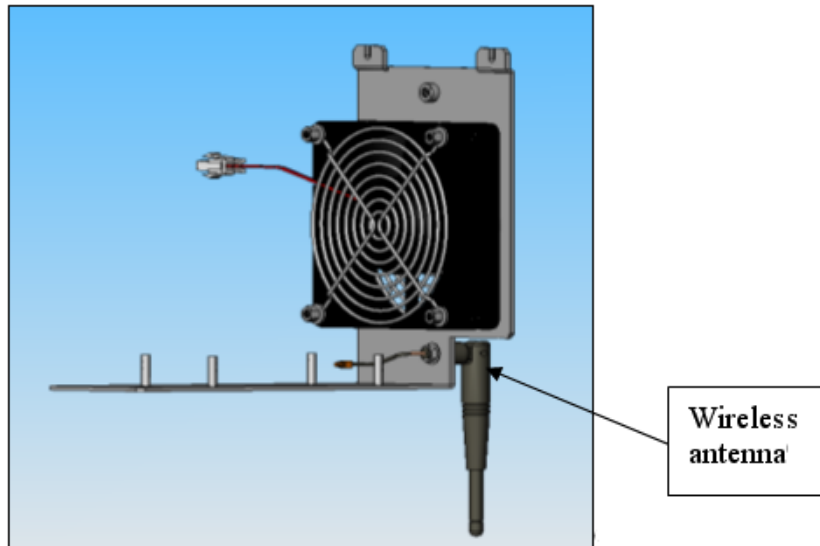
Prior to I/O installation, ensure that the software revision is 2.0 by navigating from the Home screen menu to System Information. If not, contact Varian customer services, see the back cover of this manual for a listing of our sales and service offices.

1. Turn off the power switch located on the back of the unit and unplug.
2. Wait 30 seconds for the high voltage to dissipate.
3. Using an extended length M5 Allen wrench, remove the four screws holding the rear plastic cover (Figure 1: Rear and Front Cover Screws) and detach the rear plastic cover from the unit.
4. Remove the four screws holding the front plastic cover and detach the cover from the unit. Two screws are situated at the front of the unit (not shown) and two screws are positioned inside the unit (Figure 1: Rear and Front Cover Screws).



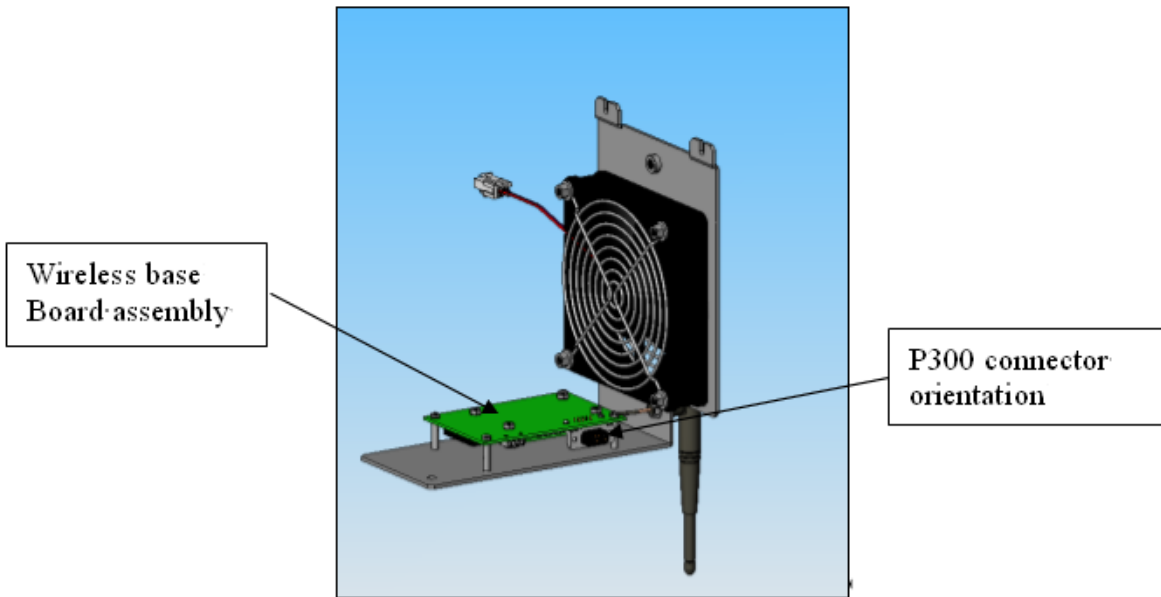
**Figure 2: Fan Assembly and Socket Head Cap Screw**

5. Disconnect the fan connector from the 24 V cable harness.
6. Detach the fan assembly by removing the M4 socket head cap screw and loosening the two wing nuts (Figure 2: Fan Assembly and Socket Head Cap Screw). Place the fan assembly on a flat surface on its back.



**Figure 3: Wireless Antenna**

7. Hand tighten the antenna to the fan bracket, and then apply a ½ turn using an adjustable wrench (Figure 3: Wireless Antenna).



**Figure 4: Base Board Assembly with Posts**

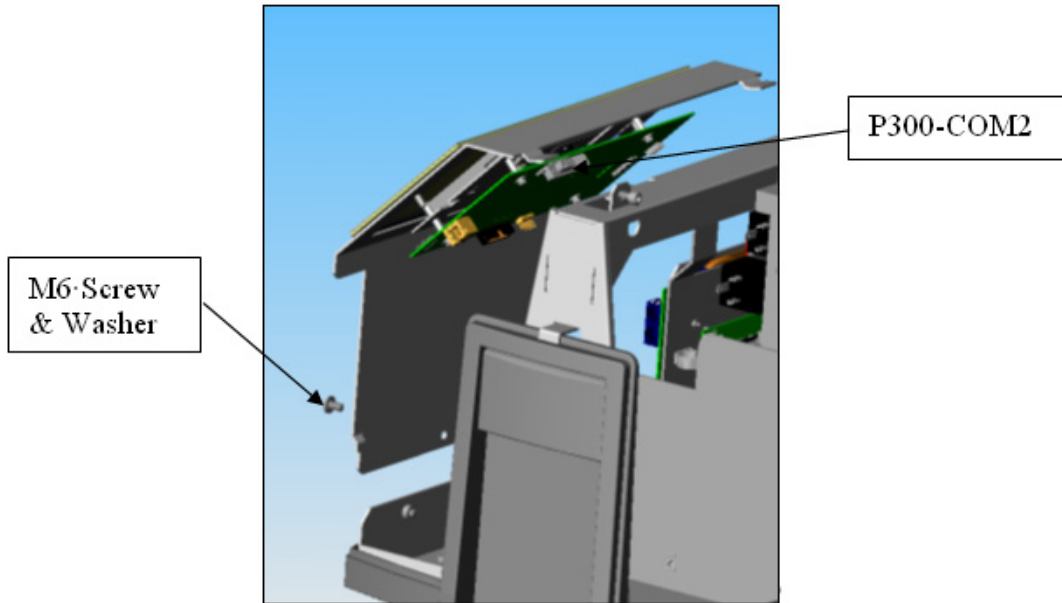
**CAUTION**

**Use proper ESD safety techniques when performing a PCB card install.**



8. Place the wireless board assembly on the four fan bracket standoffs. Note the correct orientation of the wireless base board P300 connector (Figure 4: Base Board Assembly with Posts).
9. Connect the antenna cable to the MMCX jack (Color: gold) on the wireless base board.
10. Secure the wireless base board to the fan bracket using the four M3 Phillips screws provided with the kit.
11. Unfurl the black/red wire (P1-RF) with the 24 V three-pin connector and the ground lug, which is tie rapped at the base of the leak detector, and:
  - Plug the 24 V connector labeled P1-RF into the three-pin connector on the wireless board.
  - Attach the 24 V ground lug to one of the bracket screws.
  - Reinstall the fan assembly by tightening the M4 socket head cap screw and the two wing nuts (Figure 2: Fan Assembly and Socket Head Cap Screw).
12. Connect the RS-232 cable end labeled J300-1 to P300 on the wireless board using its two slotted screws (Figure 4: Base Board Assembly with Posts).

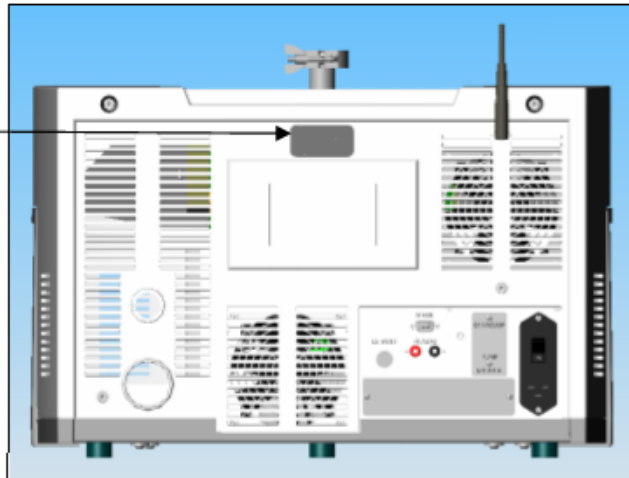




**Figure 5: Front Panel Display**

13. Dress the RS-232 cable through the leak detector to the front panel display.
14. Remove the M6 screw and washer from the front panel display and detach the display (Figure 5: Front Panel Display).
15. Connect the RS-232 cable end labeled J300-2 to P300-COM2 on the front panel display board using its two slotted screws (Figure 5: Front Panel Display).
16. Reattach the display by inserting the tabs into their slotted positions and secure using the M6 screw and washer.
17. Attach the front cover and secure to the frame using existing hardware.
18. Rotate the antenna to its horizontal locked position.
19. Guide the antenna through its location hole in the rear cover. Then secure the rear cover to the frame using existing hardware.

Label



**Figure 6: Label**

20. Attach the label to the rear cover in location shown (Figure 6: Label).
21. Connect the power cord and power up the unit.
22. Watch the home screen to verify the *Spectube Pressure Wait* message progresses to *Stabilization Wait* and *System Ready* within ten minutes.  
Refer to the operator's manual if the system fails to reach the *System Ready* mode.
23. After installation refer to the VS Series leak detector manual (P/N # 699909942) Section 3, for leak detector activation of the wireless remote.
24. Refer to the wireless remote user's manual (P/N # 699909945) for operational instructions.
25. Varian recommends a full calibration of the unit prior to leak test operations.

## Sales and Service Offices

### Canada

#### Central coordination through:

Varian, Inc.  
121 Hartwell Avenue  
Lexington, MA 02421  
USA  
Tel: (781) 861 7200  
Fax: (781) 860 5437  
Toll Free: (800) 882 7426

### China

#### Varian Technologies - Beijing

Room 1201, Jinyu Mansion  
No. 129A, Xuanwumen Xidajie  
Xicheng District  
Beijing 1000031  
P.R. China  
Tel: (86) 10 6608 1031  
Fax: (86) 10 6608 1541

### France and Benelux

#### Varian s.a.

7 avenue des Tropiques  
Z.A. de Courtaboeuf – B.P. 12  
Les Ulis cedex (Orsay) 91941  
France  
Tel: (33) 1 69 86 38 13  
Fax: (33) 1 69 28 23 08

### Germany and Austria

#### Varian Deutschland GmbH

Alsfelder Strasse 6  
Postfach 11 14 35  
64289 Darmstadt  
Germany  
Tel: (49) 6151 703 353  
Fax: (49) 6151 703 302

### India

#### Varian India PVT LTD

101-108, 1st Floor  
1010 Competent House  
7, Nangal Raya Business Centre  
New Delhi 110 046  
India  
Tel: (91) 11 5548444  
Fax: (91) 11 5548445

### Italy

#### Varian, Inc.

Via F.lli Varian, 54  
10040 Leini, (Torino)  
Italy  
Tel (39) 011 997 9 111  
Fax (39) 011 997 9 350

### Japan

#### Varian, Inc.

Sumitomo Shibaura Building, 8th Floor  
4-16-36 Shibaura  
Minato-ku, Tokyo 108  
Japan  
Tel: (81) 3 5232 1253  
Fax: (81) 3 5232 1263

### Korea

#### Varian Technologies Korea, Ltd.

Shinsa 2nd Building 2F  
966-5 Daechi-dong  
Kangnam-gu, Seoul  
Korea 135-280  
Tel: (82) 2 3452 2452  
Fax: (82) 2 3452 2451

### Mexico

#### Varian S.A.

Concepcion Beistegui No 109  
Col Del Valle  
C.P. 03100  
Mexico, D.F.  
Tel: (52) 5 523 9465  
Fax: (52) 5 523 9472

### Russia

#### Central coordination through:

Varian, Inc.  
via F.lli Varian 54  
10040 Leini, (Torino)  
Italy  
Tel: (39) 011 997 9 252  
Fax: (39) 011 997 9 316

### Taiwan

#### Varian Technologies Asia Ltd.

18F-13 No.79, Hsin Tai Wu Road  
Sec. 1, Hsi Chih, Taipei Hsien  
Taiwan, R.O.C.  
Tel: (886) 2 2698 9555  
Fax: (886) 2 2698 9678

### UK and Ireland

#### Varian Ltd.

28 Manor Road  
Walton-On-Thames  
Surrey KT 12 2QF  
England  
Tel: (44) 1932 89 8000  
Fax: (44) 1932 22 8769

### United States

#### Varian, Inc.

121 Hartwell Avenue  
Lexington, MA 02421  
USA  
Tel: (781) 861 7200  
Fax: (781) 860 5437

### Other Countries

#### Varian, Inc.

Via F.lli Varian 54  
10040 Leini, (Torino)  
Italy  
Tel: (39) 011 997 9 111  
Fax: (39) 011 997 9 350

### Customer Support and Service:

#### North America

Tel: 1 (800) 882-7426 (toll-free)  
vtl.technical.support@varianinc.com

#### Europe

Tel: 00 (800) 234 234 00 (toll-free)  
vtl.technical.support@varianinc.com

#### Japan

Tel: (81) 3 5232 1253 (dedicated line)  
vtj.technical.support@varianinc.com

#### Korea

Tel (82) 2 3452 2452 (dedicated line)  
vtk.technical.support@varianinc.com

#### Taiwan

Tel: 0 (800) 051 342 (toll-free)  
vtw.technical.support@varianinc.com

### Worldwide Web Site, Catalog and On-line Orders:

[www.varianinc.com](http://www.varianinc.com)

Representatives in most countries



**VARIAN**