

SOLBERG

**Vacuum Filters
Maintenance Manual
CSL, CT, VS, VL,
SM-CT, CSS, and CBL Series
Metric Version**

Maintenance Manual

SOLBERG Vacuum Filters **CSL, CT, VS, VL, SM-CT, CSS and CBL**

CONTENTS

Section A

Introduction pg. 3

Section B

General Information

1. Identification of Solberg Filters pg. 3
2. Filtration Rules of Thumb pg. 5
3. Element Specifications..... pg. 7
4. Element Cleaning..... pg. 8

Section C

Procedures

1. Installation pg. 8
2. Disconnecting Canister Top from Base..... pg. 8
3. Removing Element for Service/Maintenance. pg. 9
4. Securing Element..... pg. 9
5. Securing Canister Top to Canister Base. pg. 10

Section D

Maintenance Recommendations

1. General..... pg. 10
2. Spare Parts List..... pg. 11

**For Further Information Please Call: +1 630-616-4400*



Section A

INTRODUCTION

The purpose of this manual is instruction on the proper assembly and care of Solberg vacuum inlet filters.

WARNING!

This manual must be read and thoroughly understood before using and caring for this air filter. Failure to comply could result in explosion, product/system contamination or personal injury.

This manual should be used as a supplement to the user's understanding of the proper care needed to maintain a safe and dependable air filter. It is the responsibility of the user to interpret and explain all instructions to persons who do not read or understand English BEFORE they are allowed to maintain and use this filter.

This manual should be readily available to all operators responsible for operation and maintenance of the vacuum inlet filters.

We thank you for selecting products from Solberg Manufacturing, Inc. We are confident that our superior filter designs will exceed your application requirements.

Section B

GENERAL INFORMATION

1. Identification of Solberg Vacuum Inlet Filters.

All Solberg vacuum inlet air filters should have an identification label/nameplate that gives the following information:

Assembly Model #
Replacement Element #

(The exception is OEM supplied units. In this case please enter the OEM part numbers below.)

Page 3

Solberg International, Ltd., 1151 Ardmore Avenue, Itasca IL 60143
Ph: 630/616-4900 Fax: 630/773-0727 Email: sales@solbergmfg.com Web: www.solbergmfg.com
Vacuum Inlet Filters (Metric) March, 2000



SOLBERG

Fill in the actual nameplate data from your new Solberg inlet filter(s):

No.	Filter Model Number	Replacement Element
1		
2		
3		
4		
5		
6		
7		
8		
9		
10		
11		
12		
13		
14		
15		

The model number designates the filter type, the original element configuration and housing connection size. For example, the following part number identifies the filter as being a 'CSL' design filter with a 234 element with prefilter and 3" BSPT connection size:

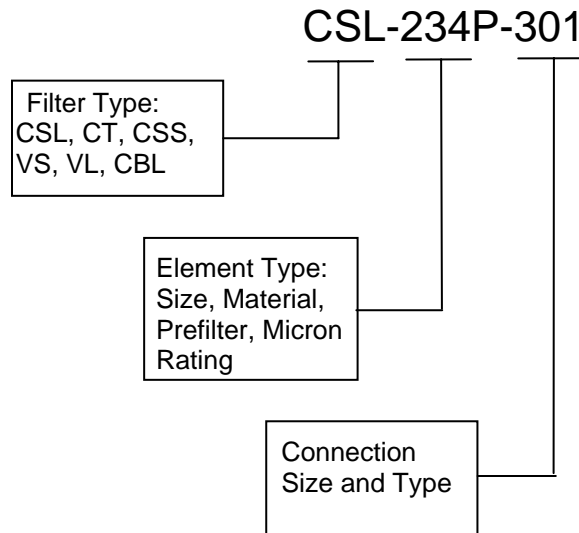

2. Filtration Rules of Thumb

General: For peak output performance from a compressor, blower, vacuum pump, engine, or any other machine that consumes air, one must have clean, unrestricted air. Proper filtration can help stabilize the working environment within rotating equipment even when the external conditions may be quite severe. A critical component in creating the right working conditions is filter sizing. With the properly sized filter, equipment will run smoothly over its entire expected operating life.

A major factor in filtration and filter sizing is air velocity through the filter media. Generally, the slower the velocity of air through a media the higher the filter efficiency and, conversely, the lower the pressure drop. Therefore, the primary goal in filter sizing is to optimize the velocity of air through the media (sometimes called face velocity).

Rule of Thumb #1: Always begin with the filter cartridge requirements when sizing a filter. Once the appropriate element has been selected then move on to the housing requirements.

Rule of Thumb #2: Always ask or specify a filter based on a micron rating **with** filtration efficiencies. As an example, stating a requirement for a 5-micron filter is misleading because no efficiency rating has been specified. A 5-micron filter at 97-% efficiency can be less efficient than a 10-micron filter at 99.7% efficiency. For proper air system performance in light and industrial duty environments, a filter with a minimum of 99.7% filtration efficiency at 10 microns is required.

Rule of Thumb #3: Size your filter correctly by understanding the impact air velocity through a media has on efficiency and pressure drop. Maintain the suggested Air-to-Media ratios listed below based on the external environment listings and Filtration efficiency needs.



Filtration Efficiency Requirements (99+% efficiency)	Environmental Conditions	Air to Media Ratio
<i>Industrial Grade 2-micron Paper</i>	Light Duty (clean, office/warehouse-like)	51 m ³ /h
	Industrial Duty (workshop, factory-like)	25.5 m ³ /h
	Severe Duty (Foundry, Construction-like)	17 m ³ /h
<i>Industrial Grade 5-micron Polyester</i>	Light Duty (clean, office/warehouse-like)	85 m ³ /h
	Industrial Duty (workshop, factory-like)	68 m ³ /h
	Severe Duty (Foundry, Construction-like)	42.5 m ³ /h
<i>Industrial Grade 4-micron Polyester</i>	Industrial Duty (workshop, factory-like)	42.5 m ³ /h
	Severe Duty (Foundry, Construction-like)	25.5 m ³ /h
<i>Industrial Grade 1-micron Polyester</i>	Severe Duty (Foundry, Construction-like)	17 m ³ /h
<i>Industrial Grade 0.3-micron HEPA Glass</i>	Light Duty (clean office/warehouse-like)	17 m ³ /h
	Industrial Duty (workshop, factory-like)	12 m ³ /h
	Severe Duty (Foundry, Construction-like)	8.5 m ³ /h

Rule of Thumb #4: Pressure drop is also caused by the dirt holding capacity of the element. As the element fills up with dirt, the pressure drop increases. It is important to document the pressure drop across a given filter when it is new and then clean or replace it when the pressure drop increases by 250 mm to 380 H₂O from the original reading.

Rule of Thumb #5: The inlet connection greatly influences the overall pressure drop of the filter system. To minimize the restriction contributed by an inlet filter, a velocity of 1,829 m/min or less is suggested through the outlet pipe. The table below lists the suggested flows based on pipe size:



Pipe Size (inches)	Max Airflow	Pipe Size (inches)	Max Airflow	Pipe Size (inches)	Airflow
1/4"	10 m ³ /h	1 1/4"	102 m ³ /h	6"	1870 m ³ /h
3/8"	14 m ³ /h	1 1/2"	136 m ³ /h	8"	3060 m ³ /h
1/2"	17 m ³ /h	2"	230 m ³ /h	10"	5610 m ³ /h
3/4"	34 m ³ /h	2 1/2"	332 m ³ /h	12"	7990 m ³ /h
1"	60 m ³ /h	3"	510 m ³ /h	14"	10200 m ³ /h
		4"	884 m ³ /h		
		5"	1360 m ³ /h		

**Note: This information is for general use only. A qualified engineer must properly design each system.*

3. Element Specifications

Media	Micron Rating	Temperature Range	Filter Change-Out Differential
Standard Paper	99+% @ 2 micron	-26 to 105 C	250-380 mm H ₂ O Over Initial Delta P
Standard Polyester	99+% @ 5 micron	-26 to 105 C	250-380 mm H ₂ O Over Initial Delta P
"N" Series	99+% @ 4 micron	-26 to 105 C	250-380 mm H ₂ O Over Initial Delta P
"Z" Series	99+% @ 1 micron	-26 to 105 C	250-380 mm H ₂ O Over Initial Delta P
HEPA "HE" Series	99.97% @ 0.3 microns	-26 to 105 C	250-380 mm H ₂ O Over Initial Delta P
"U" Series	99+% @ 25 micron	-26 to 105 C	250-380 mm H ₂ O Over Initial Delta P
"W" Series	99+% @ 100 micron	-26 to 105 C	250-380 mm H ₂ O Over Initial Delta P
"S1" Series	Stainless Steel Wire Mesh	-26 to 105 C	250-380 mm H ₂ O Over Initial Delta P
"AC" & "ACP" Series	N/A	-26 to 105 C	250-380 mm H ₂ O Over Initial Delta P
"Y" Series Polypropylene	99+% @ 10 micron	-26 to 105 C	250-380 mm H ₂ O Over Initial Delta P
"MX" & "MXD" Series – Nomex Cloth	99+% @ 10 micron	-26 to 105 C	250-380 mm H ₂ O Over Initial Delta P



4. Element Cleaning

Some types of Solberg inlet filter elements can be cleaned and reused. However, damage can occur to an element during cleaning so it is imperative that care is taken during disassembly, cleaning and re-assembly. Damaged elements can allow particulate bypass, which will damage rotating equipment.

- A. **Polyester Element.** The polyester element may be washed in warm soapy water, vacuumed, gently blown out or replaced. The element should be dry before reinstallation.
- B. **Paper Element.** The paper element may be lightly blown with low pressure air. It is disposable and in most cases should be replaced with a new element.
- C. **Polyurethane Prefilter.** The prefilter may be washed as a sponge or replaced to give the element a longer service life.
- D. **Stainless Steel Wire Mesh Element.** Cleaning instructions similar to polyester, except mild solvents may be used.
- E. **Activated Carbon Element.** Not cleanable
- F. **Polypropylene Element.** Cleaning instructions similar to polyester
- G. **Nomex Cloth Element.** Cleaning instructions similar to polyester

If you are not confident that the integrity of the element was maintained during cleaning, it is recommended that a new element be installed. Also, spare parts such as gaskets, wingnuts and washers can be supplied upon request.

Section C

PROCEDURES

1. Installation.

- A. Maximum inlet gas stream temperature for most Solberg inlet vacuum filter products is 105 degrees C. Temperatures in excess of this could cause damage to elements, media and elastomers.
- B. Direction of flow is typically from the outside of the element to the inside of the element. Most products have arrows indicating direction of flow on inlet and outlet ports.
- C. Ensure that pipe/flange connections are adequately sealed so the potential for leaks is reduced to a minimum.



2. Disconnecting canister top from canister base.

- A. *VS/VL*: Remove V-clamp by loosening Hex Nut or T-bolt and releasing.
- B. *CT/Small CSL/CBL*: Release wire-form clips.
- C. *Large CSL*: Loosen wing-nut or hex head on T-bolts.
- D. *CSS*: Twist upper housing to release.
- E. Lift off canister top.

3. Removing element for service/maintenance.

- A. Remove retaining hex head/wing-nut and washer carefully, and then remove element. Some elements will have a top plate that should also be removed. Note: Model “CSS” elements should be free when housing tops are removed.
- B. Clean sealing surfaces of housing, top & base plates, and element endcaps so that they are free of dirt or any other particulate.

WARNING!

Failure to comply with these instructions may result in system or pump contamination.

4. Securing Element.

- A. Place new or cleaned element evenly on base plate. Be sure element seats properly on base and there is no dirt or particulate present on sealing surfaces.
- B. Place top plate (if necessary) on element by centering on tap bolt.
- C. Secure washer and wing nut to end cap (or top plate) and tap bolt. Element must be tightly secured. Note: DO NOT over tighten!

WARNING!

Defective installation may cause system or pump contamination. Use only genuine Solberg replacement parts.



5. Securing canister top to canister base.

- A. Make sure all surfaces are free from dust and other particulate.
- B. Hemisphere o-ring must rest evenly along canister/casting base o-ring groove.
- C. *VS/VL*: Secure V-clamp by disconnecting hex nut or T-bolt portion and placing V-clamp along the diameter of canister o-ring groove. Fasten T-bolt and secure tightly. **V-CLAMP LEGS MUST REST UNIFORMLY ALONG ENTIRE O-RING GROOVE.**
- D. *CT/Small CSL/CBL*: Hold canister housing against o-ring or sealing ring on main filter head. Re-fasten wire-form clips.
- E. *Large CSL*: Replace housing top plate. Feed T-bolts into corresponding slots and tighten evenly around perimeter. Note: Do NOT over tighten!
- F. *CSS*: Reassemble top housing to bottom housing by aligning tabs and turning into place.

Section D

MAINTENANCE RECOMMENDATIONS

1. Pressure drop readings are recommended to have an effective air filter. Always document initial pressure drop during start-up when element is clean. Replacement cartridge is needed when system experiences 250 mm to 380 mm H₂O higher pressure drop above the initial reading. Refer to page 4 for instructions.
2. Always check replacement cartridge gaskets to insure they are adhered uniformly along the end caps during handling. If not, contact Solberg Manufacturing, Inc. immediately. Do not modify or change from Solberg specified parts!
3. Always check inlets/outlets, element base and its components when replacing element to insure cleanliness. Wipe clean if necessary.
4. Operate only when a proper seal exists.
5. *VS/VL*: Never operate without absolute assurance that V-clamp is secured correctly along entire diameter of canisters. Check along V-clamp for wear. Replace if any distortion occurs due to handling and usage.



SPARE PARTS LIST: CSL, CT, VS, VL, CSS, AND CBL

Parent Model Model-Element-Connection	Prefilter Model	Housing						Element		
		Top Model No.	O-Ring Model No.	Gasket(s)/ Adapter Model No.	Wingnut(s) Model No.	Washer(s) Model No.	Clips/ Bolts Model No.	Top Plate Model No.	Wingnuts/ Bolt Model No.	Washer(s) Model No.
CSL-825/824-xxx	N/A	T824	OR337	BG224	N/A	N/A	CPWF	N/A	N/A	N/A
CSL-843/842-xxx	PF842	T842	OR550	BG268	N/A	N/A	CPWF	N/A	N/A	N/A
CSL-849/848-xxx	PF848	T848	OR675	BG281	N/A	N/A	CPWF	N/A	N/A	N/A
CSL-851/850-xxx	PF850	T850	OR750	BG412	N/A	N/A	CPWF	N/A	N/A	N/A
CSL-239/238-xxx	PF238	TD238	OR1250	N/A	N/A	N/A	CPWF	N/A	WN38X16	WR38X16
CSL-235/234-xxx	PF234	TC1400	OR1200	N/A	WN38X16	WR38X16	BT38163	T8000437	WN38X16	WR38X16
CSL-335/334-xxx	PF334	TC1400	OR1200	ADEX300	WN38X16	WR38X16	BT38163	T8000437	WN38X16	WR38X16
CSL-245/244-xxx	PF244	TC1850	OR1600	N/A	WN38X16	WR38X16	BT38163	T1000437	WN38X16	WR38X16
CSL-345/344-xxx	PF344	TC1850	OR1600	ADEX300	WN38X16	WR38X16	BT38163	T1000437	WN38X16	WR38X16
CSL-275/274-xxx	PF274	TC1850	OR1600	N/A	WN38X16	WR38X16	BT38163	T12000437	WN38X16	WR38X16
CSL-375/374-xxx	PF374	TC1850	OR1600	ADEX300	WN38X16	WR38X16	BT38163	T12000437	WN38X16	WR38X16
CSL-377/376-xxx	PF376	TC2250	OR2000	N/A	WN38X16	WR38X16	BT38163	T14750625	HN50X13	WR50X13
CSL-384(2)-xxx	PF384(2)	N/A	OR2400	N/A	WN38X16	WR38X16	BT38163	T19750625	HN50X13	WR50X13
CSL-685-xxx	PF684	N/A	OR2400	N/A	WN38X16	WR38X16	BT38163	T19750625	HN50X13	WR50X13
CSL-485(2)/484(2)-xxx	PF484(2)	N/A	OR2400	N/A	WN38X16	WR38X16	BT38163	T19750625	HN50X13	WR50X13
CT-851/850-xxx	PF850	N/A	OR725	BG412	N/A	N/A	CPWF	N/A	N/A	N/A
CT-235/234-xxx	PF234	N/A	GCT1100	ADCT234	N/A	N/A	CPWF	T8000437	BH38X16	WR38X88
CT-275/274-xxx	PF274	N/A	OR386	ADCT234	N/A	N/A	KITCT274	T12000437	BH38450	WR38X16
VS-275/274-xxx	PF274	N/A	OR386	N/A	N/A	N/A	N/A	T12000437	WN38X16	WR38X16
VL-275/274-xxx	PF274	N/A	OR386	N/A	N/A	N/A	N/A	T12000437	WN38X16	WR38X16

*Note: Spare parts are for standard products. See page 4 for replacement element.

