



SOLBERG



Inlet Vacuum Filters Maintenance Manual

www.solbergmfg.com

Note: Please read the maintenance instructions given by the OEM for the machinery first. The OEM's manual should be adhered to in order to protect the equipment. Solberg Manufacturing, Inc has made every effort to make sure that these instructions are accurate but is not responsible for any typos, slight variations or for human errors that may occur.

Maintenance Manual

SOLBERG Inlet Vacuum Filters

CONTENTS

Section A

Introduction pg. 3

Section B

General Information

1. Identification of Solberg Filters pg. 3
2. Filtration Rules of Thumb pg. 4
3. Element Specifications..... pg. 6
4. Element Cleaning..... pg. 7

Section C

Procedures

1. Installation pg. 8
2. Disconnecting Canister Top from Base pg. 8
3. Removing Element for Service/Maintenance. pg. 8
4. Securing Element..... pg. 9
5. Securing Canister Top to Canister Base. pg. 9

Section D

Maintenance Recommendations

1. General..... pg. 10
2. Spare Parts List..... pg. 10

**For Further Information Please Call: 630-773-1363*

Page 2

Solberg Manufacturing, Inc., 1151 Ardmore Itasca, IL 60143 USA
Ph: 630.773.1363 Fax: 630.773.0727 Email: sales@solbergmfg.com Web: www.solbergmfg.com
Rev: MMVF-910



SOLBERG

Section A

INTRODUCTION

The purpose of this manual is instruction on the proper assembly and care of Solberg inlet vacuum filters.

WARNING

This manual must be read and thoroughly understood before using and caring for this air filter. Failure to comply could result in explosion, product/system contamination or personal injury.

This manual should be used as a supplement to the user's understanding of the proper care needed to maintain a safe and dependable air filter. It is the responsibility of the user to interpret and explain all instructions to persons who do not read or understand English BEFORE they are allowed to maintain and use this filter.

This manual should be readily available to all operators responsible for operation and maintenance of the vacuum inlet filters.

We thank you for selecting products from Solberg Manufacturing, Inc. We are confident that our superior filter designs will exceed your application requirements.

Section B

GENERAL INFORMATION

1. Identification of Solberg Vacuum Inlet Filters.

All Solberg inlet vacuum air filters should have an identification label/nameplate that gives the following information:

Assembly Model #
Replacement Element #

(The exception is OEM supplied units. In this case please enter the OEM part numbers below.)

Page 3

Solberg Manufacturing, Inc., 1151 Ardmore Itasca, IL 60143 USA
Ph: 630.773.1363 Fax: 630.773.0727 Email: sales@solbergmfg.com Web: www.solbergmfg.com
Rev: MMVF-910



SOLBERG

Fill in the actual nameplate data from your new Solberg inlet filter(s):

No.	Filter Model Number	Replacement Element
1		
2		
3		
4		
5		

Table 1

The model number designates the filter type, the original element configuration and housing connection size. For example, the following part number identifies the filter as being a 'CSL' design filter with a 235 element with prefilter and 3" MPT connection size:

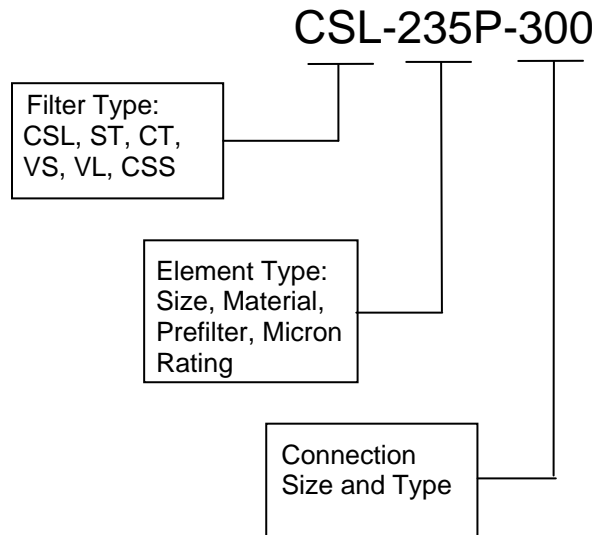

2. Filtration Rules of Thumb

General: For peak output performance from a compressor, blower, vacuum pump, engine, or any other machine that consumes air, one must have clean, unrestricted air. Proper filtration can help stabilize the working environment within rotating equipment even when the external conditions may be quite severe. A critical component in creating the right working conditions is filter sizing. With the properly sized filter, equipment will run smoothly over its entire expected operating life.

A major factor in filtration and filter sizing is air velocity through the filter media. Generally, the slower the velocity of air through a media the higher the filter efficiency and, conversely, the lower the pressure drop. Therefore, the primary



goal in filter sizing is to optimize the velocity of air through the media (sometimes called face velocity).

Rule of Thumb #1: Always begin with the filter cartridge requirements when sizing a filter. Once the appropriate element has been selected then move on to the housing requirements.

Rule of Thumb #2: Always ask or specify a filter based on a micron rating **with** filtration efficiencies. As an example, stating a requirement for a 1-micron filter is misleading because no efficiency rating has been specified. A 1-micron filter at 95-% efficiency may be less efficient than a 5-micron filter at 99% efficiency. For proper air system performance in light and industrial duty environments, a filter with a minimum of 99% filtration efficiency at 5 microns is required.

Rule of Thumb #3: Size your filter correctly by understanding the impact air velocity through a media has on efficiency and pressure drop. Maintain the suggested Air-to-Media ratios listed below based on the external environment listings and Filtration efficiency needs.

Filtration Efficiency Requirements (99+% efficiency)	Environmental Conditions	Air to Media Ratio	
		CFM/ft ²	(m ³ /h)/cm ²
<i>Industrial Grade</i> 2-micron Paper	Industrial Duty (clean, office/warehouse-like)	30 CFM/ft ²	(51m ³ /h)/cm ²
	Severe Duty (workshop, factory-like)	15 CFM/ft ²	(25.5m ³ /h)/cm ²
	Extreme Duty (Foundry, Construction-like)	10 CFM/ft ²	(17m ³ /h)/cm ²
<i>Industrial Grade</i> 5-micron Polyester	Industrial Duty (clean, office/warehouse-like)	50 CFM/ft ²	(85m ³ /h)/cm ²
	Severe Duty (workshop, factory-like)	40 CFM/ft ²	(68m ³ /h)/cm ²
	Extreme Duty (Foundry, Construction-like)	25 CFM/ft ²	(42.5m ³ /h)/cm ²
<i>Industrial Grade</i> 1-micron Polyester	Severe Duty (Foundry, Construction-like)	10 CFM/ft ²	(17m ³ /h)/cm ²
<i>Industrial Grade</i> 0.3-micron HEPA Glass @ 99.97% efficiency	Industrial Duty (clean office/warehouse-like)	10 CFM/ft ²	(17m ³ /h)/cm ²
	Severe Duty (workshop, factory-like)	7 CFM/ft ²	(12m ³ /h)/cm ²
	Extreme Duty (Foundry, Construction-like)	5 CFM/ft ²	(8.5m ³ /h)/cm ²

Table 2



Rule of Thumb #4: Pressure drop is also caused by the dirt holding capacity of the element. As the element fills up with dirt, the pressure drop increases. It is important to document the pressure drop across a given filter when it is new and then clean or replace it when the pressure drop increases by 10" to 15" / 250-380mm H₂O from the original reading.

Rule of Thumb #5: The inlet connection greatly influences the overall pressure drop of the filter system. To minimize the restriction contributed by an inlet filter, a velocity of 6,000 ft/min (10200m³/h) or less is suggested through the outlet pipe. The table below lists the suggested flows based on pipe size:

Pipe Size (inches)	Max Airflow		Pipe Size (inches)	Max Airflow		Pipe Size (inches)	Airflow	
1/4"	6 CFM	10m ³ /h	1 ¼"	60 CFM	102m ³ /h	6"	1,100 CFM	1870m ³ /h
3/8"	8 CFM	14m ³ /h	1 ½"	80 CFM	136m ³ /h	8"	1,800 CFM	3060m ³ /h
1/2"	10 CFM	17m ³ /h	2"	135 CFM	230m ³ /h	10"	3,300 CFM	5610m ³ /h
3/4"	20 CFM	34m ³ /h	2 ½"	195 CFM	332m ³ /h	12"	4,700 CFM	7990m ³ /h
1"	35 CFM	60m ³ /h	3"	300 CFM	510m ³ /h	14"	6,000 CFM	10200m ³ /h
			4"	520 CFM	884m ³ /h			
			5"	800 CFM	1360m ³ /h			

Table 3 **Note: This information is for general use only. A qualified engineer must properly design each system.*

3. Element Specifications

Temperature Range: -15° to 220°F / -26° to 105°C

Filter Change-Out Differential: 10" to 15" / 250-380mm H₂O Over Initial Delta P

Media	Micron Rating
Standard Paper	99+% @ 2 micron
Standard Polyester	99+% @ 5 micron
"S" Series Wire Mesh	Epoxy Coated Wire Mesh
"Z" Series Polyester	99+% @ 1 micron
"HE" Series HEPA	99.97% @ 0.3 microns
"U" Series Polyester	99+% @ 25 micron
"W" Series Polyester	99+% @ 100 micron
"S2" Series	Stainless Steel Wire Mesh
"AC" & "ACP" Series	N/A
"Y" Series Polypropylene	99+% @ 5 micron

Table 4



Temperature Range: -15° to 385°F / -26° to 196°C

Filter Change-Out Differential: 10" to 15" / 250-380mm H₂O Over Initial Delta P

Media	Micron Rating
"MX" & "MXD" Series – Nomex Cloth	99+% @ 5 micron

Table 5

4. Element Cleaning - Inlet Filtration

Solberg elements should be cleaned or replaced, once the pressure drop reaches 15 to 20-inches water column (380 - 500mm WC) above the initial pressure drop of the installation.

The decision to clean the element rather than replace it is left to the discretion of the operator. Any damage which results from by-pass or additional pressure drop created by element cleaning is the sole responsibility of the operator.

WARNING

The overall performance of a filter element is altered once cleaned.

The initial pressure drop after cleaning will be greater than the original, clean pressure drop of the element.

After each subsequent cleaning, the initial pressure drop will continue to increase.

Under all circumstances, the initial pressure drop of the element needs to be maintained at less than 20-inches water column (500mm WC).

Cleaned elements that exceed 20-inches water column (500mm WC) at start-up should be replaced with new elements.

With many types of equipment, the maximum pressure drop allowed will be dictated by the ability of the equipment to perform to its rated capacity. Under all

Page 7

Solberg Manufacturing, Inc., 1151 Ardmore Itasca, IL 60143 USA

Ph: 630.773.1363 Fax: 630.773.0727 Email: sales@solbergmfg.com Web: www.solbergmfg.com

Rev: MMVF-910



SOLBERG

circumstances, the operator should avoid exceeding the manufacturer's recommended maximum pressure drop for their specific equipment.

- A. **Polyester Element.** The polyester element may be washed in warm soapy water, vacuumed, gently blown out or replaced. The element should be dry before reinstallation. The element should be replaced after a maximum of three cleanings.
- B. **Paper Element.** The paper element may be lightly blown with low pressure air. It is disposable and in most cases should be replaced with a new element.
- C. **Polyurethane Prefilter.** The prefilter may be washed as a sponge or replaced to give the element a longer service life.
- D. **Epoxy Coated Wire Mesh and Stainless Steel Wire Mesh Elements:** Cleaning instructions similar to polyester, except mild solvents may be used.
- E. **Activated Carbon Element.** Not cleanable
- F. **Polypropylene Element.** Cleaning instructions similar to polyester
- G. **Nomex Cloth Element.** Cleaning instructions similar to polyester

If you are not confident that the integrity of the element was maintained during cleaning, it is recommended that a new element be installed. Also, spare parts such as gaskets, wing nuts and washers can be supplied upon request.

Section C

PROCEDURES

1. Installation.

- A. Maximum inlet gas stream temperature for most Solberg inlet vacuum filter products is 220°F / 105°C. Temperatures in excess of this could cause damage to elements, media and elastomers.
- B. Direction of flow is typically from the outside of the element to the inside of the element. Most products have arrows indicating direction of flow on inlet and outlet ports.
- C. Ensure that pipe/flange connections are adequately sealed so the potential for leaks is reduced to a minimum.

2. Disconnecting canister top from canister base.

- A. ST/CT/Small CSL: Release wire-form clips or loosen wing nut on "claw" bolts.



- B. Large CSL: Loosen wing nut or hex head on T-bolts.
- C. CSS: Twist upper housing to release.
- D. VS/VL: Remove V-clamp by loosening Hex Nut or T-bolt and releasing.
- E. Lift off canister top.

3. Removing element for service/maintenance.

- A. Remove retaining hex head/wing-nut and washer carefully, and then remove element. Some elements will have a top plate that should also be removed.
- B. Clean sealing surfaces of housing, top & base plates, and element endcaps so that they are free of dirt or any other particulate.

WARNING

Failure to comply with these instructions may result in system or pump contamination.

4. Securing Element.

- A. Place new or cleaned element evenly on base plate. Be sure element seats properly on base and there is no dirt or particulate present on sealing surfaces.
- B. Place top plate (if necessary) on element by centering on tap bolt.
- C. Secure washer and wing nut to end cap (or top plate) and tap bolt. Element must be tightly secured. Note: DO NOT over tighten!

WARNING

Defective installation may cause system or pump contamination. Use only genuine Solberg replacement parts.

5. Securing canister top to canister base.

- A. Make sure all surfaces are free from dust and other particulate.

Page 9

*Solberg Manufacturing, Inc., 1151 Ardmore Itasca, IL 60143 USA
Ph: 630.773.1363 Fax: 630.773.0727 Email: sales@solbergmfg.com Web: www.solbergmfg.com
Rev: MMVF-910*



SOLBERG

- B. Hemisphere o-ring must rest evenly along canister/casting base o-ring groove.
- C. ST/CT/Small CSL: Hold canister housing against o-ring or sealing ring on main filter head. Re-fasten wire-form clips or “claw” bolts.
- D. Large CSL: Replace housing top plate. Feed T-bolts into corresponding slots and tighten evenly around perimeter. Note: Do NOT over tighten!
- E. VS/VL: Secure V-clamp by disconnecting hex nut or T-bolt portion and placing V-clamp along the diameter of canister o-ring groove. Fasten T-bolt and secure tightly. V-CLAMP LEGS MUST REST UNIFORMLY ALONG ENTIRE O-RING GROOVE.
- F. CSS: Reassemble top housing to bottom housing by aligning tabs and turning into place.

Section D

MAINTENANCE RECOMMENDATIONS

1. Pressure drop readings are recommended to have an effective air filter. Always document initial pressure drop during start-up when element is clean. Replacement cartridge is needed when system experiences 10” to 15” / 250-380mm H₂O higher pressure drop above the initial reading. Refer to page 4 for instructions.
2. Always check replacement cartridge gaskets to insure they are adhered uniformly along the end caps during handling. If not, contact Solberg Manufacturing, Inc. immediately. Do not modify or change from Solberg specified parts!
3. Always check inlets/outlets, element base and its components when replacing element to insure cleanliness. Wipe clean if necessary.
4. Operate only when a proper seal exists.
5. VS/VL: Never operate without absolute assurance that V-clamp is secured correctly along entire diameter of canisters. Check along V-clamp for wear. Replace if any distortion occurs due to handling and usage.

SPARE PARTS

Contact your Solberg Representative for spare part model numbers.

