



HiScroll 18, Scroll Pump, Standard, incl. pressure sensor



Similar Image

HiScroll 18, Scroll Pump, Standard, incl. pressure sensor

- No hydrocarbons: Completely dry & oil-free Scroll vacuum pump
- Low noise level, minimal vibrations and compact design, ideal also for use in laboratories
- Safe operation due to the installed non-return valve and hermetically sealed pumping system
- Low operating costs thanks to the highest quality, short maintenance times and long maintenance intervals
- Power as required: Stable pumping speed and short cycle times
- Sustainable: 15% higher efficiency of the drive system, reduced heat generation and minimum cooling requirements
- Comfort and efficiency: Stand-by mode and automatic pressure regulation through rotation speed control with integrated pressure sensor
- Industry 4.0 compatible: Operation with other intelligent products, such as turbopumps via RS-485
- Simple logistics: Our HiScroll pumps are suitable for all voltages worldwide

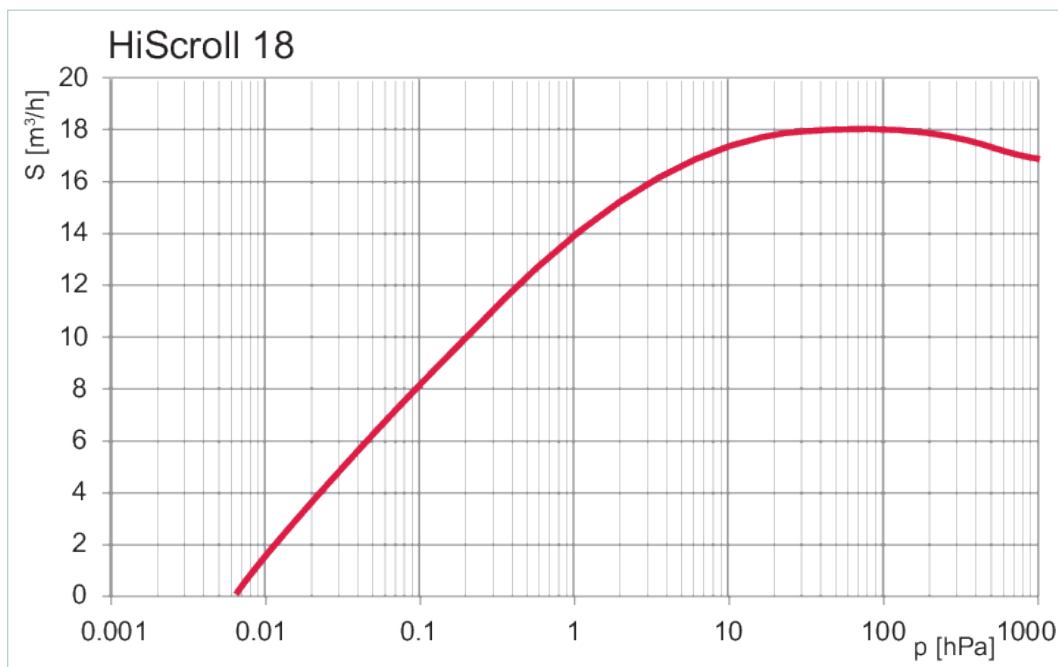

Dimensions

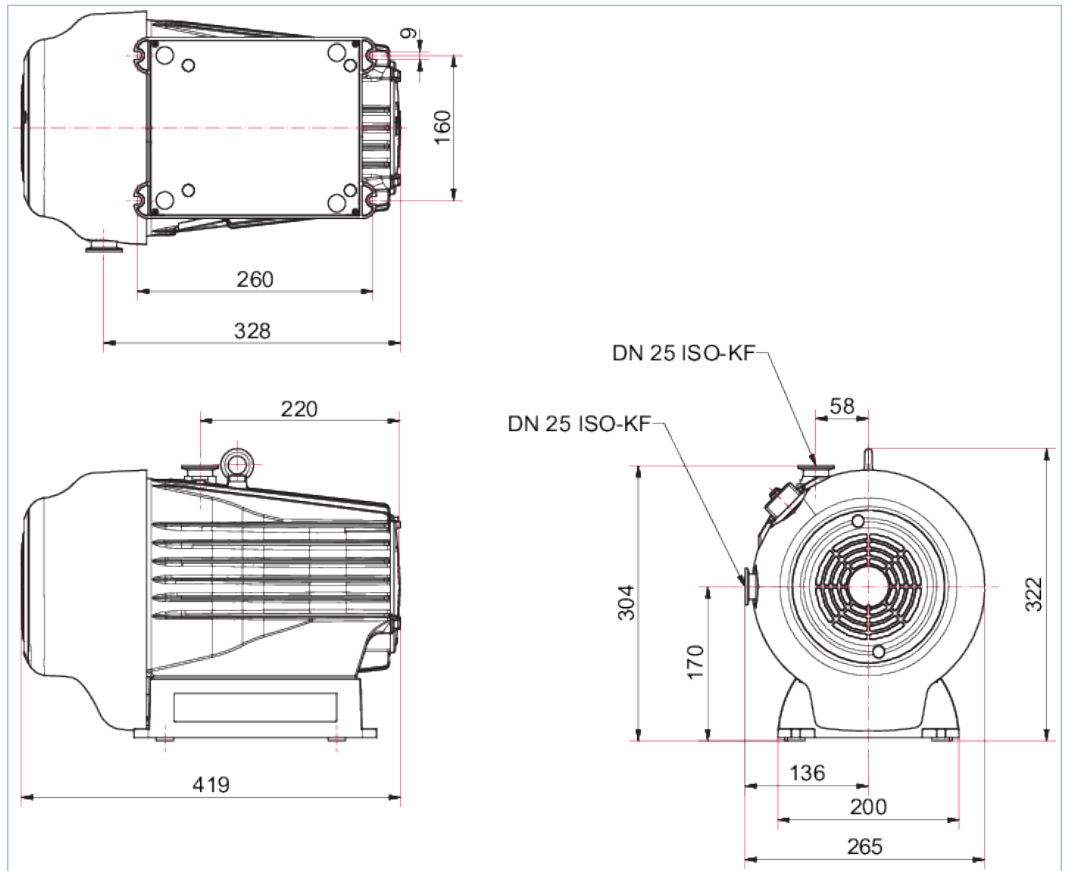

Technical Data	HiScroll 18, Scroll Pump, Standard, incl. pressure sensor
Pumping speed	18.1 m ³ /h 10.65 cfm 301.67 l/min
Final pressure without gas ballast	7 · 10 ⁻³ hPa 5.25 · 10 ⁻³ Torr 7 · 10 ⁻³ mbar
Gas ballast flow stage 1	23 l/min
Gas ballast flow stage 2	30 l/min
Leak rate	5 · 10 ⁻⁷ Pa m ³ /s 3.75 · 10 ⁻⁶ Torr l/s 5 · 10 ⁻⁶ mbar l/s
Intake pressure max.	1,100 hPa 825 Torr 1,100 mbar
Exhaust pressure, max.	1,500 hPa 1,125 Torr 1,500 mbar
Connection flange (in)	DN 25 ISO-KF
Connection flange (out)	DN 25 ISO-KF
I/O interfaces	RS-485
Mains connection	100 — 127 / 200 — 240 V AC (±10 %), 50/60 Hz
Rated current consumption	100 V – 127 V: 10 A 200 V – 240 V: 6 A
Rotation speed	624-1,560 rpm 624-1,560 min ⁻¹
Protection category	IP20
Switch	Yes
Ambient temperature	5-40 °C 41-104 °F 278-313 K
Temperature: Storage	-10-50 °C 14-122 °F 263-323 K
Cooling method, standard	Air, forced convection
Emission sound pressure level (EN ISO 2151)	47 dB(A)
Weight	23 kg 50.71 lb
Gas ballast	Yes
Operating altitude, max.	2500 m

Order number	
HiScroll 18	PD S30 010

Accessories	
Adapters (electrical) RS-232/485	
Y-distributor M12 to RS-485	P 4723 010
USB RS-485 converter	PM 061 207 -T
Cables Connection cables	
Adapter RS485 M12	PE 100 150 -X
Cables Mains cables / Power cords	
Mains cable 230 V AC, CEE 7/7 to C13, 3 m	P 4564 309 ZA
Mains cable 115 V AC, NEMA 5-15 to C13, 3 m	P 4564 309 ZL
Cables RS-485 Interface cables	
Interface cable, M12 m straight/M12 m straight, 3 m	PM 061 283 -T
Caps/Clamps Screw-on Caps	
Screw cap for gas ballast valve	PD 100 067
Control Devices Power supplies and control displays	
HPU 001, Handheld Programming Unit	PM 051 510 -T
DCU 002, Display Control Unit	PM 061 348 AT
Flanges/Ports Blank flanges	
Push-in fitting G 1/8" including seal for hose connection (8/6 mm)	P 4131 029 G
Protection Dust separators/Inlet particle filters	
SAS 25 S, DN 25 ISO-KF, polyester filter	PK Z60 507

VACUUM SOLUTIONS FROM A SINGLE SOURCE

Pfeiffer Vacuum stands for innovative and custom vacuum solutions worldwide, technological perfection, competent advice and reliable service.

COMPLETE RANGE OF PRODUCTS

From a single component to complex systems:

We are the only supplier of vacuum technology that provides a complete product portfolio.

COMPETENCE IN THEORY AND PRACTICE

Benefit from our know-how and our portfolio of training opportunities!

We support you with your plant layout and provide first-class on-site service worldwide.

Are you looking for a
perfect vacuum solution?
Please contact us:

Pfeiffer Vacuum GmbH
Headquarters · Germany
T +49 6441 802-0
info@pfeiffer-vacuum.de

www.pfeiffer-vacuum.com

All data subject to change without prior notice.

PFEIFFER  **VACUUM**