

OPERATING INSTRUCTIONS

EN

Translation of the original instructions

IMR 265

Compact Process Ion Gauge

PFEIFFER  **VACUUM**

Product Identification

In all communications with Pfeiffer Vacuum, please specify the information on the product nameplate. For convenient reference copy that information into the space provided below.

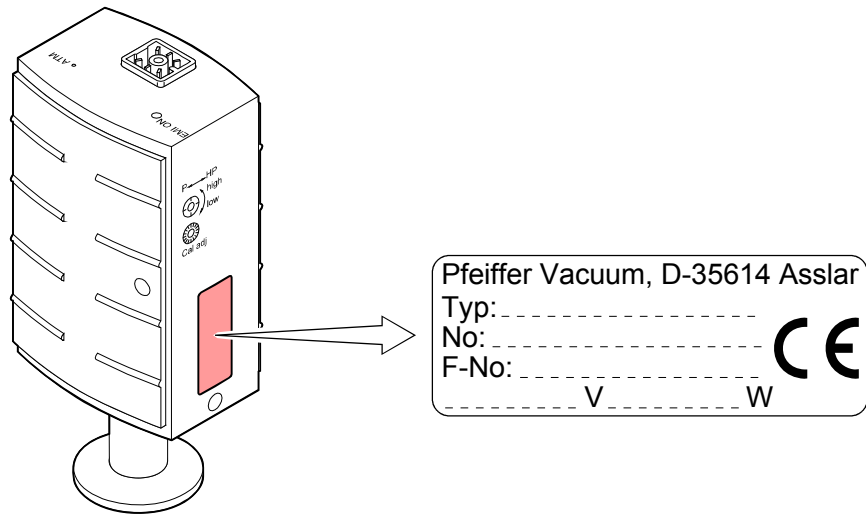

Validity

This document applies to products with part number

- PT R26 500 (flange DN 25 ISO-KF)
- PT R26 501 (flange DN 40 ISO-KF)
- PT R26 502 (flange DN 16 CF-F)
- PT R26 503 (flange DN 40 CF-F)
- PT R26 504 (flange DN 16 ISO-KF)
- PT R26 505 (with 3/4" tube)

The part number (No) can be taken from the product nameplate.

We reserve the right to make technical changes without prior notice.

Intended Use

The IMR 265 Compact Process Ion Gauge has been designed for vacuum measurement of non-flammable gases and gas mixtures in a pressure range $2 \times 10^{-6} \dots 1000$ hPa, measurement in the range of $\approx 1 \dots 1000$ hPa serving as trend indication (control range).

It must not be used for measuring flammable or combustible gases in mixtures containing oxidants (e.g. atmospheric oxygen) within the explosion range.

The gauge is a part of the Pfeiffer Vacuum Compact Gauge family and can be operated in connection with a Pfeiffer Vacuum measurement and control unit for Compact Gauges or with another control device.



Functional Principle

Over the whole measuring range, the measuring signal is output as logarithm of the pressure.

The IMR 265 functions with a HP high pressure hot cathode ionization manometer, which is controlled by the built-in Pirani manometer (control range). The hot cathode is switched on only below the switching threshold of 5×10^{-2} hPa (to prevent filament burn-out). For pressures above this threshold, the Pirani signal is output.

Contents

Product Identification	2
Validity	2
Intended Use	2
Functional Principle	2
1 Safety	4
1.1 Symbols Used	4
1.2 Personnel Qualifications	4
1.3 General Safety Instructions	4
1.4 Liability and Warranty	4
2 Technical Data	5
3 Installation	9
3.1 Vacuum Connection	9
3.1.1 Removing and Installing the Electronics Unit	11
3.2 Power Connection	12
3.2.1 Use With a Measurement and Control Unit for Compact Gauges	12
3.2.2 Use With Other Control Devices	12
4 Operation	14
4.1 Measuring Principle, Measuring Behavior	14
4.2 Operational Principle of the Gauge	17
5 Maintenance	18
5.1 Maintenance	18
5.2 Adjusting the Gauge	18
5.3 Adjusting the Calibration Setting of the Hot Cathode System	19
5.4 Cleaning the Gauge	19
5.5 Replacing the Baffle	20
5.6 Replacing the Sensor	21
5.7 What to Do in Case of Problems	21
6 Deinstallation	22
7 Returning the Product	23
8 Options	23
9 Spare Parts	24
10 Disposal	24
Appendix	25
A: Conversion Table for Pressure Units	25
B: Relationship Output Signal – Pressure	25
C: Gas Type Dependence	26

For cross-references within this document, the symbol (→  XY) is used, for cross-references to other documents, the symbol (→  [Z]).

1 Safety

1.1 Symbols Used



DANGER

Information on preventing any kind of physical injury.



WARNING

Information on preventing extensive equipment and environmental damage.



Caution

Information on correct handling or use. Disregard can lead to malfunctions or minor equipment damage.

1.2 Personnel Qualifications



Skilled personnel

All work described in this document may only be carried out by persons who have suitable technical training and the necessary experience or who have been instructed by the end-user of the product.

1.3 General Safety Instructions

- Adhere to the applicable regulations and take the necessary precautions for the process media used.
Consider possible reactions between the materials (→ 6) and the process media.
Consider possible reactions (e.g. explosion) of the process media due to heat generated by the product.
- Adhere to the applicable regulations and take the necessary precautions for all work you are going to do and consider the safety instructions in this document.
- Before beginning to work, find out whether any vacuum components are contaminated. Adhere to the relevant regulations and take the necessary precautions when handling contaminated parts.

Communicate the safety instructions to all other users.

1.4 Liability and Warranty

Pfeiffer Vacuum assumes no liability and the warranty becomes null and void if the end-user or third parties

- disregard the information in this document
- use the product in a non-conforming manner
- make any kind of changes (modifications, alterations etc.) to the product
- use the product with accessories not listed in the corresponding product documentation.

The end-user assumes the responsibility in conjunction with the process media used.

Gauge failures due to contamination or wear and tear, as well as expendable parts (filament), are not covered by the warranty.

2 Technical Data

Measurement	Measuring range (air, N ₂)	
	Hot cathode	$2 \times 10^{-6} \dots 1 \text{ hPa}$
	Pirani (control range)	$1 \times 10^{-2} \dots 1000 \text{ hPa}$
	Repeatability	(after 10 min. stabilization)
	$10^{-5} \dots 10^{-1} \text{ hPa}$	≈ 2% measurement
	$10^{-1} \dots 100 \text{ hPa}$	≈ 30% measurement
	Gas type dependence	→ Appendix C
Emission	Switching threshold (selectable from 5 defined setpoints)	1 hPa $5 \times 10^{-1} \text{ hPa}$ $2 \times 10^{-1} \text{ hPa}$ $1 \times 10^{-1} \text{ hPa}$ $5 \times 10^{-2} \text{ hPa}$ (default)
	Emission current continually rising	
	From 1 hPa	4 μA
	To $2 \times 10^{-6} \text{ hPa}$	130 μA
	Anode voltage	180 V
Output signal	Voltage rating	0 ... 10.2 V
	Measuring range	
	Hot cathode	1.5 ... 7.5 V
	Pirani	8.5 ... 9.75 V
	Ovrange hot cathode	$7.5 \text{ V} < U < 8.0 \text{ V}$
	Underrange hot cathode	$0.5 \text{ V} < U < 1.5 \text{ V}$
	Ovrange Pirani	$9.75 \text{ V} < U < 10.2 \text{ V}$
	Underrange Pirani	$8.0 \text{ V} < U < 8.5 \text{ V}$
	Relationship voltage-pressure	→ Appendix B logarithmic
	Hot cathode	1.00 V / decade
	Pirani	0.25 V / decade
	Error signals	→ 21
	0.3 V	• hot cathode error
0.5 V	• Pirani error	
	• electronics unit not correctly mounted to sensor	
	Minimum load	10 kΩ, short circuit proof
Identification of the gauge	Resistor (Pin 1, U _{max} = 4.25 V)	15.2 kΩ referenced to supply common
Adjustment	Pirani	
	HV	automatic by hot cathode circuit in range $1 \dots 3 \times 10^{-3} \text{ hPa}$
	ATM (<ATM> button)	via <ATM> button (keep button de-pressed for at least 5 seconds) at at-mospheric pressure
	Hot cathode	calibration setting with 16 position switch according to label
Supply		

DANGER

The gauge may only be connected to power supplies, instruments or control devices that conform to the requirements of a grounded protective extra-low voltage (PELV). The connection to the gauge has to be fused ¹⁾.

Voltage at gauge	20 ... 30 VDC ²⁾ max. ripple 1 V _{pp}
Power consumption	
Standard	≤0.5 A
Emissions start (<200 ms)	≤1.4 A
Power consumption	≤16 W
Fuse necessary ¹⁾	≤1.25 AT
Voltage at the power supply for maximum cable length	21 ... 30 V max. ripple 1 V _{pp}

Sensor cable

Electrical connection	Hirschmann compact connector type GO 6, 6 poles, male
Tightening torque	≤0.2 Nm
Cable	5 poles plus screening
Cable length max.	35 m (0.25 mm ² conductor) 50 m (0.34 mm ² conductor) 100 m (1.0 mm ² conductor)

Grounding concept

Vacuum flange-supply common	direct electrical connection
Signal common-supply common	conducted separately; only differential measurement possible due to high power consumption

Vacuum

Materials on the vacuum side	
Housing, anode holder, screens	stainless steel
Feedthrough	NiFe nickel plated
Isolator	glass
Cathode	iridium, yttrium oxide
Cathode holder	molybdenum, platinum
Pirani element	tungsten, copper, glass
Internal volume	
DN 25 ISO-KF	≤24 cm ³
DN 40 ISO-KF	≤24 cm ³
DN 40 CF-R	≤34 cm ³
Pressure max.	500 kPa (absolute), (only for inert gases and temperatures <100 °C)

¹⁾ Pfeiffer vacuum measurement and control units for Compact Gauges fulfill these requirements.

²⁾ The minimum voltage of the power supply must be increased proportionally to the length of the sensor cable.

Environment

Admissible temperatures

Storage	-20 ... 70 °C
Operation	0 ... 50 °C
Bakeout	+ 50 °C (with electronics unit) + 80 °C (at the flange, with electronics unit) +150 °C (without electronics unit)

Relative humidity

Year's mean	≤65% (no condensation)
During 60 days	≤85% (no condensation)

Use

indoors only
altitude up to 2000 m NN

Degree of protection

IP 30

Dimensions [mm]

DN 16 ISO-KF flange and 3/4" tube

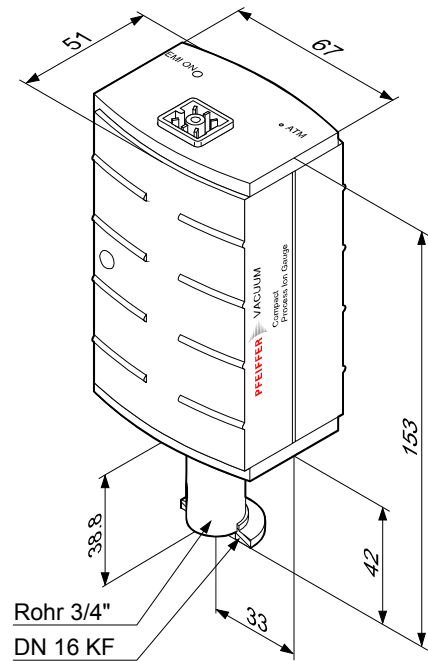

Weight

≈285 g

DN 25 ISO-KF and DN 40 ISO-KF flange

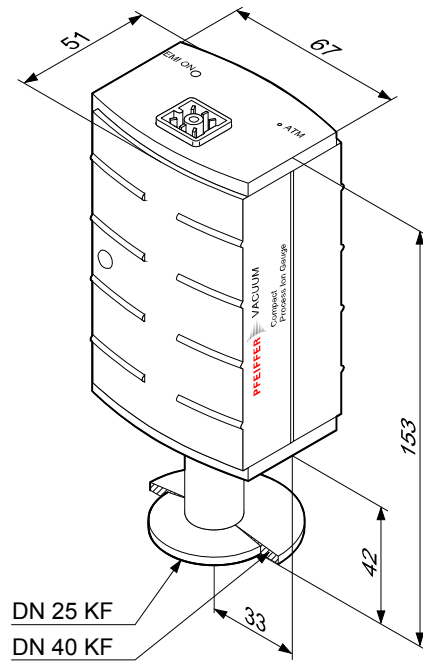

DN 25 KF
DN 40 KF

Weight ≈ 315 g

DN 16 CF-F and DN 40 CF-F flange

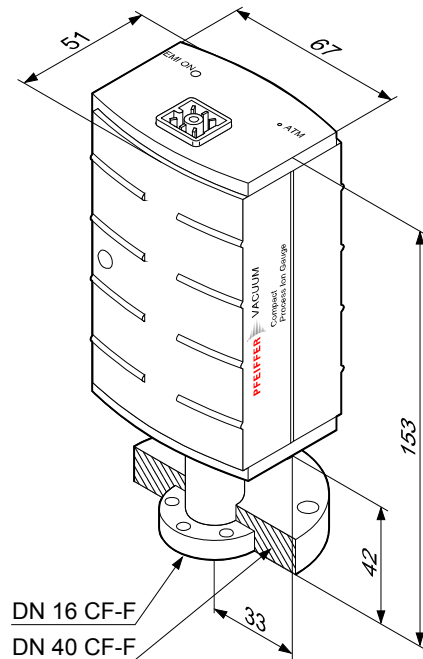

DN 16 CF-F
DN 40 CF-F

Weight $\approx 300 \dots 550$ g

3 Installation

3.1 Vacuum Connection



DANGER

DANGER: overpressure in the vacuum system >100 kPa
Injury caused by released parts and harm caused by escaping process gases can result if clamps are opened while the vacuum system is pressurized.

Do not open any clamps while the vacuum system is pressurized. Use the type clamps which are suited to overpressure.



DANGER

DANGER: hazardous voltages
Incorrectly grounded products can be extremely hazardous in the event of a fault.

The gauge must be galvanically connected to the grounded vacuum chamber. This connection must conform to the requirements of a protective connection according to EN 61010:



- CF flanges fulfill this requirement.
- For gauges with a KF flange, use a conductive metallic clamping ring.
- For the 3/4" tube, take appropriate measures to fulfill this requirement.



Caution



Caution: vacuum component
Dirt and damages impair the function of the vacuum component.
When handling vacuum components, take appropriate measures to ensure cleanliness and prevent damages.

- The gauge should be mounted so that no vibrations occur.
- The gauge may be mounted in any direction. However, no particles and condensates should penetrate into the measuring chamber.
- See dimensional drawings (→  7) for space requirements.
- If the flange connection can only be made without the electronics unit, remove the electronics unit (→  11).
- The sensor can be baked out at up to 150 °C. For temperatures above 50 °C the electronics unit must be removed (→  11).

Procedure

- 1 Remove the protective cap.



Notice:
Store the protective cap and reinstall it when deinstalling the gauge.

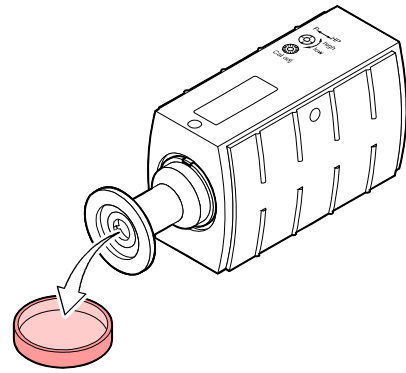

- 2 Establish the flange connection.

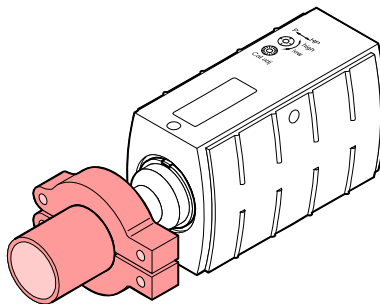
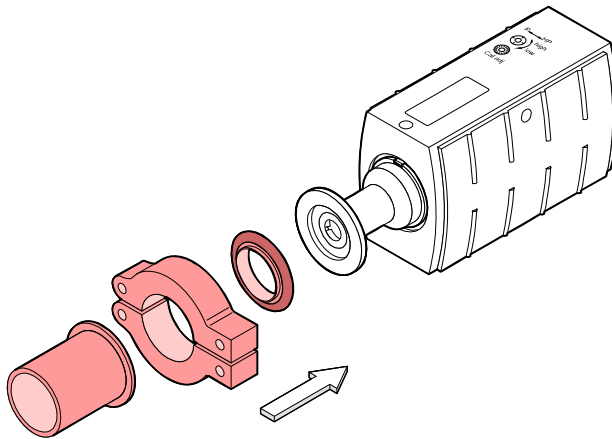

Install the gauge in such a way that there is sufficient clearance for adjustment (→ 16, 18, 19).

3.1.1 Removing and Installing the Electronics Unit

Tools / material required

- Allen wrench AF 2.5

Removal

- a) Carefully unfasten the hexagon socket set screw (1) on the side of the electronics unit (2). Make sure not to lose the hexagon socket set screw.

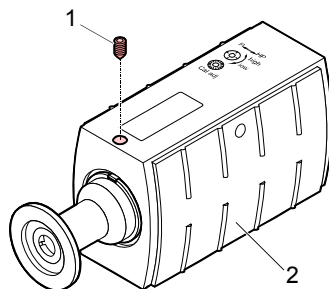

- b) Remove the electronics unit **without twisting it**.

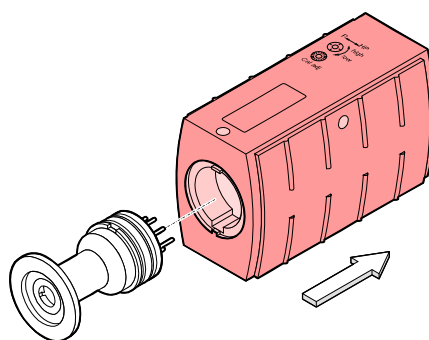

Mounting

- a) Place the electronics unit on the sensor (3) (be careful to correctly position the pins and the guide notch (4)).

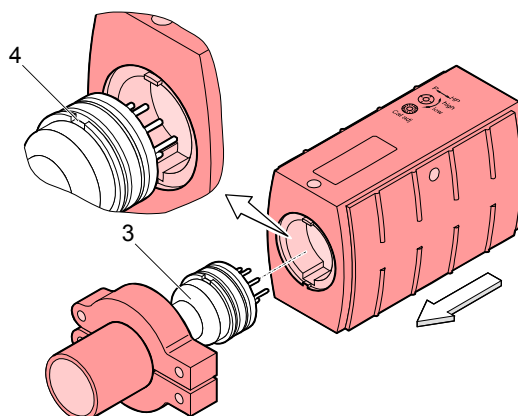

- b) Slide the electronics unit up to the mechanical stop and lock it with the hexagon socket set screw (1).

3.2 Power Connection

3.2.1 Use With a Measurement and Control Unit for Compact Gauges

If the gauge is used with a Pfeiffer Vacuum measurement and control unit for Compact Gauges, a corresponding sensor cable is required (→ 23).

- Plug in the connector on the gauge and secure it with the screw (tightening torque ≤ 0.2 Nm).
- Connect the other end of the cable to the measurement and control unit and secure it.

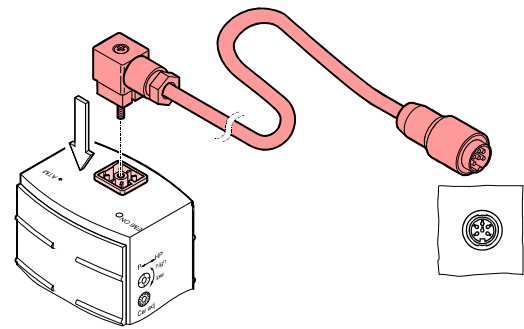

3.2.2 Use With Other Control Devices

The gauge can also be used with other control devices. In such a case, an individual sensor cable can be made (connector → 23).

Due to the high power consumption, only differential measurement between the signal output (pin 2) and the signal common (pin 3) is possible.

Procedure

- 1 Open the connector (ordering number → 23).

- 2 Prepare the cable.

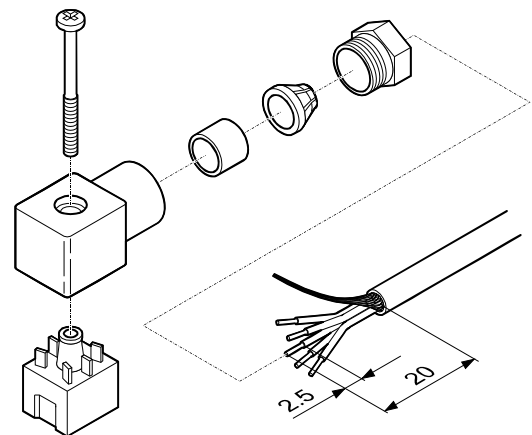

- 3 Solder the sensor cable according to the diagram.

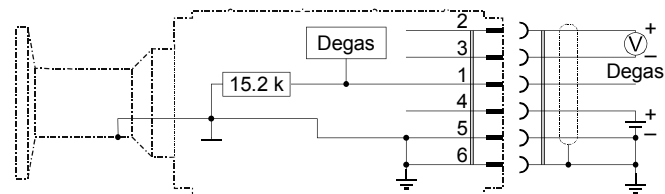

Power connection

- Pin 1 identification ($U \leq 4.25$ V)
- Pin 2 signal output (measuring signal)
- Pin 3 signal common GND
- Pin 4 supply
- Pin 5 supply common GND
- Pin 6 screening

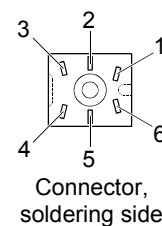

**WARNING**

The supply common (pin 5) and the screen (pin 6) must be connected at the power supply with protective ground. Incorrect connection, incorrect polarity or inadmissible supply voltages can damage the gauge.

- 4 Reassemble the connector.
- 5 Equip the other end of the cable with a connector which matches the control device.
- 6 Plug in the connector.
Secure the connector on the gauge with the screw (tightening torque ≤ 0.2 Nm).

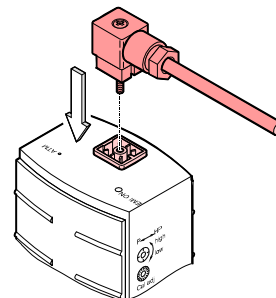

- 7 Connect the other end of the cable to the control device.

4 Operation

When the supply voltage is fed, the measuring signal is available between pins 2 and 3. Over the whole measuring range, the measuring signal is output as logarithm of the pressure (relationship between output signal and pressure → Appendix B).

Allow for a stabilizing time of approx. 10 min. Once the gauge has been switched on, permanently leave it on irrespective of the pressure.

4.1 Measuring Principle, Measuring Behavior

High pressure (HP) hot cathode

The IMR 265 consists of two separate measuring systems (high pressure (HP) hot cathode and Pirani).

The HP hot cathode measuring system is based on the electrode arrangement shown in Figure 1, which grants sensitivity, linearity, and stability even at high pressures.

The measuring principle of this system is based on gas ionization. Electrons emitted by the hot cathode (F) ionize a number of molecules proportional to the pressure in the measuring chamber. The ion collector (IC) collects the thus generated ion current I_+ and feeds it to the electrometer amplifier of the measuring instrument. The ion current is dependent on the emission current I_e , the gas type, and the gas pressure p according to the following relationship:

$$I_+ = I_e \times p \times C$$

Factor C represents the sensitivity of the gauge. It is generally specified for N_2 .

The lower measurement limit is 2×10^{-6} hPa.

In order for the entire range of 2×10^{-6} hPa ... 1 hPa to be covered, the emission current is continually increased from 4 μA at 1 hPa to 130 μA at 2×10^{-6} hPa (no transients due to switching of the emission current).

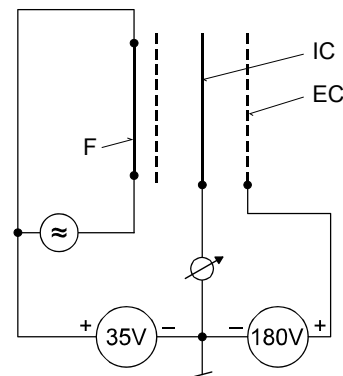
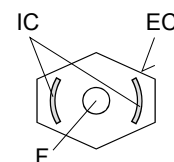

Figure 1

Diagram of the HP measuring system

- F hot cathode (filament)
- IC ion collector
- EC electron collector (anode grid)



Pirani (control range)

Within certain limits, the thermal conductance of gases is pressure dependent. This physical phenomenon is used for pressure measurement in the thermal conductance vacuum meter according to Pirani. A self-adjusting bridge is used as measuring circuit. A thin tungsten wire is used as sensor element. Wire resistance and thus temperature are kept constant through a suitable control circuit. The electric power supplied to the wire is a measure for the thermal conductance and thus the gas pressure. The basic principle of the self adjusting bridge circuit is shown in Figure 2.

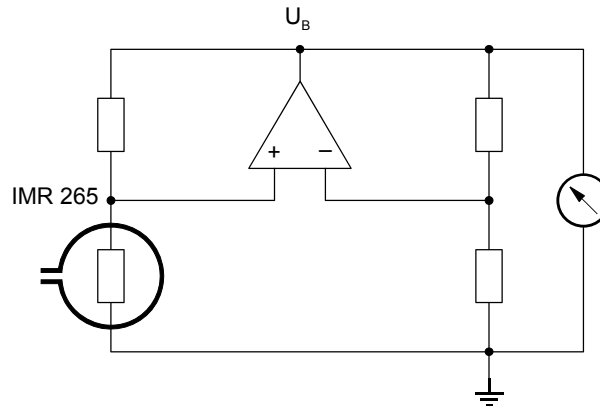
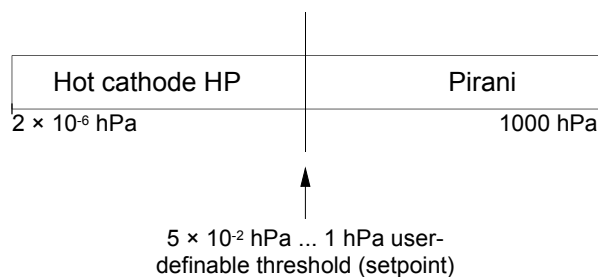

Figure 2

The bridge voltage U_B is a measure for the gas pressure and is further processed electronically (linearization, digitizing).

Measuring range Switching threshold

The IMR 265 covers the measuring range $2 \times 10^{-6} \dots 1000$ hPa.



- The Pirani permanently monitors the pressure.
- The hot cathode (controlled by the Pirani) is activated only at pressures $< 1 \dots 5 \times 10^{-2}$ hPa (threshold can be set with a switch).

If the measured pressure is higher than the setpoint (which can be selected with a switch within the range of $1 \dots 5 \times 10^{-2}$ hPa), the hot cathode remains off and the Pirani value is output as signal (\rightarrow Appendix B).

When the pressure measured by the Pirani drops below the threshold, the hot cathode is activated. This is indicated by a green lamp. After warming up of the measuring system, the hot cathode value is output. When the pressure rises above the set threshold, the hot cathode is deactivated, and the Pirani value is output again.

Selecting the setpoint

The IMR 265 has five definable switching thresholds. It is thus possible to prevent the switching range from being situated within the process pressure range. The factory setting of the threshold is 5×10^{-2} hPa. Another setpoint can be selected via the <P ↔ HP> switch. Since the contamination of the hot cathode system is reduced at low pressures, the lowest possible setpoint should be selected.

Caution



Since the switch position is only polled upon activation of the gauge, the setpoint should be selected before the gauge is turned on.

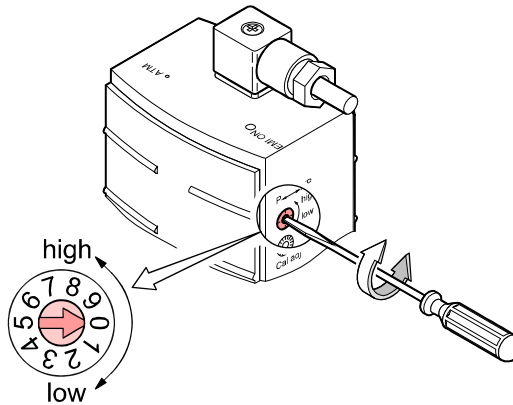

Switch position	Corresponding setpoint
0; 1	1 hPa
2; 3	5×10^{-1} hPa
4; 5	2×10^{-1} hPa
6; 7	1×10^{-1} hPa
8; 9	5×10^{-2} hPa (default)

Accuracy

The gauge is factory-calibrated. Adjustment may become necessary due to use in different climatic conditions, extreme temperatures, contamination or aging (→ 18).

The accuracy is reduced in the pressure range above 1×10^{-1} hPa and below 1×10^{-5} hPa.

Gas type dependence

The output signal is gas type dependent. The characteristic curves (→ Appendix B) are accurate for dry air, N_2 and O_2 . They can be mathematically converted for other gases (→ Appendix C).

If you are using a Pfeiffer Vacuum measurement and control unit for Compact Gauges, you can enter a calibration factor to correct the displayed measured value (→ of the corresponding measurement unit).

Contamination



Gauge failures due to contamination or wear and tear, as well as expendable parts (filament), are not covered by the warranty.

The IMR 265 is designed in such a way that contamination by process products is minimal. The baffle and the closed internal design of the measuring system as well as the heat generated by the measuring system contribute to this.

The IMR 265 is factory-adjusted in such a way that the hot cathode is switched on at $\approx 5 \times 10^{-2}$ hPa. The gauge can also be switched externally by the supply voltage, control by the Pirani still being insured.

In case of severe contamination, the measuring system should be replaced (→  21).

4.2 Operational Principle of the Gauge

The measuring currents of the HP hot cathode/Pirani sensors are converted into a pressure dependent frequency by a current/frequency-converter. A microcontroller converts this frequency signal into a digital value of the measured pressure. This value is output as analog measuring signal of 0 ... 10.2 V at (pin 2 / pin 3), the valid pressure range being 1.5 ... 7.5 V (HP hot cathode) and 8.5 ... 9.75 V (Pirani).

In addition to converting the measuring signal, the microcontroller's functions include monitoring of the emission and calculation of the total pressure based on the measurements of the two sensors.

5 Maintenance

5.1 Maintenance



DANGER

DANGER: contaminated parts

Contaminated parts can be detrimental to health and environment.

Before beginning to work, find out whether any parts are contaminated. Adhere to the relevant regulations and take the necessary precautions when handling contaminated parts.

5.2 Adjusting the Gauge

The gauge is factory-calibrated. Through use in different climatic conditions, installation position, aging, contamination, exchange of the sensor (→ 21) a shifting of the characteristic curve can occur and readjustment may thus become necessary.

Adjustment is necessary when

- at atmospheric pressure, the output signal is 9.75 V (pressure indication <math><1000\text{ hPa}</math>)
- during venting, the output voltage of $9.75\text{ V}^{1)}$ (pressure indication 1000 hPa) is reached before the pressure reading corresponds to atmosphere

¹⁾ The output voltage is limited to 10.2 V by the software.

The following steps have to be performed:

- HV adjustment Pirani
- ATM adjustment Pirani

HV adjustment Pirani

When the gauge is activated, the Pirani measuring circuit is automatically adjusted by the hot cathode circuit (when the pressure reaches the range $p = 1 \dots 3 \times 10^{-3}\text{ hPa}$ for the first time).

ATM adjustment Pirani

Required tools

- Pin approx. $\varnothing 1.3 \times 50\text{ mm}$ (e.g. a bent open paper clip)

Procedure

- 1 Operate the gauge at atmospheric pressure for approx. 10 minutes. If the gauge was operated before in the hot cathode range, a cooling-down time of approx. 30 minutes is to be expected (gauge temperature = ambient temperature)..
- 2 Insert the pin through the opening marked $\langle\text{ATM}\rangle$ and push the button inside for at least 5 s.

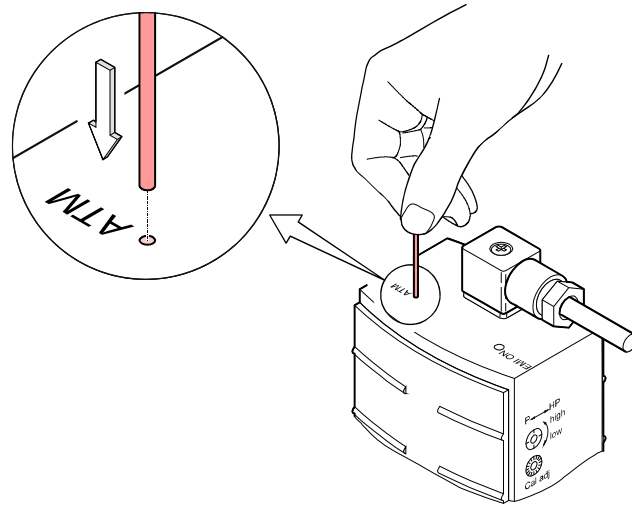

5.3 Adjusting the Calibration Setting of the Hot Cathode System

The sensor is factory calibrated. The calibration setting of the hot cathode range 0 ... F is printed on the label. Correct this value with the <Cal adj> switch to adjust the electronics to the sensor. Before operating the gauge for the first time or after replacing the sensor, check the calibration setting and adjust it if necessary.

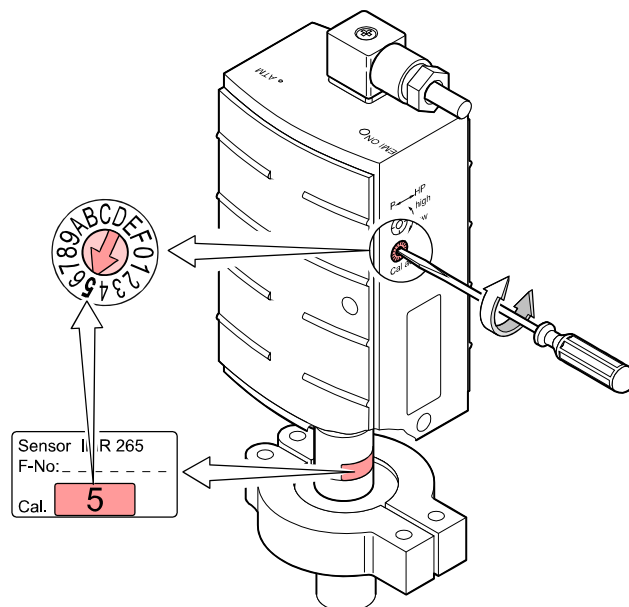

5.4 Cleaning the Gauge

The sensor (except for the baffle) cannot be cleaned. In case of severe contamination, it has to be replaced (→ 21). It can be assumed that the sensor is severely contaminated if the measured values are no longer stable. Symptoms of contamination are visible dirt and change of color.

A slightly damp cloth normally suffices for cleaning the outside of the gauge. Do not use any aggressive or scouring cleaning agents.

Caution



Make sure that no liquids get inside the product. Allow the gauge to dry thoroughly before putting it into operation again.

5.5 Replacing the Baffle

The baffle can be replaced in case of severe contamination .



Caution



Caution: dirt sensitive area

Touching the product or parts thereof with bare hands increases the desorption rate.

Always wear clean, lint-free gloves and use clean tools when working in this area.

Tools / materials required

- New baffle (→ 23)
- Screw driver No. 1
- Stick (e.g. pencil)

Procedure

- a) Carefully remove the baffle with the screw driver.

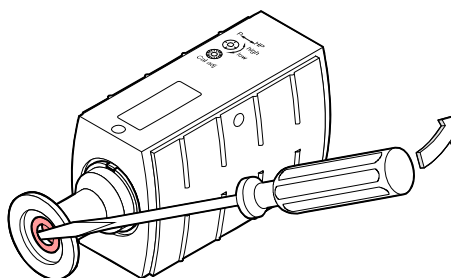

- b) Carefully place the new baffle on the sensor opening.

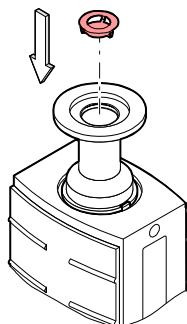

- c) Using a stick, carefully press the baffle down in the middle until it catches.

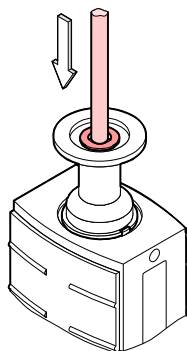

5.6 Replacing the Sensor

Replacement is necessary, when

- the sensor is severely contaminated
- the sensor is defective, e.g. filament broken.



Gauge failures due to contamination or wear and tear, as well as expendable parts (filament), are not covered by the warranty.

Tools / materials required

- Allen wrench AF 2.5
- Spare sensor (→ 24)

Procedure

- Deinstall the gauge (→ 22).
- Remove the electronics unit from the faulty sensor and mount it on the new sensor (→ 11).
- Install the gauge (→ 9).
- Adjust the calibration setting of the hot cathode system (→ 19).
- Put the gauge into operation.
- Adjust the gauge (→ 18).

5.7 What to Do in Case of Problems

Problem	Possible cause	Correction
No measuring signal	No supply voltage	Turn on the power supply
	Sensor cable defective or not correctly plugged in	Check sensor cable
	Gauge in undefined condition	Turn gauge off and on again (reset)
Measuring signal 0.3 V	Hot cathode error (sensor faulty)	Replace sensor (→ 21)
Measuring signal 0.5 V	Pirani error (sensor faulty)	Replace sensor (→ 21)
	Electronics unit not correctly mounted on sensor	Check connection



In case of an error, it may be helpful to first turn the supply voltage off and on again after 5 s.

6 Deinstallation

STOP DANGER



DANGER: contaminated parts

Contaminated parts can be detrimental to health and environment. Before beginning to work, find out whether any parts are contaminated. Adhere to the relevant regulations and take the necessary precautions when handling contaminated parts.



Caution



Caution: vacuum component

Dirt and damages impair the function of the vacuum component. When handling vacuum components, take appropriate measures to ensure cleanliness and prevent damages.

Procedure

- 1 Vent the vacuum system.
- 2 Take gauge out of operation.
- 3 Unplug connection cable.

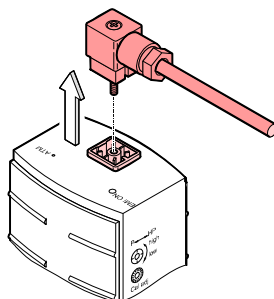

- 4 Remove gauge from the vacuum system.

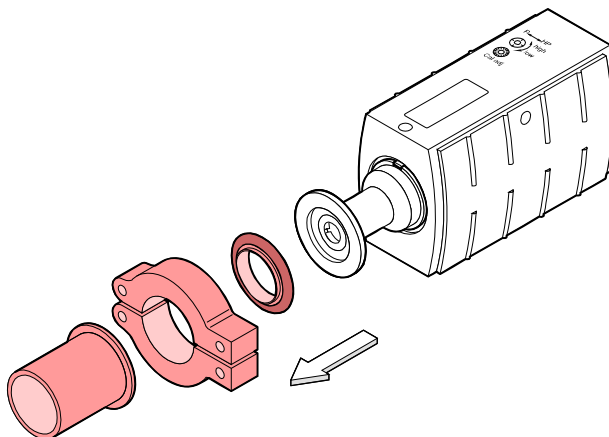

- 5 Place the protective cap.

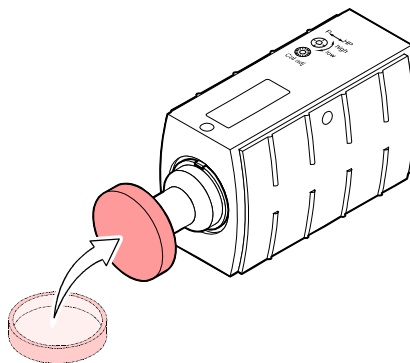

7 Returning the Product

 **WARNING**

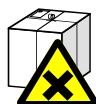

WARNING: forwarding contaminated products

Contaminated products (e.g. radioactive, toxic, caustic or micro-biological hazard) can be detrimental to health and environment.

Products returned to Pfeiffer Vacuum should preferably be free of harmful substances. Adhere to the forwarding regulations of all involved countries and forwarding companies and enclose a duly completed declaration of contamination^{*)}.

^{*)} Form under www.pfeiffer-vacuum.com

Products that are not clearly declared as "free of harmful substances" are decontaminated at the expense of the customer.

Products not accompanied by a duly completed declaration of contamination are returned to the sender at his own expense.

8 Options

	Ordering number
Sensor cable for connection to Pfeiffer Vacuum measurement and control unit for Compact Gauges	
3 m	PT 448 250-T
6 m	PT 448 251-T
10 m	PT 448 252-T
Hirschmann connection socket	
GO 6 WF, 6 poles, angled, female	B 4707 283 MA
Baffle	PT 120 125-T

9 Spare Parts

When ordering spare parts, always indicate:

- all information on the product nameplate
- description and ordering number according to the spare parts list

	Ordering number
Sensor IMR 265, DN 25 ISO-KF flange (Allen wrench included)	PT 120 111-T
Sensor IMR 265, DN 40 ISO-KF flange (Allen wrench included)	PT 120 112-T
Sensor IMR 265, DN 16 CF-F flange (Allen wrench included)	PT 120 113-T
Sensor IMR 265, DN 40 CF-F flange (Allen wrench included)	PT 120 114-T
Sensor IMR 265, DN 16 ISO-KF flange (Allen wrench included)	PT 120 115-T
Sensor IMR 265, 3/4" tube (Allen wrench included)	PT 120 116-T
Electronics unit IMR 265 (Allen wrench included)	PT 120 110-T

10 Disposal

DANGER

DANGER: contaminated parts
Contaminated parts can be detrimental to health and environment. Before beginning to work, find out whether any parts are contaminated. Adhere to the relevant regulations and take the necessary precautions when handling contaminated parts.

WARNING

WARNING: substances detrimental to the environment
Products or parts thereof (mechanical and electric components, operating fluids etc.) can be detrimental to the environment. Dispose of such substances in accordance with the relevant local regulations.

Separating the components

After disassembling the product, separate its components according to the following criteria:

Contaminated components

Contaminated components (radioactive, toxic, caustic, or biological hazard etc.) must be decontaminated in accordance with the relevant national regulations, separated according to their materials, and disposed of.

Other components

Such components must be separated according to their materials and recycled.

Appendix

A: Conversion Table for Pressure Units

	mbar	bar	Pa	hPa	kPa	Torr mm HG
mbar	1	1×10 ⁻³	100	1	0.1	0.75
bar	1×10 ³	1	1×10 ⁵	1×10 ³	100	750
Pa	0.01	1×10 ⁻⁵	1	0.01	1×10 ⁻³	7.5×10 ⁻³
hPa	1	1×10 ⁻³	100	1	0.1	0.75
kPa	10	0.01	1×10 ³	10	1	7.5
Torr mm HG	1.332	1.332×10 ⁻³	133.32	1.3332	0.1332	1

1 Pa = 1 N/m²

B: Relationship Output Signal – Pressure

Conversion formulae

Output range
hot cathode:

$$p = 10^{U-c_1} \Leftrightarrow U = c_1 + \log_{10} p$$

Output range
Pirani:

$$p = 10^{4(U-c_2)} \Leftrightarrow U = c_2 + 0.25 \log_{10} p$$

U	p	c ₁	c ₂
[V]	[hPa]	7.5	9
[V]	[µbar]	4.5	8.25
[V]	[Torr]	7.625	9.031
[V]	[mTorr]	4.625	8.281

U	p	c ₁	c ₂
[V]	[micron]	4.625	8.281
[V]	[Pa]	5.5	8.5
[V]	[kPa]	8.5	9.25

where

- p Pressure
- U Output signal
- c₁, c₂ Constants (dependent on pressure unit)

valid in the ranges

- Hot cathode: 1.50 V ≤ U ≤ 7.50 V
- Pirani: 8.50 V ≤ U ≤ 9.75 V

Conversion curve

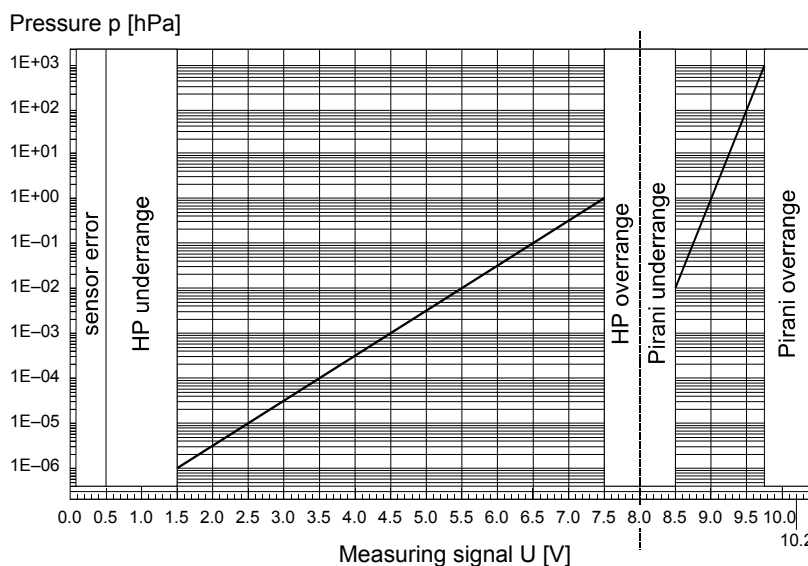

Conversion table

Output signal U [V]	Pressure p			
	[hPa]	[Torr]	[Pa]	
0 ... 0.5	sensor error			
0.5 ... 1.5	underrange			
1.5	HP Hot cathode ionization system	1.0×10^{-6}	7.5×10^{-7}	1.0×10^{-4}
2.5		1.0×10^{-5}	7.5×10^{-6}	1.0×10^{-3}
3.5		1.0×10^{-4}	7.5×10^{-5}	1.0×10^{-2}
4.5		1.0×10^{-3}	7.5×10^{-4}	1.0×10^{-1}
5.5		1.0×10^{-2}	7.5×10^{-3}	1
6.5		1.0×10^{-1}	7.5×10^{-2}	10
7.5		1	7.5×10^{-1}	100
7.5 ... 8.0	overrange			
8.0 ... 8.5	underrange			
8.5	Pirani system	1.0×10^{-2}	7.5×10^{-3}	1
8.75		1.0×10^{-1}	7.5×10^{-2}	10
9.0		1	7.5×10^{-1}	100
9.25		10	7.5	1000
9.5		100	75	10000
9.75		1000	750	100000
9.75 ... 10.2	overrange			

C: Gas Type Dependence

Below 10^{-1} hPa
HP hot cathode measuring
range

For gases other than air, the pressure can be determined by means of a simple conversion formula:

$$p_{\text{eff}} = C \times \text{indicated pressure}$$

where	Gas type	C
	Air (N ₂ , O ₂)	1.0
	Xe	0.4
	Kr	0.5
	Ar	0.8
	H ₂	2.4
	Ne	4.1
	He	5.9

These conversion factors are mean values.

Above 10^{-2} hPa
Pirani measuring range

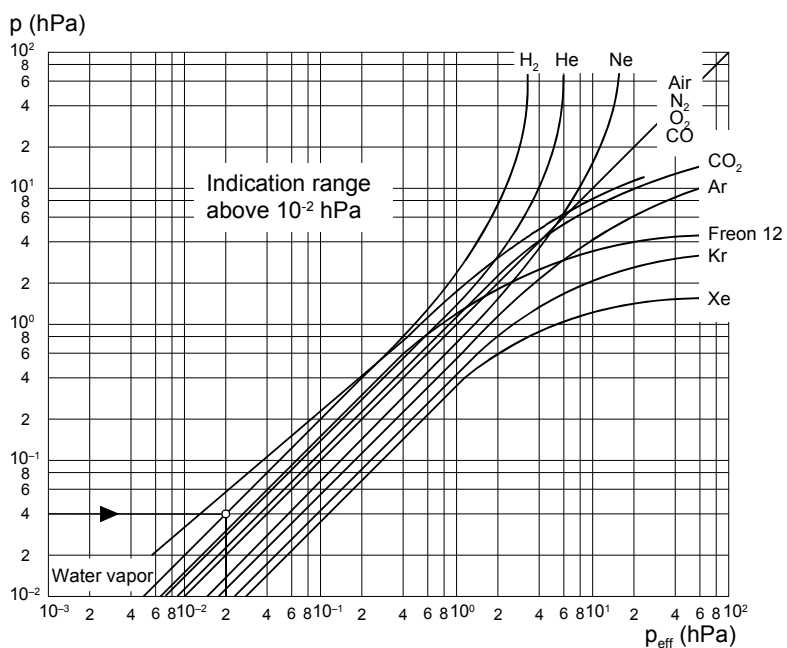

Caution



A mixture of gases and vapors is often involved. In this case, accurate determination is only possible with a partial-pressure measuring instrument.

VACUUM SOLUTIONS FROM A SINGLE SOURCE

Pfeiffer Vacuum stands for innovative and custom vacuum solutions worldwide, technological perfection, competent advice and reliable service.

COMPLETE RANGE OF PRODUCTS

From a single component to complex systems:
We are the only supplier of vacuum technology that provides a complete product portfolio.

COMPETENCE IN THEORY AND PRACTICE

Benefit from our know-how and our portfolio of training opportunities!
We can support you with your plant layout and provide first-class on-site-service worldwide.

Are you looking for a
perfect vacuum solution?
Please contact us:

Pfeiffer Vacuum GmbH
Headquarters • Germany
T +49 6441 802-0
info@pfeiffer-vacuum.de

www.pfeiffer-vacuum.com

PFEIFFER  **VACUUM**



bg5172ben/ b