

A PASSION FOR PERFECTION

for more info [CLICK HERE](#)
Ideal
vacuum products
www.idealvac.com

PFEIFFER  **VACUUM**



ASM 380

The ASM 380 is optimized for fast and accurate leak testing in all measurement ranges. It is the perfect combination of high dry pumping performance, sensitivity and mobility in the smallest footprint.



ASM 380, universal voltage

- High backing pump capacity (35 m³/h) and high helium pumping speed
- Fast time to test: unrivalled performances from small to large volumes
- Narrow design and highly maneuverable
- Customizable operator interface with 360° viewing
- Integrated SD card for data processing

Dimensions

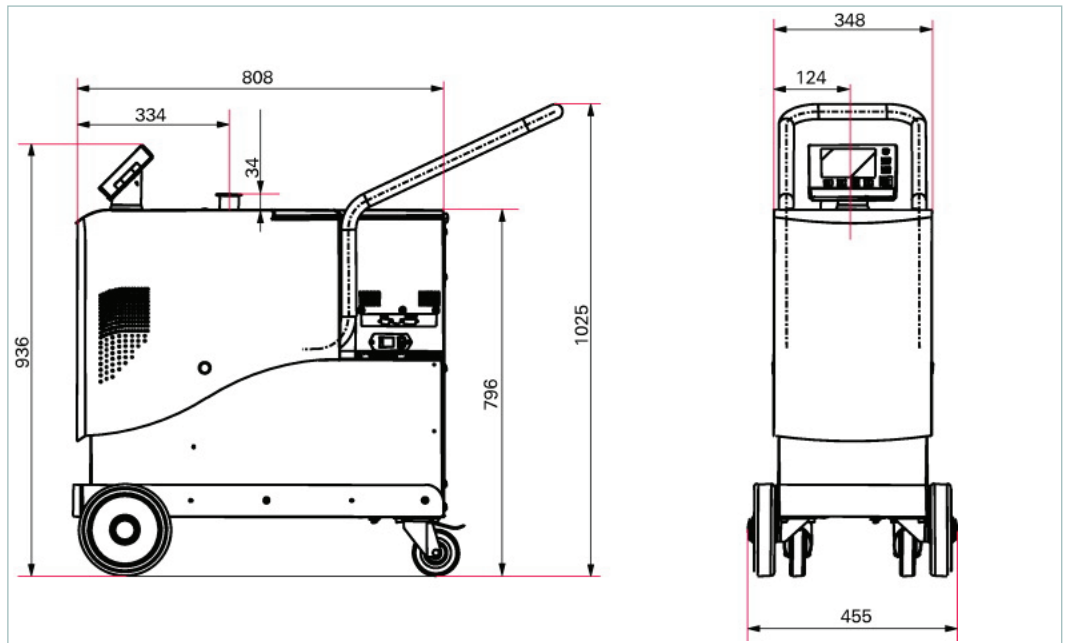

Technical Data	ASM 380, universal voltage
Backing pump	with oil free backing pump
Backing pump capacity	35 m ³ /h
Detectable gases	⁴ He, ³ He, H ₂
Dimensions (L x W x H)	1,065 x 455 x 1,025 mm 41.93 x 17.91 x 40.35 inch
Flange (in)	DN 40 ISO-KF
I/O interfaces	1 Digital input (Start cycle); 2 Digital outputs (Test mode ok, Helium signal above reject set point); 3 Analog outputs (Configurable: Helium signal log, Mantissa, Exponent, Inlet pressure)
Interface	RS-232
Maximum inlet test pressure	15 hPa 11.25 Torr 15 mbar
Minimum detectable leak rate for helium (sniffing leak detection)	1 · 10 ⁻⁸ Pa m ³ /s 7.5 · 10 ⁻⁸ Torr l/s 1 · 10 ⁻⁷ mbar l/s
Minimum detectable leak rate for helium (vacuum leak detection)	5 · 10 ⁻¹³ Pa m ³ /s 3.75 · 10 ⁻¹² Torr l/s 5 · 10 ⁻¹² mbar l/s
Noise level	53 dB (A)
Operating temperature	10-35 °C 50-95 °F 283-308 K
Power consumption	700 W
Pumping speed for He	7 l/s
Start-up time (20°C) with calibration	< 5.5 min
Start-up time (20°C) without calibration	< 4.5 min
Supply	90-240 V, 50/60 Hz
Test method	Vacuum and sniffing leak detection
Type	High Performance - Mobile
User interface	Graphic color touch screen (detachable)
Weight	110 kg 242.51 lb

Order number	
ASM 380	PSGB00E0MM9A

Accessories	
Bottle holder	
Bottle holder for ASM 380	118444
Standard remote control	
Remote control, leak rate in mbar l/s, legend in English	106688
Remote Control RC 500 WL for helium leak detector, wireless	PT 445 432-T

**Vacuum solutions
from a single source**

Pfeiffer Vacuum stands for innovative and custom vacuum solutions worldwide, technological perfection, competent advice and reliable service.

**Complete range
of products**

From a single component to complex systems:
We are the only supplier of vacuum technology
that provides a complete product portfolio.

**Competence in
theory and practice**

Benefit from our know-how and our portfolio of training
opportunities! We support you with your plant layout
and provide first-class on-site service worldwide.

**Are you looking for a
perfect vacuum solution?
Please contact us:**

Pfeiffer Vacuum GmbH
Headquarters · Germany
T +49 6441 802-0
info@pfeiffer-vacuum.de
www.pfeiffer-vacuum.com