

A PASSION FOR PERFECTION



PFEIFFER  VACUUM



## Data sheet · Hepta 100

Hepta 100, 220/380 V, 60 Hz

High-performance screw pump with a pumping speed of 130 m<sup>3</sup>/h

## Hepta 100, 220/380 V, 60 Hz

### Hepta 100



Similar Image

- High-performance screw pump with a pumping speed of 130 m<sup>3</sup>/h
- For mains voltage: 220/380, 60 Hz, 3 ph
- Ideal solution for all areas in which oil-free vacuum is required
- Lower energy costs thanks to internal compression
- For applications in the low and medium vacuum

### Characteristics

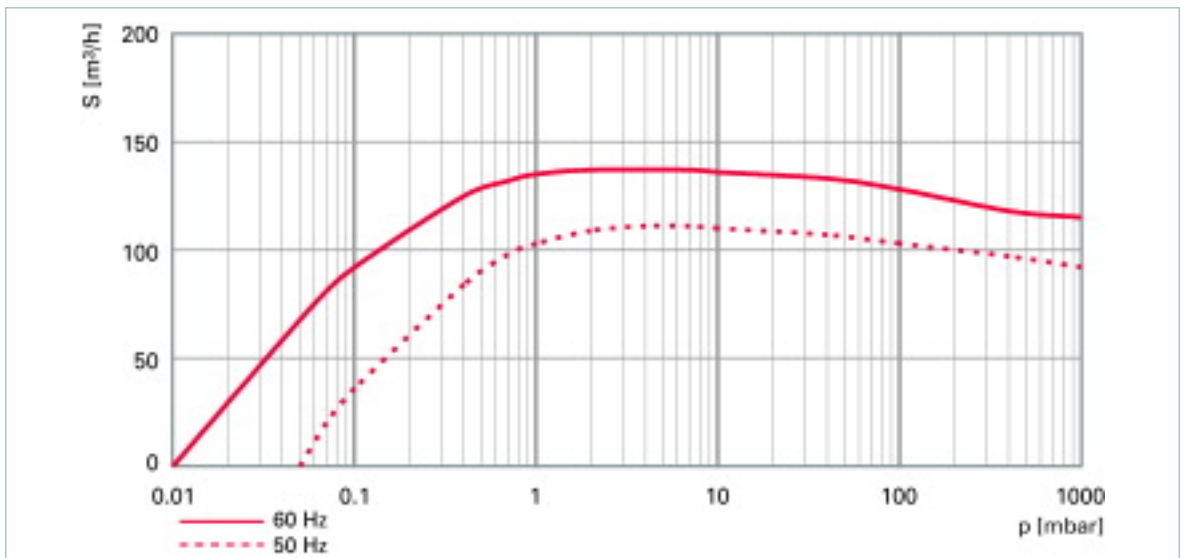

### Dimensions

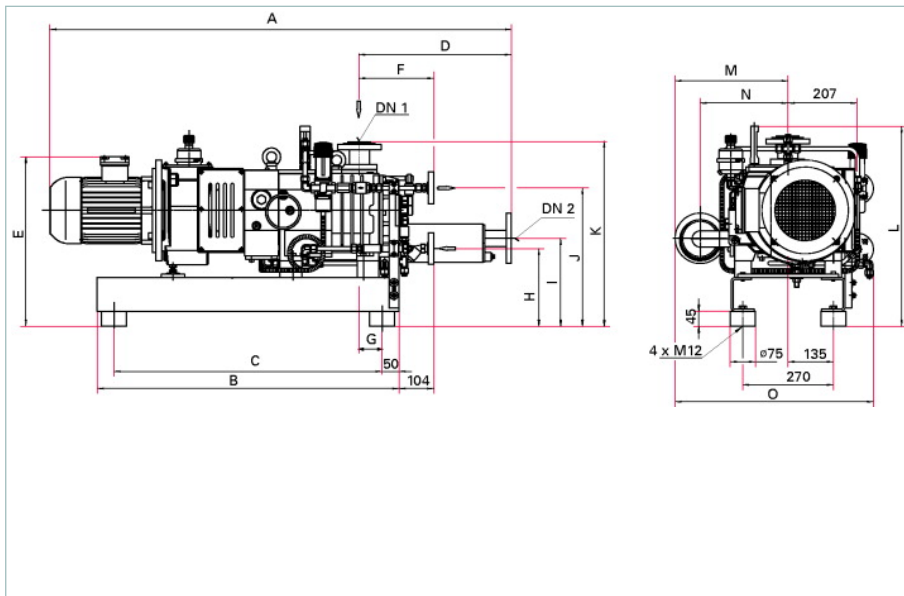

A	1395 mm
B	900 mm
C	800 mm
D	454 mm
DN 1	DN 63 ISO-K
DN 2	DN 40 PN 16
E	505 mm
F	222 mm
G	68 mm
H	232 mm
I	262 mm
J	412 mm
K	533 mm
L	597 mm
M	337 mm
N	262 mm
O	586 mm

## Hepta 100, 220/380 V, 60 Hz

Technical Data	Hepta 100, 220/380 V, 60 Hz
Ambient temperature	0-50 °C
Cooling water consumption	2-6 l/min
Cooling water pressure	300-600 kPa
Cooling water temperature	10-25 °C
Flange (in)	DN 63 ISO-F
Flange (out)	DN 40 PN 16
Mains requirement: voltage 60 Hz	220-380 V
Motor rating 60 Hz	4.8 kW
Nominal pumping speed at 60 Hz	130 m <sup>3</sup> /h
Nominal rotation speed at 60 Hz	3600 rpm
Operating fluid	D1
Operating fluid filling	1.6 l
Protection category	IP 55
Sound pressure level	74 dB (A)
Ultimate pressure	<= 0.01 hPa
Weight	275 kg
<b>Order number</b>	<b>PUV10123</b>
<b>Accessories HenaLine&amp;trade;</b>	
SAS 63, DN 63 ISO-K, polyester filter	<b>PKZ60511</b>
<b>Accessories UnoLine&amp;trade; Plus</b>	
Barretter actuation unit 3TF	<b>P4768051FQ</b>
<b>Consumables</b>	<b>Hepta 100, 220/380 V, 60 Hz</b>
D1, oil, 1 l	<b>PK005875-T</b>
D1, oil, 5 l	<b>PK005876-T</b>
D1, oil, 20 l	<b>PK005877-T</b>

**Vacuum solutions  
from a single source**

Pfeiffer Vacuum stands for innovative and custom vacuum solutions worldwide, technological perfection, competent advice and reliable service.

**Complete range  
of products**

From a single component to complex systems:  
We are the only supplier of vacuum technology  
that provides a complete product portfolio.

**Competence in  
theory and practice**

Benefit from our know-how and our portfolio of training  
opportunities! We support you with your plant layout  
and provide first-class on-site service worldwide.

**Are you looking for a  
perfect vacuum solution?  
Please contact us:**

**Pfeiffer Vacuum GmbH**  
Headquarters · Germany  
T +49 6441 802-0  
info@pfeiffer-vacuum.de  
[www.pfeiffer-vacuum.com](http://www.pfeiffer-vacuum.com)