



**Pressure &**

**Solutions**

WWW.MKSINSTR.COM

# 740C & 750C

## GENERAL PURPOSE BARATRON® CAPACITANCE MANOMETERS

Today's industrial manufacturing processes require stability, repeatability, and accuracy in measuring pressure and vacuum. MKS has applied its expertise in capacitance sensor design to the 740C and 750C compact Baratron® capacitance manometers for use in industrial, analytical, and electronic measurement applications. The flexible product design makes it ideal either for new processing systems or for retrofits into existing processing systems.

The 740C and 750C Baratron capacitance manometers are rugged, industrial-grade pressure and vacuum transducers that use MKS proprietary sensor and electronics designs for superior accuracy, repeatability, and long-term signal stability. All exposed sensor surfaces are made from Inconel® nickel alloys for exceptional resistance to corrosion from a wide variety of aggressive chemicals. The sensor is also fully welded, guaranteeing safety to equipment operators from accidental exposure to dangerous chemicals. This advanced sensor and its electronics are mounted in a rugged stainless steel enclosure that can withstand harsh environments.

The 740C product is referenced to atmospheric pressure, and thus offers Full Scale measurement ranges from 20 to 3000 psig (1.4 to 204 bar). The 750C is an absolute transducer (referenced to high vacuum), and thus offers Full Scale measurement ranges from 10 Torr (13 mbar) to 3000 psia (204 bar). Both products are available with a wide variety of fittings, output signals, and electrical connectors for maximum configurability.

### Features & Benefits

- Self-contained sensor and signal conditioner in a compact and rugged enclosure
- All-welded Inconel sensor construction allows for use with most corrosive media
- Proven MKS capacitance technology yields a measurement resolution of 1 part in 10,000
- Signal outputs available as two-wire 4-20 mA, 0-5VDC, or 0-10VDC
- Overpressure limit of two times Full Scale or 45 psia (whichever is greater) with no degradation in performance
- Available with absolute (referenced to vacuum) or gage (referenced to atmosphere) calibrations



## Theory of Operation

MKS transducers are based on capacitance manometer technology and contain a sensor and signal conditioner. The sensor is made up of a tensioned metal diaphragm, one side of which is exposed to the media whose pressure is to be measured. The other (reference) side contains an electrode assembly placed in a reference cavity (see Figure 1). Absolute transducers have the reference side factory-sealed to a high vacuum ( $10^{-7}$  mmHg). For gage units, the reference side is open to atmosphere. The diaphragm deflects with changing pressure — force per unit area — causing a capacitance change between the diaphragm and the adjacent electrode assembly. The high level output signal, current, or DC voltage is linear with pressure, amplified, and self-compensated for thermal stability with ambient temperature changes. Capacitance manometers should be zeroed on installation. This zero adjustment has no effect on the actual calibration; it is similar to adjusting a dial gage to zero psig at the prevailing barometric pressure.

## Accuracy

The accuracy of the 740/750 Series is specified as percent of Reading, and includes hysteresis and non-linearity. Since many processes operate at pressures somewhere below Full Scale, the percent of Reading specification provides greater accuracy at the operating pressure. (See Figure 2)

Unlike strain gages, whose accuracy and reliability are a function of the precision of the gage itself and how well it is bonded to the surface, MKS pressure transducers are not subject to the additional uncertainties caused by the bonding. MKS capacitance-based pressure transducers have proven their accuracy and repeatability in application after application. The capacitance design is also much less susceptible to temperature changes.

## Repeatability

In order to maintain repeatable manufacturing processes, day to day, month after month, a pressure measurement source that will provide reliable and repeatable outputs on a continuous basis with the lowest possible error is needed. The 740/750 Series General Purpose Pressure Transducers have a repeatability specification of  $\pm 0.1\%$  of Reading. It is this percentage of Reading specification that gives end-users tighter process control (smaller deviations) over percent of Full Scale error — especially useful in applications requiring higher accuracy at the lower ends of the pressure measurement range.

## Compound Calibration

MKS offers compound calibration on 740 Series gage pressure units. Compound calibration utilizes a single transducer to measure a composite of pressure and vacuum. More simply defined, this is the ability to measure pressure above and below barometric pressure. Compound calibration allows the user to evacuate a container or chamber to a vacuum and then backfill to a specified pressure.

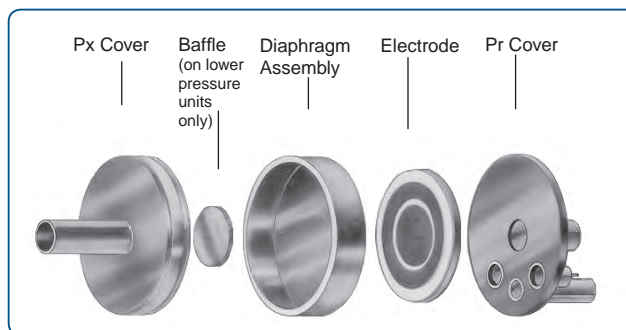

Figure 1 —  
An exploded diagram of an MKS pressure sensor

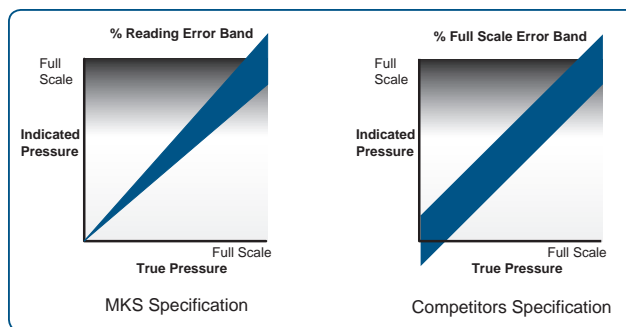

Figure 2 —  
Comparison of MKS accuracy expressed as percent of Reading versus competitors' accuracy as percent of Full Scale

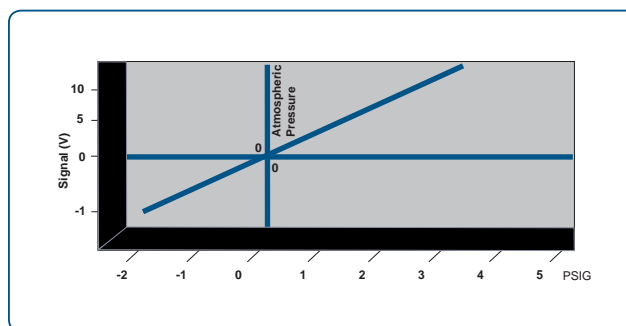

Figure 3 —  
Compound Calibration



# Specifications

	Absolute	Gage
<b>Media</b>	Gas, Liquid	Gas, Liquid
<b>Pressure Ranges</b>	10 Torr (13 mbar) to 3000 psia (204 bar)	20 to 3000 psig (1.4 to 204 bar)
<b>Accuracy</b> (includes non-linearity, hysteresis and non-repeatability)	±1% Reading 0.1% Full Scale	±1% Reading 0.1% Full Scale
<b>Repeatability</b>	±0.1% of Reading	±0.1% of Reading
<b>Resolution</b> (output)	0.01% of Full Scale	0.01% of Full Scale
<b>Ambient Operating Temperature</b>	0° to 50°C	0° to 50°C
<b>Temperature Effect</b>		
Zero	0.02% of Full Scale/°C	0.02% of Full Scale/°C
Span	0.04% of Reading/°C	0.04% of Reading/°C
<b>Response Time</b>	<20 msec	<20 msec
<b>Excitation</b>		
0-5 VDC output	+13 to 32 VDC @ 10 mA max.	+13 to 32 VDC @ 10 mA max.
0-10 VDC output	+13 to 32 VDC @ 10 mA max.	+13 to 32 VDC @ 10 mA max.
4-20 mA output	+13 to 32 VDC (Rated Class I, Div. II, Groups A & B as an option)	+13 to 32 VDC (Rated Class I, Div. II, Groups A & B as an option)
<b>Electrical Termination</b>	9-pin D-subminiature Bendix PTO 4-Pin 6 ft (2m) flying lead	9-pin D-subminiature Bendix PTO 4-Pin 6 ft (2m) flying lead
<b>Overload-Safe</b>	45 psia or 2x Full Scale, whichever is greater	45 psig or 2x Full Scale whichever is greater
<b>Overload-Burst</b>		
up to 1000 psi Full Scale	100 psia or 10x Full Scale whichever is greater	100 psig or 10x Full Scale whichever is greater
>1000 psi Full Scale	5x Full Scale	5x Full Scale
<b>Internal Volume</b>		
Single-ended	0.3 cu. in.	0.3 cu. in.
<b>Wetted Parts Material</b>	Inconel and 316L S.S.	Inconel and 316L S.S.
<b>Weight</b>		
Single-ended	0.5 lbs (0.2 kg)	0.5 lbs (0.2 kg)
<b>Compliance</b>	CE	CE



# Ordering Information

## Ordering Code Example: 750C33PFA2GA

740C/750C Baratron Pressure Transducers	Code	Configuration
Gage Single-ended Transducer	740C	750C
Absolute Single-ended Transducer	750C	

### Pressure Ranges

**Gage** (For compound calibrations, consult Applications Engineering)

20 psig	21P
50 psig	51P
100 psig	12P
200 psig	22P
250 psig	RDP
500 psig	52P
1000 psig	13P
2000 psig	23P
3000 psig	33P

### Absolute

10 mmHg	11T
20 mmHG	21T
50 mmHg	51T
100 mmHg	12T
200 mmHg	22T
500 mmHg	52T
1000 mmHg	13T
2000 mmHg	23T
3000 mmHg	33T
20 psia	21P
50 psia	51P
100 psia	12P
250 psia	RDP
500 psia	52P
1000 psia	13P
2000 psia	23P
3000 psia	33P

### Fittings

1/2" OD Tube*	BA
1/4" OD Weld Stub	BB
4 VCR® Male	CB
4 VCR Female	CD
8 VCR Female	CE
8 VCO® Female	DA
1/4" NPT Female**	FA
1/4" NPT Male**	FB
1/8" NPT Female**	FF
1/8" NPT Male**	FE
NW-16KF*	GA
1.33" OD Conflat****	HA

### Input/Output

+13 to 32 VDC input/0– 10VDC output	2
+13 to 32 VDC input/0– 5VDC output	3
+13 to 32VDC excitation/4–20 mA output	4

### Accuracy

1.0% of Reading	G
0.1% Full Scale (Best Fit Straight Line)	R

### Connector

9-pin male D-subminiature	A
15-pin male high-density D-subminiature	C
9-pin D-subminiature on flying lead	G
4-pin Bendix PTO	D
Flying Leads – 6 ft (2 m)	F
Flying Lead with 15-pin male D-subminiature	K

\*Available only on Full Scale ranges of 1000 Torr or less

\*\*Not available for 10 or 50 Torr full-scale ranges

\*\*\*Available only for full-scale ranges of 1000 psi or less

## MKS Instruments, Inc. Global Headquarters

2 Tech Drive, Suite 201  
Andover, MA 01810  
Tel: 978.645.5500  
Tel: 800.227.8766 (in U.S.A.)  
Web: www.mksinst.com

## MKS Instruments, Inc. Pressure & Vacuum Measurement Solutions

Six Shattuck Road  
Andover, MA 01810  
Tel: 978.975.2350

### 9-PIN TYPE "D"

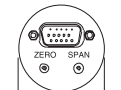

### BENDIX



1.50(38.1 MM)  
DIA

### FLYING LEADS

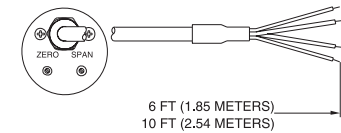

6 FT (1.85 METERS)  
10 FT (2.54 METERS)

### SINGLE-ENDED

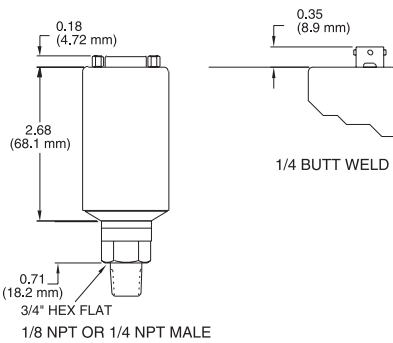

### Dimensional Drawing —

Note: Unless otherwise specified, dimensions are nominal values in inches (mm referenced).



740C/750C - 3/19  
© 2009-2019 MKS Instruments, Inc.  
All rights reserved.

Some Baratron® capacitance manometer products may not be exported to many end user countries without both US and local government export licenses under ECCN 2B230.

Specifications are subject to change without notice. mksinst is a trademark and Baratron® is a registered trademark of MKS Instruments, Inc., Andover, MA. Inconel® is a registered trademark of Inco Alloys International, Huntington, WV. Bendix® is a registered trademark of Amphenol Corp., Bendix Connector Operations, Sydney, NY. VCR® and VCO® are registered trademarks of Swagelok Co., Willoughby, OH. Conflat® is a registered trademark of Varian Associates, Inc., Lexington, MA.