



SRG-3

SPINNING ROTOR GAUGE SYSTEM

The Spinning Rotor Gauge (SRG) line is well established with users around the world as a stable, high accuracy transfer standard for high vacuum pressure measurements. We continue to be at the forefront of SRG development with the introduction of the SRG-3 Spinning Rotor Gauge System.

The complete SRG-3 system is comprised of a microprocessor-based electronics unit, a measuring head and a ball/flange assembly. The measuring head easily decouples from the ball/flange assembly, allowing several permanently mounted ball/flange assemblies to be used with one measuring head and electronics unit. This facilitates taking measurements from multiple locations when continuous readings are not necessary.

Features & Benefits

Traceability

- German Calibration Service, DKD traceable
- Ensures absolute consistency
- Recognized transfer standard

Accuracy

- Guaranteed precision from 5×10^{-7} to 1×10^{-2} mbar (Torr)
- Overall measuring range extends to 1 mbar (Torr)
- No thermal or ionization effects

Stability

- Superior long term stability
- Wetted surfaces are stainless steel
- Assures chamber-to-chamber consistency



Principle of a Spinning Rotor Gauge

The sensing element of the SRG is a magnetically levitated stainless steel ball that resides in a tube connected to the vacuum system. The ball is suspended and rotated by the separable drive assembly. Once the ball reaches a certain rotational speed, the ball is allowed to free spin. Collisions of the gas molecules with the surface of the ball impart a drag which decelerates the ball. Pickup coils measure the deceleration. The electronics unit then uses an algorithm based on the sampling time, physical parameters and gas characteristics to accurately determine the pressure.

Since the measurement principle is mechanical, there are no thermal or ionization effects (as is the case with ionization gauges) that will influence the accuracy of the measurements. Also, the calibration constant is only weakly influenced by the ball's surface roughness, making the SRG a very stable reference standard.

The SRG-3 will find applications in metrology and in experiments where high accuracy and repeatability are essential. Away from the test bench, the MKS Spinning Rotor Gauge may also be used in situ on a process chamber to assure high vacuum gauge reading accuracy and tool-to-tool consistency. This provides repeatable process results, high uptime and optimum cycle times.

MKS Instruments, Inc. delivers the SRG-3 with a calibrated measuring head and ball/flange assembly along with a calibration certificate. Calibration is made against the reference standards of our DKD1 calibration laboratory. As a result, the Spinning Rotor Gauge SRG-3 system offers the user consistent traceability as required for ISO9000.

Should measuring flanges with non-calibrated balls be ordered, they will be checked for usability by the factory.

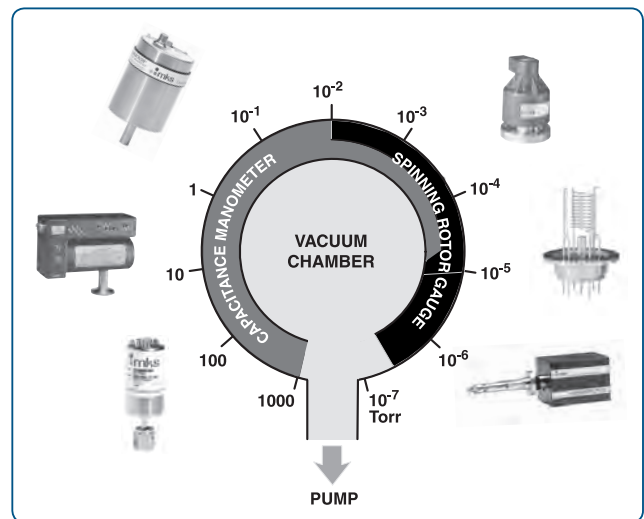

Calibration, Traceability, Stability —

In addition to the SRG-3, MKS Instruments offers transfer standard Baratron® capacitance manometers to meet all of your needs for vacuum gauge calibration.

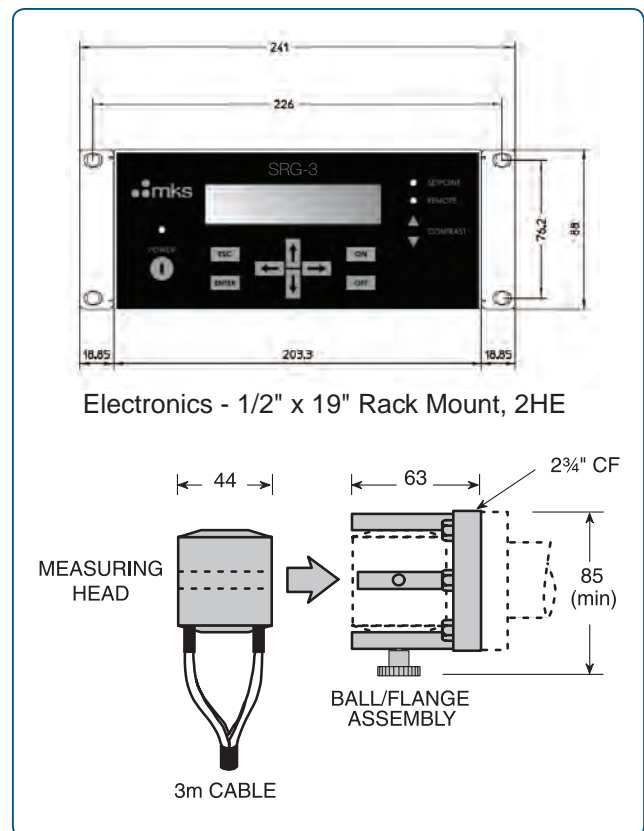

Dimensional Drawing —

Note: Unless otherwise specified, dimensions are nominal values in millimeters.



Specifications

Measuring Range	5x10 ⁻⁵ to 100 Pa
Accuracy up to 1 Pa 1 to 100 Pa	1% of measuring value + U; U expresses the residual drag variation increasing up to 10% of measured value (typical)
Long-Term Stability	Better than 1% per year
Display	4½ digit LCD display
Pressure Display	Pa, mbar, or Torr; user selectable
Display Format	Scientific notation
Analog Output	0-10 VDC, into 2kΩ min. load, linear or logarithmic
Switching Points	2 SPDT relays, adjustable, nominal switching capacity (resistive load): 1A 30VDC, 0.5A 25VAC eff
Digital Interface	(a) RS-232; (b) USB (USB 2.0 compatible)
Measuring Flange	2¾ CF, made of stainless steel, bakeable up to 450°C (without measuring head)
Rotor	Stainless steel ball, 4.5 mm in diameter (nominal)
Operating Temperature	Electronics: 10-40°C; measuring head: 10-50°C; ball/flange assembly bakeable to 450°C
Enclosure	Half 19-inch rack mount or table top ; 241mm x 185 mm x 88 mm (BxDxH)
Weight	Electronics: 2.5kg; measuring head: 0.6kg; measuring flange: 0.5kg
Operating Voltage	85-256 VAC, 47-63 Hz
Wetted Materials	Ball and Flange
Programming Features	15 programmable data sets to minimize set up time; database of 17 frequently used gases with the option for the user to add 8 additional gases
Compliance	CE



Ordering Information

SRG-3 Spinning Rotor Gauge

SRG3-EL	Electronic Control Unit
SRG-SH700-V3	Measuring head with 3m long cable
SRG-BF-CAL	Ball/Flange Assembly, calibrated
SRG-BF	Ball/Flange Assembly, not calibrated

The sense/drive head and ball/flange assembly of the SRG-3 are compatible with the former Spinning Rotor Gauge Types SRG-2 and SRG-2CE.

Accessories

001-8483	External printer option
095-103390	Printer cable



MKS Instruments, Inc. Global Headquarters

2 Tech Drive, Suite 201
Andover, MA 01810
Tel: 978.645.5500
Tel: 800.227.8766 (in USA)
Web: www.mksinst.com

MKS Instruments, Inc. Pressure & Vacuum Measurement Solutions

6450 Dry Creek Parkway
Longmont, CO 80503
Tel: 303.652.4400