

PR 4000B-F

2 Channel Power Supply and Readout for Flow and Pressure

Instruction Manual

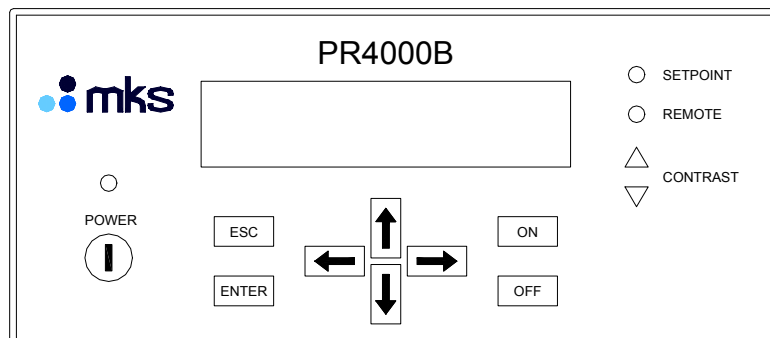

Copyright © 2008 by MKS Instruments Deutschland GmbH

All rights reserved. No part of this work may be reproduced or transmitted in any form or by any means, electronic or mechanical, including photocopying and recording, or by any information storage or retrieval system, except as may be expressly permitted in writing by MKS Instruments.

Printed in the Federal Republic of Germany

Table of Contents

Safety Information	9
Symbols Used in This Instruction Manual.....	9
Safety Procedures and Precautions	10
Chapter 1: General Information.....	11
1.1 General Description	11
1.2 Customer Support.....	12
1.3 Intended Use.....	12
Chapter 2: Installation	13
2.1. Unpacking.....	13
2.2. Unpacking Checklist	13
2.3. Cables.....	14
Interconnection Cables from MKS.....	14
Generic Shielded Cable Description.....	15
2.4 Installation, Mounting.....	16
Rack Mounting or Table Top?	16
Dimensions	17
Line Power and Fuses	18
2.5 Switching on the unit.....	18
Chapter 3: Overview.....	19
3.1 Front Panel	19
3.2 Rear Panel	20
Connections	20
3.3 Connectors.....	21
Channel 1 / Channel 2	21
EXTERN	21
ACCESS	22
RELAY	22
RS232	23
RS485	23
Chapter 4: Operation.....	25
4.1 Structure of the Menu	25
4.2 Editor.....	26
Switching on Edit mode	26
Switching off Edit mode	26
Decimal point	26

4.3	Setup.....	27
	Entering Setup	27
	Configuration of display 1 and display 2.....	28
	Configuration of display 3 and display 4.....	28
	Setpoint.....	29
	Range.....	29
	Gain and Offset.....	30
	Range Turndown Offset.....	30
	Input Signal Range and Output Signal Range.....	31
	Signalmode	32
	Linearization.....	34
	Trip Limits.....	35
	Limit-Mode:	35
	Temporary Criteria	36
	Interface RS232	37
	Interface RS485	37
	Exit Setup.....	38
4.4.	Control.....	39
	Display for measurement values and setpoints.....	39
	Status Displays	40
	Control Display.....	40
	Note.....	41
4.5.	Operation with pressure transducers.....	41
	Operation with Baratron Type 120.....	42
	Range Turndown	42
	Example for a type 120, 1 mbar full scale.....	42
4.6.	Operation with mass flow controllers (MFC).....	43
	Control Modes with Mass Flow Controllers:	43
4.7.	Operation with flow meters	44
4.8.	Operation with pressure controllers.....	44
4.9.	Limit switches and relays	45
	SLEEP	45
	LIMIT	45
	BAND	45
	MLIMIT	45
	MBAND	45
4.10.	Relay Settings.....	46
Chapter 5:	Interface.....	47
5.1.	General	47
5.2.	Command syntax	47

5.3.	Reply syntax	48
5.4.	Error reply syntax.....	48
5.5	Commands.....	49
	Sample Command.....	49
	Display Text (DT).....	49
	Request Key (KY).....	49
	Dialog (DG).....	50
	ID String (ID).....	50
	Remote Mode (RT).....	50
	Access Channel (AC).....	50
	Actual Value (AV).....	51
	Setpoint (SP).....	51
	External Input (EX).....	51
	Status (ST).....	51
	Valves (VL).....	52
	Relays (RL).....	52
	Displays (DP).....	52
	Display 4 (DP4).....	52
	Range (RG).....	53
	Gain (GN).....	53
	Offset (OF).....	53
	RTD Offset (RO).....	53
	Autozero (AZ).....	54
	Input Range (IN).....	54
	Output Range (OT).....	54
	External Input Range (EI).....	54
	External Output Range (EO).....	54
	Signal Mode (SM).....	55
	Scale (SC).....	55
	Linearization (LN, LS).....	55
	Limit Mode (LM).....	55
	Dead Band (DB).....	56
	Upper Limit (UL).....	56
	Lower Limit (LL).....	56
	Formula Relay (FR).....	56
	Formula Temporary (FT).....	57
	Parity (PY).....	57
	Baudrate (BD).....	57
	Address (AD).....	57
	Interface Mode (IM).....	57

Resolution (RS).....	58
Reset Status (RE).....	58
Default (DF)	58
Unlock (#0).....	58
Lock (#1)	58
Tweak Control (\$0, \$1, ?\$)	58
Appendix A: Specifications	59
Appendix B: Error Messages.....	61
Appendix C: Default – Configuration	63
Appendix D: Dialog Reference	65
MKS Worldwide Calibration & Service Centers	67

List of Figures

Figure 1: Rack angles assembly	16
Figure 2: Rubber feet assembly	16
Figure 3: Dimensions	17
Figure 4: Front Panel.....	19
Figure 5: Rear Panel	20
Figure 6: Structure of the menu	25

List of Tables

Table 1: Standard Interconnecting Cables.....	15
Table 2: Fuse Information	18

This page left blank.

Safety Information

Symbols Used in This Instruction Manual

Definitions of WARNING, CAUTION, and NOTE messages used throughout the manual.

Warning



The **WARNING** sign denotes a hazard. It calls attention to a procedure, practice, condition, or the like, which, if not correctly performed or adhered to, could result in injury to personnel.

Caution



The **CAUTION** sign denotes a hazard. It calls attention to an operating procedure, practice, or the like, which, if not correctly performed or adhered to, could result in damage to or destruction of all or part of the product.

Note



The **NOTE** sign denotes important information. It calls attention to a procedure, practice, condition, or the like, which is essential to highlight.

Safety Procedures and Precautions

The following general safety precautions must be observed during all phases of operation of this instrument. Failure to comply with these precautions or with specific warnings elsewhere in this manual violates safety standards of intended use of the instrument and may impair the protection provided by the equipment. MKS Instruments assumes no liability for the customer's failure to comply with these requirements.

DO NOT SUBSTITUTE PARTS OR MODIFY INSTRUMENT

Do not install substitute parts or perform any unauthorized modification to the instrument. Return the instrument to an MKS Calibration and Service Center for service and repair to ensure that all safety features are maintained.

SERVICE BY QUALIFIED PERSONNEL ONLY

Operating personnel must not remove instrument covers. Component replacement and internal adjustments must be made by qualified service personnel only.

GROUND THE PRODUCT AND USE PROPER ELECTRICAL FITTINGS

Dangerous voltages are contained within this instrument. All electrical fittings and cables must be of the type specified, and in good condition. All electrical fittings must be properly connected and grounded.

This product is grounded through the grounding conductor of the power cord. To avoid electrical shock, plug the power cord into a properly wired receptacle before connecting it to the product input or output terminals. A protective ground connection by way of the grounding conductor in the power cord is essential for safe operation.

DANGER ARISING FROM LOSS OF GROUND

Upon loss of the protective-ground connection, all accessible conductive parts (including knobs and controls that may appear to be insulating) can render an electrical shock.

USE THE PROPER POWER CORD

Use only a power cord that is in good condition and which meets the input power requirements specified in the manual.

Use only a detachable cord set with conductors that have a cross-sectional area equal to or greater than 0.75 mm². The power cable should be approved by a qualified agency such as VDE, Semko, or SEV.

Chapter 1: General Information

1.1 General Description

The control unit PR4000B is designed for the use with mass flow controllers (MFC), mass flow meters (MFM), pressure transducers and in-line-pressure controllers, e.g. type 640 from MKS Instruments. Compatibility is just restricted in case of disagreement of electrical specifications.

The PR4000B is available as single or dual channel power supply, readout and control unit. This instruction manual however describes only the dual channel version PR4000B-F (single channel version: PR4000B-S). Two or more units PR4000B can be combined thus performing multichannel control units.

Further features:

- Display with four or five digits, selectable
- 2 trip limits and 2 relays, can be combined and configured in a wide variety of functions and combinations
- linearization possible for both channels
- Interface either RS232 (standard) or RS485 (optional)
- 2 different power supplies: $\pm 15\text{ V} / 1,5\text{ A}$ or $24\text{ V} / 1\text{ A}$
- two line display, configurable, allows simultaneous readout of both channels or one channel actual value plus setpoint
- physical values displayed with engineering units
- non volatile memory for easy restart after power loss or switching off power

For more details and specifications refer to Appendix A, *Specifications*

1.2 Customer Support

Standard maintenance and repair services are available at all of our regional MKS Calibration and Service Centers, listed on the last page. In addition, MKS accepts the instruments of other manufacturers for recalibration using the Primary and Transfer Standard calibration equipment located at all of our regional service centers. Should any difficulties arise in the use of your PR4000B-F, or to obtain information about companion products MKS offers, contact any authorized MKS Calibration and Service Center. If it is necessary to return the instrument to MKS, your service center can inform you about the need for an ERA Number (Equipment Return Authorization Number) or a form for declaration of decontamination or any other regulations before shipping. The ERA Number expedites handling and ensures proper servicing of your instrument.

Please refer to the last page of this manual for a list of MKS Calibration and Service Centers.

Warning



All returns to MKS Instruments must be free of harmful, corrosive, radioactive, or toxic materials.

1.3 Intended Use

The PR4000B is a power supply and readout unit for operation of MKS mass flow meters, mass flow controllers, pressure transducers and in-line pressure controllers. Combination with units of other manufacturers may be possible given operating specifications that match MKS hardware requirements. However, MKS Instruments does not guarantee any warranty for these system configurations, and will not be liable for any consequential or incidental damages occurring through these combinations.

Chapter 2: Installation

2.1. Unpacking

MKS has carefully packed the Type PR4000B unit so that it will reach you in perfect operating order. Upon receiving the unit, however, you should check for defects, cracks, broken connectors, etc., to be certain that damage has not occurred during shipment.

Note



Do not discard any packing materials until you have completed your inspection and are sure the unit arrived safely.

If you find any damage, notify your carrier and MKS immediately. Please refer to the last page of this manual for a list of MKS calibration and service centers.

Caution



Only qualified individuals should perform the installation and any user adjustments. They must comply with all the necessary ESD and handling precautions while installing and adjusting the instrument. Proper handling is essential when working with all highly sensitive precision electronic instruments.

2.2. Unpacking Checklist

Standard Equipment:

- PR4000B-F power supply & readout unit
- 4 rubber feet for tabletop use
- Power cable
- Mating connector kit
- Instruction manual (this book)

Optional:

- Connection cable(s), e.g. for transducers, controllers etc.

2.3. Cables

The unit complies with the European standards and thus it is labelled with the CE-mark. To fulfill the above listed guidelines it is mandatory to use the appropriate interconnection cables.

Note



The instrument complies to EN 61326-2-2 with the requirements for industrial applications. Braided shielded cables must be used.

We recommend to use the cables offered by MKS Instruments.

Cables which are in compliance with the CE guidelines are marked with an „E“ or „S“ (example: CB259E-... or CB259S-...).

Interconnection Cables from MKS

The following table lists the standard cables provided by MKS Instruments. They are all in compliance with the CE guidelines. If the cable needed for your particular instruments is not listed there then please contact your MKS center.

The cable length is 3 meters (standard length), 5 m or 10 m (optional).

For cable length greater than 10 m please contact your MKS center.

(continued on next page)

Cables for combination with the PR4000 with +/- 15 VDC power supply¹	
For pressure transducers or in-line pressure controllers type or series	MKS-Cable Type
120	CBE 120-96-3M
121	CBE 112-14-3M
622, 623, 624, 625, 223, 122A	CBE 112-2-3M
621, 626, 627, 628, 127, 128, 722A (with 15-pin type D connector)	CBE 259-5-3M
722 (9-pin type D connector)	CBE 700-1-3M
722 (terminal block)	CBE 700-99-3M
For mass flow meters (MFM) or mass flow controllers (MFC)	
mit 15-pin type D connector: 179, 1179, 2179, 1479, 1259, 2259, 258, 358, 1359, 558, 1559, M100	CBE 259-5-3M
mit 9-pin type D connector: 1179, 2179, 1479, M200, M330	CBE147-12-3M

Table 1: Standard Interconnecting Cables with PR 4000 with +/- 15 VDC power supply

Note

Flow controllers with 9-pin connector do not have the „Valve Close“ input (remotely closing of the control valve).

Generic Shielded Cable Description

MKS offers a full line of cables for all MKS equipment. Should you choose to manufacture your own cables, follow the guidelines listed below:

1. The cable must have a *braided* shield, covering all wires. Neither aluminum foil nor spiral shielding will be as effective; using either may nullify regulatory compliance.
2. The connectors must have a metal case which has direct contact to the cable's shield on the whole circumference of the cable. The inductance of a flying lead or wire from the shield to the connector will seriously degrade the shield's effectiveness. The shield should be grounded to the connector before its internal wires exit.
3. With very few exceptions, the connector(s) must make good contact to the device's case (ground). "Good contact" is about 0.01 ohms; and the ground should surround all wires. Contact to ground at just one point may not suffice.
4. For shielded cables with flying leads at one end; it is important at such end, to ground the shield *before* the wires exit. Make this ground with absolute minimum length. After picking up the braid's ground, keep wires and braid flat against the case. With very few exceptions, grounded metal covers are not required over terminal strips. If one is required, it will be stated in the Declaration of Conformity or in the instruction manual.

¹ For connection cables for the PR4000 with 24 VDC power supply please contact MKS.

5. In selecting the appropriate type and wire size for cables, consider:
 - a. The voltage ratings;
 - b. The cumulative I^2R heating of all the conductors (keep them safely cool);
 - c. The IR drop of the conductors, so that adequate power or signal voltage gets to the device;
 - d. The capacitance and inductance of cables which are handling fast signals, (such as data lines or stepper motor drive cables); and
 - e. That some cables may need internal shielding from specific wires to others; please see the instruction manual for details regarding this matter.

2.4 Installation, Mounting

The PR4000B-F is designed for use in dry and warm environment with sufficient ventilation. The device must be installed in such a way that air can circulate free. Do not cover the openings at the instrument's housing. If there are heat loss generating devices located next to the unit make sure that no excessive heat is transferred to the unit.

Rack Mounting or Table Top?

The PR4000B fits to a 19" half rack or on top of a table. Three screws on each side allow dis-/assembling of the rack angles. Rubber feet give the device a stable stand on a table. (Screws are TX10)



Figure 1: Rack angles assembly



Figure 2: Rubber feet assembly

Note



Position the unit with proper clearance to allow air cooling, so that the unit can operate within the specified temperature as listed in appendix A. Do not cover the openings at the instrument's housing.

Dimensions

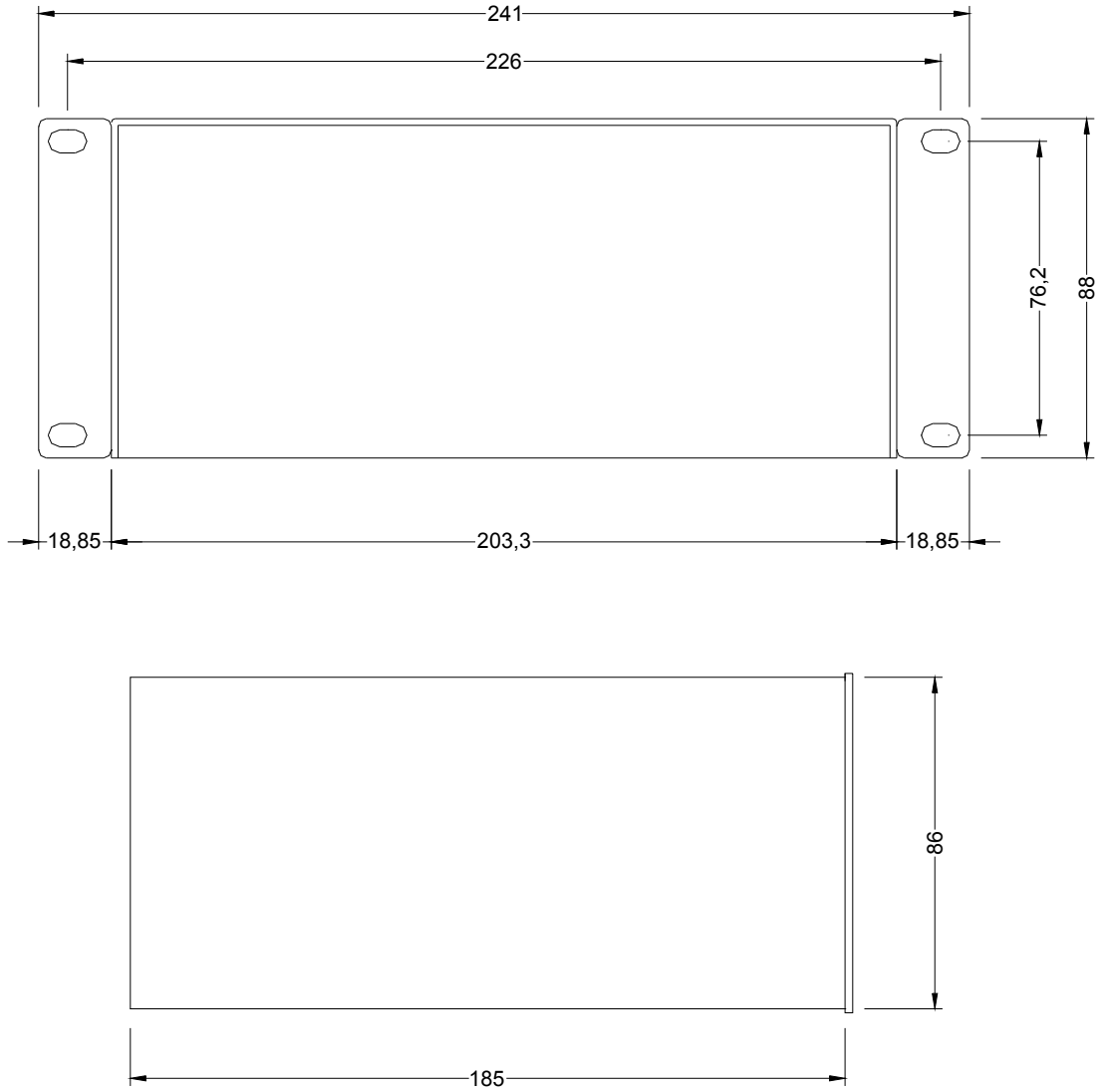

Figure 3: Dimensions
(above: Front and Rear Panel; below: Side View)

Line Power and Fuses

Line cord plug, the holder for the line fuse and the fuses of the power supply output are located at the rear panel (see figure 4).

Refer to the following table in case that the line fuses must be changed or replaced

Fuse	Type
Line	1,25 A Slow Blow
Process Power F1, F2	Wickmann (Little Fuse), No.372 / TR5, 1.6Amp

Table 2: Fuse Information

Use only fuses as specified in table 2. Before replacing any fuse the failure that caused the blow must be identified and eliminated. Do not open the housing! In any case of trouble switch the unit off and disconnect the line power cable from the PR4000B. Do not perform any internal repair but contact MKS for service.

To replace the line fuse lift the fuse holder using a screwdriver with small blade. There is a spare fuse placed in the holder. The power output fuses F1 and F2 are being replaced by pulling them off the rear panel (tightly grabbing with two fingers).

Caution



Separate the instrument completely from mains before replacing any fuse!

Make sure the fuse type applies to the specifications given in this manual.

Protective Grounding

Connect the power cord PR4000B only to a properly grounded outlet.

2.5 Switching on the unit

After all connections to the peripheral instruments, e.g. pressure transducer, mass flow controller etc. are properly done the unit can be switched on. Refer to the instructions for the peripheral units for proper installation, connection, set up and warm up.

The elements on the front and rear panel and their functions are explained in the following chapter.

Chapter 3: Overview

3.1 Front Panel

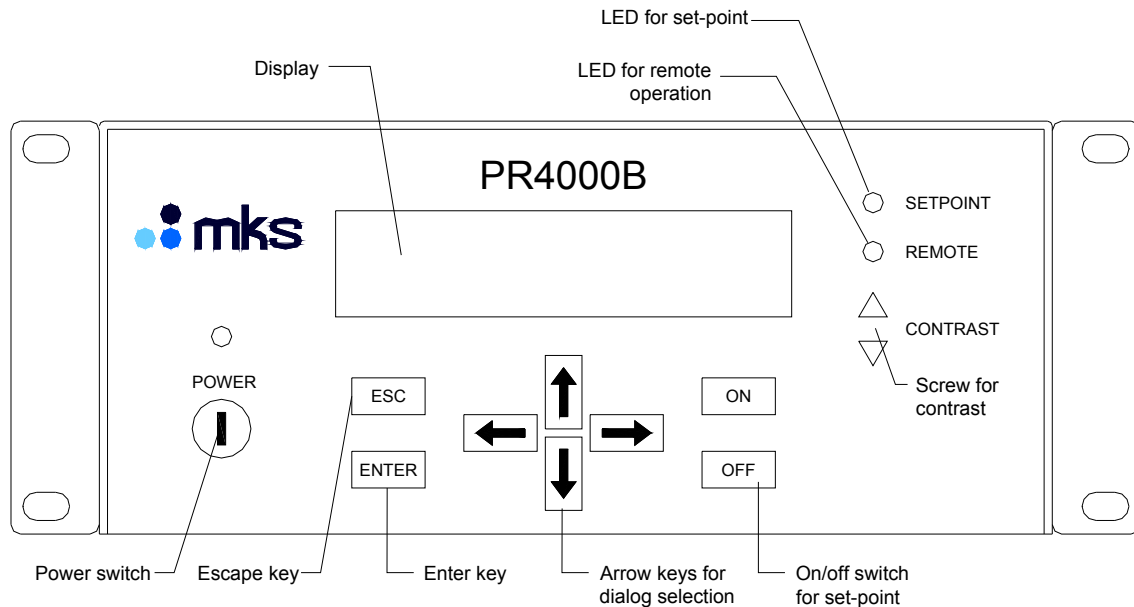

Figure 4: Front Panel

Display:	Two lines. Each line 16 characters. Simultaneous readout for both channels possible.
POWER	Button switch toggles between standby and operation. For total breakup from mains use switch on the rear side. The LED above indicates the device in operation.
ENTER	Accepts and stores entered data.
ESC (Escape)	Switches stepwis back finally to display #1 mode.
Arrow buttons	Navigation in the menus
ON , OFF	Switches the setpoint output. Note: Channel valve switch (channel preselection) must be activated for setpoint output.
SETPOINT	LED, lit when setpoint output active.
REMOTE	LED, lit when unit is operated through serial interface.
CONTRAST	Allows adjustment of display contrast.

3.2 Rear Panel

The rear panel provides all connectors, the fuse holder and the receptable for the line voltage cable.

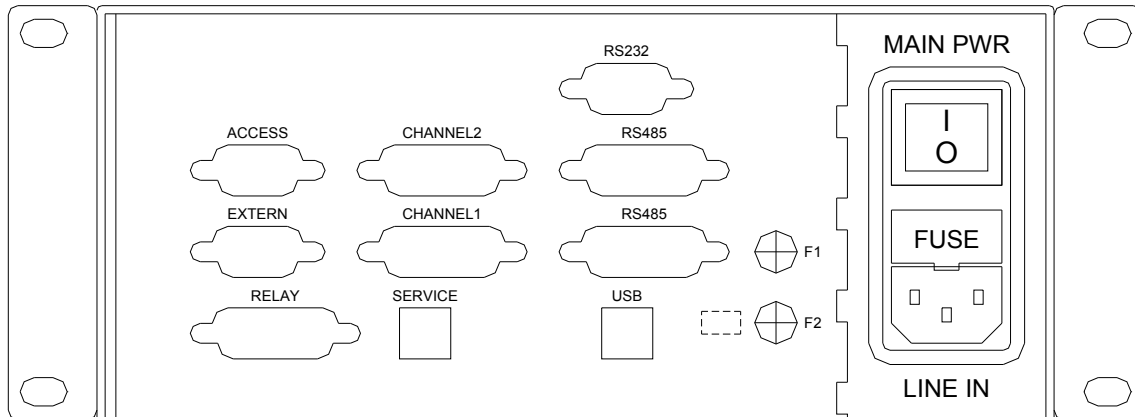

Figure 5: Rear Panel

Connections

ACCESS	Connector <i>ACCESS</i> . Direct access to the pins for inputs and outputs of signals of measurement , setpoint and controls of the connectors CHANNEL 1 and CHANNEL 2.
EXTERN	This connection is used to input external analog setpoint signals and to monitor measurement signals of both channels.
RELAY	Access to the contacts of both relays.
CHANNEL 1	Connection for pressure transducer, mass flow controller etc. to channel 1
CHANNEL 2	Connection for pressure transducer, mass flow controller etc. to channel 2
RS232	Serial Interface RS232
RS485	Serial Interface RS485
SERVICE	Service and Diagnostics (used only by MKS)
USB	No connection
LINE IN	Receptable for line power cord
MAIN PWR	I = On; unit can be toggled on and off by front panel button switch
F1, F2	Fuses for process power output ± 15 V or 24 V, respectively
FUSE	Line fuse

For detailed information to fuses refer to chapter 2 *Line Power and Fuses*.

3.3 Connectors

Channel 1 / Channel 2

These connectors serve to connect pressure transducers, flow meters, flow or pressure controllers to the unit.

15-pin., Sub-D, Socket

Pin	Function	Pin	Function
1	reserved	9	reserved
2	Signal Input	10	reserved
3	Flow controllers: Valve Close Baratron type 120: Range Turndown	11	Signal ground for pin 2 and pin 8
4	Valve Override	12	same as pin 11
5	± 15 V Common or 24 V Ground*	13	reserved
6	- 15 V	14	reserved
7	+ 15 V or + 24 V*	15	Chassis ground
8	Setpoint output		

*) depending on model

EXTERN

This connector is preferable used to monitor the flow or pressure signal of the device connected to the respective channel and / or to feed an external setpoint voltage into the instrument.

9-pin., Sub-D, Socket

Pin	Function	Pin	Function
1	External setpoint to CH 1	6	Signal input CH 1*
2	External setpoint to CH 2	7	Signal input CH 2*
3	Signal output CH 1	8	Signal ground for pin 1, 3, and 6**
4	Signal output CH 2	9	Signal ground for pin 2, 4 and 7**
5	± 15 V Ground		

*) Identical to Pin 2 of the corresponding channel connector

***) Identical to pin 11&12 of the corresponding channel connector

ACCESS

This connector provides access to different utility signals on the channel connectors, without the need of making a split cable. The access is a direct one, that means there is no electronic circuitry between and it may also be used for troubleshooting or override the control valve of a mass flow controller or in-line pressure controller.

9-pin. Sub-D, Socket

Pin	Function	Pin	Function
1	Channel 1, Pin 1	6	Channel 2, Pin 1
2	Channel 1, Pin 4	7	Channel 2, Pin 4
3	Channel 1, Pin 9	8	Channel 2, Pin 9
4	reserved	9	reserved
5	± 15 V Ground		

RELAY

15-pin.; Sub-D, Socket

Pin	Function	Pin	Function
1	Relay 1, Normally closed	9	Relay 1, Common
2	Relay 1, Normally open	10	Relay 2, Normally closed
3	Relay 2, Common	11	Relay 2, Normally open
4	reserved	12	reserved
5	reserved	13	reserved
6	reserved	14	reserved
7	reserved	15	reserved
8	+15 V Ground		

RS232

9-pin., Sub-D, Pin

Pin	Function	Pin	Function
1	No connection	6	No connection
2	RXD	7	No connection
3	TXD	8	No connection
4	No connection	9	No connection
5	GND		

RS485

15-pin., Sub-D

Pin	Function	Pin	Function
1	Shield	9	Send Data T + (Y)
2	Send Data T - (Z)	10	No connection
3	No connection	11	Receive Data R + (A)
4	Receive Data R - (B)	12	No connection
5	No connection	13	No connection
6	No connection	14	U2 = +15 V/24 V (optional)
7	GND 2 (optional)	15	U1 = +5 V (optional)
8	GND 2		

This page left blank.

Chapter 4: Operation

After switching on the power the following information is displayed for 2-3 seconds:



(here: Version 01.29 ; Oct. 11, 1999)

Then the unit switches automatically to display 1, which may be used for routine operation. This section describes how to configure the different displays and how to set the parameters for operation and control.

4.1 Structure of the Menu

The menu is divided in two levels:

1. Displays for standard operation. These displays show measurement values, setpoints, trip limit information etc.
2. Setup. Here the system configuration and the displays are set and parameters can be edited.

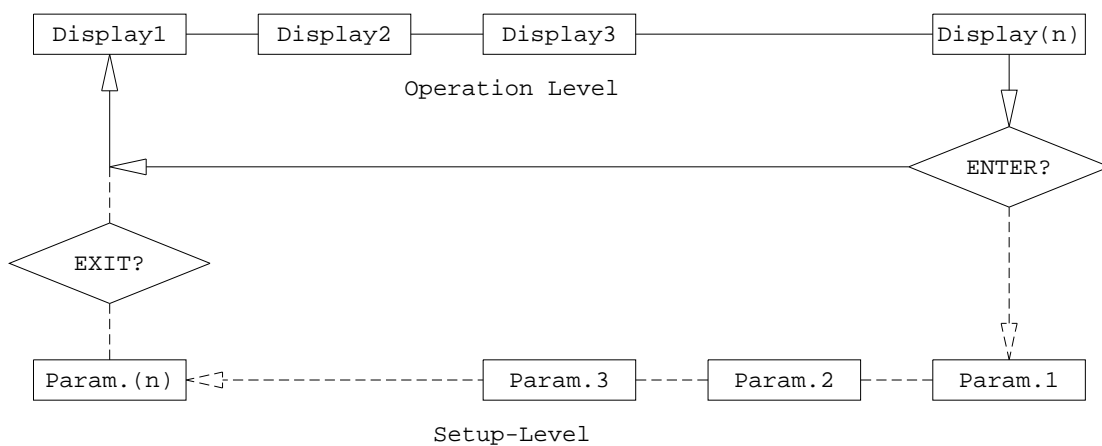

Figure 6: Structure of the menu

It is recommended to deactivate the entry into the setup (see figure 4) after all parameters have been edited. This allows quick switching through the 1 to 4 operational displays in a circular mode without stepping through all setup dialogs.

By pressing the escape key (ESC) one time it is easily possible to switch the unit back to the display #1 from any position in any level.

4.2 Editor

The PR4000B-F is operated and configured by dialogs (two-line LCD) or digital I/O (RS232/RS485). The dialogs are organized in a simple table hierarchy. All the dialogs can be accessed and displayed easily: you can change from one dialog to another using the up/down arrow keys or return to the main dialog at any time by pressing the ESC key. The dialog table is divided in two parts, an operation and a setup part.

Switching on Edit mode

Edit mode can be switched on or off in the dialogs. You can enter numeric values in Edit mode, alter variables, etc. There are two ways of switching on Edit mode:

1. With the ENTER key
2. With the left/right arrow keys \leftarrow or \rightarrow
3. When you switch on Edit mode, the cursor appears as a flashing underscore below the first or last alphanumeric character. You can move the cursor within a line using the left/right arrow keys or change the preset values with the up/down arrow keys.

If '9' is displayed and you press the up/down arrow keys again to scroll the number, the display automatically creates two digits ('10'); the same applies analogously in the opposite direction.

If, when you exit Edit mode by pressing the ENTER key, the value you have set is outside the valid range, the highest or lowest permitted value is stored instead.

Switching off Edit mode

You can switch off Edit mode again by pressing the ENTER key. The entered values are not stored until you press the ENTER key.

You can also exit Edit mode with the ESC key. In this case, however, the values are not stored.

Decimal point

You can mark the decimal point in this dialog with the left/right arrow keys and shift it with the up/down keys. The up arrow shifts the cursor to the left, while the down arrow shifts it to the right. The new decimal point setting takes effect in all the dialogs in which measured values or values directly referred to them are displayed. It does not affect device parameters, such as *Gain*.

4.3 Setup

It is recommended to check all parameters for correct settings before starting operation. Detailed information for operation of the different kind of transducers, controllers etc. are given later in this chapter. For understanding these instructions it is necessary to have studied the setup information before.

After switching on the power or pressing the escape key (ESC) you will see the first display configured for operation (typically display #1). By consecutively pressing the down arrow key you will come to the operation / setup level junction.

Entering Setup

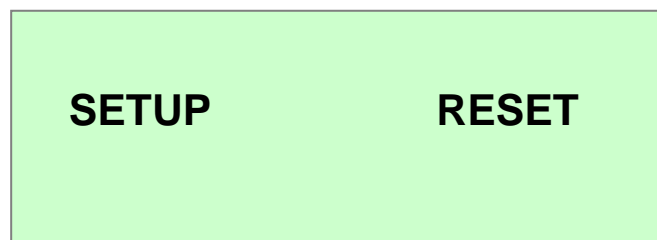

Enter the setup submenu by pressing the right arrow key. A cursor appears under the word **SETUP**. Confirm by pressing the enter key (ENTER). Or simply press two times the enter key!

For deactivating the setup level refer to *Exit Setup* later in this chapter.

If you mark the word *RESET* with the cursor and confirm with *RESET* then all parameters are set to their default values.

Remember that you leave with the ESC key without changing anything in the particular window.

Note



Access to the setup submenu can be locked and unlocked by applying respective commands via the serial interface communication port. The commands are described in section 5.5.

Note



By using the default settings you can ease the setup procedure. Refer to *Exit Setup* (last window of the setup level) of how to select either pressure or flow setup.

Once entered the setup submenu use the down/up arrow keys to step successively to the different windows.

Configuration of display 1 and display 2

DISPLAY1	CH1	CH2
DISPLAY2	FL2	SP2

In this first window of the setup submenu display #1 and display #2 of the operational level are being configured. Use the arrow keys to select and set the settings:

CH1,2	select one or both channel(s) to be displayed
VA1,2	display the signal output of channel 1 and/or channel 2
SP1,2	display setpoint of channel 1 and/or channel 2
EX1,2	external setpoint for channel 1 / channel 2
PR1,2	display as pressure (PR = Pressure)
FL1,2	display as flow (FL = Flow)

You can activate and deactivate display #2: Place the cursor between the word *DISPLAY2* and the following character, then make your choice with the up/down arrow keys.

Configuration of display 3 and display 4

DISPLAY3
DISPLAY4

Activation and configuration of display #3 is done the same way as described for display #1 and display #2.

In display #4 you can write any information using the serial interface (refer to chapter 5). The display itself however can be activated or deactivated only via front panel operation.

After completing setup you may have therefore up to three operational displays whose contents can be individually configured.

Setpoint

SP1	05.000	mbar
SP2	20.000	sccm

Here you can enter the setpoint for massflowcontrollers (MFC) as well as for in-line pressure controllers, e.g. MKS type 640. The example shows an MFC on channel 2 and a pressure controller being operated by channel 1.

The PR4000B-F takes automatically into account any corrections which may be necessary because of zero offset compensation.

The adjustable range and the engineering units are determined by the chosen range as shown next:

Range

RNG1	10.000	mbar
RNG2	50.000	sccm

Place the cursor by using the left/right arrow keys under the parameter to be edited. Edit range and engineering unit by using the up/down arrow key.

Also the position of the decimal point can be edited.

The following engineering units are available:

mbar – bar – mTorr – Torr – kTorr – Pa – kPa – mH₂O – cmH₂O – PSI – N/m² – sccm – slm – scm – scfh – scfm – mA – V - % - C – μbar.

All ranges may be set in a format between 99999 und 00000.

Gain and Offset

(extra windows for channel 1 and channel 2)

GAIN1	<u>0</u>1.0000
OFFS1	- 00043 mV

GAIN is a factor which adapts the range and the measurement signal for correct readout. A typical application is to use the gain factor as the gas correction factor with thermal mass flow meters or mass flow controllers.

Available range setting: 0.001 – 2.000.

Example for a MFC at channel 1, calibrated for 200 sccm full scale of nitrogen. The process gas used is carbon dioxide CO₂. The gas correction table in the user manual of the mass flow controller indicates a gas correction factor of 0.70 .

Range setting: RNG1 200.00 sccm

Gas correction factor setting: GAIN 00.7000

This finally results in a range of 0 – 140 sccm CO₂, which is displayed correctly by the PR4000B-F.

OFFS is the zero offset value of the respective input signal. Typically the zero offset is corrected by the auto zero cycle (refer to section *Control*) and the resulting value is shown here. It also possible to enter the respective value here which may be necessary in exceptional cases.

Range Turndown Offset

RTDOFFS1	-005 mV
RTDOFFS2	00<u>0</u> mV

The PR4000B-F allows the user to switch a Baratron 120 series in the range turndown mode automatically. This is described in detail in the section *Control*. The auto zero mode determines the zero offset value of both ranges to achieve highest accuracy.

It is of course also possible to enter the offset values for both ranges manually as described in the menu before.

Input Signal Range and Output Signal Range

(extra windows for channel 1 and channel 2)

IN1	10V	OUT1	5V
EI1	5V	EO1	5V

Each signal input and output can be set for a range between 1 V and 10 V in steps of 1 V. This allows the use of MFC's with 10 V full scale flow and/or 10 V setpoint signal or pressure transducers with for example 5 Volt full scale.

Select with the left/right arrow keys the respective parameter and make the setting using the up/down arrow keys.

IN1	Signal full scale of the transducer or controller connected to channel 1 (Pin 2, connector <i>CHANNEL 1</i>)
OUT1	Setpoint signal full scale for the MFC or pressure controller connected to channel 1 (Pin 8, connector <i>CHANNEL 1</i>)
EI1	External setpoint input for channel 1 (Pin 1, connector <i>EXTERN</i>)
EO1	Monitor signal output of channel 1 (Pin 3, connector <i>EXTERN</i>)

Respectively for channel 2 :

IN2	Signal full scale of the transducer or controller connected to channel 2 (Pin 2, connector <i>CHANNEL 2</i>)
OUT2	Setpoint signal full scale for the MFC or pressure controller connected to channel 2 (Pin 8, connector <i>CHANNEL 2</i>)
EI2	External setpoint input for channel 2 (Pin 2, connector <i>EXTERN</i>)
EO2	Monitor signal output of channel 2 (Pin 4, connector <i>EXTERN</i>)

Confirm all settings with the *ENTER* key before you leave the window.

Signalmode

(extra window for channel 1 and channel 2)

SIGMODE1	INDEP
SCL1	<u>10.000</u> mbar

SIGMODE:

For controllers the parameter *SIGMODE* determines the source of the setpoint which shall be applied to the respective channel. For meters this parameter determines to which value the setpoint output is set.

<i>INDEP</i>	(Independent) Setpoint is set either by the front panel settings or by remote host computer. Manual setpoint adjust can be done either in the setup submenu or in a window in the operational level (if the window is configured for displaying setpoint).
<i>OFF</i>	Setpoint output voltage is set to a fixed voltage of about $-0,5\text{ V}$. This ensures that the integrator of a controller connected to this channel does not wind up thus opening the control valve unintended. The digital output connector CHANNEL1 or CHANNEL2, pin 4 is held to LOW. This activates the input <i>Valve Close</i> of MFC's, forcing the control valve to be closed.
<i>METER</i>	Setpoint output voltage is set to zero volts. Valve override line via pin 4 of the respective channel connector is set to HIGH.
<i>RTD</i>	Range-Turndown (RTD) allows operation of a Baratron type 120. The digital output pin 4 of connector CHANNEL1 or CHANNEL2 is set to LOW when the signal of the type 120 is falls below 1 V. This enables the PR4000B-F to display also the lower pressure decades in full resolution. Refer to section <i>CONTROL</i> detailed instructions.
<i>SLAVE</i>	The setpoint of a slave channel is derived from the other channel's signal. This allows the control of gas mixing systems with a fixed flow ratio.
<i>EXTRN</i> (external setpoint)	The channel's setpoint is derived by an external analog voltage source, connected to connector <i>EXTERN</i> .

SCL (only *SLAVE* or *EXTRN*) :

The value of *SCL* (Scaler) determines the ratio of the setpoint which will be applied to the slave.

Example for two mass flow controllers:

Channel 1: MFC 500 sccm full scale, Mode *Independent*. This is the master channel!
 Channel 2: MFC 200 sccm full scale, Mode *Slave*.
 Scaler *SCL* set to 080.00 sccm.

When the master's flow readout ranges from 0 –500 sccm the setpoint applied to the slave ranges proportionally from 0 – 80 sccm ! The gas mixing ratio therefore is set to:

$$500 : 80 = 6,25 : 1$$

Example as before but for external setpoint mode *EXTRN*:

Channel 1: MFC 500 sccm full scale, Mode *EXTRN* (this makes channel 1 to be the „slave“ of the external setpoint source!

Scaler *SCL* set to 350.00 sccm.

This means that the external setpoint applied to channel 1 will be scaled down by a factor of

$$350 : 500 = 0,7.$$

Depending on configuration and operational mode it is possible to have the setpoint input(s) displayed. This however is possible only in the *INDEP* mode.

For optimum control performance it is advised not to set the scaler to values below 20 % off the MFC. It is possible but you should instead use MFC's with lower ranges.

Note

The setting of the scaler does not affect the independence mode *INDEP*!

Linearization

(extra window for channel 1 and channel 2)

LIN1	P0	S0	mbar
00.000	<>	00.000	

The PR4000B-F offers the possibility to correct known the non-linearity of each transducer connected to the instrument. This menu provides 11 correction points P0 – P10 for each channel. With the values S0 – S10 you can determine how many calibration points shall be used.

Example for a pressure transducer, 1 mbar full scale. The 6 point calibration data sheet lists the known deviation:

Cal. Point	Pressure (mbar)	Baratron Reading (mbar)
0	0,000	0,000
1	0,1051	0,1048
2	0,1996	0,2004
3...5
6	1,0137	1,0121

Then the settings for P and S for the correction point #2 would be:

LIN1	P2	S6	mbar
0.1996	<>	0.2004	

The sequence of the correction points must be strong monotone. Linearization is done by linear interpolation between two consecutive data points.

Trip Limits

The PR4000B-F provides three trip limit modes: *LIMIT*, *BAND* and *SLEEP*. The supervision modes *LIMIT* and *BAND* further provide a memory mode by selecting *MLIMIT* and *MBAND* respectively.

Limit-Mode:

(extra window for channel 1 and channel 2)

LIM	MODE1	LIMIT
DEAD	BAND1	1.5%

In the limit mode you can set two switchpoints and the hysteresis. In the window shown the hysteresis (*DEAD BAND*) is set to 1,5%.

UL1	030.00 mbar
LL1	015.00 mbar

The switchpoints shown are set to: *UL* (Upper Limit) = 30,00 mbar
LL (Lower Limit) = 15,00 mbar

It is also possible to set a switchpoint to a negative value: Set the cursor in front of the parameter and press the down key.

The switching mode of the relay RLY1 and RLY2 is configured in this menu:

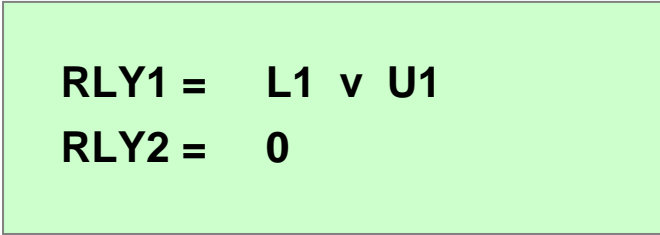

RLY1 = L1 v U1
RLY2 = 0

In the example shown relay RLY1 is activated (and simultaneously shown is it's status) when the lower limit 1 (here 15,00 mbar) was passed or (indicated by the logic symbol V) the upper limit U1 (here 30,00 mbar) was passed.

To both limits the selected value for the hysteresis must be added.

In the example shown relay RLY2 is set to an idle state.

Refer to the section *Relay Settings* at the end of this chapter to get detailed description and instructions of the numerous settings and logical criteria.

Temporary Criteria

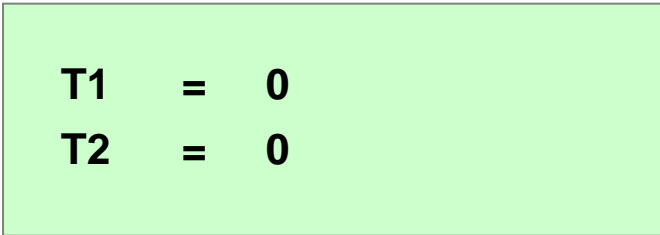

T1 = 0
T2 = 0

Transient events can also be combined with the relay operation.

For more instructions refer to the section *Relay Settings* at the end of this chapter.

Interface RS232

Selectable baud rates: 110 – 1200 – 2400 – 4800 – 9600 – 19200 – 38400 – 57600 –
76800 – 115000 Baud

BAUDRATE	<u>9</u>600 Bd
PARITY	ODD

Parities: Odd – Even – None

For more instructions refer to chapter 5 *INTERFACE*.

Interface RS485

ADRESS	--
IFACEMODE	--

In this menu the address and interface mode are selected (Only for units with RS485 interface)

For more instructions refer to chapter 5 *INTERFACE*.

Exit Setup

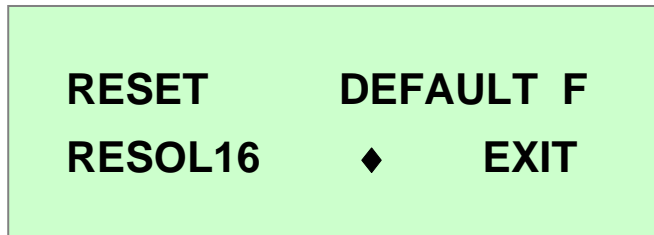

RESET All error messages will be reset.

DEFAULT F Setup menu will completely set to standard settings for MFC's and MFM

DEFAULT P Setup menu will completely set to standard settings for Baratron pressure transducers.

In appendix C you will find a complete table showing the default settings for both flow and pressure.

The letter F or P does not represent the status of the PR 4000 settings (It will be set to F after repower); it only selects the DEFAULT settings as listed in appendix C when using the DEFAULT function.

RESOL16 activated (indicated by a diamond shaped sign):

4,5 digit display format,
recommended for pressure measurement with Baratron pressure transducers.

De-activated (no diamond sign):

3,5 digit display format,
preferable for flow measurement and control with thermal flow devices.

EXIT Leaves the setup submenu. To enter again the setup section you must select *SETUP* again.

Note



Resolution and conversion rate are dependent of the display format. Refer to Appendix A, *Specifications*.

4.4. Control

For routine operation, e.g. flow readout and setpoint settings, after the setup has been finished there will be 1 to three windows, depending on the configuration chosen, plus two displays for control parameters and status information.

Display for measurement values and setpoints

Example for setting of display 1:

CH1	05.160 mbar
CH2	17.690 sccm

Example for display 2:

FL2	17.690 sccm
SP2	<u>20.000</u> sccm

The windows above show the format which would come up when following the examples described in the section *Setup*.

To ease operation the setpoints SP1 or SP2 can be set here. It is not necessary to enter the setup.

Messages:

OVERFLW

The measurement signal exceeds +11 V. As an example this would be the case when an absolute pressure transducer with a low full scale range, e.g. 1 mbar, is connected to this channel and its port is open to atmosphere.

UNDRFLW

The measurement signal exceeds -11 V.

Status Displays



RLY1, RLY2

A diamond sign indicates if the respective relay is activated.

RTD1, RTD2

A diamond sign indicates if the range turndown function is activated.

OK, EXXX

Error message appears here. Refer to appendix B for a list of error codes and their interpretation.

Example 1:

OK: no error detected

Example 2:

E002: Error! Can not perform autozeroing

Control Display

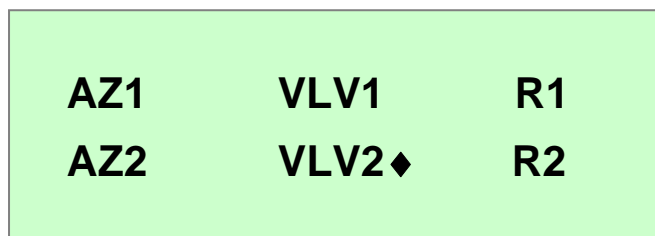

AZ1, AZ2

Zero adjustment (AutoZero) of channel 1 or channel 2 respectively. To initiate the autozero cycle first indicate the respective channel with the left/ right arrow key and then press the *ENTER* key. It is recommended to check that the readout will be set to zero (0 ± 1 Digit). Repeat the autozero cycle if necessary.

For correct zeroing please read the respective instructions for the transducers, meters or controllers in use, e.g. thermal stabilization, proper evacuating of absolute pressure transducers etc.

The PR4000B-F stores the detected offset of the transducer, meter or controller in use and corrects automatically the reading by this value. In case of MFC's or pressure controller the setpoint which is sent out will also be corrected automatically.

During the autozero cycle the display shows *ACTIVE* followed by a short report *DONE* if the procedure was completed successfully.

If the zero offset signal of the meter exceeds ± 250 mV the PR4000F will not perform the autozero process and display *FAIL*. If this is the case you should carefully check if all requirements for a correct zeroing are fulfilled and, if necessary, do a coarse zero adjustment at the meter or transducer.

The zero offset value is displayed in the setup menu in the window *OFFS*.

When zeroing the type 120 the zero offset values in both ranges are determined and compensated (provided that the range turndown function is activated). For more information refer to section *Operation with Baratron Type 120* later in this chapter.

VLV1, VLV2

Applies only to MFC's and pressure controllers. *VLV1, VLV2* are so called valve switches, that means that a setpoint voltage will only be applied to a pre-selected channel. Mark the respective channel with the left/right arrow keys until the cursor appears at the right side of *VLVX*. Then use either the up or the down key to generate a diamond sign and confirm with the *ENTER* key.

Any channel marked with a diamond can be switched on with the *ON* key. This allows to switch on or off channels individually or all channels simultaneously (Refer also to *Note* in section 4.6).

R1, R2

In this menu you can switch on or off the indicated relay, e.g. for test purposes.

Diamond sign activated: relay is activated (switched on)

Diamond sign not activated: relay is de-activated (switched off)

Note



The setpoint voltage will be applied only to channels which have been pre-selected with the valve switch *VLV1* or *VLV2*.

4.5. Operation with pressure transducers

If just pressure transducers Baratron series are used it is recommended to simplify the setup settings by using the default configuration for pressure *DEFAULT P*: All pressure readouts are set to mbar, all analog inputs and outputs are set to 10 V. See the table in appendix C for all default settings. Make sure anyway that the data of your pressure transducer confirm with the defaults, otherwise change the setup settings where needed.

With setup settings completed and zeroing done, in most cases no more is necessary to be done. You can immediately start measuring pressure using display 1, configured for PR1 and PR2.

Operation with Baratron Type 120

Range Turndown

This type pressure transducer has a recommended measurement range of five decades, that means the lowest pressure displayed should be $1E-5$ of full scale. The readout of the PR4000F however will display only four decades thus the lowest pressure displayed would be $1E-4$ of full scale. The type 120 provides a digital input (Range Turndown) which allows, when pulled to low signal, to increase the output voltage by a factor of ten. The PR4000B-F can support this function thus enabling the measurement in the range below 10% of the transducer's full scale range with full display resolution.

Example for a type 120, 1 mbar full scale

Range	Signal Output
0 1 mbar, Range Turndown not active	0 10 V; 1 mV equals $1 \cdot 10^{-4}$ mbar
0 0,1 mbar, Range Turndown active	0 10 V; 1 mV equals $1 \cdot 10^{-5}$ mbar

As explained before the PR4000B-F will display the complete pressure measurement range of the type 120, with no restriction of the specified resolution, provided the *RTD* mode has been selected. To do this the unit will switch at 10 % of full scale automatically the range down. Simultaneously also the display format switches, so the last digit represents $1E-5$ of full scale. The hysteresis at the switch point is 0,5% of full scale.

For the example given above this means (hysteresis disregarded):

Pressure	Readout	RTD
0 0,1 mbar	0,00000 0,09999 mbar	active
0,1 1 mbar	0,1000 1,0000 mbar	Not active

When the autozero cycle is triggered the zero offset of both ranges will be separately determined and corrected. The zero offset value in any range should not exceed 50 mV. If this is the case, then carefully check if all requirements for a correct zeroing are fulfilled and, if necessary, do a coarse zero adjustment directly at the type 120 pressure transducer.

Check after zeroing that the readout displays 0 ± 1 Digit. Repeat the autozero procedure if necessary.

4.6. Operation with mass flow controllers (MFC)

For the use with mass flow controllers (MFC) only, it is recommended to simplify the setup settings by using the default configuration for flow *DEFAULT F*: All flow readouts are set to sccm, all analog inputs and outputs are set to 5 V. Most (if not all) parameters to be edited are set to standard values but should be checked anyway. See the table in appendix C for all default settings. Change the setup settings where needed.

Always check the correct setting of parameter *GAIN* to consider the right gas correction factor!

As readouts one will preferably use display 1 and display 2 for displaying both flow and setpoint. Example: use display 1 for flow readout and display 2 to enter and display the setpoints.

The setpoints can be entered in either the setup menu or in the respectively configured display.

Note: To activate the setpoint output press the *ON* key. The activation is indicated by the LED *SETPOINT*. Press the key *OFF* to switch off the setpoint output. If no LED *SETPOINT* is activated then none of both channels was pre-selected, that means the valve switch is off. Refer to the section *Control Display, VLV1, VLV2*.

Note



The setpoint voltage will be applied only to channels which have been pre-selected with the valve switch *VLV1* or *VLV2*.

Beside the thermal mass flow controllers also pressure based MFC's by MKS Instruments type 1150, 1151 and 1152 can be combined to the PR4000B-F.

Control Modes with Mass Flow Controllers:

- a. *INDEP* Use this mode if the MFC shall be operated independently from the other channel and setpoints are entered manually through the front panel keys.
- b. *EXTRN* In this mode the MFC shall be operated independently too but the setpoint comes from an external signal source.
The range of the external setpoint voltage must be defined in the setup section for *E11* or *E12* respectively.
The setting of the scaler *SCL* determines the ratio of the external setpoint to be applied to the respective channel.

Example for an MFC, control range 0 - 100 sccm, external setpoint voltage range 0 – 5 VDC. At 5 VDC external setpoint voltage a flow rate of 40 sccm shall be generated.
Therefore you must set the scaler *SCL*: 40 sccm !

The external setpoint signal however could be derived from the flow signal of another PR4000. This allows for example to configurate several channels to a gas mixing system.

The value of the external voltage can be displayed: Use the *EX* mode in the display configuration (ref. to section *Setup*).

- c. *SLAVE* If one channel is configured as a slave then the other channel of the unit becomes automatically the master of this slave. The slave's setpoint is derived from the actual signal of the master. This enables configurations of gas mixing systems with fixed ratio, e.g. for supplying gas burners, deposition purposes etc.
- An example is given in the *SETUP* section.
- Combinations of these modes are possible.

4.7. Operation with flow meters

For the use with mass flow meters it is recommended to simplify the setup settings by using the default configuration for flow *DEFAULT F*: All flow readouts will be set to sccm, all analog inputs and outputs set to 5 V. Most (if not all) parameters to be edited are set to standard values but should be checked anyway. See the table in appendix C for all default settings. Change the setup settings where needed.

Always check the correct setting of parameter *GAIN* to consider the right gas correction factor!

Because flow meters do not require setpoint signals one could use only display 1 for both flow readouts FL1 and FL2.

4.8. Operation with pressure controllers

This operation mode mainly affects in line pressure controllers from von MKS Instruments, e.g. the types 640, 641 or 649. In general the above given instructions for mass flow controllers apply also here. In some cases the pressure controllers are configured for different voltage input/output signals, therefore check carefully the conformity of both the controller and the PR4000B-F.

Note



The setpoint voltage will be applied only to channels which have been pre-selected with the valve switch *VLV1* or *VLV2*.

4.9. Limit switches and relays

The two relays on the hardware may be assigned flexible to the channels and different signal sources. The logic of the limit switches is configurable and also is the hysteresis (i.e. dead band). A switch delay is not available.

The PR4000B-F provides 5 modes of trip limit operation:

SLEEP

In this mode the trip limits are not active.

LIMIT

In LIMIT mode the signal L is triggered if the actual input is below LL and the signal U is triggered if the actual input is above UL.

BAND

In BAND mode the signal L is triggered if actual input is below set point minus LL. And the signal U is triggered if actual input is above set point plus UL.

MLIMIT

Same as Limit mode but including memory capability. The memory can be reset with *RESET*.

MBAND

Same as Band mode but including memory capability. The memory can be reset with *RESET*.

4.10. Relay Settings

Configuration of relay control is done in the aforementioned menu *Limit-Mode* in the setup section. By the use of logical formulas almost each combination of different criteria for activating (or de-activating) the relays can be realized. This allows flexible adoption of both relays to many demands.

The PR4000B-F supports the following criteria, numbers indicate the respective channel:

- R1 / R2 -> Menu parameter for manual relay control (RLY) is switched on.
- L1 / L2 -> Signal is below the lower limit value
- U1 / U2 -> Signal is above the higher limit value
- E1 / E2 -> External digital Input (relay connector) is active
- V1 / V2 -> Valve switch (sequential setpoint switch) of the channel is on
- D1 / D2 -> RTD line in the range turn down mode is active
- T1 - T4 -> Results of 4 temporary formulas to increase the flexibility of combinations
- 0 e.g. 1 -> constant values for manual input of criteria

These criteria are combined by logical formulas, e.g. AND, OR etc. operations. An AND operation for example means that criteria A and B must be fulfilled to switch the relay.

The PR4000B-F supports the following operations, the symbols in parenthesis show the characters as they appear on the display:

- AND (^) Criteria A and B must be fulfilled
- OR (v) Criteria A or Criteria B or both must be fulfilled
- ESCLUSIVE OR (#) either Criteria A or Criteria B must be fulfilled (but not both)
- NOT (¬) Criteria must not be fulfilled (Negation).

Here are two examples for the use of logic formulas for the relay status:

$$\begin{aligned} L1 \vee \neg U2 &= L1 \text{ OR NOT } U2 \\ R1 \wedge L1 \wedge E1 &= R1 \text{ AND } L1 \text{ AND } E1 \end{aligned}$$

The PR4000B-F applies these formulas to the relays RLY1 and RLY2. Use the cursor which allows the following settings dependent from his position (RLY = R1):

- Position under " = " -> Selection of numbers of criteria
- Position before or after criteria -> Choice of operation
- Position under a criteria -> Choice of criteria or of a constant value

Examples:

- RLY1 = $L1 \vee \neg U2$ Relay 1 is activated when the signal is below lower limit of channel 1 or high limit of channel 2 is not exceeded
- RLY2 = $R1 \wedge L1 \wedge E1$ Relay 2 is active when R1 and E1 are activated and signal is below lower limit of channel 1

Chapter 5: Interface

5.1. General

The PR4000B-F offers two serial interfaces, a RS232 and a RS485. The RS232 is a connection between two devices (Host and PR4000). The RS485 connects the host to up to 30 PR4000, what makes an address code for each command necessary.

The synchronization between host and PR4000 is maintained by a strict command / reply cycle. You may only send the next command, if there was a reply received completely.

The parser brings an error on wrong commands, but not on ambiguous commands. In this case it processes the closest idea of the information received. Terminate command only with <CR>, never with <CR><LF>.

5.2. Command syntax

The command syntax is defined as follows, were tokens in brackets are optional and token divided by a separator are alternatives. There are no blanks between command elements needed. Yellow characters are constant, gray characters represent placeholders for command values.

```
[@aa][?!]<cmdc/cmd>[p1[,p2[,p3]]]<CR>
```

@aa	address with two digit address flag @. This element is only used with the RS485 interface. Delete this element when using the RS 232 port. E.g. @12 identifies device with address 12.
?	request prefix causes the device to return the actual value of the parameter identified by cmdc or cmd. E.g. ?DG asks for the actual dialog
!	default prefix causes the device to set the value of the parameter identified by cmdc or cmd to default. E.g. !OF1 sets for the offset to zero.
cmd cmdc	command or cahnnel specific command, identifies device parameter or function. cmdc is with cahnnel specification 1 or 2. E.g. OF1,0.012 sets for the offset to 0.012.
p1 p2 p3	parameter for the function or command. E.g. OF1,0.012 0.012. is parameter p1
<CR>	command terminator "carriage return" (13).
,	token separator

5.3. Reply syntax

The reply syntax is defined as follows, where token in brackets are optional. There are no blanks between command elements needed. Yellow characters are constant, gray characters represent placeholders for command values.

```
[r1[,r2[,r3]]<CR>
```

r1 r2 r3	reply values of command.
<CR>	reply terminator "carriage return" (13).
,	value separator

5.4. Error reply syntax

```
#Ennn<CR>
```

nnn	error codes: # error escape flag #E010 syntax error #E020 FAIL of a command execution, e.g. OF command
<CR>	terminator "carriage return" (13).

5.5 Commands

Sample Command

command		<u>description</u>
<u>reply</u>		
sample 1	reply 1	sample description 1
sample 2	reply 2	sample description 2

Display Text (DT)

DT[,text]		<u>displays text in the display 4</u>
[text]		text: 32 byte string, which will be written to display 4.
DT,HELLO		display text "HELLO"
?DT	"HELLO"	return displayed text
!DT		blanks out display

Request Key (KY)

KY		<u>request most recently pressed key</u>
key[,number]		OFF = 00007, ON = 00008, ESC = 00009, ENTER = 00010, RIGHT = 00011, LEFT = 00012, UP = 00013, DOWN = 00014, No Key = 00255 Number: 0 ... n
KY	00013	return key code which was pressed most recently. If no key was pressed since last command then 00225,00000 is returned
?KY	00014,00001	return key code and number of keys, which were not polled since last command

Dialog (DG)

DG[,dialog]		set display to a specific dialog
[dialog]		dialog: dialog index. See also Appendix D Dialog Reference
DG,2		set display do dialog #2
?DG	00004	return actually displayed dialog

ID String (ID)

ID		retrieve ID string
PR42vvrsssss		format: vv = version rr = release sssss = serial number
ID	PR42012900000	returns ID string
?ID	PR42012900000	returns ID string

Remote Mode (RT)

RT[,enable]		set to remote operation
[enable]		enable: OFF, ON
RT,ON		switch PR4000 to remote mode
?RT	ON	ask for remote mode
RT,OFF		switch PR4000 to local mode

Access Channel (AC)

ACc[,setpoint[,vlv]]		access channel
actvalue[,vlv]		setpoint, actvalue: -5% .. 110% of FS (formatted in selected range) vlv: OFF, ON
AC1,100.00	-010.00	set setpoint of channel 1 and retrieve actual value
AC2,100.00,ON	099.99	set setpoint of channel 2, enable channel valve and retrieve actual value.
?AC1	099.99,ON	retrieve actual value

Actual Value (AV)

AVc[,setpoint]		<u>get actual value</u>
actvalue		setpoint, actvalue: -5% .. 110% of FS (formatted in selected range)
AV1	099.99	retrieve actual value
AV1,50.0	099.99	retrieve actual value and set setpoint

Setpoint (SP)

SPc[,setpoint]		<u>set setpoint</u>
[setpoint]		setpoint: -5% .. 110% of FS (formatted in selected range)
SP1,50.0		set setpoint
?SP1	050.00	retrieve setpoint

External Input (EX)

EXc		<u>access of EXTERN channels</u>
extinput		extinput: -5% .. 110% of FS (formatted in selected range)
EX1	000.00	retrieve external input

Status (ST)

ST		request of hex status word
hexsts		hexsts bits: 0 = comerr; 1 = underrange AIN0; 2 = overrange AIN0; 3 = underrange AIN1; 4 = overrange AIN1; 5 = relay0; 6 = relay1; 7 = parameter changed by user
ST	00128	retrieve status

Valves (VL)

VLc[,enable]		<u>set channel specific valve status</u>
[enable]		enable: OFF, ON
VL1,ON		set valve of channel 1
VL0, OFF		disable valve of both channels
?VL1	ON	retrieve valve status of channel 1

Relays (RL)

RLc[,enable]		<u>set manual setting of relay</u>
[enable]		enable: OFF, ON
RL1,ON		set relay 1
?RL1	ON	retrieve relay 1 status

Displays (DP)

DPd,(line,tag,chn enable)		<u>setup configurable displays</u>
(tag,chn) OFF		line: 1, 2 tag: 0=SP, 1=VA, 2=CH, 3=FL, 4=PR, 5=EX chn = 1, 2 enable: OFF, ON
DP1,1,3,1		sets display 1, line 1 to FL of channel 1
?DP1,1	3,1	retrieve setting of display 1
DP2,OFF		switch display 2 off

Display 4 (DP4)

DP4[,enable]		<u>setup configurable display 4</u>
[enable]		enable: OFF, ON
DP4,ON		switch display 4 on

Range (RG)

RGc[,range,unit]	<u>setup range and engineering units</u>		
[range,unit]	range : 5 digits		
	unit:	ubar = 0	mbar = 1 bar = 2
		mTor = 3	Torr = 4 KTor = 5
		Pa = 6	kPa = 7 mH ₂ O = 8
		cH ₂ O = 9	PSI = 10 N/qm = 11
		SCCM = 12	SLM = 13 SCM = 14
		SCFH = 15	SCFM = 16 mA = 17
		V = 18	% = 19 C = 20
RG1,5,0,12		set range of channel 1 to 50 SCCM	
?RG1	5.0000,00012	retrieve range and unit	

Gain (GN)

GNc[,gain]	<u>setup gain</u>	
[gain]	gain: 0,001 .. 2.000	
GN1,1.3		set gain of channel 1
?GN1	01.300	retrieve gain

Offset (OF)

OFc[,offset]	<u>setup offset</u>	
[offset]	offset: -250 .. +250	
OF1,30		set offset of channel 1
?OF1	00030	retrieve offset

RTD Offset (RO)

ROc[,offset]	<u>setup RTD offset</u>	
[offset]	offset: -250 .. +250	
RO1,3		set offset of channel 1
?RO1	00003	retrieve offset

Autozero (AZ)

AZc		<u>trigger autozero</u>
offset		offset: -250 .. +250
AZ1	00003	perform autozero function of channel 1.

Input Range (IN)

INc[,phyrange]		<u>setup of physical input range</u>
[phyrange]		phyrange: 1 .. 10
IN1,10		set input range of channel 1 to 10 V
?IN1	00010	retrieve input range

Output Range (OT)

OTc[,phyrange]		<u>setup of physical output range</u>
[phyrange]		phyrange: 1 .. 10
OT1,10		set output range of channel 1 to 10 V
?OT1	00010	retrieve output range

External Input Range (EI)

EIc[,phyrange]		<u>setup of physical input range</u>
[phyrange]		phyrange: 1 .. 10
EI1,10		set external input range to 10 V
?EI1	00010	retrieve external input range

External Output Range (EO)

OTc[,phyrange]		<u>setup of physical output range</u>
[phyrange]		phyrange: 1 .. 10
OT1,10		set external output range to 10 V
?OT1	00010	retrieve external output range

Signal Mode (SM)

SMc[,smode]	<u>setup of signal mode</u>	
[smode]	smode: 0 = METER, 1 = OFF, 2 = INDEP, 3 = EXTRN, 4 = SLAVE, 5 = RTD,	
SM1,2		set signal mode to independent
?SM1	00002	retrieve signal mode

Scale (SC)

SCc[,scale]	<u>setup of scale</u>	
[scale]	scale: -5% .. 110% of FS (formatted in selected range)	
SC1,30.0		set scale
?SC1	30.000	retrieve scale

Linearization (LN, LS)

LNc[,point,x,y]	<u>setup of linearization table</u>	
[x,y]	point: 0 .. 10 x, y: -5% .. 100% of FS (formatted in selected range)	
LN1,2,2.1,2.2		set point of lin. table
?LN1,2	02.000, 02.000	retrieve point in lin. table

LSc[,size]	<u>setup of table size</u>	
[size]	size: 0 ..10	
LS1,2		set table size
?LS1	00002	retrieve table size

Limit Mode (LM)

LMc[,lmode]	<u>setup limit mode</u>	
[lmode]	lmode: 0 = SLEEP, 1 = LIMIT, 2 = BAND, 3 = MLIMIT, 4 = MBAND	
LM1,1		set limit mode
?LM1	00001	retrieve limit mode

Dead Band (DB)

DBc[,deadband]		<u>setup of dead band(HY is an alias)</u>
[deadband]		deadband: 0.0% .. 9.9% of FS
DB1,1.2		set dead band
?DB1	01.200	retrieve dead band

Upper Limit (UL)

ULc[,upperlimit]		<u>setup of upper limit</u>
[upperlimit]		upper limit: -5% .. 110% of FS (formatted in selected range)
UL1,80.0		set upper limit
?UL1	80.000	retrieve upper limit

Lower Limit (LL)

LLc[,lowerlimit]		<u>setup of lower limit</u>
[lowerlimit]		lower limit: -5% .. 110% of FS (formatted in selected range)
LL1,20.0		set lower limit
?LL1	20.000	retrieve lower limit

Formula Relay (FR)

FRr[,<u>neg</u>src [<u>op</u><u>neg</u>src] [<u>op</u><u>neg</u>src]]		<u>setup of relay source</u>
[<u>neg</u>src [<u>op</u><u>neg</u>src] [<u>op</u><u>neg</u>src]]		r: Number of formula (1, 2). neg: Sign for negation is ! src: R1,R2,L1,L2,U1,U2,E1,E2,V1,V2, D1,D2,T1,T2,T3,T4,1,0 op: Operator (+ is OR, * is AND, x is XOR)
FR1,!R1+!T4+D1		set formula
?FR1	!R1+!T4+ D1	retrieve actual formula

Formula Temporary (FT)

FTt,[neg]src [op[neg]src] [op[neg]src]]		setup of temporary formula
[[neg]src [op[neg]src] [op[neg]src]]		t: Number of formula (1, 4) The rest is the same except that the four sources T1,T2,T3,T4 are not available.
FT1,IR1+!T4+D1		set formula
?FT1	IR1+!T4+ D1	retrieve actual formula

Parity (PY)

PY[,parity]		setup of parity
[parity]		parity: 0=NONE, 1=EVEN, 2=ODD
PY,2		set parity
?PY	00002	retrieve parity

Baudrate (BD)

BD[,baudrate]		setup of baudrate
[baudrate]		baudrate: 0 = 110, 1 = 1200, 2 = 2400, 3 = 4800, 4 = 9600, 5 = 19k2, 6 = 38k4, 7 = 57k6, 8 = 76k8, 9 = 110k
BD,4		set baudrate
?BD	00004	retrieve baudrate

Address (AD)

AD[,address]		setup of address
[address]		address: 0 .. 31
AD,4		set address
?AD	00004	retrieve address

Interface Mode (IM)

IM[,ifacemode]		setup of interfacemode
[ifacemode]		this command is not used at the moment
IM,4		set interface mode
?IM	00004	retriev interface mode

Resolution (RS)

RS[,enable]		<u>setup of 16 bit resolution</u>
[enable]		enable: OFF, ON
RS,ON		set resolution to 16 bit
?RS	ON	retrieve resolution

Reset Status (RE)

RE		<u>reset status</u>
RE		reset status

Default (DF)

DF,dmode		<u>reset to default values (Pres Flow)</u>
		dmode: P=pressure, F=flow
DF,P		set pressure default

Unlock (#0)

#0		unlock setup
----	--	--------------

Lock (#1)

#1		lock setup, access possible
----	--	-----------------------------

Tweak Control (\$0, \$1, ?\$)

\$0		switch off Tweak Control, e.g. for pressure controller type 640
\$1		switch on Tweak Control
?\$		test Tweak Control status
?\$	0	correct for pressure controller 640

Appendix A: Specifications

Number of channels	2 inputs for flow or pressure signals 2 inputs for external setpoints 2 outputs for setpoints 2 outputs for signal monitoring	
Accuracy	0,01% ± 1 Digit	
Temperature coefficient	Input:	0,1 mV / K (Ra < 1 Ω)
	Output:	0,075 mV / K
Display format and resolution	Two line LCD, 16 places per line , configurable: 4-digits: 0000 – 9999 (12 bit resolution) 5-digits: 00000 - 99999 (16 bit resolution)	
Conversion rate Mode:	EXTERN	<u>not</u> EXTERN
	Rate:	5 Hz at 16 bit 20 Hz at 12 bit
Signal input range (all)	±11 V, to be scaled in steps of 1 V	
Signal output range (all)	±11 V, to be scaled in steps of 1 V	
Relays	2 Relays, SPDT; nominal switching capacity (resistive load): 1A 30VDC, 0.5A 25VAC eff. ; can be combined with any channel	
Interface	Standard:	RS232
	Option:	RS485
Power output	Standard:	±15 V; 1,5 A
	Option:	24 V; 1 A
Input power	85 - 265 V; 47 - 63 Hz	
Operation temperature	15 – 40 °C	
CE	yes (ref. to section 2.3 <i>Cables</i>)	
RoHS	yes	
Housing	½ x 19" Rack Mounting or top on table use	
Weight:	2,4 kg	

This page left blank.

Appendix B: Error Messages

Code	Problem
E 001	Communication Error
E 002	ADC Overflow or Underflow
E 003	Range Error, Setpoint < 0 or out of Range
W 001	Offset > 250 mV

This page left blank.

Appendix C: Default – Configuration

Parameter	Default Flow	Default Pressure
DISPLAY1, 2	FL1, SP1; FL2, SP2	PR1, PR2; off
DISPLAY3, 4	off, off	off, off
SP1, SP2	100%, 100%	0%, 0%
RNG1, RNG2	100SCCM, 100SCCM	10mbar, 10mbar
GAIN1, OFFS1	1.0, 0mV	1.0, 0mV
GAIN2, OFFS2	1.0, 0mV	1.0, 0mV
RTDOFFS1, RTDOFFS2	0mV	0mV
IN1, OUT1, EI1, EO1	5V, 5V	10V, 10V
IN2, OUT2, EI2, EO2	5V, 5V	10V, 10V
SIGMODE1, SCL1	INDEP, 100%	METER, 0%
SIGMODE2, SCL2	INDEP, 100%	METER, 0%
LIN1	1:1; zero points	1:1; zero points
LIN2	1:1; zero points	1:1; zero points
LIM MODE1, DEAD BAND1	SLEEP, 0.0%	SLEEP, 0.0%
UL1, LL1	20%, 80%	20%, 80%
LIM MODE2, DEAD BAND2	SLEEP, 0.0%	SLEEP, 0.0%
UL2, LL2	20%, 80%	20%, 80%
RLY1, RLY2	0, 0	0, 0
T1, T2	0, 0	0, 0
T3, T4	0, 0	0, 0
BAUDRATE, PARITY	9600, ODD	9600, ODD
ADDRESS, IFACEMODE	0, 0	0, 0
RESOL16	no	yes

This page left blank.

Appendix D: Dialog Reference

Index	Dialog	Comment
0	tgc \$display tgc \$display	configurable display 0
1	tgc \$display tgc \$display	configurable display 1
2	tgc \$display tgc \$display	configurable display 2
3	XXXXXXXXXXXXXXXXXX XXXXXXXXXXXXXXXXXX	user display
4	RLY1b RTD1b err RLY2b RTD2b cmd	status display for relays, RTD, system errors and display recent interface command, ack. with ENTER
5	AZ1 VLV1b R1b AZ2 VLV2b R2b	autozero trigger and switches for valves and relays.
6	SETUP RESET V01.28 19991001	enter setup mode, reset status version and generation date (__DATE__)
7	DISPLAY1 tgc tgc DISPLAY2 tgc tgc	setup of display 1, 2; if both tags are off the display is not visible (DISPLAY2 may be switched off)
8	DISPLAY3 tgc tgc DISPLAY4 b	setup of display 3, 4; (DISPLAY3&4 may be switched off)
9	SP1 sd.ddd unit SP2 sd.ddd unit	setpoint setup
10	RNG1 d.ddd unit RNG2 d.ddd unit	range setup (last digit may be suppressed for 3.5 digit display)
11	GAIN1 sddd.ddd OFFS1 sddd mV	gain (7 digits), offset chn1. (0.001 < gain < 2.000); (-250mV < offset < 250mV)
12	GAIN2 sddd.ddd OFFS2 sddd mV	gain (7 digits), offset chn1. (0.001 < gain < 2.000); (-250mV < offset < 250mV)
13	RTDOFFS1 sddd mV RTDOFFS2 sddd mV	RTD offset
14	IN1 er OUT1 er EI1 er EO1 er	full scale I/O ranges chn1.
15	IN2 er OUT2 er EI2 er EO2 er	full scale I/O ranges chn2.

to be continued on next page

(continued)

Index	Dialog	Comment
16	SIGMODE1 <u>s</u> mode SC1 <u>sd</u> . <u>dddd</u> unit	signal processing modes SC is for scaling of the source
17	SIGMODE2 <u>s</u> mode SC2 <u>sd</u> . <u>dddd</u> unit	signal processing modes SC is for scaling of the source
18	LIN1 <u>pt</u> <u>ln</u> unit <u>sd</u> . <u>dddd</u> <> <u>sd</u> . <u>dddd</u>	linearization table chn1: 11 points and a length spec.
19	LIN2 <u>pt</u> <u>ln</u> unit <u>sd</u> . <u>dddd</u> <> <u>sd</u> . <u>dddd</u>	linearization table chn1: 11 points and a length spec.
20	LIM MODE1 <u>l</u> mode DEAD BAND 1 <u>d</u> . <u>d</u> %	limit mode: SLEEP, LIMIT, BAND, MLIMIT, MBAND hysterisis setup
21	UL1 <u>sd</u> . <u>dddd</u> unit LL1 <u>sd</u> . <u>dddd</u> unit	upper limit definition lower limit definition
22	LIM MODE2 <u>l</u> mode DEAD BAND 2 <u>d</u> . <u>d</u> %	limit mode: SLEEP, LIMIT, BAND, MLIMIT, MBAND hysterisis setup
23	UL2 <u>sd</u> . <u>dddd</u> unit LL2 <u>sd</u> . <u>dddd</u> unit	upper limit definition lower limit definition
24	RLY1= <u>\$formula</u> RLY2= <u>\$formula</u>	relay formulas
25	T1= <u>\$formula</u> T2= <u>\$formula</u>	temporary formulas
26	T3= <u>\$formula</u> T4= <u>\$formula</u>	temporary formulas
27	PARITY <u>prty</u> BAUDRATE <u>baud</u>	interface setup 1: parity & baudrate
28	ADDRESS <u>aa</u> IFACEMODE <u>dd</u>	interface setup 2: adress and interface mode; if (aa>0) then bus mode
29	<u>RESET</u> <u>DEFAULT</u> <u>d</u> <u>RESOL16</u> <u>b</u> <u>EXIT</u>	reset to default, reset status, exit setup, setup of 12/16 Bit resolution

MKS Worldwide Calibration & Service Centers

UNITED STATES

MKS Instruments, Inc.
Corporate Service Center
90 Industrial Way
Wilmington, MA 01887-4610
Tel (978) 284-4000
Fax (978) 284-4303

MKS Instruments, Inc.
HPS Division,
Vacuum Components,
Valves & Gauging
5330 Sterling Drive
Boulder, CO 80301
Tel (303) 449-9861
Fax (303) 449-2003

CANADA

MKS Instruments, Canada Ltd.
30 Concourse Gate
Nepean, Ontario, Canada K2E 7V7
(613) 723-3386
Tel (800) 267-3551 (CAN only)
Fax (613) 723-9160

FRANCE

MKS Instruments, France s.a.
43, Rue du Commandant Rolland
B.P. 41
F-93352 Le Bourget, Cedex,
France
Tel 33(1)48.35.39.39
Telex 233817 F
Fax 33(1)48.35.32.52

DENMARK

MKS Denmark ApS
Ndr. Strandvej 119G
DK-3150 Hellebæk
Tel 45-44 92 92 99
Fax 45-44 92 94 99
Email: mksdenmark@mksinst.com

TAIWAN

MKS Instruments, Taiwan
10F, No.93, Shoei-Yuan Street
Hsinchu City 300
Taiwan, R.O.C.
Tel 886-3-575 3040
Fax 886-3-575 3048

GERMANY/BENELUX

MKS Instruments,
Deutschland GmbH
Schatzbogen 43
D-81829 München
Tel 49-89-420008-0
Fax 49-89-42-41-06
Email: mks-germany@mksinst.com

ITALY

G. Gambetti Kenologia Srl.
Via A. Volta No. 2
20082 Binasco (MI), Italy
Tel 39-2-90093082
Fax 39-2-905.2778

JAPAN

MKS Japan, Inc.
Harmonize Building
5-17-13, Narita-Higashi
Suginami-Ku, Tokyo 166, Japan
Tel 81-3-3398-8219
Fax 81-3-3398-8984

KOREA

MKS Korea Co., Ltd.
1st Floor DK Plaza-I
375-1 Geumgok-dong
Bundang-gu, Seongnam Kyonggi-do
Korea 463-805
Tel 82-31-717-9244
Fax 82-31-714-9244

UNITED KINGDOM

MKS Instruments, U.K. Ltd.
1 Anchorage Court
Caspian Road
Altrincham, Cheshire
WA14 5HH, England
Tel 44-161-929-5500
Fax 44-161-929-5511

SINGAPUR

MKS Instruments, Inc.
BLK 4010 Techplace I
#01-08/09 Ang Mo Kio Avenue 10
Singapore 569623
Tel (65) 6451 1062
Fax (65) 6451 0172