

**Digital Mass Flow Controller
Type 1579A/B**
and
**Digital Mass Flow Meter
579A/B**

- Instruction Manual -

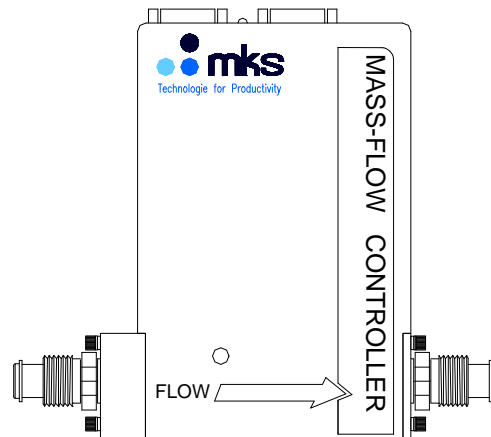

Copyright © 2009 by MKS Instruments Deutschland GmbH.

All rights reserved. No part of this work may be reproduced or transmitted in any form or by any means, electronic or mechanical, including photocopying and recording, or by any information storage or retrieval system, except as may be expressly permitted in writing by MKS Instruments.

Printed in the Federal Republic of Germany

Mass-Flo[®] is a registered trademark of MKS Instruments, Inc., Andover, MA

Swagelok[®], VCR[®], and VCO[®] are registered trademarks of Swagelok Marketing Company, Solon, OH

Cajon[®], VCR[®], and VCO[®] are registered trademarks of Cajon Company, Macedonia, OH

Kalrez[®] and Viton[®] are registered trademarks of DuPont Dow Elastomers Inc., Wilmington, DE

Teflon[®] is a registered trademark of E. I. DuPont de Nemours and Co. Inc., Wilmington, DE

Kel-F[®] is a registered trademark of 3M, Minneapolis, MN

NUPRO[®] is a registered trademark of Crawford Fitting Company, Solon, OH

Table of Contents

Safety Information	9
Symbols Used in This Instruction Manual.....	9
Safety Procedures and Precautions	10
Chapter 1: General Information.....	13
Introduction	13
Overview of Versions	13
Power Supply and Readout Units.....	14
Profibus Version.....	14
CE and EMC Requirements.....	14
Instruction Manual.....	15
Contents.....	15
Conventions	15
Designations and Names.....	15
Chapter 2: Shipment	17
General.....	17
Unpacking.....	17
Unpacking Checklist.....	17
Analog Units.....	17
Profibus Units.....	18
Label	19
Clean Room Packaging.....	19
Chapter 3: Connectors and Control Elements	21
Analog Units.....	21
Potentiometer ZERO.....	22
AUTOZERO	22
RESET Switch	22
Connector SETUP	22
Electrical Connector	23
1579A/B / 579A/B, Analog Unit.....	23
Profibus Units.....	24
Potentiometer ZERO.....	25
AUTOZERO	25
RESET Switch	25
Address and Mode switch A/B.....	25
Status LED STS.....	25

Electrical Connectors	26
1579A/B / 579A/B, Profibus Units, Connector ANALOG	26
1579A/B / 579A/B, Profibus Units, Connector PROFIBUS.....	27
Chapter 4: Operation	29
General Requirements	29
Environmental	29
Location and Orientation	30
Leak Integrity.....	30
Pressure Drop Test.....	30
Dimensions.....	31
Outline Dimensions	31
Mounting Holes	32
Mounting Plate	33
Electrical Connections and Cables	33
Cables and Controllers by MKS.....	33
Power Supply / Readout Units of other Manufacturers	34
Non MKS Cables.....	34
Finishing the Installation.....	34
Chapter 5: Operation (Analog Units)	35
Start Up the Mass Flow Controller/Meter	35
Zero Adjust	36
Override the Control Valve	37
Priority of Commands.....	37
Chapter 6: Operation (Profibus Units)	39
Functions	39
Overview	39
Valve Override	40
Auto Zero	40
Alarm Limits	40
Temperature Measurement	40
Valve Drive Level	40
User Span / Gas Correction.....	41
User Zero	41
Filter	41
Gas Tables.....	41
Soft Start Rate.....	41

Start Up the Mass Flow Controller	42
Zeroing the Flow Controller.....	43
Status LED STS	44
Address and Mode Switch A/B	44
Switch Assignment.....	44
Mode B.....	44
Setting an Address.....	45
Mode A.....	45
Zero Modes.....	45
PROFIBUS Protocol.....	46
Data Interface.....	46
Send Data	47
Small Receive Data	48
Full Receive Data.....	49
Small Setup.....	50
Full Setup.....	51
Small Diagnostics	53
Full Diagnostics.....	54
Calibration Table.....	56
PROFIBUS Setup	57
GSD Files Usage	57
Chapter 7: Theory of Operation	59
Technique of Measurement and Control, Electronics.....	59
Flow Path	59
Measurement Technique	59
Control Circuitry	60
Control Valve.....	60
Chapter 8: Gas Correction Factor (GCF).....	61
The Gas Correction Factor (GCF):	61
How To Calculate the GCF for Pure Gases	61
How To Calculate the GCF for Gas Mixtures	62
Note	62
Example	63
Mass Flow Rate at a Different Reference Temperature	63
Direct Reading of the Analog Output Signal.....	64

Chapter 9: MFC Sizing Guidelines	65
General.....	65
Determining the Flow Controller Range.....	66
Configurations for Low or High Differential Pressure	66
Chapter 10: Maintenance	67
General.....	67
Zero Adjustment.....	67
Checks and Recalibration	67
Profibus Support Kit	68
Customer Support	68
Troubleshooting.....	69
Appendix A: Product Specifications	71
Specifications	71
Environmental Specifications	72
Electrical Specifications	72
Physical Specifications.....	73
Appendix B: Model Codes	75
Model Code	75
Type Number (XXXXA).....	75
SEMI Gas Code (YYY)	76
Calibration Gas Flow Rate (ZZZ).....	76
Fittings (F)	76
Valve (1).....	77
Electrical/Communication Connector (C).....	77
Seals (E)	77
Ordering Examples.....	78
To order a Mass Flow Controller	78
To Order a Mass Flow Meter	78
Appendix C: Gas Correction Factors	79
Appendix D: Binary Code	83
MKS Worldwide Calibration & Service Centers	85

There is a Health and Safety Form on the last page of this instruction manual.

List of Figures

Figure 1: Model Code Label.....	19
Figure 2: 1579A/B / 579A/B Side View	21
Figure 3: 1579A/B / 579A/B Connector Side.....	21
Figure 4: 1579A/B / 579A/B Gas Inlet Side.....	22
Figure 5: 15-pol. connector	23
Figure 6: 1579A/B / 579A/B Side View	24
Figure 7: 1579A/B / 579A/B Connector Side.....	24
Figure 8: 1579A/B / 579A/B Gas Inlet Side.....	25
Figure 9: 9-pol. Connector	26
Figure 10: Profibus Connector	27
Figure 11: 1579A/B / 579A/B Dimensions (Side).....	31
Figure 12: Dimensions (Inlet/Outlet side).....	32
Figure 13: Mounting Holes	32
Figure 14: Mounting Plate	33
Figure 15: Address and Mode Switch Map A/B	44
Figure 16: Voltage Divider.....	64

List of Tables

Table 1: MKS Cables	33
Table 2: Troubleshooting.....	69
Table 3: Binary Code.....	83

This page intentionally left blank

Safety Information

Symbols Used in This Instruction Manual

Definitions of WARNING, CAUTION, and NOTE messages used throughout the manual.

Warning!



The **WARNING** sign denotes a hazard. It calls attention to a procedure, practice, condition, or the like, which, if not correctly performed or adhered to, could result in injury to personnel.

Caution!



The **CAUTION** sign denotes a hazard. It calls attention to an operating procedure, practice, or the like, which, if not correctly performed or adhered to, could result in damage to or destruction of all or part of the product.

Note



The **NOTE** sign denotes important information. It calls attention to a procedure, practice, condition, or the like, which is essential to highlight.

Safety Procedures and Precautions

The following general safety precautions must be observed during all phases of operation of this instrument. Failure to comply with these precautions or with specific warnings elsewhere in this manual violates safety standards of intended use of the instrument and may impair the protection provided by the equipment. MKS Instruments, Inc. assumes no liability for the customer's failure to comply with these requirements.

DO NOT SUBSTITUTE PARTS OR MODIFY INSTRUMENT

Do not install substitute parts or perform any unauthorized modification to the instrument. Return the instrument to an MKS Calibration and Service Center for service and repair to ensure that all safety features are maintained.

SERVICE BY QUALIFIED PERSONNEL ONLY

Operating personnel must not attempt component replacement and internal adjustments. Any service must be made by qualified service personnel only.

USE CAUTION WHEN OPERATING WITH HAZARDOUS MATERIALS

If hazardous materials are used, observe the proper safety precautions, completely purge the instrument when necessary, and ensure that the material used is compatible with the wetted materials in this product, including any sealing materials.

PURGE THE INSTRUMENT

After installing the unit, or before removing it from a system, purge the unit completely with a clean, dry gas to eliminate all traces of the previously used flow material.

USE PROPER PROCEDURES WHEN PURGING

This instrument must be purged under a ventilation hood, and gloves must be worn for protection.

DO NOT OPERATE IN AN EXPLOSIVE ENVIRONMENT

To avoid explosion, do not operate this product in an explosive environment unless it has been specifically certified for such operation.

USE PROPER FITTINGS AND TIGHTENING PROCEDURES

All instrument fittings must be consistent with instrument specifications, and compatible with the intended use of the instrument. Assemble and tighten fittings according to manufacturer's directions.

CHECK FOR LEAK-TIGHT FITTINGS

Carefully check all vacuum component connections to ensure leak-tight installation.

OPERATE AT SAFE INLET PRESSURES

Never operate at pressures higher than the rated maximum pressure (refer to the product specifications for the maximum allowable pressure).

INSTALL A SUITABLE BURST DISC

When operating from a pressurized gas source, install a suitable burst disc in the vacuum system to prevent system explosion should the system pressure rise.

KEEP THE UNIT FREE OF CONTAMINANTS

Do not allow contaminants to enter the unit before or during use. Contamination such as dust, dirt, lint, glass chips, and metal chips may permanently damage the unit or contaminate the process.

ALLOW THE UNIT TO WARM UP

If the unit is used to control dangerous gases, they should not be applied before the unit has completely warmed up. Use a positive shutoff valve to ensure that no erroneous flow can occur during warm up.

This page intentionally left blank

Chapter 1: General Information

Introduction

The digital mass flow controllers of the 1579A/B series accurately measure and control the mass flow rate of gases. The type 579A/B of this series, however, is a mass flow meter for mass flow measurement only, therefore without a control valve.

Based upon a patented* MKS measurement technique, these instruments use a laminar flow device whose precise indication of mass flow is achieved through the use of a laminar bypass element in parallel with a sensor tube. The 1579A/B digital controllers use a PID algorithm which compares the flow signal with an external setpoint command, thus creating a control signal which is applied to a solenoid driven control valve to set the desired flow rate. The controllers also feature in the analog mode the ability to accept TTL level commands to remotely open and close the control valve. The control valve is located at the outlet of the meter section, also inside the metal instrument housing. The flow signal as derived from the sensor and also the analog setpoint signal are digitalized. Therefore linearization, flow control and handling of all other signals and commands is operated by the microcomputer, in both digital and analog versions of the 1579A/B series. This provides best accuracy and optimizes the controller's response and stability.

The 1579B/579B are the RoHS compliant version of the 1579A/579A and differentiate in the material selection of some components.

The 1579A/B controller and 579A/B meter employ a metal cover, providing excellent protection against electromagnetic disturbances. The RF bypass capacitors virtually eliminate RFI and EMI interference. The control valve of all mass flow controllers is a normally closed (NC) valve.

Overview of Versions

Type	Function	Features
1579A -Analog-	Mass Flow Controller	Standard flow control unit Analog setpoint and analog flow signal 0 – 5 VDC Control valve can be closed or opened remotely independent of setpoint. Full scale ranges (slm): 50, 100, 200, 300
1579A -Profibus-	Mass Flow Controller	Same as analog version but additional Profibus DP interface Setpoint and flow information in engineering units.
579A -Analog-	Mass Flow Meter	Standard flow monitor unit Flow signal analog 0 – 5 VDC Ranges: same as 1579A
579A -Profibus-	Mass Flow Meter	Same as analog version but with additional Profibus DP interface Flow information in engineering units.
1579B/579B		RoHS compliant version of the of the 1579A/579A

* US Patent No 5461913

Power Supply and Readout Units

The analog versions of the 579A/B/1579A/B series can interface to complementary MKS equipment which are available as single channel, dual channel, four and eight channel units to display the flow signal and to provide the power and set point commands, where applicable. Almost all control units are equipped with serial interface. Refer to the corresponding manuals for requirements and instructions.

Profibus Version

The particular features of units with Profibus interface, setup and control are described in *Chapter 6, Operation*.

Note: All Profibus versions can also be operated in analog mode, e.g. for diagnosis purposes. The analog interface and profibus interface connector are described in *Chapter 3 Connectors and Control Elements*.

The mechanical features and installation are the same for both the analog and profibus version.

CE and EMC Requirements

The instrument complies to EN61326-2-3 with the requirements for industrial applications with continuous not monitored operation. Braided shielded cables must be used. The PROFIBUS cable must be qualified.

Instruction Manual

Contents

This manual provides instructions on setup, installation, operation and service of:

- Mass flow controller 1579A/B / analog version
- Mass flow controller 1579A/B / profibus version
- Mass flow meter 579A/B / analog version
- Mass flow meter 579A/B / profibus version

Conventions

If not explicitly expressed differently at the respective place in this handbook all data are referenced to:

- a) Temperature in °C
- b) Gas type is nitrogen N₂
- c) Pressure
in mbar or bar with index (a) relating to absolute pressure whereas index (g) stands for gage pressure, related to atmosphere.

Example: 1,7 bar (g) = 1,7 bar overpressure versus atmosphere (gage pressure).
0,5 bar (a) = 500 mbar absolute pressure.

- d) Flow rates
are given in sccm** or slm*** related to nitrogen or dry air.

Designations and Names

The mass flow meter 579A/B will only be mentioned in particular where this is necessary, else wise the instructions for the 1579A/B also apply for the meter 579A/B.

In some places the appendix for version A is not printed, e.g. 1579 instead of 1579A/B without any restriction for functionality etc.

** 1 sccm = 1 standard cm³ / min ; standard conditions: 1013,25 mbar and 0 °C

*** 1 slm = 1 standard liter / min = 1000 sccm

This page intentionally left blank

Chapter 2: Shipment

General

Unpacking

MKS has carefully packed each unit so that it will reach you in perfect operating order. Upon receiving the unit, however, you should check for defects, cracks, broken connectors, damaged cables etc., to be certain that damage has not occurred during shipment.

Note

Do *not* discard any packing materials until you have completed your inspection and are sure the unit arrived safely.

If you find any damage, please notify your carrier and MKS immediately. If it is necessary to return the unit to MKS, obtain an ERA Number (Equipment Return Authorization Number) from the MKS Service Center before shipping. Please refer to the inside of the back cover of this manual for a list of MKS Calibration and Service Centers.

Unpacking Checklist

Analog Units

Mass flow controller 1579A/B or mass flow monitor 579A/B, respectively

Accessory kit ZB-30 consisting of

- Mating connector D-type; 15 pin female
- 2 mounting screws #8-32 UNF (MKS part no. 160-3973)

Manual (this book)

Calibration sheet

Optional:

Mounting plate

Diagnosis adapter kit, ordering code DMC-SUPPORT_ANA , consisting of:

- Adapter
- Software
- Cable

The adapter is also available separately. Ordering code: ADAPTER-DMC-ANA.

Profibus Units

Mass flow controller 1579A/B or mass flow monitor 579A/B, respectively

Accessory kit ZB-27 consisting of

- Mating connector D-type; 9 pin female
- Mating connector D-type; 9 pin male
- 2 mounting screws #8-32 UNF (MKS part no. 160-3973)

GSD file (3,5" disc)

Manual (this book)

Calibration sheet

Optional:

Profibus support kit, ordering code 1579-PB-SUPPORT consisting of:

1 Disc 3,5"

1 RS 232 cable

1 converter RS232/RS485

1 instructions

Label

The label shows the following information:

See figure 1 as an example:

Model code	1579A/B, for other codes ref. to appendix B
Sealing	Viton
Range	200 slm
Gas type	N2 (the range is related to this gas)
Serial number	560942G20
CE mark	CE
Manufacturer	MKS Instruments Deutschland GmbH



Figure 1: Model Code Label

Across the housing and the meter/controller body there is an extra label to avoid access to the inside by unauthorized people. Broken or removed label means lost of any warranty.

Clean Room Packaging

It is possible to get the flow controllers and meters delivered in clean room packaging (as an option). When unpacking, follow these steps, please:

1. Remove the outer bag in an ante room (garmenting room) or transfer box. Do not allow this outer bag to enter the clean room.
2. Wipe down the exterior of the inner bag with a clean room wipe. This step reduces the contamination introduced into the clean room.
3. Remove the inner bag in the clean room.

This page intentionally left blank

Chapter 3: Connectors and Control Elements

Analog Units

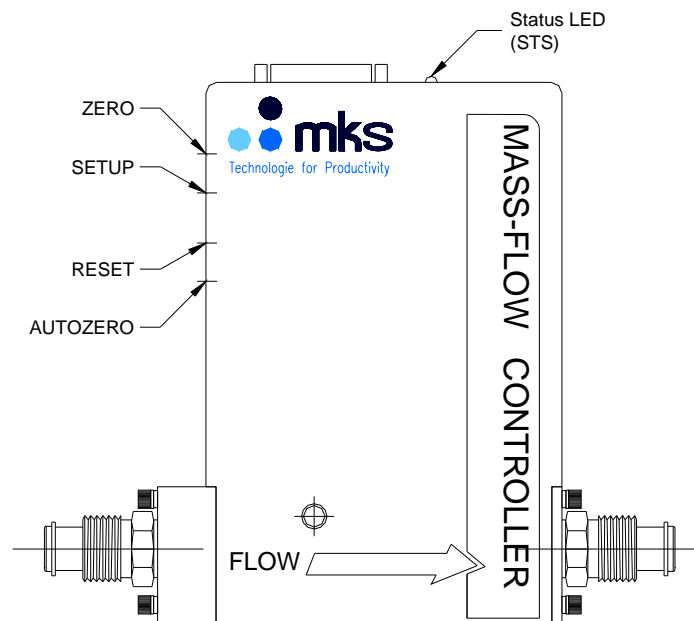

Figure 2: 1579A/B / 579A/B Side View
(Imprint on type 579A/B: MASS-FLOW METER)

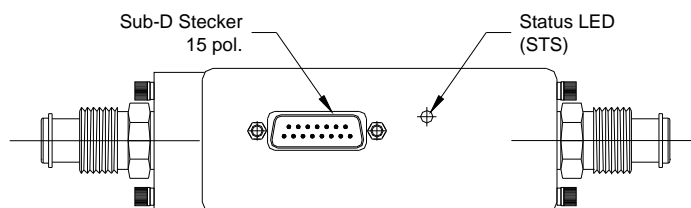

Figure 3: 1579A/B / 579A/B Connector Side

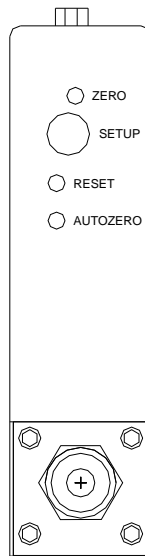

Figure 4: 1579A/B / 579A/B Gas Inlet Side

Potentiometer ZERO

Use this 25 turn potentiometer to adjust the signal output to zero.

Refer to *Chapter 5, Zero Adjust*.

AUTOZERO

Instead of potentiometer ZERO you can use this push button to zero the signal output.

Refer to *Chapter 5, Zero Adjust*.

RESET Switch

After pressing the RESET key the unit performs a self check cycle and a reset. The same procedure is done after power on. During the cycle the two color LED, labeled STS, changes its color a few times between red and green.

Finally the LED changes to green, indicating that self test cycle and reset have been completed successfully.

Connector SETUP

This access allows to modify the setup via special adapter and WINDOWS software. These tools may be ordered as a kit, ordering code DMC-SUPPORT-ANA. The adapter only is available as ADAPTER-DMC-ANA.

Note: Warranty is void when different connector or cable is used!

Electrical Connector

1579A/B / 579A/B, Analog Unit

(15 pol. Sub-D, male)

Pin	± 15 V Supply	24 V Supply	Note
1	Reserved	Reserved	
2	Flow Signal (0 to +5 V)	Flow Signal (0 to +5 V)	Referenced to pin 11 and 12
3	Valve Close ¹	Valve Close ¹	Connect to pin 5 to activate
4	Valve Open ¹	Valve Open ¹	
5	± 15 V Supply Common	reserved	
6	- 15 V Supply	+ 24 V Supply Common	
7	+ 15 V Supply	+24 V	
8	Setpoint Input ¹ (0 to +5 V)	Setpoint Input ¹ (0 to +5 V)	Referenced to pin 11 and 12
9	NC	NC	
10	NC	NC	
11	Signal Common	Signal Common	
12	Signal Common	Signal Common	
13	NC	NC	
14	NC	NC	
15	Chassis Ground	Chassis Ground	Shield, Case

Figure 5: 15-pol. connector

For use with control units from MKS Instruments (PR 4000, 647 etc.) we recommend to use the standard cables of the manufacturer.

Note



Any appropriate 0 to +5 V signal of less than 20 Ω source impedance can be used to supply a set point signal to pin 8. Cable must be equipped with a ferrite (Würth 742 712 21).

¹ Not applicable with mass flow meter 579A/B

Profibus Units

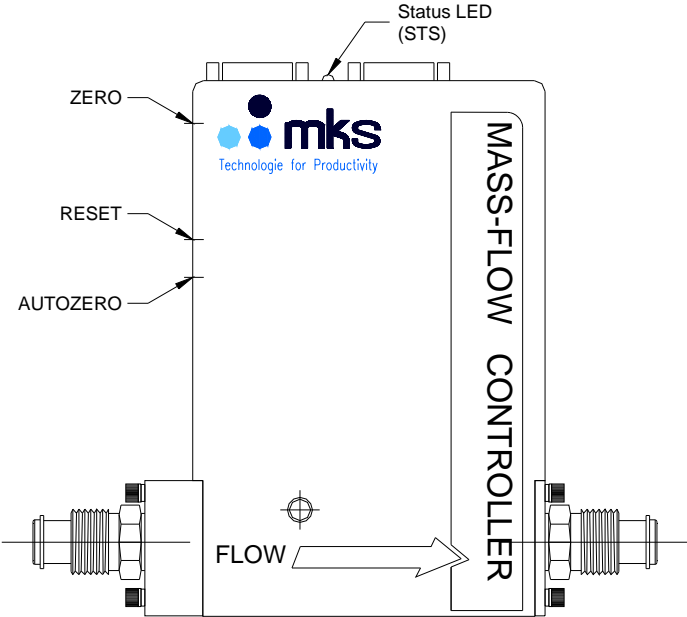

Figure 6: 1579A/B / 579A/B Side View
(Imprint on type 579A/B: MASS-FLOW METER)

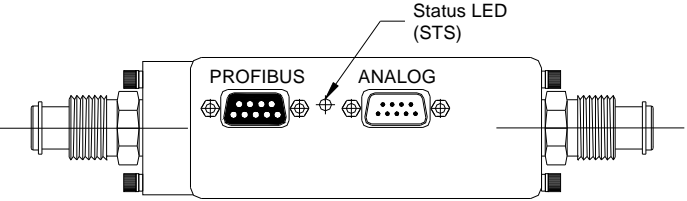

Figure 7: 1579A/B / 579A/B Connector Side

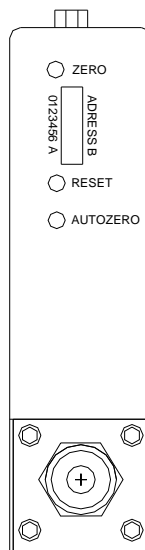

Figure 8: 1579A/B / 579A/B Gas Inlet Side

Potentiometer ZERO

Use this 25 turn potentiometer to adjust the signal output to zero.
Refer to *Chapter 6, Zero Adjust*.

AUTOZERO

Instead of potentiometer ZERO you can use this push button to zero the signal output.
Refer to *Chapter 6, Zero Adjust*.

RESET Switch

After pressing the RESET key the unit performs a self check cycle and a reset. The same procedure is done after power on. During the cycle the two color LED, labeled STS, changes its color a few times between red and green.

Finally the LED changes to green, indicating that self test cycle and reset have been completed successfully.

Address and Mode switch A/B

This switch selects either analog or Profibus mode. In Profibus mode you can set the address of the unit, in analog mode the mass flow controller requires an analog setpoint voltage.

Refer to *Chapter 6, Operation (Profibus Units)*, for detailed description.

Status LED STS

The Status LED provides two functions: Indicates the status of the instrument and indicates the Profibus address, at power on or on request.

The LED STS is explained more detailed in *Chapter 6, Operation (Profibus Units)*.

Electrical Connectors

1579A/B / 579A/B, Profibus Units, Connector ANALOG

(9 pol. Sub-D, male)

Pin	± 15 V Supply	24 V Supply	Note
1	Valve Open / Valve Close ^{1,2}	Valve Open / Valve Close ^{2,3}	
2	Flow Signal (0 to +5 V)	Analog operation not possible	Referenced to pin 7 and 8
3	+ 15 V Supply	+ 24 V Supply	
4	± 15 V Common	reserved	
5	- 15 V Supply	24 V Common	
6	Setpoint Input ²	Analog operation not possible	Referenced to pin 7 and 8
7	Signal Common	-	
8	Signal Common	-	
9	Reserved	Reserved	

Figure 9: 9-pol. Connector

For the use of the Profibus version in analog mode is a +/- 15 VDC power supply required. For the use in digital mode a +/- 15 VDC or a 24 VDC power supply is sufficient. This connector does not provide a particular pin for connection of the shield to the case. Connect the cable shield to the connector housing for grounding.

The cable must be equipped with a ferrite (Würth 742 712 21).

¹ To close the valve connect pin 1 to pin 5 (-15 V);
To open the valve apply + 5 V to pin 1 (referenced to pin 7 or 8).

² Not applicable with mass flow meter 579A/B

³ To close the valve connect pin 1 to pin 4;
To open the valve apply + 5 V to pin 1 (referenced to pin 7 or 8).

1579A/B / 579A/B, Profibus Units, Connector PROFIBUS**(9 pol. Sub-D, female)**

Pin	Signal	Note
1	NC	
2	NC	
3	RXD / TXD – P	Bus positive
4	CNTR – P	Control for Repeater, positive
5	DGND	Digital Ground
6	VP	Power Supply (5V)
7	NC	
8	RXD / TXP – N	Bus negative
9	NC	

Figure 10: Profibus Connector

This page intentionally left blank

Chapter 4: Operation

General Requirements

Environmental

Follow the guidelines below when installing and using your mass flow controller.

1. Maintain the normal operating temperature between 15 – 40 °C (59 and 104 °F).
2. Observe the pressure limits
 - Maximum gas inlet pressure is 7 bar (g).
 - Operational differential pressure is:

50, 100 slm	1,2 – 2,8 bar (g)
200 slm	1,9 – 2,8 bar (g)
300 slm	2,8 – 3,4 bar (g)
 - The standard orifice is sized for control over this range with the outlet atmospheric pressure.
3. Two kinds of power supply are possible (applies to all units):
± 15 V (±5%)
or
24 V (20,5 to 30,0 V)
Current: < 300 mA at startup and at steady state
4. Allow minimum 30 minutes for warm-up time for analog units as well as for units with profibus.
5. Use high purity gas to purge the instrument.
6. The use of a filter upstream of the mass flow controller is recommended, if enough pressure is available.

Refer also to *Appendix A, Product Specifications* for other possible precautions and restrictions.

Location and Orientation

1. Set the controller into position where it will be connected to a gas supply.

Placement of flow components in an orientation other than that in which they were calibrated (typically horizontal) may cause a small zero shift. The zero offset can be removed according to the instructions in *Chapter 5, Zero Adjust* if an analog unit is used or in *Chapter 6, Zeroing the Flow Controller* if a profibus unit is used.

2. Install the flow controller in the gas stream such that the flow will be in the direction of the arrow on the side of the controller.

Take into consideration the specified leak through the closed control valve in case of a mass flow controller. The specified value refers to new and unused units but may change during operation by age, cycles, temperature and gas. To achieve best possible leak tightness we strongly recommend the use of a positive shut off valve.

3. The normal position is horizontal, the electrical connector pointing upwards or vertical with flow direction either upwards or downwards.

It is possible to mount the units the way that the connector points downwards but control performance and valve leak can be affected. This applies especially to units with higher flow ranges. Therefore the 'ceiling mount attitude' should be avoided.

4. Allow adequate clearance for the tubing. Take into account when designing the plumbing that a unit may be removed later, e.g. for service or maintenance.

To de-install units with metal ferrule compression fittings (for example Swagelok) the tubing must be moved away some millimeters in axial direction whereas VCR fittings allow the instrument to be removed sideways also out from complexive and stiff plumbing systems.

5. Allow adequate clearance for the cable connector (two cable connectors in case of profibus version).

Straight, shielded connectors need about 75 mm clearance.

Right-angle connectors require about 50 mm space.

6. Position the unit to provide access to the zero potentiometer, in case of profibus units access to the dip switch bank and the RESET button:

Potentiometer or DIP-Switch / Button are located at the inlet side of the housing.

Make sure that the status LED is visible when installing units with profibus.

Leak Integrity

We recommend to check tightness of all ports and connections of the plumbing with a helium leak detector.

Pressure Drop Test

If a leak check at high pressure is intended then check for the highest allowable pressure for all parts involved. Example: If a pressure based leak check at 5 bar (g) is done you will damage a pressure transducer in the line if it is limited to 3,5 bar (g). In this case the pressure transducer (or whatever component is affected) must be removed or protected by a suitable valve.

Dimensions

Outline Dimensions

The overall outline dimensions (length, width, height) are identical for both the analog and Profibus Units.

(All dimensions are listed in millimetres. Conversion: 1 inch = 25,4 mm)

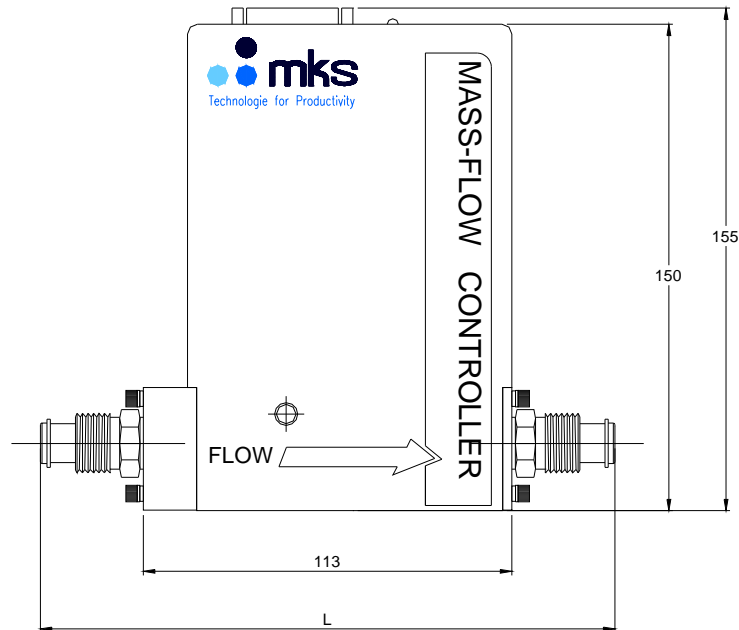

Figure 11: 1579A/B / 579A/B Dimensions (Side)

(Shown: analog unit; Imprint on type 579A/B: MASS-FLOW METER)

Fittings (compatible)	L in mm
8 VCR	183,0 ± 1
4 VCR	174,5 ± 1
8 VCO	174,0 ± 1
½ " Swagelok*	172,0 ± 1
12 mm Swagelok*	172,0 ± 1
DN 16 KF (code D)	162,0 ± 1
DN 16 KF (code H)	186,0 ± 1
DN 16 KF (code H)	201,0 ± 1
*) without nuts and ferrules	

(For dimensions with other fittings consult factory)



Figure 12: Dimensions (Inlet/Outlet side)

Mounting Holes

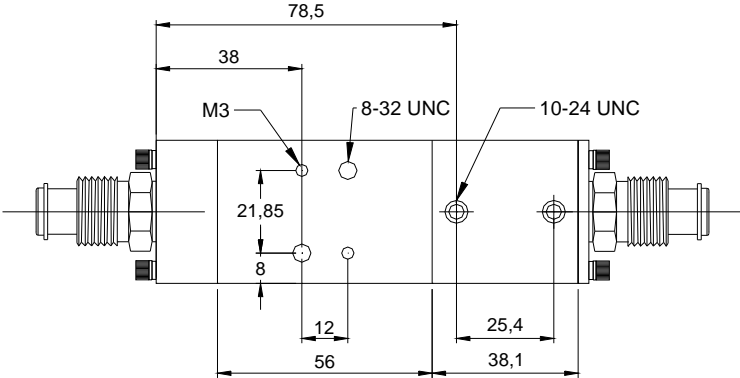

Figure 13: Mounting Holes

(Flow direction from left to right)

Mounting Plate

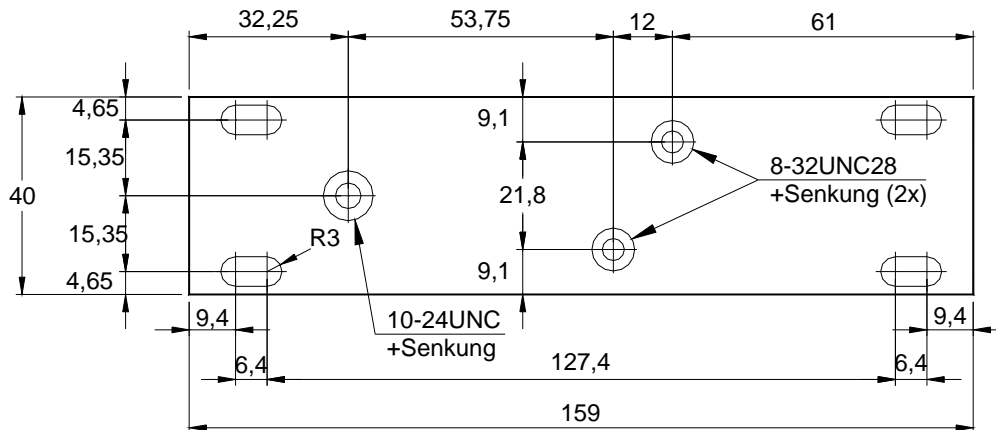

Figure 14: Mounting Plate

Electrical Connections and Cables

EMC Directive Requirements according to 2004/108/EC:

The instrument complies to EN 61326-2-3 with the requirements for industrial applications. Braided shielded cables must be used. The PROFIBUS cable must be qualified.

Cables and Controllers by MKS

For use of the analog versions of the types 579A/B and 1579A/B with controllers, power supplies, readout units etc. by MKS standard cables are available.

Flow Controller/Meter (Analog Version)	Control Unit	
	Sub D 15-pin	Flying Leads
Sub D 15 pin	CBE259-5	CBE259-6

Table 1: MKS Cables

Note: CE testing was done with the shielded cable, type CBE259-5.

Note



Use overall metal braided shielded cables, especially if the environment contains high EMI/RFI noise.

Power Supply / Readout Units of other Manufacturers

Should you use power supplies / readout units of manufacturers other than MKS then make sure that these units fulfil the electrical specifications for use with the mass flow controllers/meters as described herein. Refer to *Appendix A, Product Specifications*.

Non MKS Cables

Requirements

Should you choose to manufacture your own cables, follow the guidelines listed below:

1. The cable must have a braided shield, covering all wires. Neither aluminium foil nor spiral shielding will be as effective: using either may nullify regulatory compliance.
2. The connectors must have a metal case which has direct contact to the cable's shield on the whole circumference of the cable.
3. With very few exceptions, the connector(s) must make good contact (typical $0,01\Omega$ or less) to the device's case (ground). The case also must be properly grounded.
4. When selecting the cable, consider:
 - a) The voltage ratings.
 - b) The cumulative I^2R heating of all the conductors (keep them safely cool).
 - c) The IR drops of the conductors, so that adequate power or signal voltage gets to the device.
 - d) The capacitance and inductance of cables which are handling fast signals
 - e) If there are specific requirements when supply units etc of other manufacturers are used

Finishing the Installation

1. Check all fittings and flanges for leaks.

Do not proceed with the next step until you have not made sure that there are no leaks.
2. Connect the interface cable(s) to the mass flow controller.

Connect the other end of the cable to the power supply/control electronics.

Check all electrical connections.

This ends the mass flow controller's and mass flow meter's installation.

Chapter 5: Operation (Analog Units)

Start Up the Mass Flow Controller/Meter

1. After you have successfully checked all mechanical and electrical connections and when you are certain that there is no gas leakage, then power can be applied to the mass flow controller or to the flow meter, respectively.

The first start up should be done preferably using non-critical gas. This could be for example nitrogen or dry air (if there are no reactive residuals in the plumbing system) or any inert gas.

2. Switch on the power supply.

When power is first applied, the output signal jumps to + 7,5 V.

The unit performs automatically a reset, indicated by the red / green blinking status LED STS. Finally the LED changes to green light which indicates that the unit is ready for use.

You can monitor the flow output signal as the instrument stabilizes and the output approaches zero. Approximately 30 minutes after power up the signal should be stable within some millivolts close to zero.

Note

Do not use dangerous gases for the first start up. Use a non-critical gas, for example the gas which serves for purging.

Note

If the instrument is being used to control dangerous gases, be sure that the system is fully warmed *up* before applying gases to the system. You may choose to install a positive shutoff valve to prevent inadvertent gas flow during the warm-up period.

Once the instrument is completely warmed up, you can proceed to zero the unit as required.

Zero Adjust

1. If no gas is flowing and the mass flow controller has stabilized (ref. to *Appendix A, Specifications, Warm Up*) the flow output signal can be zeroed. This can be done in two different ways:
 - a) using the push button AUTOZERO, located at the gas inlet side of the unit. Use this means only when gas flow is completely stopped. Check that the flow signal has been set to zero!or
 - b) using the potentiometer ZERO, located at the gas inlet side of the unit. The potentiometer allows to adjust the zero signal to a known value of leak flow if completely shut off is not possible.
2. When using a control unit by MKS then you should use the zeroing means there. If the control unit does not provide enough compensation range then the potentiometer ZERO at the mass flow unit must be used.

Note



Zeroing should be done only on units that are installed in final position.

It is recommended to completely stop the gas flow prior to any zero adjustment.

If a pressure difference exists at the mass flow control unit then a small flow might occur even if the integrated control valve is closed. This is more likely with special units for low inlet pressures. Do not adjust the flow signal then to zero because it is a real flow but use a positive shutoff valve to definitely stop the flow.

The integrated control valve may not completely shut off the gas flow.

3. Periodically check the zero adjustment of the unit, e.g. on maintenance intervals. The zero adjustment is mainly affected by thermal effects and especially by contamination.

Beside the need for achieving measurements of highest accuracy the zero signal is a very important indication for diagnosing the condition of flow sensor and control valve.

Override the Control Valve

The valve override feature enables the control valve to be fully opened (purged) or closed independent of the set point command signal:

To open the valve, apply a TTL low to pin 4 or connect pin 4 to pin 5 (analog ground).

To close the valve, apply a TTL low to pin 3 or connect pin 3 to pin 5 (analog ground).

Priority of Commands

The 1579 flow controller executes commands based on a hierarchical command structure. The highest priority command is Valve Open, followed by Valve Close, and finally the Set Point Control. Therefore, if the flow controller is operating under Set Point Control, you can send a Valve Open command to force the valve to the full open position.

Note

When both the Valve Close and Valve Open pins are pulled down, the Valve Open command takes precedence and the valve is moved to the open position.

This page intentionally left blank

Chapter 6: Operation (Profibus Units)

Functions

Beside the normal flow control mode the units equipped with Profibus provide a number of helpful functions and useful information.

Overview

- Valve Override
- Auto Zero
- Totalizer, gas counter
- Gas Correction
- 15 Calibration Tables, 15 points each
- 4 Limit Alarms
- Run Hours Counter
- Remaining Time to Calibration Observation (Calibration Cycle Count Down)
- Temperature Measurement
- Valve Drive Level
- Status LED
- Signal Filter (flow signal)
- User Span setting
- User Zero setting
- User Tag

Report Functions:

Calibration Date, Type, Model, Manufacturer, Serial No., Firmware/Hardware Revision, Product Code, Date of Factory Calibration, Full Scale Range, Engineering Unit, Standard Temperature Standard Pressure, Valve Type, Valve Power Off Mode.

Valve Override

By means of an analog override signal applied to the respective pins at the connector ANALOG the control valve can be driven completely open or closed, independent of the setpoint command signal (only in analog mode). Refer to figure 9 and its explanations for the detailed description.

In Profibus mode the override however is only possible via the bus:

Set the parameter VALVE_OVERRIDE to NORMAL to allow the mass flow controller establishing a flow in accordance to the setpoint command FLOW_SETPOINT.

Set the parameter VALVE_OVERRIDE to FLOW_OFF to completely close the control valve.

Set the parameter VALVE_OVERRIDE to PURGE to completely open the control valve. This command may be used to purge or vent the instrument or the system.

Auto Zero

If VALVE_OVERRIDE is equal to FLOW_OFF and THERMAL_MASS_FLOW_RATE is smaller than 5 % of full scale, the flag AUTOZERO (0 to 1 transition) will take the actual sensor signal as zero and will subtract this value from all future measurements (refer also to *USER_ZERO*).

Note: Zero adjust can be performed also using the AUTOZERO button.

Alarm Limits

LOW_TRIP_POINT and HIGH_TRIP_POINT define the limits for LOW_LIMIT_ALARM and HIGH_LIMIT_ALARM flags. Consider that there is a 0.5% hysteresis for each limit switch. The hysteresis of 0.5% is divided in a slope 2.5% above and another slope 2.5% below the defined limit.

Temperature Measurement

The internal temperature of the device is measured in °C and given as INTERNAL_TEMP.

Valve Drive Level

The position of the valve is given in VALVE_DRIVE_LEVEL. 0% means that the valve is closed and 100% means that the valve is fully opened (e.g. at the PURGE command). A typical value under normal operating conditions is 40...60 % with new units. The value depends on many parameters, e.g. pressure conditions, temperature, contamination, age etc., and may change also during operation even at the same flow rate.

User Span / Gas Correction

For tuning the flow controller's accuracy the USER_SPAN parameter should be used and for application of a specific gas the nominal full scale (e.g. N₂) may be multiplied by the GCF of the gas and the parameter FULL_SCALE_RNG may be set with the result. Another option is to set the parameter GAS_CORRECTION to the GCF of the gas (full functionality only).

User Zero

The parameter USER_ZERO may be set to the flow sensors offset. (See also *AUTO ZERO*)

Filter

The filter is a single-pole low pass filter. The parameter that the user can adjust is the settling time of the filter (FILTER_SETTLING). E.g. if a step input (magnitude 100) is applied to the filter with a settling time of 100 second, the response out of the filter will be within 2% of the final value (98%) in 100 second. The default value is 0 seconds (no filtering).

Gas Tables

Gas tables may be switched off by setting the default table to 15 (i.e. no table is used) and by selecting the default table. Or by programming a 0 for POINT_NUM (ref. to *Calibration Table* at the end of this chapter; function (y=x)) and selecting it. Or by selecting a table with no (zero) points.

A backup of the Gas Tables is generated on Factory Setup. This backup is used for reset the tables.

Soft Start Rate

A change in the set point is performed in a slope, which is defined by SOFT_START_RATE.

Each controller is factory set to its optimum performance.

Start Up the Mass Flow Controller

1. After you have successfully checked all mechanical and electrical connections and when you are certain that there is no gas leakage, then power can be applied to the mass flow controller or to the flow meter respectively.

The first start up should be done preferably using non-critical gas. This could be for example nitrogen or dry air (if there are no reactive residuals in the plumbing system) or any inert gas.

2. Switch on the power supply.

When power is first applied, the output signal jumps to + 7,5 V.

The unit performs automatically a reset, indicated by the red/green blinking status LED. Finally the LED changes to green light which indicates that the electronic circuitry is ready for use.

3. You can monitor the flow output signal as the instrument stabilizes and the output approaches zero. Approximately 30 minutes after power up the signal should be stable within some millivolts close to zero.

Note

Do not use dangerous gases for the first start up. Use a non-critical gas, for example the gas which serves for purging.

Note

If the instrument is being used to control dangerous gases, be sure that the system is fully warmed up before applying gases to the system. You may choose to install a positive shutoff valve to prevent inadvertent gas flow during the warm-up period.

Once the instrument is completely warmed up, you can zero the unit if necessary.

Zeroing the Flow Controller

1. If no gas is flowing and the mass flow controller has stabilized (ref. to *Appendix A, Specifications, Warm Up*) the flow output signal can be zeroed. This can be done in different ways:

- a) using the push button AUTOZERO, located at the gas inlet side of the unit.

Use this means only when gas flow is completely stopped. Check that the flow signal has been set to zero!

or

- b) using the potentiometer ZERO, located at the gas inlet side of the unit. The potentiometer allows to adjust the zero signal to a known value of leak flow if completely shut off is not possible.

or

- c) via the Profibus interface

The Profibus version provides different modes for zero setting. If the mode switch A/B on the inlet side of the unit is set to mode B then parameter USER_ZERO in the PROFIBUS Setup is used. If set to mode A then 5 different options are provided, depending on the configuration of the address switches. Refer to *Zero Modes* in this chapter.

The command for zero setting also sets the analog flow output signal to zero (pin 2 on the connector ANALOG).

Note



Zeroing should be done only on units that are installed in final position.

It is recommended to completely stop the gas flow prior to any zero adjustment.

If a pressure difference exists at the mass flow control unit then a small flow might occur even if the integrated control valve is closed. This is more likely with special units for low inlet pressures. Do not adjust the flow signal then to zero because it is a real flow but use a positive shutoff valve to definitely stop the flow.

The integrated control valve may not completely shut off the gas flow.

2. Check that the respective flow signal (analog or Profibus) has been set to zero!
3. Periodically check the zero adjustment of the unit, e.g. on maintenance intervals. The zero adjustment may be affected by thermal effects and especially by contamination.

Beside the need for measurements of highest accuracy the zero signal is very important for diagnosing the flow sensor and the control valve.

Status LED STS

A two-color LED, marked STS, between the D-connectors, reports basic status information of the device. It is also used for setup and display of the PROFIBUS address.

LED Status	Meaning
off	No power or a severe fault
green	Ready
green blinking	Communication active
red	Fault condition
red blinking	Communication active but fault condition
green/red blinking	Wink flag was triggered
blinking green/red at power on	Device passes test step of software

Address and Mode Switch A/B

This switch map serves for manually switching from analog mode to Profibus mode and there to select the device's address. In analog mode a mass flow controller needs an analog setpoint signal!

If you are not familiar with the binary code refer to Appendix D how to convert decimal numbers.

Note: After changing any settings the unit must be restarted to store the new configuration.

Switch Assignment

Address Section							Mode	
ADDRESS							B	Top Label
0	0	0	0	0	0	0	Bus	Switch Up Value
1	2	4	8	16	32	64	Analog	Switch Down Value
0	1	2	3	4	5	6	A	Bottom Label

Figure 15: Address and Mode Switch Map A/B

Mode B

If the mode switch sets B mode, the device operates as PROFIBUS device. In that case the address switches define the device PROFIBUS address. If the address switches are all down (127) the internal programmed (via PROFIBUS) address is used. All other address switch settings define the PROFIBUS address by hardware.

Setting an Address

Example for address 5 in Profibus mode:

ADDRESS							B
	■		■	■	■	■	■
■		■					
0	1	2	3	4	5	6	A

Switch position = ■

Mode A

If the mode switch sets A mode, the device operates as an analog device. PROFIBUS may be used for monitoring and the bus address will be used, which was set previously in bus mode. The address switches in analog mode define the analog zeroing mode.

Example for setting analog mode and zero mode 3:

ADDRESS							B
		■	■	■	■	■	
■	■						■
0	1	2	3	4	5	6	A

Switch position = ■

Zero Modes

0	Offset Value is always Zero
1	Offset Value (USER_ZERO) stored in the device is not changed.
2	If the valve is off (VALVE_OVERRIDE == FLOW_OFF) for at least 10 sec. an AUTOZERO is performed.
3	10 sec. after reset, AUTOZERO is performed as long as valve is off. (value stored)
4	10 sec. after reset, AUTOZERO is performed if flow is smaller than 10% of FS. (value stored)

PROFIBUS Protocol

On diagnose data, the PROFIBUS protocol provides 6 bytes of PROFIBUS specific diagnosis information, which comes ahead of the application specific diagnosis data. After this data there is a length byte for the application specific diagnosis data. The total memory requirements are 6 + 1 + 'length of the diagnosis data'.

If the communication of the bus is interrupted a set point from the bus will be set to zero, as soon as the controller has recognized it. In the analog mode, the controller will not react to this event. Of course in any case, all readings from the device are not longer valid, but the PROFIBUS master will mark the device as not available.

Data Interface

The 1579 with PROFIBUS have a small data interface with a basic function set and a full data interface with the full function set of the device. The selection between small and full functionality is made at setup time with the type of configuration data, which is loaded down, to the device.

- Small / Full Parameter selects the internal function set and is declared by the GSD file parameters:

User_Prm_Data_Len and User_Prm_Data. The content of these parameters is either the small setup or full setup structure.

- Small / Full Receive Data, is selected by the MODULE definition in the GSD file. E.g.:

Module = "SMALL_MFC" 0x91, 0xD5, 0xA1, 0xE1 or
Module = "FULL_MFC" 0x91, 0xD7, 0xA1, 0xE1

The data interfaces are documented as data structures with consecutive fields. There is a table entry for each field, with name, address (add), type information and a comment for explanation. The address field (Add.) defines the byte and bit address (**ByteOffset:BitOffset**). For the memory layout big-endian is used. The following types are used:

- uint:X an unsigned integer with X bits length.
- long signed long integer (4 bytes)
- uint16 unsigned integer (2 bytes, word)
- uint8 unsigned integer (byte)
- char[X] character array of length X

Send Data

Name: SET_MFC
 Type: Cyclic Write (small & full)
 Size: 6
 Description: Analog Output Transducer Block, Small & Full Setup

Parameters:

Name	Add.	Type	Comment
VALVE_OVERRIDE	1:0	uint:2	NORMAL, FLOW_OFF, PURGE
AUTOZERO	1:2	uint:1	0 to 1 transition activates zeroing if (VALVE_OVERRIDE==FLOW_OFF && FLOW_SETPOINT < 5%FS)
REPORT_DIAG	1:3	uint:3	transition to a new value, triggers the device to send a new actual diagnosis: 0 = no diagnosis 1 = diagnosis of small functionality 2 = diagnosis of full functionality 3 = report selected gas table 4..7 = reserved
WINK_STATUS	1:6	uint:1	0 to 1 transition sets the LED to blink red/green for 3 seconds
ENABLE_TOTALIZER	1:7	uint:1	0 = disabled, 1 = enabled
RESET_TOTALIZER	0:0	uint:1	0 to 1 transition resets totalizer to zero
RESET_STATUS	0:1	uint:1	0 to 1 transition resets error status bits
SELECT_GAS_TABLE	0:2	uint:4	0..14; 15 = default gas table is used
EN_GAS_CORRECTION	0:6	uint:1	0 = disabled, 1 = enabled
Reserved	0:7	uint:1	
FLOW_SETPOINT	2:0	long	in [FLOW_UNIT] in 10E-4 steps valve switched off if setpoint < 1% valve switched on if setpoint > 2%

If the device is in the analog mode (i.e. set point is taken from the analog interface) some functions are not active:

1. VALVE_OVERRIDE is not active
2. EN_GAS_CORRECTION is not active
3. SELECT_GAS_TABLE is not active and the default table will be used

Small Receive Data

Name: FLOW_MFC
 Type: Cyclic Read (small)
 Size: 14
 Description: Analog Input Transducer Block

Parameters:

Name	Add.	Type	Comment
HIGH_LIMIT_ALARM	1:0	uint:1	(flow > HIGH_LIMIT), Hysteresis = 0.5%
LOW_LIMIT_ALARM	1:1	uint:1	(flow < LOW_LIMIT) , Hysteresis = 0.5%
SYSTEM_ERROR	1:2	uint:1	any severe error condition
Reserved	1:3	uint:5	
Reserved	0:0	uint:8	
THERMAL_MASS_FLOW_RATE	2:0	long	in [FLOW_UNIT] in 10E-4 steps
INTERNAL_TEMP	6:0	long	temperature in [°C] (in 10E-4 steps)
VALVE_DRIVE_LEVEL	10:0	long	0 .. 100% (in 10E-4 steps) 0% = valve is closed 100% = valve is in purge position (full open)

Full Receive Data

Name: FLOW_MFC
 Type: Cyclic Read (full)
 Size: 18
 Description: Analog Input Transducer Block. This block is used if a full setup was performed.

Parameters:

Name	Add.	Type	Comment
HIGH_LIMIT_ALARM	1:0	uint:1	(flow > HIGH_LIMIT), Hysteresis = 0.5% *
LOW_LIMIT_ALARM	1:1	uint:1	(flow < LOW_LIMIT) , Hysteresis = 0.5% *
SYSTEM_ERROR	1:2	uint:1	any severe system error condition
HIGH2_LIMIT_ALARM	1:3	uint:1	(flow > HIGH2_LIMIT), Hysteresis = 0.25%
LOW2_LIMIT_ALARM	1:4	uint:1	(flow < LOW2_LIMIT), Hysteresis = 0.25%
VALVE_CLOSED	1:5	uint:1	(THERMAL_MASS_FLOW_RATE < 1%) && (VALVE_OVERRIDE == FLOW_OFF)
PURGE	1:6	uint:1	THERMAL_MASS_FLOW_RATE > 110%
OVER_TEMPERATURE	1:7	uint:1	INTERNAL_TEMP > MAX_TEMP
VALVE_DRIVE_ALARM	0:0	uint:1	VALVE_DRIVE_LEVEL > MAX_VTP
CALIBRATION_RECOMMENED	0:1	uint:1	TIME_TO_CAL count down expired
UNCALIBRATED	0:2	uint:1	if a disabled or no table is used
CONTROLLER_ERROR	0:3	uint:1	abs (setp - flow) greater for a longer time period
MEMORY_FAILURE	0:4	uint:1	E2PROM checksum error
UNEXPECTED_CONDITION	0:5	uint:1	any process error condition
Reserved	0:6	uint:2	
THERMAL_MASS_FLOW_RATE	2:0	long	in [FLOW_UNIT] in 10E-4 steps
INTERNAL_TEMP	6:0	long	temperature in [° C] (in 10E-4 steps)
VALVE_DRIVE_LEVEL	10:0	long	0 .. 100% (in 10E-4 steps) 0% = valve is closed 100% = valve is in purge position (full open)
FLOW_TOTALIZED	14:0	long	in sl / sm3 (in 10E-4 steps) i.e. min. 298 days for a 500 range.

*) Hysteresis is +/- 0.25% (i.e. 0.5% in total) based on actual limit

Small Setup

Name: SMALL_SETUP
 Type: Initial Write (small)
 Size: 19

Parameters:

Name	Add.	Type	Comment
STRUCT_ID	0:0	uint8	0x10 (SMALL_SETUP)
INITIAL_SETUP	2:0	uint:1	THIS, ROM
BASE_UNIT	2:1	uint:1	Display in base unit
OPERATION_MODE	2:2	uint:1	0=ANALOG, 1=PROFIBUS
Reserved	2:3	uint:5	
Reserved	1:0	uint:8	
USER_SPAN	3:0	long	5% .. 200% in [%] (in 1E-4 steps)
USER_ZERO	7:0	long	-5% .. +5% of full scale (in 1E-4 steps)
HIGH_TRIP_POINT	11:0	long	-10% .. +120% of full scale (in 1E-4 steps)
LOW_TRIP_POINT	15:0	long	-10% .. +120% of full scale (in 1E-4 steps)

Full Setup

Name: FULL_SETUP
 Type: Initial Write (full)
 Size: 80

Parameters:

Name	Add.	Type	Comment
STRUCT_ID	0:0	uint8	0x11 (FULL_SETUP)
INITIAL_SETUP	2:0	uint:1	THIS, ROM
BASE_UNIT	2:1	uint:1	display in base unit
OPERATION_MODE	2:2	uint:1	0=ANALOG, 1=PROFIBUS
SET_USER_SPAN	2:3	uint:1	1=USER_SPAN will be updated
SET_USER_ZERO	2:4	uint:1	1=USER_ZERO will be updated
SET_HIGH_TRIP_POINT	2:5	uint:1	1=HIGH_TRIP_POINT will be updated
SET_LOW_TRIP_POINT	2:6	uint:1	1=LOW_TRIP_POINT will be updated
SET_GAS_CORRECTION	1:7	uint:1	1=GAS_CORRECTION will be updated
SET_DEFAULT_TABLE	1:0	uint:1	1=DEFAULT_TABLE will be updated
SET_HIGH2_TRIP_POINT	1:1	uint:1	1=HIGH2_TRIP_POINT will be updated
SET_LOW2_TRIP_POINT	1:2	uint:1	1=LOW2_TRIP_POINT will be updated
SET_FILTER_SETTLING	1:3	uint:1	1=FILTER_SETTLING will be updated
SET_SOFT_START_RATE	1:4	uint:1	1=SOFT_START_RATE will be updated
SET_TIME_TO_CAL	1:5	uint:1	1=TIME_TO_CAL will be updated
SET_CAL_DATE	1:6	uint:1	1=CAL_DATE will be updated
SET_USER_TAG	1:7	uint:1	1=USER_TAG will be updated
USER_SPAN	3:0	long	5% .. 200% in [%] (in 1E-4 steps)
USER_ZERO	7:0	long	-5% .. +5% full scale (1E-4 steps)
HIGH_TRIP_POINT	11:0	long	-10% .. +120% full scale (1E-4 steps)
LOW_TRIP_POINT	15:0	long	-10% .. +120% full scale (1E-4 steps)
GAS_CORRECTION	19:0	long	0.05 .. 2.00 (in 1E-4 steps)

(continued on next page)

Name	Add.	Type	Comment
DEFAULT_TABLE	23:0	uint8:4	0 .. 14 is the default table, 15 function (y=x) is the gas table
Reserved	23:4	uint8:4	
HIGH2_TRIP_POINT	24:0	long	-10% .. +120% full scale (1E-4 steps)
LOW2_TRIP_POINT	28:0	long	-10% .. +120% full scale (1E-4 steps)
FILTER_SETTLING	32:0	long	0.0 .. 1000.0 in [sec] (in 1E-4 steps)
SOFT_START_RATE	36:0	long	0.0 .. 3600.0 in [sec] (in 1E-4 steps)
TIME_TO_CAL	40:0	uint16	if SET_TIME_TO_CAL is 1 it will last TIME_TO_CAL hours until CALIBRATION_RECOMMENDED flag becomes active.
CAL_DATE	42:0	char[6]	MM/DD/YY
USER_TAG	48:0	chr[32]	any 32 character string

Small Diagnostics

Name: SMALL_DIAG
 Type: Diagnose (small)
 Size: 22

Parameters:

Name	Add.	Type	Comment
STRUCT_ID	0:0	uint8	0x20 (SMALL_DIAG)
Exception Status			
ALARM_DEVICE_COMMON	1:0	uint:1	specific to network (e.g. power fail)
ALARM_DEVICE_SPECIFIC	1:1	uint:1	specific to flow device (e.g. r/w EPROM)
ALARM_MKS_SPECIFIC	1:2	uint:1	specific to MKS
ALARM_TABLE_ERROR	1:3	uint:1	Reports cal. Table errors
Reserved	1:4	uint:4	
Identification:			
PRODUCT_CODE	2:0	uint16	1179
REVISION_CODE	4:0	uint8	A
VERSION_CODE	5:0	uint16	0x0100
Specification:			
FULL_SCALE_RNG	7:0	long	full scale range in [FLOW_UNIT] (in 1E-4 steps)
FLOW_UNIT	11:0	uint8	SCCM, SLM (SCCM is base unit)
Status:			
INTERNAL_TEMP	12:0	long	temperature in [°C] (in 10E-4 steps)
VALVE_DRIVE_LEVEL	16:0	long	0 .. 100% (in 10E-4 steps)
RUN_HOURS	20:0	uint16	hours

Full Diagnostics

Name: FULL_DIAG
 Type: Diagnose (full)
 Size: 217

Parameters:

Name	Add.	Type	Comment
STRUCT_ID	0:0	uint8	0x21 (SMALL_DIAG)
ALARM_DEVICE_COMMON	1:0	uint:1	specific to network (e.g. power fail)
ALARM_DEVICE_SPECIFIC	1:1	uint:1	specific to flow device (e.g. r/w EPROM)
ALARM_MKS_SPECIFIC	1:2	uint:1	specific to MKS (LinTab error)
ALARM_TABLE_ERROR	1:3	uint:1	Reports cal. Table errors
Reserved	1:4	uint:4	
PRODUCT_CODE	2:0	uint16	1179
REVISION_CODE	4:0	uint8	A
VERSION_CODE	5:0	uint16	0x0100
FULL_SCALE_RNG	7:0	long	full scale range in [FLOW_UNIT] (in 1E-4 steps)
FLOW_UNIT	11:0	uint8	SCCM, SLM
INTERNAL_TEMP	12:0	long	temperature in [°C] (in 10E-4 steps)
VALVE_DRIVE_LEVEL	16:0	long	0 .. 100% (in 10E-4 steps)
RUN_HOURS	20:0	uint16	hours
MANUFACTURER	22:0	char[20]	MKS INSTRUMENTS
MODEL_DESIGNATION	42:0	char[20]	1179AX12CGA4V
SERIAL_NUMBER	62:0	char[20]	999999 G
DEVICE_TYPE	82:0	char[6]	MFC, MFM
MODEL_TYPE	88:0	char[6]	1179
FIRMWARE_REVISION	94:0	char[6]	1.01
HARDWARE_REVISION	100:0	char[6]	A
FACTORY_CAL_DATE	106:0	char[6]	MM/DD/YY
VENDOR_CODE	112:0	uint16	0

(continued on next page)

Name	Add.	Type	Comment
STANDARD_TEMP	114:0	long	0 °C (in 10E-4 steps)
STANDARD_PRESSURE	118:0	long	101.1kPa (in 10E-4 steps)
VALVE_TYPE	122:0	uint8	0=SOLENOID, 1=VOICE_COIL, 2=PIEZO_ELECTRIC
VALVE_POWER_OFF_MODE	123:0	uint8	0=CLOSED, 1=OPEN, 2=LAST_POS
GAS_TABLE_NUM	124:0	uint8	Number of gas tables programmed. i.e. values != 0 in GAS_CODE_OF_TABLE_I
GAS_CODE_OF_TABLE_I	125:0	uint8[15]	gas code of gas tables 0=no table (y=x)
POINT_NUM_OF_TABLE_I	140:0	uint8[15]	Point number of gas tables
TABLE_FLAGS	155:0	uint:1[15]	0=FACTORY; 1=USER; 1 means that the user has overwritten the gas table once. All these flags will be reset at factory setup.
ACTIVE_GAS_NAME	157:0	char[16]	e.g. N2, is name of DEFAULT_TABLE if there was no cyclic comm. In the past.
CAL_DATE	173:0	char[6]	MM/DD/YY
USER_TAG	579:0	char[32]	any 32 character string
REM_TIME_TO_CAL	211:0	uint16	Remaining TIME_TO_CAL
FLOW_TOTALIZED	213:0	long	in sl/sm3 (in 10E-4 steps) i.e. min. 298 days for a 500 range. No base unit feature.

Calibration Table

Name: CAL_TABLE
 Type: Initial Write, Diagnosis (full)
 Size: 140

Parameters:

Name	Add.	Type	Comment
STRUCT_ID	0:0	uint8	0x12 or 0x22 for diagnosis
GAS_TABLE_IDX	1:0	uint8	0..14
GAS_CODE	2:0	uint8	0..254 255 resets to factory setup
POINT_NUM	3:0	uint8	2..15 = table with 2 .. 15 points 0 = disables table 1 = enables table
GAS_NAME	4:0	char[16]	e.g. N2
SENSOR_VALS	20:0	long[15]	in [FLOW_UNIT] in 10E-4 steps
FLOW_VALS	80:0	long[15]	in [FLOW_UNIT] in 10E-4 steps

If a table is loaded, which is not strict monotonous, the table will be disabled (POINT_NUM = 0). If a table, with a not valid index, is loaded, no tables will be affected. In both case the error flag for the table will be set.

The calibration tables convert the measured value (SENSOR_VALS) to the true physical value (FLOW_VALS). If the actual measured value is between two SENSOR_VALS, the flow will be calculated by linear interpolation. If the measured value is outside of the table definitions, the first (last) straight line will be continued.

The GAS_CODE may be any definition for gases. It is not evaluated. The GAS_NAME may be any 16 character string. It is also not evaluated.

The calibration tables stored from the factory may be recalled by an GAS_CODE of 255. In this case the TABLE_FLAG in the full diagnostic is reset.

PROFIBUS Setup

GSD Files Usage

A GSD File describes the device and defines the configuration (Parameter) for the actual application. The 1579PB may have different configurations: Small Setup, Full Setup and Calibration table. The Standard GSD file uses a default parameter set in the Small Setup structure. Others may be defined.

The 1579PB is a device, which normally would be looked at, as one module. This is also the definition in the standard GSD File. But it could be an advantage, to look at it as a device, which consists of 4 modules, one for each data block type (digital input, analog input, digital output, analog output). See the section of a GSD file with 4 module below.

Note:

At the release of this instruction manual the GSD file was **FlowGSD.gsd.1179.R1.0.gsd** from 6.2.03

```

;=====
; GSD-File for 1179B                                     MKS Instruments
; Date   : 06.02.03  V1.2  SL
; File   : "MKS1179.GSD"
;=====
#Profibus_DP
;----- <Unit-Definition-List> -----
GSD_Revision=2
Vendor_Name="MKS"
Model_Name="MKS1179B00"
Revision="B"
Ident_Number=0x1179
Protocol_Ident=0                ; PROFIBUS DP
Station_Type=0                  ; DP Slave
FMS_supp=0
Hardware_Release="R013"
Software_Release="V1.07"
Implementation_Type="SPC3"
;Bitmap_Device=""
;Bitmap_SF=""
; supported Baudrate
9.6_supp=1
19.2_supp=1
93.75_supp=1
187.5_supp=1
500_supp=1
1.5M_supp=1
3M_supp=1
6M_supp=1
12M_supp=1
; Default TSDR

```

```

MaxTsdr_9.6=60
MaxTsdr_19.2=60
MaxTsdr_93.75=60
MaxTsdr_187.5=60
MaxTsdr_500=100
MaxTsdr_1.5M=150
MaxTsdr_3M=250
MaxTsdr_6M=450
MaxTsdr_12M=800
;----- <Slave Specification> -----
;OrderNumber=""
Freeze_Mode_supp=1
Sync_Mode_supp=1
Auto_Baud_supp=1
;Fail_Safe=0
Min_Slave_Intervall=1
Max_Diag_Data_Len=220
Slave_Family=0@MKS                ; Device Family
;Family_Name = ""
Modular_Station=1
Max_Module=1
Max_Input_Len=20 ;18
Max_Output_Len=10 ;6
Max_Data_Len=30 ;140
Redundancy=0
Repeater_Ctrl_Sig=2
24V_Pins=0
Set_Slave_Add_supp=1
Max_User_Prm_Data_Len=237
;----- <Module-Definition-List> -----
Module = "SMALL_MFC" 0x91, 0xD5, 0xA1, 0xE1                ; small
send/receive
Ext_Module_Prm_Data_Len=19
Ext_User_Prm_Data_Const(0)=\
    0x10,0x00,0x04,0x00,0x0f,0x42,0x40,0x00,0x00,0x00,\
    0x00,0x00,0x0d,0xbb,0xa0,0x00,0x01,0x86,0xa0
;Ext_User_Prm_Data_Ref(?) = ?
;Ext_User_Prm_Data_Ref(?) = ?
EndModule
Module = "FULL_MFC" 0x91, 0xD7, 0xA1, 0xE1                ; full analog output
Ext_Module_Prm_Data_Len=80
Ext_User_Prm_Data_Const(0)=\
    0x11, 0xff, 0xfc, 0x00, 0x0f, 0x42, 0x40, 0x00, 0x00, 0x00, \
    0x00, 0x00, 0x0c, 0x35, 0x00, 0x00, 0x01, 0x86, 0xa0, 0x00, \
    0x00, 0x2e, 0xe0, 0x01, 0x00, 0x0f, 0x42, 0x40, 0x00, 0x00, \
    0xc3, 0x50, 0x00, 0x00, 0x00, 0x00, 0x00, 0x00, 0x00, 0x00, \
    0x00, 0x01, 0x30, 0x33, 0x32, 0x33, 0x36, 0x39, 0x55, 0x6c, \
    0x72, 0x69, 0x63, 0x68, 0x20, 0x48, 0x6f, 0x6c, 0x65, 0x73, \
    0x63, 0x68, 0x61, 0x6b, 0x00, 0x00, 0x00, 0x00, 0x00, 0x00, \
    0x00, 0x00, 0x00, 0x00, 0x00, 0x00, 0x00, 0x00, 0x00, 0x00
;Ext_User_Prm_Data_Ref(?) = ?
;Ext_User_Prm_Data_Ref(?) = ?
EndModule

```

Chapter 7: Theory of Operation

Technique of Measurement and Control, Electronics

The design of the 1579A/B flow controller incorporates an advanced flow sensor, a new control valve and an optimized bypass. The latest generation two-element sensing circuit provides accurate, repeatable performance. Low temperature effect from ambient temperature change and a low altitude sensitivity effect are also ensured. The newly optimized sensor/bypass arrangement minimizes the flow splitting error for gases with different densities, which dramatically improves measurement accuracy when gases other than the calibration gas are used.

The surface mount digital, processor controlled electronic circuitry allows optimum adjustment of the sensing and signal conditioning circuitry and provides tuned flow control for fast response to any set point in common with excellent stability.

The flow controller type 1579A/B measures and controls the gas flow rate accordingly to a given setpoint signal, which may be an analog signal or a digital command when using the Profibus version. The control range is from 2 % to 100% of full scale. The accuracy of the flow measurement is ± 1 % of full scale for both the analog units and Profibus versions.

Flow Path

Upon entering the flow controller, the gas stream passes first through the metering section of the instrument for its mass flow to be measured. The gas moves on through the control valve for its rate of flow to be regulated according to the given set point, and then exits the instrument at the established rate of flow.

The metering section consists of a sensor tube and a parallel bypass.

The geometry of the sensor tube, in conjunction with the specified full scale flow rate, ensures fully developed laminar flow in the sensing region. The bypass elements are specifically matched to the characteristics of the sensor tube to achieve a laminar flow splitting ratio which remains constant throughout each range.

Measurement Technique

The flow measurement is based on differential heat transfer between temperature sensing heater elements which are attached symmetrically to the sensor tube. This senses the thermal mass movement which is converted to mass flow via the specific heat, C_p , of the gas. The resulting signal is then amplified, digitalized and linearized. The corrected digital signal is then transferred to the control section (controllers only) and also converted into a 0 – 5 V analog signal.

Analog versions of the units described herein provide just the analog flow signal, Profibus versions provide both the digital information and the analog signal.

The measurement principle of keeping temperatures constant results in much shorter response time than conventional principles.

Control Circuitry

In the digital control section the flow rate is compared to the setpoint value and a control signal (digital) is generated.

The digital control signal is then conditioned by a PID-algorithm, optimized for fastest controlling and finally fed into the control circuitry which steers the solenoid control valve. The digital control reduces overshoots to a minimum and for completely regulating the flow until the difference from the setpoint is zero. Typical settling time is 1 s, for faster tuning contact MKS.

The control valve is closed when no power is applied (Normally Closed, N.O.). Controlling flow is done by levitating the valve plug from the valve orifice. The plug is mounted at the front end of the solenoid armature.

Control Valve

The control valve is a specially designed solenoid driven valve. The armature is suspended by springs. This design provides frictionless movement and thus precise control. Mounted at the front end of the cylindrical armature is the valve plug which incorporates the seal disc. Forced by the above mentioned springs the seal disc moves, when the solenoid is not activated, against the valve orifice, closing it's flow channel. Therefore the valve is closed when not activated. It is a „Normally Closed“ (N.C.) valve.

The inside diameter of the orifice determines the conductance. Each flow controller incorporates a valve orifice with a conductance in accordance to the full scale range. The valve orifice in standard units is sized that with a pressure difference between inlet and outlet fitting of typical 1,75 bar to 2,75 bar the specified full scale flow rate will be achieved. (related to air or nitrogen). For more information refer to *Appendix A, Specifications*.

The mass flow monitor 579A/B has no valve!

Chapter 8: Gas Correction Factor (GCF)

The Gas Correction Factor (GCF):

A Gas Correction Factor (GCF) is used to indicate the ratio of flow rates of different gases which will produce the same output signal from a mass flow meter / controller. The GCF is a function of specific heat, density, and the molecular structure of the gases. Nitrogen (N₂) is normally used as the baseline gas (GCF = 1) since flow meters and controllers are usually calibrated with nitrogen.

$$\text{GCF (N}_2\text{)} = 1$$

Appendix C lists the gas correction factors for many commonly used pure gases. If the gas you are using is not listed in there, you must calculate its GCF. The equations for calculating gas correction factors are described below.

How To Calculate the GCF for Pure Gases

To calculate the Gas Correction Factor for any pure gas (X), use the following equation:

$$\text{GCF}_x = \frac{0,3106 * s}{\rho_x * \text{cp}_x}$$

where:

GCF_x	= gas correction factor for gas X
0,3106	= (standard density of nitrogen) • (specific heat of nitrogen)
s	= molecular structure correction factor where S equals:
	1.030 for monoatomic gases
	1.000 for diatomic gases
	0.941 for triatomic gases
	0.880 for polyatomic gases
d_x	= standard density of gas X, in g/l (at 0° C and 1013,25 mbar)
cp_x	= specific heat of gas X, in cal/g° C

How To Calculate the GCF for Gas Mixtures

For gas mixtures, the calculated Gas Correction Factor is not simply the weighted average of each component's GCF. Instead, the GCF (relative to nitrogen) is calculated by the following equation:

$$\text{GCF}_x = \frac{0,3106 * (a_1s_1 + a_2s_2 + \dots a_ns_n)}{a_1\rho_1cp_1 + a_2\rho_2cp_2 + \dots a_n\rho_ncp_n}$$

where:

GCF _m	= gas correction factor for a gas mixture
0.3106	= (standard density of nitrogen) (specific heat of nitrogen)
a ₁ , a ₂ ,...a _n	= fractional flow of gases 1 through n <i>Note:</i> a ₁ through a _n must add up to 1.0
s ₁ , s ₂ ,...s _n	= Molecular Structure correction factor for gases 1 through n where S equals: 1.030 for monatomic gases 1.000 for diatomic gases 0.941 for triatomic gases 0.880 for polyatomic gases
d ₁ through d _n	= standard density for gases 1 through n, in g/l (at 0° C and 760 mmHg)
cp ₁ through cp _n	= specific heat of gases 1 through n, in cal/g° C

Note



1. When using the GCF, the accuracy of the flow reading may vary by ± 5%, however, the repeatability will remain ± 0,2% of FS.
2. The linearity and accuracy may be improved by calibrating the unit with the process gas or using a gas with equivalent properties (surrogat gas). Contact MKS for more information.
3. All MKS readouts have gas correction adjustment controls to provide direct readout.

Example

Calculate the GCF for a gas mixture of argon (gas 1) flowing at 150 sccm and nitrogen (gas 2) flowing at 50 sccm, where:

Argon (Ar)	Nitrogen (N ₂)
$a_1 = \frac{150}{200} = 0.75$	$a_2 = \frac{50}{200} = 0.25$
$s_1 = 1.030$	$s_2 = 1.000$
$d_1 = 1.782 \text{ g/l}$	$d_2 = 1.250 \text{ g/l}$
$cp_1 = 0.1244 \text{ cal/g } ^\circ\text{C}$	$cp_2 = 0.2485 \text{ cal/g } ^\circ\text{C}$

$$\begin{aligned}
 GCF_M &= \frac{(0.3106) [(0.75)(1.030) + (0.25)(1.000)]}{(0.75)(1.782)(0.1244) + (0.25)(1.250)(0.2485)} \\
 &= \frac{(0.3106) [(0.7725) + (0.25)]}{(0.1663) + (0.0777)} \\
 &= \frac{(0.3106) (1.0225)}{0.244} \\
 &= \frac{0.3176}{0.244} \\
 GCF_M &= 1.302
 \end{aligned}$$

Mass Flow Rate at a Different Reference Temperature

The equations for calculating the GCF assume that the MFC was calibrated at a reference temperature of 0° C (~273,15 K). If you want to read the mass flow as if the MFC was calibrated at a different reference temperature, adjust the calculated GCF value using the following equation:

$$GCF_x = GCF \times \frac{T_x}{T_N}$$

where:

T_x = actual reference temperature in °C

T_N = international standard temperature 0° C

Direct Reading of the Analog Output Signal

If a direct reading of output is desirable, and the readout equipment has no GCF potentiometer, a proper input divider may be constructed.

Example: Using a mass flow controller, full scale range 500 sccm N_2 , full scale signal is 5 VDC and a process gas CCl_4 . A flow rate of 100 sccm CCl_4 shall be converted into 1 VDC. As the gas correction factor of CCl_4 is 0,31 the flow signal must be divided 3.22 to 1.00 volts.

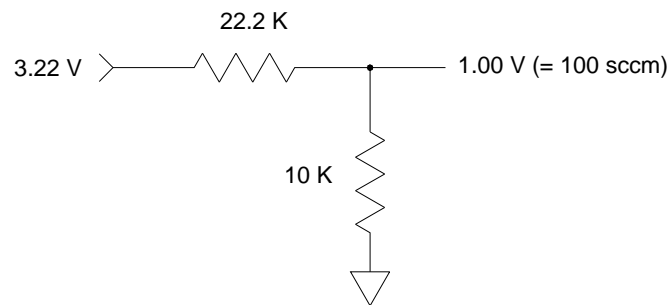

Figure 16: Voltage Divider

Note



All MKS readouts have gas correction adjustment controls to provide direct readout. The analog setpoint output signal is generated accordingly.

Chapter 9: MFC Sizing Guidelines

General

To select the correct MFC for an application, you must determine the:

- flow controller range
- appropriate valve configuration

The flow controller range depends on the desired flow rate and the gas correction factor for the gas to be used. MKS states the flow controller ranges based on flow rate of nitrogen; the flow rate for other gases may vary.

The proper valve configuration depends upon the flow range, inlet pressure, and differential pressure across the unit, and density of the gas. Proper valve configurations have been established for all standard flow ranges flowing nitrogen under standard operating pressures. These configurations are suitable for virtually all gases and pressure conditions.

Determining the Flow Controller Range

The Type 1579 controller is available in ranges of 50, 100 and 200 slm (N₂ equivalent). To select the appropriate range, you must determine the flow rate of nitrogen that is equivalent to the flow rate of the desired gas. Calculate the ratio of the GCF of nitrogen (1.00) to the GCF of the desired gas (refer to *Appendix C* as shown in the following example).

Example:

You need a flow rate of 130 slm of argon (Ar). What range flow controller should you use?

1. Find the Gas Correction Factor of Ar.

The GCF for Ar is 1.39.

2. Insert the GCF of Ar in the following formula:

$$(x) = (\text{Argon flow rate}) \times \text{GCF (N}_2) : \text{GCF (Ar)}$$

where x is the equivalent flow rate of nitrogen (sccm).

$$\frac{(1.00)}{(1.39)} = \frac{(x)}{(130 \text{ slm Ar})}$$

$$(x) = 93,5 \text{ slm N}_2$$

A flow rate of 93,5 slm of argon will produce a flow rate signal equivalent to 130 slm of N₂. This falls within the range of a 100 slm flow controller.

Note



When using a gas with a density higher than nitrogen, be sure that the control valve full scale range can accommodate the desired flow rate. Please call the MKS Applications group if you have any questions.

Configurations for Low or High Differential Pressure

The mass flow controllers are designed to operate under certain differential pressure conditions. Nominal values are listed in *Appendix A, Specifications*.

On request however, it is possible to provide special configurations for many applications with low or high pressure drops, respectively. A typical low pressure application for example is a vaporizer where liquid material is evaporated at low pressure and reasonable low temperature.

Chapter 10: Maintenance

General

After proper installation and correct setup there is typically only the need for occasionally checking and - if necessary - readjusting the zero flow signal. In general no further maintenance is required. How often the calibration and the valve should be checked depends on physical influences, e.g. temperature, vibrations, dust etc., is also related to the required accuracy and last not least on how the process gas affects the wetted parts inside the unit.

If a controller fails to operate properly upon receipt, check for shipping damage, and check the power/signal cable for correct continuity. Any damage should be reported to the carrier and MKS Instruments immediately.

Zero Adjustment

To achieve optimum accuracy and reliability you should periodically check the zero readout and - if necessary - readjusting it. For adjusting zero refer to the instructions in *Chapter 5; Chapter 6, Operation of Analog/Profibus Units*. How often the zero readout should be checked and corrected depends on the required accuracy and reproducibility the process is asking for.

Checks and Recalibration

Checks and recalibrations can be done by any service center of MKS (refer to section *Repair*). If nothing else is specified or shorter intervals are necessary we recommend annual maintenance and recalibration at a service center of MKS.

MKS offers many standard equipment for checking and calibrating mass flow meters / controllers to allow you making all testing and calibration.

For electronic testing and trouble shooting we recommend to do all measurements directly at the interface connector of the unit. This eliminates or detects erratic diagnosis, typically generated by incorrect grounding. MKS offers for this purpose so called breakout connectors. These are switched between the connector of the unit and the cable and provide a test pin for each wire, thus allowing direct access for a volt meter or oscilloscope etc.

Profibus Support Kit

This kit allows convenient setup and diagnosis of a Profibus mass flow meter/controller. It can be ordered from MKS as Profibus Support Kit, part no. 1179-PB-SUPPORT, consisting of

- 1 Disc 3,5"
- 1 RS 232 cable
- 1 Converter RS232/RS485
- 1 Instruction paper

Customer Support

Standard maintenance and repair services are available at all of our regional MKS Calibration and Service Centers, listed at the end of this manual. In addition, MKS accepts the instruments of other manufacturers for recalibration using the Primary and Transfer Standard calibration equipment located at all of our regional service centers. Should any difficulties arise in the use of your instrument, or to obtain information about companion products MKS offers, contact any authorized MKS Calibration and Service Center. If it is necessary to return the instrument to MKS, the MKS Calibration and Service Center will inform you about any formal requirements.

You will find a list of MKS Calibration and Service Centers and a form for Declaration of Contamination at the end of this handbook.

Warning



All returns to MKS Instruments must be free of harmful, corrosive, radioactive, or toxic materials.

Troubleshooting

Symptoms	Possible Cause	Remedy
No output or overrange at zero (after warm-up)	Improper cable Valve override function applied (Mass flow controller) Electronics malfunctioning	Check cable for type Disconnect / disable valve override Return for service
Unit indicates a negative flow	Unit installed in gas stream backwards	Reinstall unit in proper flow direction
Controller does not track set point.	Improper zero adjustment Improper grounding(s)	Zero meter output Check all ground connections. Check signals, if possible directly at the unit's connector
Controller does not function	Electronics malfunctioning Valve sticking, clogged, contaminated, corroded. Shutoff valve upstream or downstream closed No inlet pressure	Return for service Check compatibility of the process gas with materials wetted (corrosion is typically also visible inside the process fittings) Readjust the valve (return for service) Open shutoff valve first, then apply again setpoint to the unit. Regulate inlet pressure
Oscillation	Supply pressure unstable, e.g. defective pressure regulator. Supply pressure too high PID parameters not optimized	Check manufacturers' specifications Reduce upstream pressure <u>Profibus version only:</u> Optimize parameters (support kit DMC-SUPPORT-ANA required → Chapter 2)
Excessive closed conductance	Inadequate valve preload Valve seat elastomer damaged	Readjust the valve (return for service) Check compatibility of process gas with seat material Replace or change valve seat elastomer (return for service)
Unit does not achieve full flow	Upstream pressure too low Excessive valve preload Valve seat disc damaged, e.g. swollen	Increase upstream pressure Readjust the valve Check compatibility of process gas with seat material Replace or change valve seat elastomer (return for service)

Table 2: Troubleshooting

This page intentionally left blank

Appendix A: Product Specifications

Specifications

Accuracy ¹ Analog and Profibus version:	1 % of full scale
Control Range (MFC only)	2,0 % to 110% of full scale
Response Time	< 0,5 s
Controller Settling Time ²	< 1 s
Full Scale Ranges (nitrogen equivalent) ³	50, 100, 200, 300 slm
Operational Differential Pressure (MFC only) ⁴ 50, 100 slm 200 slm 300 slm	1,2 – 2,8 bar (g) 1,9 – 2,8 bar (g) 2,8 – 3,4 bar (g)
Maximum Inlet Pressure ⁵	6,8 bar (g)
Pressure Coefficient	0.3 % of reading/bar
Repeatability (MFC only)	± 0,2 % of full scale
Resolution (measurement)	0,1 % of full scale
Temperature Coefficients Zero Span	< 0.05 % of full scale /°C < 0,10 % of reading /°C
Warm Up Time	ca. 30 minutes

¹ Includes non-linearity, hysteresis and non-repeatability.

² Controller settling time per SEMI E17-91, specified for flows starting from 0 to 10% (or greater) of full scale.

³ sccm = std. cm³ / min ; standard (std.) condition: 1013,25 mbar and 0 °C.

⁴ Referenced to an MFC outlet pressure at atmosphere.

⁵ Flow control at 6,8 bar (g) inlet pressure requires special valve adjustment.

Environmental Specifications

Operating Temperature	15 to 40 °C (59 to 104 °F)
Storage Temperature	-20 to 80 °C

Electrical Specifications

Connectors Analog Version: Profibus Version:	Sub D 15-poles, pin Sub D 9-poles, pin (Analog Interface) Sub D 9-poles, socket (Profibus Interface)
Input Voltage/Current Required	20,5 to 30,0 VDC ¹ ; 300 mA
Output Impedance	< 1 Ω
Output Signal/Minimum Load	0 to + 5,5 V into > 10 kΩ
Set Point Command Signal (not for type 579A/B)	0 to + 5 V,5 from < 20 kΩ
CE and EMC	<u>Guideline:</u> 2004/108/EC <u>Conformity:</u> EN 61326 <u>Emission:</u> EN 55011 – Group1, Class A <u>Immunity:</u> EN 61000-4-2 EN 61000-4-3:2003 EN 61000-4-4 EN 61000-4-5 EN 61000-4-6:2001

¹ For the use of the Profibus version in analog mode is a +/- 15 VDC power supply required. For the use in digital mode a +/- 15 VDC or a 24 VDC power supply is sufficient.

Physical Specifications

Dimensions	refer to Chapter 4
Fittings: Standard Optional	Cajon® 8-VCR® male compatible Cajon® 8-VCO® male compatible 12 mm Swagelok compatible ½ " Swagelok compatible
Leak Integrity (mbar·l/s He) External Through closed Valve (MFC only)	< 1 x 10 ⁻⁹ < 0,1 % of full scale; test gas N ₂ at < 1 bar (g) at inlet and atmosphere at outlet <1 % of F.S. @ operational pressure at inlet and atmosphere at outlet
<u>Materials Wetted</u> Mass Flow Controller: Body Valve Standard Sealing Material Optional Mass Flow Meter:	316L SST Nickel Viton® Buna-N, Neoprene®, Kalrez® 316L SST
RoHS compliance	1579B and 579B
Mass	ca. 2.050 g

Due to continuing research and development activities, these product specifications are subject to change without notice.

This page intentionally left blank

Appendix B: Model Codes

Model Code

The desired instrument and options are identified in the model code when you order the unit. All parts of the product code apply to both the mass flow controller and the mass flow meter. These instruments are provided with digital boards and either digital or analog interfaces, depending on the connector code.

The model code is identified as follows:

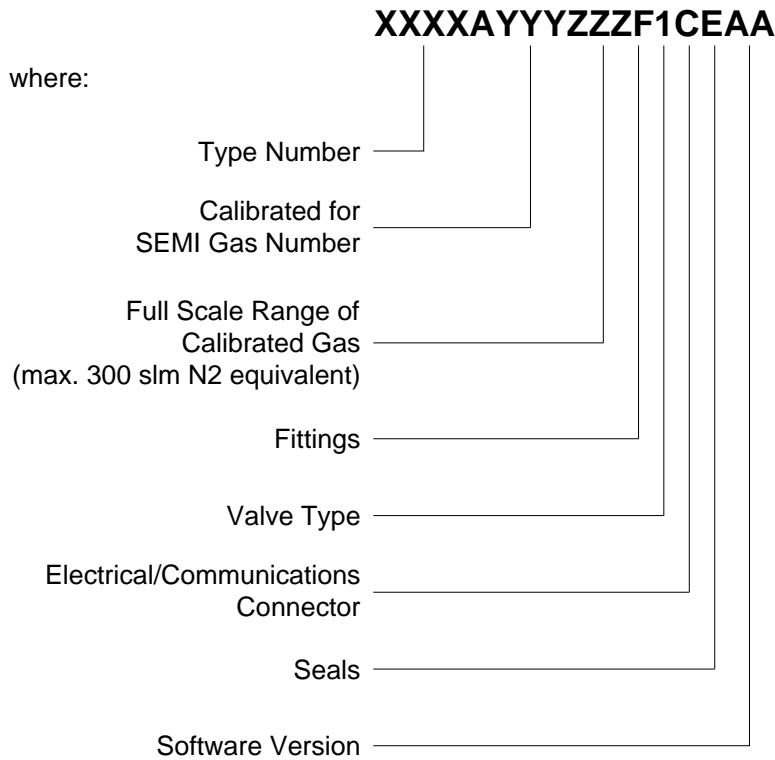

Type Number (XXXXA)

This Designates the Model Number of the instrument.

The Elastomer Sealed Mass Flow Controller is identified as Type **1579A**.

The Mass Flow Meter is identified as Type **579A**.

The **1579B** is the RoHS compliant version of the **1579A**.

The **579B** is the RoHS compliant version of the **579A**.

SEMI Gas Code (YYY)

The Gas to be calibrated for is identified as the SEMI Gas Code. A partial listing is shown below. The full list is shown in SEMI Document E052-0703, and may be found on the SEMI website www.semi.org, or a complete list shown on the MKS Website at www.MKSINST.com.

<u>Gas</u>	<u>Ordering Code</u>	<u>Gas</u>	<u>Ordering Code</u>
Helium	001	Carbon Dioxide	025
Argon	004	Methane	028
Hydrogen	007	Ammonia	029
Air	008	Silane	039
Nitrogen	013	Acetylene	042
Oxygen	015	Sulfur Hexafluoride	110
Chlorine	019	HMDSO	228
Si(CH ₃) ₄	301		

Calibration Gas Flow Rate (ZZZ)

The full scale range of the calibration gas flow rate in slm, not to exceed 300 slm N₂ equivalent.

<u>Flow, slm</u>	<u>Ordering Code</u>
50	51L
100	12L
200	22L
300	32L

Fittings (F)

	<u>Code</u>
Swagelok 8 VCR (compatible), male	R
Swagelok 4 VCR (compatible), male	V
Swagelok 8-VCO (compatible), male	G
Swagelok 1/2" tube compr. fitting (compatible)	S
Swagelok 12 mm tube compr. fitting (compatible)	M
DN 16 KF	D
DN 16 KF total length compatible to 1559A	N
DN 16 KF special length	H

Valve (1)

Two Valve configurations are available, designated by a single number code.

	<u>Ordering Code</u>
Normally Closed (MFC 1579A/B only)	1
No Valve (MFM 579A/B Only)	3

Electrical/Communication Connector (C)

The type of connector and communications is designated by a single letter/number code

	<u>Ordering Code</u>
Analog 15-Pin D	B
Digital Profibus (2 x 9-pin D)	4

Seals (E)

The seal material is indicated by a single letter code.

	<u>Ordering Code</u>
Viton, Standard	V
Buna-N	B
Neoprene	N
Kalrez	K

Ordering Examples

To order a Mass Flow Controller

To order an 1579A with 50,000 sccm FS for Helium with 8VCR Fittings, N/C Valve, 15 Pin D electrical connector, and Kalrez seals, the ordering code will be:

1579A 001 54C R 1 B K

To Order a Mass Flow Meter

To order a 579A for 100 slm Silane with 1/2" Swagelok fittings, Profibus communications and Viton seals, the ordering code will be:

579A 039 12L S 3 4 V

Note: The Profibus versions of the –79B MFC/MFM will have a software version appended to the end of the Model Code. This will change according the particular version in effect at the time of order placement. If a specific version of Profibus software is required, contact MKS Instruments for the correct addenda to the P/N.

Appendix C: Gas Correction Factors

Please read also the instructions in Chapter 8 and the notes at the end of this table.

Gas	Symbol	Specific Heat, Cp cal/g°C	Density g/l @ 0°C	Conversion Factor
Air	---	0,2400	1,293	1,00
Ammonia	NH ₃	0,4920	0,760	0,73
Argon	Ar	0,1244	1,782	1,39 ¹
Arsine	AsH ₃	0,1167	3,478	0,67
Boron Trichloride	BCl ₃	0,1279	5,227	0,41
Bromide	Br ₂	0,0539	7,130	0,81
Carbon Dioxide	CO ₂	0,2016	1,964	0,70 ¹
Carbon Monoxide	CO	0,2488	1,250	1,00
Carbon Tetrachloride	CCl ₄	0,1655	6,86	0,31
Carbon Tetrafluoride (Freon - 14)	CF ₄	0,1654	3,926	0,42
Chlorine	Cl ₂	0,1144	3,163	0,86
Chlorodifluoromethane (Freon - 22)	CHClF ₂	0,1544	3,858	0,46
Chloropentafluoroethane (Freon - 115)	C ₂ ClF ₅	0,164	6,892	0,24
Chlorotrifluoroethane (Freon - 13)	CClF ₃	0,153	4,660	0,38
Cyanogen	C ₂ N ₂	0,2613	2,322	0,61
Deuterium	D ₂	1,7220	0,1799	1,00
Diborane	B ₂ H ₆	0,5080	1,235	0,44
Dibromdifluoromethane	CBr ₂ F ₂	0,1500	9,362	0,19
Dichlorodifluoromethane (Freon - 12)	CCl ₂ F ₂	0,1432	5,395	0,35
Dichlorfluoromethane (Freon - 21)	CHCl ₂ F	0,1400	4,592	0,42
Dichlormethylsilane	(CH ₃) ₂ SiCl ₂	0,1882	5,758	0,25
Dichlorsilane	SiH ₂ Cl ₂	0,1500	4,506	0,40
1,2-Dichlortetrafluorethane (Freon - 114)	C ₂ Cl ₂ F ₄	0,1600	7,626	0,22
1,1-Difluorethylene (Freon - 1132A)	C ₂ H ₂ F ₂	0,2240	2,857	0,43
2,2-Dimethylpropane	C ₅ H ₁₂	0,3914	3,219	0,22
Ethane	C ₂ H ₆	0,4097	1,342	0,50

Table continued on next page

Gas	Symbol	Specific Heat, Cp cal/g°C	Density g/l @ 0°C	Conversion Factor
Fluorine	F ₂	0,1873	1,695	0,98
Fluoroform (Freon - 23)	CHF ₃	0,1760	3,127	0,50
Freon - 11	CCl ₃ F	0,1357	6,129	0,33
Freon - 12	CCl ₂ F ₂	0,1432	5,395	0,35
Freon - 13	CCIF ₃	0,1530	4,660	0,38
Freon - 13B1	CBrF ₃	0,1113	6,644	0,37
Freon - 14	CF ₄	0,1654	3,926	0,42
Freon - 21	CHCl ₂ F	0,140	4,592	0,42
Freon - 22	CHClF ₂	0,1544	3,858	0,46
Freon - 23	CHF ₃	0,1760	3,127	0,50
Freon - 113	C ₂ Cl ₃ F ₃	0,1610	8,360	0,20
Freon - 114	C ₂ Cl ₂ F ₄	0,1600	7,626	0,22
Freon - 115	C ₂ ClF ₅	0,1640	6,892	0,24
Freon - 116	C ₂ F ₆	0,1843	6,157	0,24
Freon - C318	C ₄ F ₈	0,1850	8,397	0,17
Freon - 1132A	C ₂ H ₂ F ₂	0,2240	2,857	0,43
Helium	He	1,2410	0,1786	---- ²
Hexafluorethane Freon - 116	C ₂ F ₆	0,1843	6,157	0,24
Hydrogen	H ₂	3,4190	0,0899	---- ²
Hydrogen Bromide	HBr	0,0861	3,610	1,00
Hydrogen Chloride	HCl	0,1912	1,627	1,00
Hydrogen Fluoride	HF	0,3479	0,893	1,00
Isobutylene	C ₄ H ₈	0,3701	2,503	0,29
Krypton	Kr	0,0593	3,739	1,543
Methane	CH ₄	0,5328	0,715	0,72
Methyl Fluoride	CH ₃ F	0,3221	1,518	0,56
Molybdenum Hexafluoride	MoF ₆	0,1373	9,366	0,21

Table continued on next page

Gas	Symbol	Specific Heat, Cp cal/g°C	Density g/l @ 0°C	Conversion Factor
Neon	Ne	0,2460	0,900	1,46
Nitric Oxide	NO	0,2328	1,339	0,99
Nitrogen	N ₂	0,2485	1,250	1,00
Nitrogen Dioxide	NO ₂	0,1933	2,052	---- ²
Nitrogen Trifluoride	NF ₃	0,5797	3,168	0,48
Nitrous Oxide	N ₂ O	0,2088	1,964	0,71
Octafluorocyclobutane (Freon - C318)	C ₄ F ₈	0,1850	8,937	0,17
Oxygen	O ₂	0,2193	1,427	0,993
Pentane	C ₅ H ₁₂	0,3980	3,219	0,21
Perfluoropropane	C ₃ F ₈	0,1940	8,388	0,17
Phosgene	COCl ₂	0,1394	4,418	0,44
Phosphine	PH ₃	0,2374	1,517	0,76
Propane	C ₃ H ₈	0,3885	1,967	0,36
Propylene	C ₃ H ₆	0,3541	1,877	0,41
Silane	SiH ₄	0,3189	1,433	0,60
Silicon Tetrachloride	SiCl ₄	0,1270	7,580	0,28
Silicon Tetrafluoride	SiF ₄	0,1691	4,643	0,35
Sulfur Dioxide	SO ₂	0,1488	2,858	0,69
Sulfur Hexafluoride	SF ₆	0,1592	6,516	0,26
Trichlorofluoromethane (Freon - 11)	CCl ₃ F	0,1357	6,129	0,33
Trichlorsilane	SiHCl ₃	0,1380	6,043	0,33
1,1,2-Trichloro - 1,2,2 Trifluoroethane (Freon - 113)	CCl ₂ FCF ₂ (C ₂ Cl ₃ F ₃)	0,1610	8,360	0,20
Tungsten Hexafluoride	WF ₆	0,0810	13,280	0,25
Xenon	Xe	0,0378	5,858	1,32

¹Empirically defined²Consult MKS Instruments, Inc. for special applications.

NOTE: Standard Pressure is defined as 1013,25 mbar (760 mmHg;14.7 psia), Standard Temperature is defined as 0°C.

This page intentionally left blank

Appendix D: Binary Code

The following table shows how to convert numbers from decimal code into binary code:

Decimal	Binary code	Decimal	Binary code
0	0000000	18	0010010
1	0000001	19	0010011
2	0000010	20	0010100
3	0000011	21	0010101
4	0000100	22	0010110
5	0000101	23	0010111
6	0000110	24	0011000
7	0000111	25	0011001
8	0001000	26	0011010
9	0001001	27	0011011
10	0001010	28	0011100
11	0001011	29	0011101
12	0001100	30	0011110
13	0001101	31	0011111
14	0001110	32	0100000
15	0001111
16	0010000	126	1111110
17	0010001	127	1111111

Table 3: Binary Code

This page intentionally left blank

MKS Worldwide Calibration & Service Centers

UNITED STATES

MKS Instruments, Inc.
Corporate Service Center
 651 Lowell Street
 Methuen, MA 01844
 Tel (978) 682-4567
 Fax (978) 682-8543

MKS Instruments, Inc.
HPS Division,
Vacuum Components,
Valves & Gauging
 5330 Sterling Drive
 Boulder, CO 80301
 Tel (303) 449-9861
 Tel (800) 345-1967
 Fax (303) 442-6880

CANADA

MKS Instruments, Canada Ltd.
 30 Concourse Gate
 Nepean, Ontario, Canada K2E 7V7
 (613) 723-3386
 Tel (800) 267-3551 (CAN only)
 Fax (613) 723-9160

FRANCE

MKS Instruments, France s.a.
 43, Rue du Commandant Rolland
 B.P. 41
 F-93352 Le Bourget, Cedex,
 France
 Tel 33(1)48.35.39.39
 Telex 233817 F
 Fax 33(1)48.35.32.52

TAIWAN

MKS Instruments, Taiwan
 10F, No.93, Shoei-Yuan Street
 Hsinchu City 300
 Taiwan, R.O.C.
 Tel 886-3-575 3040
 Fax 886-3-575 3048

GERMANY/BENELUX

MKS Instruments,
Deutschland GmbH
 Schatzbogen 43
 D-81829 München
 Tel 49-89-420008-0
 Fax 49-89-42-41-06
 Email: mks-germany@mksinst.com

ITALY

G. Gambetti Kenologia Srl.
 Via A. Volta No. 2
 20082 Binasco (MI), Italy
 Tel 39-2-90093082
 Fax 39-2-905.2778

JAPAN

MKS Japan, Inc.
 Harmonize Building
 5-17-13, Narita-Higashi
 Suginami-Ku, Tokyo 166, Japan
 Tel 81-3-3398-8219
 Fax 81-3-3398-8984

KOREA

MKS Korea Co., Ltd.
 1st Floor DK Plaza-I
 375-1 Geumgok-dong
 Bundang-gu, Seongnam Kyonggi-do
 Korea 463-805
 Tel 82-31-717-9244
 Fax 82-31-714-9244

UNITED KINGDOM

MKS Instruments, U.K. Ltd.
 1 Anchorage Court
 Caspian Road
 Altrincham, Cheshire
 WA14 5HH, England
 Tel 44-161-929-5500
 Fax 44-161-929-5511

SINGAPUR

MKS Instruments, Inc.
 BLK 4010 Techplace I
 #01-08/09 Ang Mo Kio Avenue 10
 Singapore 569623
 Tel (65) 6451 1062
 Fax (65) 6451 0172

Next page: Health and Safety Form

Contact MKS at the web or at any MKS location if the form is missing.

HEALTH AND SAFETY FORM

This form must be completed and returned with equipment or service will not be performed.

Return material authorization number (RMA#): (if applicable)	
Return to stock number (RTS#), (if applicable):	Trade in number (if applicable):

Section 1: (one Instrument per form)	MKS Part Number:
	MKS Serial Number:

Section 2: Has this equipment been used? *(Please check appropriate boxes)*

<input type="checkbox"/>	No – Still in MKS packaging
<input type="checkbox"/>	No – Unit unpacked, but never installed in a system.
<input type="checkbox"/>	Yes – Used only with clean, dry inert gas (For Example: Air, N2, Ar, He)
<input type="checkbox"/>	Yes – Used with chemicals, non-inert gases, biological or radioactive agents. Identify all materials:
<input type="checkbox"/>	Yes – Used in a Semiconductor Copper process. Equipment must be double bagged. Label outside bag and packing slip, Copper Part. Label final shipping container Copper Part and place a strip of ORANGE TAPE on the container.
Has equipment been purged? <input type="checkbox"/> No <input type="checkbox"/> Yes purged with what?	
Has equipment been flushed? <input type="checkbox"/> No <input type="checkbox"/> Yes flushed with what?	
Has equipment been decontaminated? <input type="checkbox"/> No <input type="checkbox"/> Yes explain process:	
How many months in use?	

Section 3: Detailed failure information or description or required service or reason for return.

Section 4: Company or Organization (mandatory information)

Company:		
Address:		
City:	State:	Zip:
Printed Name:	Signature:	
Date:	Phone #:	
Email:	Fax #:	
End User (if applicable):		

For MKS USE only:

MKS Subsidiary or Agent:
Contact Name:
Customer #:
Maximum Credit allowed (TBD after inspection)

ALL PRODUCTS MUST BE RETURNED IN SEALED BAGS

MKS will not accept delivery of equipment that has been chemically, radioactively or biologically contaminated, without written evidence of decontamination or laboratory analyses. Alternately, we will require evidence that the biological process is not harmful.