

The Ideal Vacuum Motor Conversion Kit PN: **MKIT-E182830** was specially designed and made to adapt American motors to European pumps. To be used on the following pumps:

EDWARDS Rotary Vacuum Pumps **E1M18, E2M18, E2M28, E2M30**



1. Parts List (PN: MKIT-E182830)

- | | |
|---|---|
| A. IVP Motor Adapter | E. Pump Bracket |
| B. (4) 3/8-16x1" screws (use a 5/16 allen key) | F. Pump Shaft Coupling (use 3mm allen key) |
| C. Motor Shaft Coupling (use a 1/8 allen key) | G. Spider |
| D. (4) 1/4-20x1" screws for the pump bracket (use a 3/16 allen key) | H. Use a 6mm key to install the (4) Pump Screws (Not included in the IVP Kit, these screws must come with the pump) |

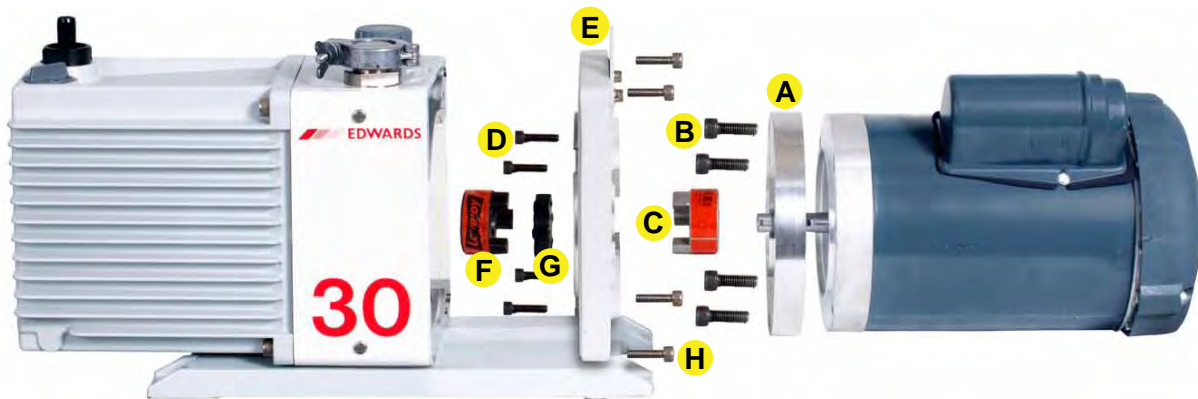

PLEASE FOLLOW THE INSTALLATION STEPS FOR SAFE AND PROPER MOTOR REPLACEMENT.

WARNING

Warnings are given where failure to observe the instruction could result in injury or death to people.

Wrong installation can cause malfunction or even critical damage to the motor and/or the pump.

Before starting the new motor installation, remove the old/damaged motor.

Clean the visible areas for preparation of the new motor.



Please review the next images to be sure the proper way to install the pump & motor shaft coupling. A wrong installation can cause malfunction or even critical damage to the motor and/or the pump. The pump & motor shaft coupling **MUST** be flush with the shaft. (as shown in the center image below)

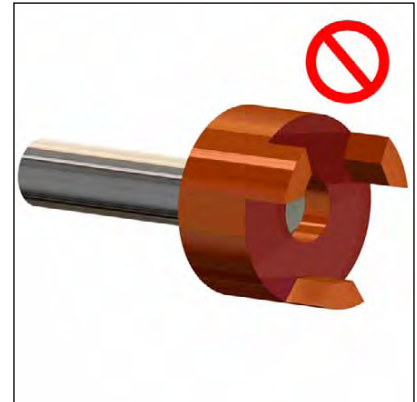
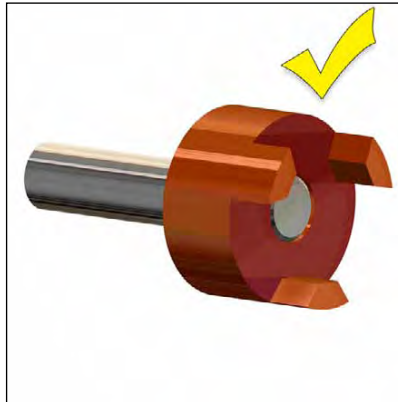
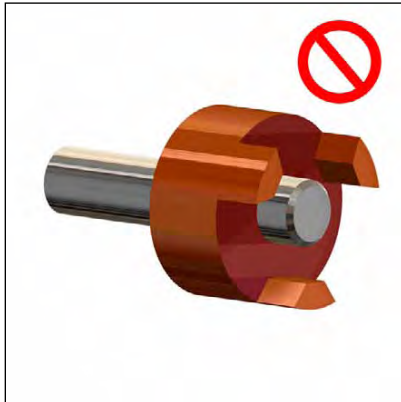

2. Motor Adapter Installation

- 2.1 Place and align the Motor Adapter (A) to the new motor.
- 2.2 Using the 3/8-16x1" screws (B) and a 5/16 allen key, install the motor adapter to the new motor.
- 2.3 Use a 1/8 allen key to install the 5/8" shaft coupling (C) to the motor. (MUST be flush with the motor shaft)
- 2.4 Install the pump bracket (E) using the (4) 1/4-20x1" screws (D) with a 3/16 allen key.

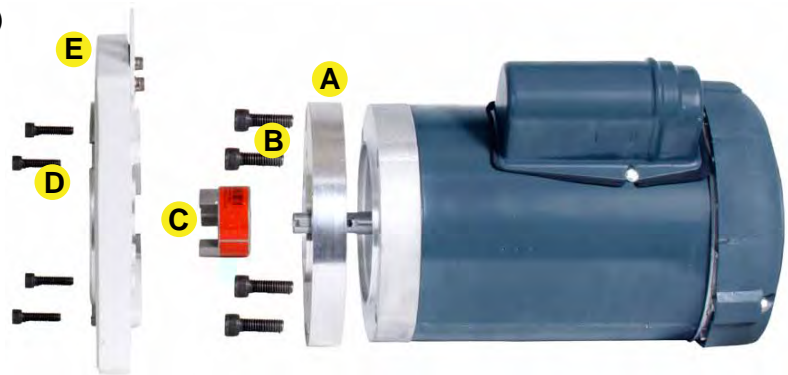

3. Pump Shaft Coupling Installation



- 3.1 Remove one of the pump side covers (S) to have more space to work around the shaft.
- 3.2 Install the 19 mm pump shaft coupling (F), tighten up with a 3 mm allen key. (MUST be flush with the shaft)
- 3.3 Install the spider (G) into the pump shaft coupling.

When you are done with the installation of all the parts on both, motor and pump, it will look something like the following image (depending on the motor and pump models)



4. Pump & Motor Final Assembly

4.1 Slide the pump and the new motor together using the pump screws (H) and a 6mm allen key.

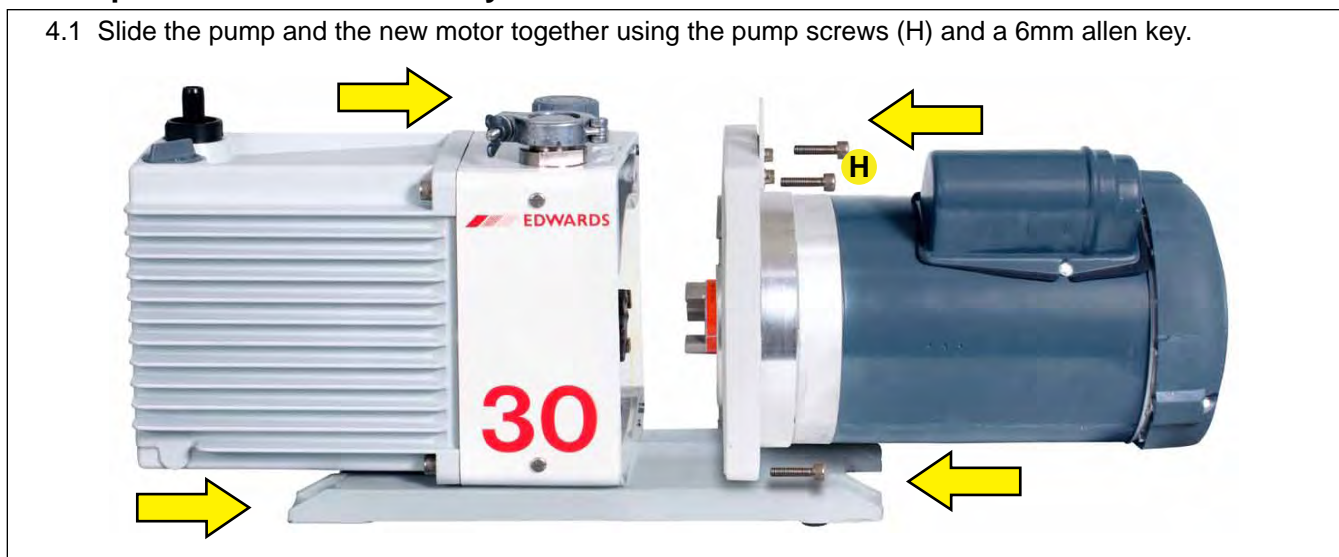

5. Pump & Motor Assembled Together

5.1 The pump with the new motor will look something like the following image (It depends of the pump model)

