

SOGEVAC® SV28 BI

Single-stage, oil-sealed
Rotary Vane Pump

Operating Instructions 300270050_002_C0
and Spare Parts list

Part Numbers

960 270 - 960 273

960 276 - 960 278

and their variants



Installation and operating instructions

These installation and operating instructions are valid for the SOGEVAC® pumps SV28 BI in their standard version.

Special versions to these pumps are delivered with an additive document, which prevails over the standard instructions.

The SOGEVAC® vacuum pumps have been manufactured according to the latest technical standards and safety regulations. If not installed properly or not used as directed, dangerous situations or damage could occur.

It is mandatory that these operating instructions be read and understood prior to vacuum pump installation and start-up.

	Page
1 General Instructions	3
1.1 Safety Instructions	3
1.2 Application range	5
1.3 Principle of operation	5
1.4 Technical characteristics	6
1.5 Accessories	8
1.6 Transport and Packing	9
1.7 Mounting orientation and storage	9
1.8 Lubricants	9
2 Installation	10
2.1 Setting-up	10
2.2 Inlet connection	10
2.3 Connection to exhaust side	10
2.4 Oil filling	10
2.5 Electrical connection	10
2.6 Operating advices	11
2.7 Shutdown	11
3 Maintenance	12
3.1 Oil level	12
3.2 Oil change	12
3.3 Exhaust filters replacement	13
3.4 Gas ballast valve cleaning	13
3.5 Inlet flange sifter cleaning	13
3.6 Anti-suckback valve checking	13
3.7 Fan cover cleaning	13
3.8 Checking the float valve	13
4 Breakdown analysis	13
5 Spare parts	14
6 Information	14
EC Conformance Declaration	
Declaration of contamination	
Spare Parts list	
Sales and Service	

1 General Instructions

1.1 Safety instructions

In this paragraph, the most important safety and usage instructions for the SOGEVAC® pumps are listed. Ahead of each following paragraph of the manual, the numbers of the applicable safety instructions will be listed.

Indicates procedures that must be strictly observed to prevent hazards to persons.

Indicates procedures that must be strictly observed to prevent damage to, or destruction of the product.

Emphasizes additional application information and other useful information provided within these Operating Instructions.

The Leybold Sogevac® has been designed for safe and efficient operation when used properly and in accordance with these Operating Instructions. It is the responsibility of the user to carefully read and strictly observe all safety precautions described in this section and throughout the Operating Instructions. The Sogevac® BI must only be operated indoor in the proper condition and under the conditions described in the Operating Instructions. If not, the protection provided by the equipment may be impaired. It must be operated and maintained by trained personnel only. Consult local, state, and national agencies regarding specific requirements and regulations. Address any further safety, operation and/or maintenance questions to our nearest office.

Failure to observe the following precautions could result in serious personal injury!

1.1.1

SOGEVAC® pumps are not designed:

- . for pumping of aggressive, corrosive, flammable or explosive gases or gases mixtures ;
- . for pumping of oxygen or other highly reactive gases with a greater concentration than atmospheric concentration (>20%) ;
- . for working in flammable or explosive environment.

For all these cases, special materials must be used. In case of doubt, please contact Leybold.

See also the limits of use indicated in the EC Declaration of Conformity.

1.1.2

Liquid and solid particles must not enter the pump. Install the adequate filters, separators and/or condensers. In case of doubt consult Leybold. Do not allow the ingestion of any objects (screws, welding beads, nuts, washers, pieces of wire, fittings etc.) through the intake port of the pump. Objects falling into the pump can cause severe damage.

Warning

Caution

Note

Warning



1.1.3

The intake line of the pump must never be connected to a device with over atmospheric pressure. Size of the exhaust line so that no pressure higher than 1,15 bar abs. (0,15 bar rel.) or depression of 15 mbar (0,15 bar rel.) can occur

1.1.4

Operating of the pump without oil or operating with incorrect sense of rotation can destroy the pump.

1.1.5

Never expose part of the body to the vacuum. There is a danger of injury. Never operate the pump with an open and thus accessible inlet. Vacuum connections as well as oil filling and oil draining openings must not be opened during operation of the pump.

Caution



1.1.6

Caution : hot surface !

in normal operation, the pump surface temperature can reach 85°C (185°F). There is a risk of burning. Switch off the pump and let it cool down before any intervention or take appropriate precautions.

It is recommended to use an oil casing or pump touching protection at high ambient temperatures. As a touching protection, you can use the noise enclosure P/N 960331NENC. The noise enclosure is an accessory not included in the pump delivery.

All work on a pump which is "still warm from operation" should be done only whilst wearing protective gloves. Handle the pump only while vented and after having let it cool down.

Never remove the oil-fill or oil-drain plugs while the pump is running. There exists the risk of suffering burns. Always wear protective gloves and protective goggles also for protection against the oil.

Warning



1.1.7

Depending on the process involved, dangerous substances and oil may escape from the pump. Take the necessary safety precautions ! Clean oil traces off the pump or floor !

1.1.8

Observe the safety regulations !

Never use discarded seals. Always assemble using new seals.

Respect the instructions concerning environment protection when discarding used oil or exhaust filters !

Caution



1.1.9

High electric voltages ! When touching parts at high electric voltages, there is the risk of suffering severe injuries by an electric shock ! Covers marked with this symbol must only be opened by trained electricians after having reliably deenergised (lockout/tagout) the equipment

Always operate the pump with a properly connected protective earth conductor and make sure that the motor connection box is closed.

Lay the connecting lines so that these cannot be damaged. Protect the lines against humidity and contact with fluids. Avoid thermally stressing the lines by unfavourable laying. Provide strain relief for the connecting lines so that the

plugs and the line connectors are not subjected to excessively high mechanical stresses.

Lay electric feed lines so that there is no risk of tripping over these.

1.2 Application range

See prescriptions chapters 1.1.1. and 1.1.2.

SOGEVAC® pumps are designed for pumping of inert gases in the range of medium vacuum, between atmospheric pressure and ultimate pressure of the pump. Pumps with single phase motors shall not operate in continuous duty over 50 mbar abs. Please advise Leybold if you are in such a case or if the chamber volume exceeds 50 l.

Indoor use up to 2000 m altitude and rel. humidity $\leq 95\%$ without condensation.

Ambiant temperature 1 ph. pumps 16 ... 40°C

Ambiant temperature 3 ph. pumps 12 ... 40°C

1.3. Principle of operation

The SOGEVAC® pumps SV28 BI are single-stage oil sealed rotary vane vacuum pumps. The rotor, having three slots in which the vanes are sliding, is eccentrically installed in a pump cylinder (stator).

The vanes separate the interior space into 3 chambers. The volume of these chambers varies with the rotation of the rotor.

The gas sucked into the inlet chamber is compressed and then pushed out at the exhaust valve.

The oil injected in the inlet chamber guarantees the air-tightness, the lubrication and cooling of the pump. It is dragged off by the compressed gases and roughly separated by gravity when entering in the oil sump. A fine separation is then operated in the exhaust filter. The exhaust filter retains $> 99,9\%$ of the aerosols. An internal transfer pushes the collected oil back into the vacuum generator, the transfer is operated by a float valve to avoid atmospheric air coming from the oil casing to the inlet of the pump when no oil is present in the recovery system.

The oil circulation functions by differential pressure.

Depending on catalog numbers, the pumps are equipped with a gas ballast valve for pumping condensable vapours.

The anti suckback valve at the inlet flange avoids oil coming back into the inlet line when the pump is stopped. This is valid for working pressures below 100 mbar and under the condition that the valve is kept clean and in good condition. The anti suck-back valve is not a safety valve. If oil back flowing is to be avoided by all means, it is necessary to mount a separate safety valve on the pump inlet.

The pumps P/N 960 276 and 960 277 and their variants are certified according Std. EN 61010-1 (2004).

This product has been tested to the requirements of CAN/CSA-C22.2 No 61010-1, second edition, including Amendment 1, or a later version of the same standard incorporating the same level of testing requirements.



37 A @ 240 V AC

General Instructions

1.4 Technical Characteristics

		50Hz	60Hz
Nominal pumping speed	m ³ .h ⁻¹	25	30
Pumping speed (according to Pneurop)	m ³ .h ⁻¹	23	27
Ultimate partial pressure without gas ballast	mbar	≤ 0,05	≤ 0,05
Ultimate total pressure with small gas ballast	mbar	≤ 0,5	≤ 0,5
Water vapour tolerance with small gas ballast	mbar	10	10
Water vapour tolerable load with small gas ballast	kg.h ⁻¹	0,07	0,08
Noise level (according to DIN 46635)	dB(A)	54	57
Mains voltage AC ~ 3 ph	V	230/400 (+/- 10%)	460 (+/- 10%)
Mains voltage AC ~ 1 ph	V	200 ... 240 (+/- 10%)	
Motor power - Rated rotational speed 3 ph	kW/rpm	0,75-1430	0,9-1720
Motor power - Rated rotational speed 1 ph		0,55-1440	0,66-1700
Pump protection - Motor isolation		IP55 - F IP40-F for single-phase motors	IP55 - F
Leak rate	mbar.l.s ⁻¹	1.10 ⁻³	1.10 ⁻³
Oil type / Capacity	l	0,5l or 1,5l	
Intake connection		25 KF	25 KF
Exhaust connection		25 KF	25 KF

Pump with three-phase motor, gas ballast, small oil casing 230 V/400 V, 50Hz ; 460 V, 60Hz	960 271
Pump with three-phase motor, gas ballast, big oil casing 400 V, 50Hz ; 230/460 V, 60Hz	960 273
Pump with single-phase motor wide range, gas ballast, small oil casing 180-264V, 50/60Hz	960 276
Pump with single-phase motor wide range, gas ballast, big oil casing 180-264V, 50/60Hz	960 277
Pump with JP and USA single-phase motor, gas ballast, big oil casing 100V -15/+10%, 50/60Hz & 115V -15/+10%, 60Hz	960 278

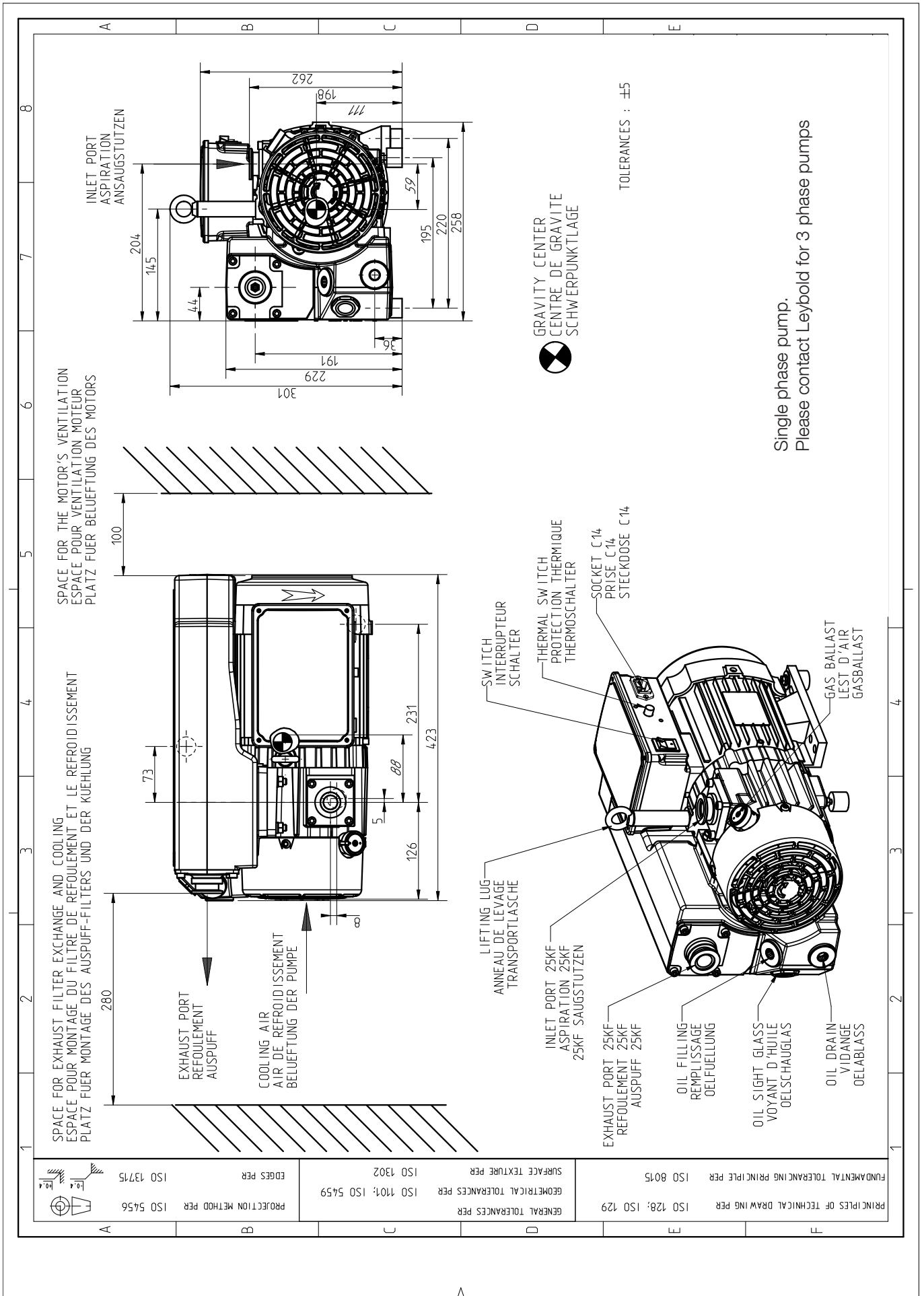

Single phase pump.
 Please contact Leybold for 3 phase pumps

Pumping speed curves

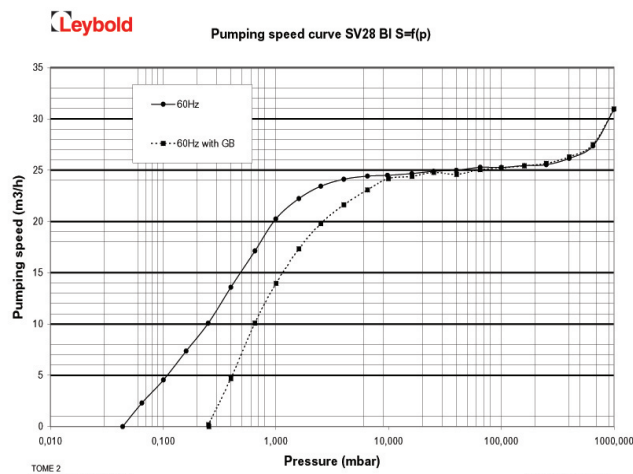
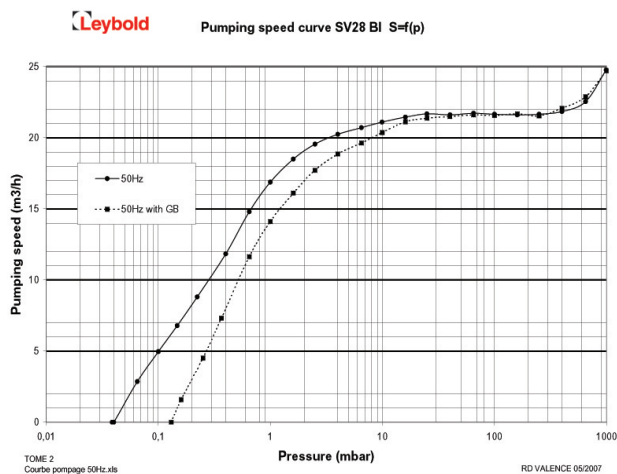

— without gas ballast - - - with gas ballast

1.5 Accessories

For the accessories, please refer to the Leybold General Catalogue chapters C01 and C13.

Kit anti suck back valve	9 714 62 600
Gas ballast kit	9 714 62 640
Gas ballast obturator	EK971473010
Set of seals	9 714 62 670
Float valve kit	9 714 62 660
Rubber feet kit	9 714 62 650
3 phase motor flange kit	9 714 62 630
Stator kit	9 714 62 620
Complete oil casing 0.5 l	9 714 49 400
Complete oil casing 1.5 l	9 714 54 140
Repair kit	9 714 62 690
Vacuum generator three phase pump	9 714 62 620
Vacuum generator single phase pump	9 714 62 630
Oil level switch	upon request no retrofit possible
Noise enclosure	960331NENC

1.6 Transport and Packing

SOGEVAC® vacuum pumps pass a rigorous operating test in our factory and are packed to avoid transport damages.

Please check packing on delivery for transport damages.

The outer package bears a shock indicator, turning red at 50 g. Should the shock indicator have reacted, a transportation damage may have occurred and the freight forwarder must be advised.

Packing materials should be disposed off according to local environmental laws or re-used.

These operating instructions are part of the consignment. The connection ports are blanked off by plastic protective caps or self-adhesives. Take these caps or self-adhesives away before turning on the pump.

The necessary oil is supplied in a can beside the pump.

1.7 Mounting orientation and storage

1.7.1 Mounting orientation :

See required space on chart in paragraph 1.4. Pumps which have been filled with operating oil must only be moved in the upright position (horizontally). Otherwise oil may escape. The angle of slope may not be over 10° max. Avoid any other orientations while moving the pump.

Use only lifting devices appropriated to the pump weight. Check name plate. Do not use other pump elements than the lifting lugs as handles.

1.7.2 Storage

Before stocking the pump for a long time put it back in its original condition (blank off inlet and exhaust ports with the shipping seals, drain the oil sump) and store the pump in a dry place at room temperature. A storage period exceeding one year requires a pump maintenance. Please contact Leybold customer service.

Storage temp. : - 15°C to + 60°C.

1.8 Lubricants

The SOGEVAC® SV28 BI pumps should be run with mineral oils for vacuum pumps with low viscosity according to ISO category VG32. The Leybold oil corresponds to these prescriptions.

LVO120 Oil

Conditioning	Reference
1l	711 17 772 / L12001
2l	711 17 723 / L12002
5l	711 17 724 / L12005
20l	711 17 725 / L12020

You may use other special lubricants adapted to the applications. Please consult us.

2 Installation (see chapter 1.1)

It is essential to observe the following instructions step by step to ensure safe start-up. Start-up may only be conducted by trained specialists.

2.1 Setting-up

The pump must be set up or mounted horizontally on a flat surface. Special mounting is not required.

The following ambient operating environment must be observed :

- . Ambient temperature: 15°C to 40°C (59°F to 104°F),
- . Ambient pressure = Atmospheric pressure.

In order to avoid over-heating of the pump, an undisturbed fresh airflow to the pump is necessary.

The pump must be kept clean (no dust deposit)

Warning



2.2 Inlet connection (see chapter 1.1)

The inlet flange can be connected with a vacuum-tight flexible hose and/or pipe. The pipes should cause no stresses on the pump's flanges. If necessary, compensators must be installed.

Restriction of the pipes must be avoided in order not to decrease the pumping speed of the pump. The nominal diameter of the pipes has to be at least the same as the diameter of pump inlet flange.

When removing condensable vapours, a gas ballast valve must be installed or open.

The inlet pressure must not be above atm. pressure.

2.3 Connection to exhaust side

No isolation or restricting devices should be installed in the exhaust line of the pump. If an exhaust line is installed, it must at least have the same diameter as the exhaust flange. It should be installed in a manner so that no condensate can enter the pump (siphon, slope).

Pump exhaust to be connected if oil mist or process gases are to be avoided in the pump area.

Warning: The maximum exhaust pressure must neither exceed 1.15 bar absolute (0.15 bar relative), nor fall under atmospheric pressure minus 15 mbar.

Corresponding pressure regulating devices to be installed by the user.

2.4 Oil filling (see chapter 1.1.4)

The necessary oil is supplied in a can beside the pump. To fill in the oil, unscrew the oil fill plug and fill in until the oil level reaches the "MAX" mark beside the oil sight glass.

Warning



2.5. Electrical connection (see chapters 1.1.4 and 1.1.5)

The electrical installation may only be conducted by a specialist. Local regulations have to be followed. Disconnect the power supply before any work in the motor connection box !

. Voltage and frequency mentioned on the motor nameplate must correspond to the supply voltage and frequency.

. The drive motor must be protected against overloads according to local regulations and IEC 60204-1 & IEC 61010-1

2.5.1 Single phase motors

Single phase motors are equipped with a C14 or C20 socket (depending of their rated voltage) and a C13 or C19 plug for user's mains cord. The motor integrates a motor over-load protection device (red knob on motor connection box) to be manually reset after an overload trip, and an ON/OFF switch. The power socket and cord are disconnection elements which must remain accessible to the users.

2.5.2 Three phase motors

A motor protection breaker is to be used to protect the motor against over-currents. The breaker tripping current must be set in accordance with the rated current marked on the motor nameplate. To check the direction of rotation of pumps, flick pump on. If the direction of rotation is not identical to the one indicated by the arrow sticking on the motor hood, then inverse any two of the 3 electrical phases in the terminal box. Looking at the motor fan cover, the direction of rotation has to be counter-clockwise.

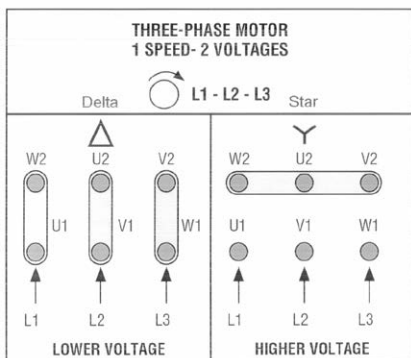

3-phase connection diagram

2.6 Operating advices (See chapters 1.1.1, 1.1.2, 1.1.3 and 1.2)

When removing condensable vapours, a gas ballast valve must be installed or opened.

The vacuum pump must be run for 30 minutes prior to operation with the inlet connection closed, in order to reach the operating temperature of about 75°C. Only up from this operating temperature, condensable vapours can be transported. After use, the pump has to be left running for an additional 30 minutes with the inlet connection closed and open gas ballast, to clear the oil of condensate.

Use ear protection in case of operation at high inlet pressures

2.7 Shutdown

The inlet flange of the SOGEVAC® pumps contains an anti-suck back valve. It closes the inlet flange when the pump is voluntarily or accidentally shut down, thus maintaining the vacuum in the connected system and preventing oil from being sucked back into the system.

Except the indications in chapter 2.6 (operating advices) there are no particular precautions for the shutdown of the pump.

If the pump must be stopped for a longer period, see chapter 1.7.

Close the gas ballast

Warning



3 Maintenance (see chapter 1.1)

The vacuum pump must be switched off and secured against accidental switch-on for all maintenance jobs. All work must be done by suitably trained personnel.

The following maintenance-schedule shows the regular maintenance periods for an average use of the pump.

Unfavourable ambient conditions and/or aggressive media may significantly reduce the maintenance intervals.

On the other hand, favorable conditions may allow longer operating periods or to skip the first oil change.

Maintenance job	Frequency	Section
Check the oil level	daily	3.1
Subsequent oil changes	Every 2000 h of operation or 6 months (depending on application)	3.2
Replace the exhaust filter	If oil mist at exhaust or annually	3.3
Gas ballast valve	Monthly	3.4
Clean the inlet flange sifter	6 months	3.5
Check the anti-suckback valve	6 months	3.6
Clean the fan cover	6 months	3.7
Check the electrical connection (only by a specialist)	6 months	
Generator overhaul	3 years	

To simplify the maintenance work we recommend combining several jobs. Use only Leybold spare & consumables.

After maintenance operations, make sure the device is in a safe condition before putting back into operation.

3.1 Oil level

The oil level shall be checked at least once a day and must be, while the pump is in operation, close to the MAX mark. Should the oil level be below the MIN mark switch off the pump, check it (see chapter 4) and add the required amount of oil.

3.2 Oil change

Oil changes, depending on operating conditions (products, vapours, ambient temperature...) must be done every 500 to 2000 operating hours or at least every 6 months.

If there is considerable pollution, it could be necessary to change the oil more frequently. Special oils allow to extend the oil changing period.

Oil changing must be done with a switched off and still warm pump. Open the oil drain plug and let run out the used oil into an appropriate container. Refasten the oil drain plug when oil runs slower, start up the pump briefly (5 sec. max) and switch off immediately. Re-open the oil drain plug and drain the rest of the oil.

Before refastening the oil drain plug, control the O-ring and if necessary replace it. Open the oil fill plug and pour in clean oil ; refasten the oil fill plug. The pump has to be rinsed out if there is considerable pollution. Therefore pour in clean oil up to the low edge of the oil-level glass, let the pump run briefly (for a few minutes) then drain the oil again.

3.3 Exhaust filters replacement (see chapters 1.1.6 and 1.1.8)

Oil mist escaping from the exhaust during operation indicates that the filter is probably clogged. Increased energy intake by the motor could also be the result of a soiled exhaust filter. Open the exhaust hood, take out the filter and replace it. Also check the gasket of the exhaust flange and change it if necessary.

3.4 Gas ballast valve cleaning (see safety prescriptions chapter)

Consult Leybold

3.5 Inlet flange sifter cleaning

See safety prescriptions chapters 1.1.2., 1.1.6. and 1.1.8.

To clean the inlet flange sifter, disconnect the inlet connection and clean the sifter with blast air or an appropriate solvent.

3.6 Anti-suck back valve checking

See safety prescriptions chapters 1.1.2., 1.1.6. and 1.1.8.

The anti-suck back valve should be checked at the same time as the inlet flange sifter and if dirty, be cleaned with an appropriate solvent. Remove the inlet flange, check if there is no damage on the sealing part of the valve.

3.7 Fan cover cleaning

Soiling of the fan cover may lead to overheating of the motor and the pump. Put off the cover and clean it with blast air. Before starting the pump again, be sure that the cover has been reassembled.

3.8 Checking the float valve (see chapters 1.1.6 and 1.1.8)

When replacing the exhaust filter, check the cleanliness and the proper operation of the float valve. After having disassembled the exhaust flange and fan cover, remove the screw using a 4mm Allen Key. Pull on the float valve, clean the nozzle and check that the float itself oscillates free around its axle and that the valve is tight. Clean the float chamber of the oil casing. Reassemble in the reverse sequence.

4 Breakdown analysis

If you have a breakdown, please contact the Leybold service station and/or ask us, to send you the guide: "breakdown analysis".

Spare parts

5 Spare parts

To guarantee safe operation of the Leybold vacuum pump, only original spare parts and accessories should be used. When ordering spare parts and accessories, always state pump type and serial number. You can find part numbers in the spare parts list.

Consumables and main spare parts kits for SOGEVAC® pumps are usually available on stock at Leybold's service centers. The list of these parts is given hereafter and in the spare part table where the contents of each kit is detailed.

- . Exhaust demisters
- . Oil (Special oils please refer to the specific notice of the pump or contact Leybold).
- . Service kit
- . Set of seals
- . Repair kit

We recommend to use these kits which have been defined to allow an optimal maintenance or repair. Individual spare parts may need longer delivery time.

Return to Leybold service station

If the pump has to be returned to Leybold service station for repairing, you have to attach the form "Declaration of Contamination of Vacuum Equipment and Components".

The Service of Leybold will send it to you on simple request (specimen on the end of this manual).

Leybold will return to the sender's address any material received without this declaration.

For the transport, the pump and its components must be packaged in such a way, that it will not be damaged during shipping, and that no harmful substances can escape from the package.

6 Information

We would be happy to supply further information as required:

Available are :

- . Technical description of the SOGEVAC® vacuum pumps
- . Technical description of special oil types for vacuum pumps
- . Declaration of Contamination of Vacuum Equipment and Components.

EU Declaration of Conformity

(Translation of original Declaration of Conformity)

The manufacturer: Leybold GmbH
Bonner Strasse 498
D-50968 Köln
Germany

herewith declares that the products specified and listed below which we have placed on the market, comply with the applicable EU Council Directives. This declaration becomes invalid if modifications are made to the product without agreement of Leybold GmbH.

Product designation: SOGEVAC

Type designation: SV16, SV25, SV16D, SV25D, SV200, SV1200, SV16B, SV25B, SV40B, SV65B, SV100B, SV120B (I FC), SV300B, SV470B, SV500B, SV570B, SV630B, SV750B, SV28BI (FC), SV40BI (FC), SV65BI (FC), and their variants, excepted pumps delivered without motor

The products complies to the following European Council Directives:

Machinery Directive (2006/42/EC)

The safety objectives of the Low Voltage Directive 2014/35/EU were complied with in accordance with Appendix 1 No. 1.5.1 of Machinery Directive 2006/42/EC.

Electromagnetic Compatibility (2014/30/EU)

RoHS Directive (2011/65/EU) & (2015/863/EU)

The following harmonized standards have been applied:

EN 1012-2:1996+A1:2009	Compressors and vacuum pumps — Safety requirements — Part 2: Vacuum pumps
EN 60204-1:2006/A1:2009	Safety of machinery — Electrical equipment of machines — Part 1: General requirements requirements
EN 61000-6-2:2005/AC:2005	Electromagnetic compatibility (EMC) - Part 6-2: Generic standards - Immunity for industrial environments
EN 61000-6-4:2007/A1:2011	Electromagnetic compatibility (EMC) - Part 6-4: Generic standards - Emission standard for industrial environments

Documentation officer: Herbert Etges
T: +49(0)221 347 0
F: +49(0)221 347 1250
documentation@leybold.com

Cologne, November 14, 2016

Cologne, November 14, 2016



ppa. Martin Tollner
Head of Product Lines



ppa. Dr. Monika Mattern-Klosson
Head of Quality & Business Process Management

Declaration of contamination



Declaration of Contamination of Compressors, Vacuum Pumps and Components

The repair and / or servicing of compressors, vacuum pumps and components will be carried out only if a correctly completed declaration has been submitted. Non-completion will result in delay. The manufacturer can refuse to accept any equipment without a declaration.

A separate declaration has to be completed for each single component.

This declaration may be completed and signed only by authorized and qualified staff.

Customer/Dep./Institute : _____ Address : _____ _____ Person to contact: _____ Phone : _____ Fax: _____ End user: _____	Reason for return: <input checked="" type="checkbox"/> applicable please mark Repair: <input type="checkbox"/> chargeable <input type="checkbox"/> warranty Exchange: <input type="checkbox"/> chargeable <input type="checkbox"/> warranty <input type="checkbox"/> Exchange already arranged / received Return only: <input type="checkbox"/> rent <input type="checkbox"/> loan <input type="checkbox"/> for credit Calibration: <input type="checkbox"/> DKD <input type="checkbox"/> Factory-calibr. <input type="checkbox"/> Quality test certificate DIN 55350-18-4.2.1
----------------------------------------------------------------------------------------------------------------------------------------	------------------------------------------------------------------------------------------------------------------------------------------------------------------------------------------------------------------------------------------------------------------------------------------------------------------------------------------------------------------------------------------------------------------------------------------------------------------------------------------------------------------------------------------------------------------------------------------------------------------------------

A. Description of the Leybold product: Material description : _____ Catalog number: _____ Serial number: _____ Type of oil (ForeVacuum-Pumps) : _____	Failure description: _____ Additional parts: _____ Application-Tool: _____ Application- Process: _____
--------------------------------------------------------------------------------------------------------------------------------------------------------------------------	---------------------------------------------------------------------------------------------------------------------------------------------

B. Condition of the equipment	No ¹⁾	Yes	No	Contamination :	No ¹⁾	Yes
1. Has the equipment been used	<input type="checkbox"/>	<input type="checkbox"/>	<input checked="" type="checkbox"/>	toxic	<input type="checkbox"/>	<input type="checkbox"/>
2. Drained (Product/service fluid)	<input checked="" type="checkbox"/>	<input type="checkbox"/>	<input type="checkbox"/>	corrosive	<input type="checkbox"/>	<input type="checkbox"/>
3. All openings sealed airtight	<input checked="" type="checkbox"/>	<input type="checkbox"/>	<input type="checkbox"/>	flammable	<input type="checkbox"/>	<input type="checkbox"/>
4. Purged	<input type="checkbox"/>	<input type="checkbox"/>	<input type="checkbox"/>	explosive ²⁾	<input type="checkbox"/>	<input type="checkbox"/>
If yes, which cleaning agent				radioactive ²⁾	<input type="checkbox"/>	<input type="checkbox"/>
and which method of cleaning				microbiological ²⁾	<input type="checkbox"/>	<input type="checkbox"/>
¹⁾ If answered with "No", go to D.				other harmful substances	<input type="checkbox"/>	<input type="checkbox"/>

C. Description of processed substances (Please fill in absolutely)

1. **What substances have come into contact with the equipment ?**
 Trade name and / or chemical term of service fluids and substances processed, properties of the substances
 According to safety data sheet (e.g. toxic, inflammable, corrosive, radioactive)

X	Tradename:	Chemical name:
	a)	
	b)	
	c)	
	d)	

	No	Yes
2. Are these substances harmful ?	<input type="checkbox"/>	<input type="checkbox"/>
3. Dangerous decomposition products when heated ?	<input type="checkbox"/>	<input type="checkbox"/>
If yes, which ? _____		

²⁾ Components contaminated by microbiological, explosive or radioactive products/substances will not be accepted without written evidence of decontamination.

D. Legally binding declaration

I / we hereby declare that the information supplied on this form is accurate and sufficient to judge any contamination level.

Name of authorized person (block letters) : _____

Date

signature of authorized person

firm stamp

Spare parts list

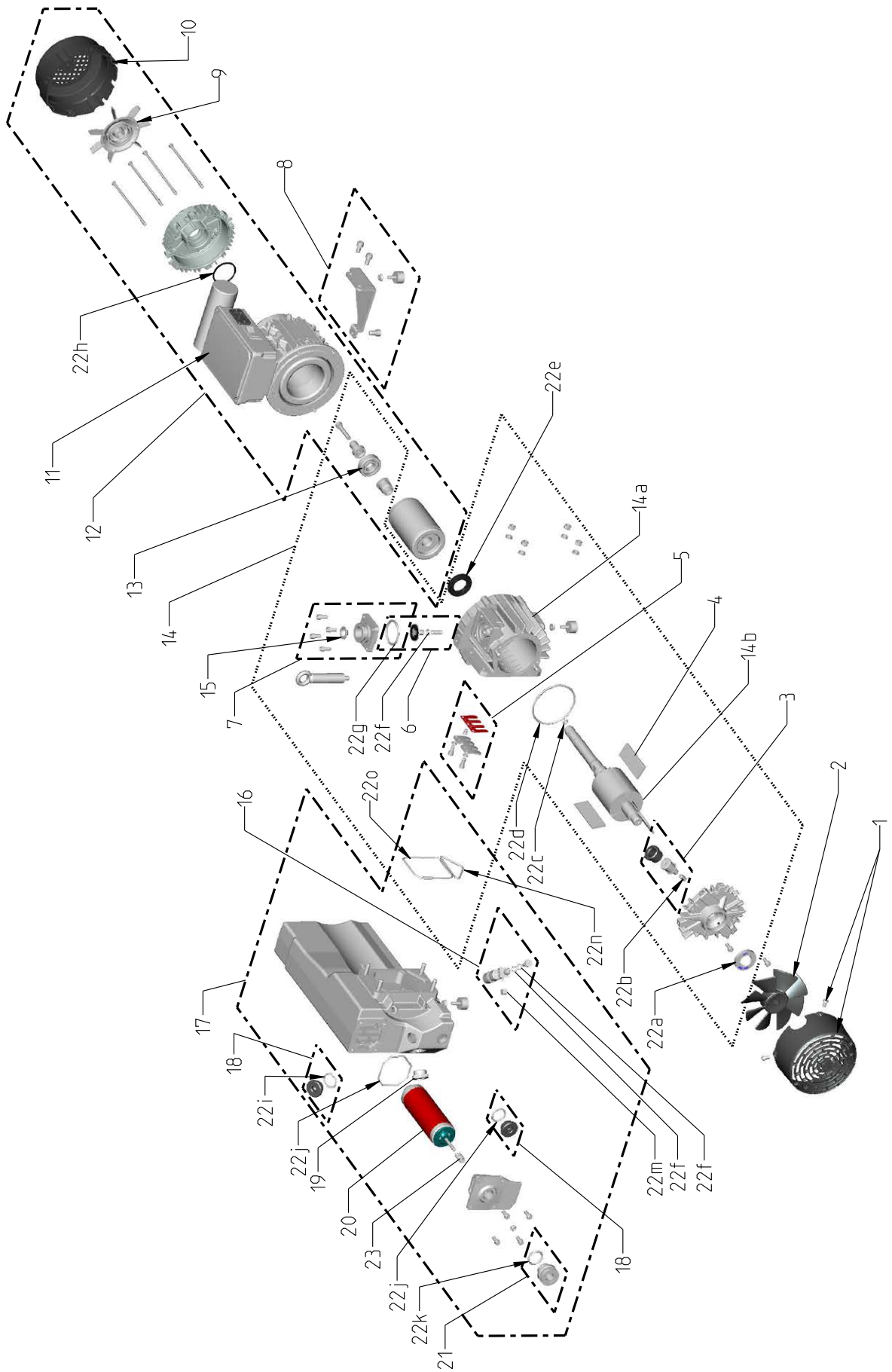

Spare parts list

Pos.	Stück. Qty Qté	BENENNUNG	SPECIFICATION	DESIGNATION	Werkstoff Material Matériau	Bestell-Nr Ref. No, N° de réf.	Bemerkungen Notes Remarques
1	1	TURBINENHAUBE	FAN COVER	CAPOT TURBINE ENS.		971447860	
2	1	TURBINE	FAN	TURBINE		971447870	
3	1	GAS BALLAST KIT	GAS BALLAST KIT	KIT LEST AIR		971462640	
4	1	SCHIEBERSATZ 3 STÜCK	SET OF 3 VANES	JEU DE 3 PALETTES		971447220	
5	1	VENTILPLATTE UND ANSCHLAG KIT	VALVE AND VALVE STOP KIT	KIT LAME ET CONTRE LAME		971462750	
6	1	SAUGSTUTZEN KIT	ANTI SUCK BACK KIT	KIT CLAPET ASPIRATION		971462600	Incl. 22f, 22g
7	1	ANSAUGFLANSCH KIT	INTAKE FLANGE KIT	KIT BRIDE ASPI		971454300	Incl. 15, 22g
8	1	GUMMIFUSS KIT	RUBBER FEET KIT	KIT AMORTISSEURS		971462650	
9	1	MOTOR LUEFTER	MOTOR FAN	VENTILATEUR MOTEUR			auf Anfrage / upon request /
10	1	MOTOR LUEFTERHAUBE	MOTOR FAN COVER	CAPOT MOTEUR			
11	1	KONDENSATOREN 1 PH 115 V	CAPACITORS 1 PH 115 V	CONDENSATEURS MONO 115 V			
12	1	DREHSTROM MOTOR	THREE PHASE MOTOR	MOTEUR TRI		971457650	
12	1	WECHSELSTROM MOTOR 200...240 V ±10%	SINGLE PHASE MOTOR 200...240 V ±10%	MOTEUR MONO 200...240 V ±10%		EK6510658	180...264 V, 50 & 60 Hz
12	1	WECHSELSTROM MOTOR 115 V	SINGLE PHASE MOTOR 115 V	MOTEUR MONO 115V		971457680	
13	1	DREHSTROM MOTOR KUGELLAGER	BEARING THREE PHASE MOTOR	ROULEMENT MOTEUR TRI		971464740	
13	1	WECHSELSTROM MOTOR KUGELLAGER	BEARING SINGLE PHASE MOTOR	ROULEMENT MOTEUR MONO		971440330	
14	1	GENERATOR MODUL DREHSTROM	GENERATOR THREE PHASE	GENERATEUR ENS. TRI		971462620	Incl. 22a,b,c,d,e,f,g,n,o
14	1	GENERATOR MODUL WECHSELSTROM (180-264 V)	GENERATOR SINGLE PHASE (consult Leybold for 115 V version)	GENERATEUR ENS. MONO (180-264 V)		971462630	Incl. 22a,b,c,d,e,f,g,n,o
14a	1	STATOR	STATOR	STATOR		EK6511398	
14b	1	ROTOR WECHSELSTROM	ROTOR SINGLE PHASE	ROTOR MONOPHASE		EK6512396	
14b	1	ROTOR DREHSTROM	ROTOR THREE PHASES	ROTOR TRIPHASE		EK971459221	
15	1	EINLASS FILTER	INLET FILTER	FILTRE ASPIRATION		71413440	
16	1	SCHWIMMVENTIL	FLOAT VALVE	FLOTTEUR ENS.		971462660	Incl. 22f, 22m
17	1	OELKASTEN 0.5 L	OIL CASING 0.5 L	CARTER 0.5L ENS.		971449400	Incl. 16, 18, 19, 20, 21, 22, n, o, 23
17	1	OELKASTEN 1.5 L	OIL CASING 1.5 L	CARTER 1.5L ENS.		971454140	Incl. 16, 18, 19, 20, 21, 22, n, o, 23
18	1	STOPFEN G 3/4	PLUG G 3/4	BOUCHON G 3/4		71256380	Incl. 22i
19	1	OELSCHAUGGLASS	OIL SIGHT GLASS	VOYANT HUILE		71212420	
20	1	AUSLASSFILTER	EXHAUST FILTER	CARTOUCHE REFOUL. AVEC BY-PASS		71416340	
21	1	AUSLASS 25 KF ANSCHLUSS	EXHAUST 25 KF FITTING	RACCORD 25KF		71404530	Incl. 22k
22		DICHTUNGS KIT	KIT OF SEALS	JEU DE JOINTS	FKM	971462670	All 22
		REPARATUR KIT	REPAIR KIT	KIT REPARATION		971462690	Incl. 4, 5, 19, 20, 22, 23
		WARTUNGS KIT	MAINTENANCE KIT	KIT DE MAINTENANCE		971462810	Incl. 18, 20, 22k, 23

Sales and Service

Germany

Leybold GmbH

Sales, Service, Support Center (3SC)
Bonner Strasse 498
D-50968 Cologne
T: +49-(0)221-347 1234
F: +49-(0)221-347 31234
sales@leybold.com
www.leybold.com

Leybold GmbH Sales Area North

Branch Office Berlin
Industriestrasse 10b
D-12099 Berlin
T: +49-(0)30-435 609 0
F: +49-(0)30-435 609 10
sales.bn@leybold.com

Leybold GmbH Sales Office South

Branch Office Munich
Karl-Hammerschmidt-Strasse 34
D-85609 Aschheim-Dornach
T: +49-(0)89-357 33 9-10
F: +49-(0)89-357 33 9-33
sales.mn@leybold.com
service.mn@leybold.com

Leybold Dresden GmbH Service Competence Center

Zur Wetterwarte 50, Haus 304
D-01109 Dresden
Service:
T: +49-(0)351-88 55 00
F: +49-(0)351-88 55 041
info.dr@leybold.com

Europe

Belgium

Leybold Nederland B.V. Belgisch bijkantoor

Leuvensesteenweg 542-9A
B-1930 Zaventem
Sales:
T: +32-2-711 00 83
F: +32-2-720 83 38
sales.zv@leybold.com
Service:
T: +32-2-711 00 82
F: +32-2-720 83 38
service.zv@leybold.com

France

Leybold France S.A.S.

Parc du Technopolis, Bâtiment Beta
3, Avenue du Canada
F-91940 Les Ulis cedex
Sales and Service:
T: +33-1-69 82 48 00
F: +33-1-69 07 57 38
info.ctb@leybold.com
sales.ctb@leybold.com

Leybold France S.A.S.

Valence Factory
640, Rue A. Bergès
B.P. 107
F-26501 Bourg-lès-Valence Cedex
T: +33-4-75 82 33 00
F: +33-4-75 82 92 69
marketing.vc@leybold.com

Great Britain

Leybold UK LTD.

Unit 9
Silverglade Business Park
Leatherhead Road
Chessington
Surrey (London)
KT9 2QL
Sales:
T: +44-13-7273 7300
F: +44-13-7273 7301
sales.ln@leybold.com
Service:
T: +44-13-7273 7320
F: +44-13-7273 7303
service.ln@leybold.com

Italy

Leybold Italia S.r.l.

Via Trasimeno 8
I-20128 Mailand
Sales:
T: +39-02-27 22 31
F: +39-02-27 20 96 41
sales.mi@leybold.com
Service:
T: +39-02-27 22 31
F: +39-02-27 22 32 17
service.mi@leybold.com

Netherlands

Leybold Nederland B.V.

Floridadreef 102
NL-3565 AM Utrecht
Sales and Service:
T: +31-(30) 242 63 30
F: +31-(30) 242 63 31
sales.ut@leybold.com
service.ut@leybold.com

Switzerland

Leybold Schweiz AG, Pfäffikon

Churerstrasse 120
CH-8808 Pfäffikon
Warehouse and shipping address:
Riedthofstrasse 214
CH-8105 Regensdorf
Sales:
T: +41-44-308 40 50
F: +41-44-302 43 73
sales.zh@leybold.com
Service:
T: +41-44-308 40 62
F: +41-44-308 40 60
service.zh@leybold.com

Spain

Leybold Spain, S.A.

C/. Huelva, 7
E-08940 Cornellà de Llobregat
(Barcelona)
Sales:
T: +34-93-666 43 11
F: +34-93-666 43 70
sales.ba@leybold.com
Service:
T: +34-93-666 46 11
F: +34-93-685 43 70
service.ba@leybold.com

America

USA

Leybold USA Inc.

5700 Mellon Road
USA-Export, PA 15632
T: +1-724-327-5700
F: +1-724-325-3577
info.ex@leybold.com
Sales:
T: +1-724-327-5700
F: +1-724-333-1217
Service:
T: +1-724-327-5700
F: +1-724-325-3577

Brazil

Leybold do Brasil

Rod. Vice-Prefeito Hermenegildo Tonolli,
nº. 4413 - 6B
Distrito Industrial
Jundiá - SP
CEP 13.213-086
Sales and Service:
T: +55 11 3395 3180
F: +55 11 99467 5934
sales.ju@leybold.com
service.ju@leybold.com

Asia

P. R. China

Leybold (Tianjin) International Trade Co. Ltd.

Beichen Economic
Development Area (BEDA),
No. 8 Western Shuangchen Road
Tianjin 300400
China
Sales and Service:
T: +86-22-2697 0808
F: +86-22-2697 4061
F: +86-22-2697 2017
sales.tj@leybold.com
service.tj@leybold.com

India

Leybold India Pvt Ltd.

No. 82(P), 4th Phase
K.I.A.D.B. Plot
Bommasandra Industrial Area
Bangalore - 560 099
Indien
Sales and Service:
T: +91-80-2783 9925
F: +91-80-2783 9926
sales.bgl@leybold.com
service.bgl@leybold.com

Japan

Leybold Japan Co., Ltd.

Headquarters
Shin-Yokohama A.K.Bldg., 4th floor
3-23-3, Shin-Yokohama
Kohoku-ku, Yokohama-shi
Kanawaga 222-0033
Japan
Sales:
T: +81-45-471-3330
F: +81-45-471-3323
sales.yh@leybold.com

Leybold Japan Co., Ltd.

Tsukuba Technical Service Center
1959, Kami-yokoba
Tsukuba-shi, Ibaraki-shi 305-0854
Japan
Service:
T: +81-29 839 5480
F: +81-29 839 5485
service.iik@leybold.com

Malaysia

Leybold Malaysia Leybold Singapore Pte Ltd.

No. 1 Jalan Hi-Tech 2/6
Kulim Hi-Tech Park
Kulim, Kedah Darul
Aman 09000
Malaysia
Sales and Service:
T: +604 4020 222
F: +604 4020 221
sales.ku@leybold.com
service.ku@leybold.com

South Korea

Leybold Korea Ltd.

3F. Jellzone 2 Tower
Jeongja-dong 159-4
Bundang-gu Sungnam-si
Gyeonggi-do
Bundang 463-384, Korea
Sales:
T: +82-31 785 1367
F: +82-31 785 1359
sales.bd@leybold.com
Service:
623-7, Upsung-Dong
Cheonan-Si
Chungcheongnam-Do
Korea 330-290
T: +82-41 589 3035
F: +82-41 588 0166
service.cn@leybold.com

Singapore

Leybold Singapore Pte Ltd.

8 Commonwealth Lane #01-01
Singapore 149555
Singapore
Sales and Service:
T: +65-6303 7030
F: +65-6773 0039
sales.sg@leybold.com
service.sg@leybold.com

Taiwan

Leybold Taiwan Ltd.

No 416-1, Sec. 3
Chunghsin Rd., Chutung
Hsinchu County 310
Taiwan, R.O.C.
Sales and Service:
T: +886-3-500 1688
F: +886-3-583 3999
sales.hc@leybold.com
service.hc@leybold.com

Headquarter

Leybold GmbH

Bonner Strasse 498
D-50968 Cologne
T: +49-(0)221-347-0
F: +49-(0)221-347-1250
info@leybold.com



www.leybold.com