

Agilent TwisTorr 404 FS



The new generation Turbo Pump with Agilent Floating Suspension

The Agilent TwisTorr 404 FS turbomolecular high-vacuum pump combines TwisTorr drag stage technology and Agilent Floating Suspension to provide high performance, reliability, and economy.

TwisTorr drag stages create high compression ratios for light gases such as hydrogen and helium to deliver high throughput and high tolerance of foreline pressure, thereby permitting the use of smaller and more economical backing pumps. This technology results in a compact rotor design that is energy-efficient and maintains a low operating temperature.

The Agilent Floating Suspension system reduces noise and vibration, and ensures optimal bearing operating conditions to extend operating life, minimize system downtime, and assure stability over time.

The unique TwisTorr 404 FS bearing and dry lubrication eliminate oil and maintenance needs, and permit operation of the pump in any orientation.

The pump can be water cooled or air cooled: in the first case the customer can use the dedicated channels on the pump body, in the second case an external optional fan is available. A thermistor sensor is mounted near the upper bearing to prevent the pump from overheating.

Technical Specifications

Technical Specifications		
Pumping speed	ISO 100K / ISO 100F / CFF 6"	
N ₂	380 L/s	
He	505 L/s	
H ₂	415 L/s	
Ar	340 L/s	
Max Gas Throughput (*)	Air Cooling (25°C ambient temperature)	Water Cooling (15 °C water temperature / 25 °C ambient temperature)
N ₂	4.3 mbar L/s 255 SCCM	6.2 mbar L/s 367 SCCM
He	7.9 mbar L/s 467 SCCM	10.4 mbar L/s 615 SCCM
Ar	1.5 mbar L/s 89 SCCM	3.3 mbar L/s 195 SCCM
(*) Backing pump 11.6 m ³ /h		
Compression ratio and foreline tolerance (**)		
N ₂	> 1 x 10 ¹¹	10 mbar
He	2 x 10 ⁸	10 mbar
H ₂	3 x 10 ⁶	> 4 mbar
Ar	> 1 x 10 ¹¹	8.5 mbar
(**) Foreline Tolerance defined as the pressure at which the turbopump still produce a compression of 100 and estimated in water cooling mode		
Base pressure with recommended forepump	< 1 x 10 ⁻¹⁰ mbar (< 1 x 10 ⁻¹⁰ Torr)	
Inlet flange	ISO 100K, ISO 100F, CFF 6"	
Foreline flange	NW25 (NW16 as optional accessory)	
Rotational speed	Auto setting from 40800 RPM to 49500 RPM	
Start-up time	< 5 minutes	

Technical Specifications		
Recommended forepump	Agilent DS302 Rotary Vane Pump Agilent IDP-10 Dry Scroll Pump Agilent IDP-15 Dry Scroll Pump	
Operating position	Any	
Oper. ambient temperature	+5 °C to +35 °C	
Relative humidity of air	0 to 90% (not condensing)	
Bakeout temperature	ISO pump: 80°C at inlet flange CFF pump: 120°C at inlet flange	
Lubricant	Permanent lubrication	
Cooling requirements		
Air cooling	Air temperature from +5°C to 35°C	
Water cooling	Water temperature from +15°C to +25°C Water flow min. 100L/h	
Noise Pressure Level (at 1m at full speed)	43dB(A)	
Storage temperature	-40 °C to +70 °C	
Max altitude	3000 m	
Weight kg (lbs)	ISO100K	22.6 kg (49.8)
	ISO100F	23.7 kg (52.3)
	CFF 6"	23.5 kg (51.8)

Conformity to norms	
EMC (Control Units)	61326-1
Safety (CE/CSA)	61010-1
Machinery Directive	DIR 2006/42/CE
Low Voltage Directive	DIR 2014/35/EU
EMC Directive (Control Units)	DIR 2014/30/EU
ROHS	DIR 2011/65/EU

Outline Drawings

Dimensions: millimeters (inches)

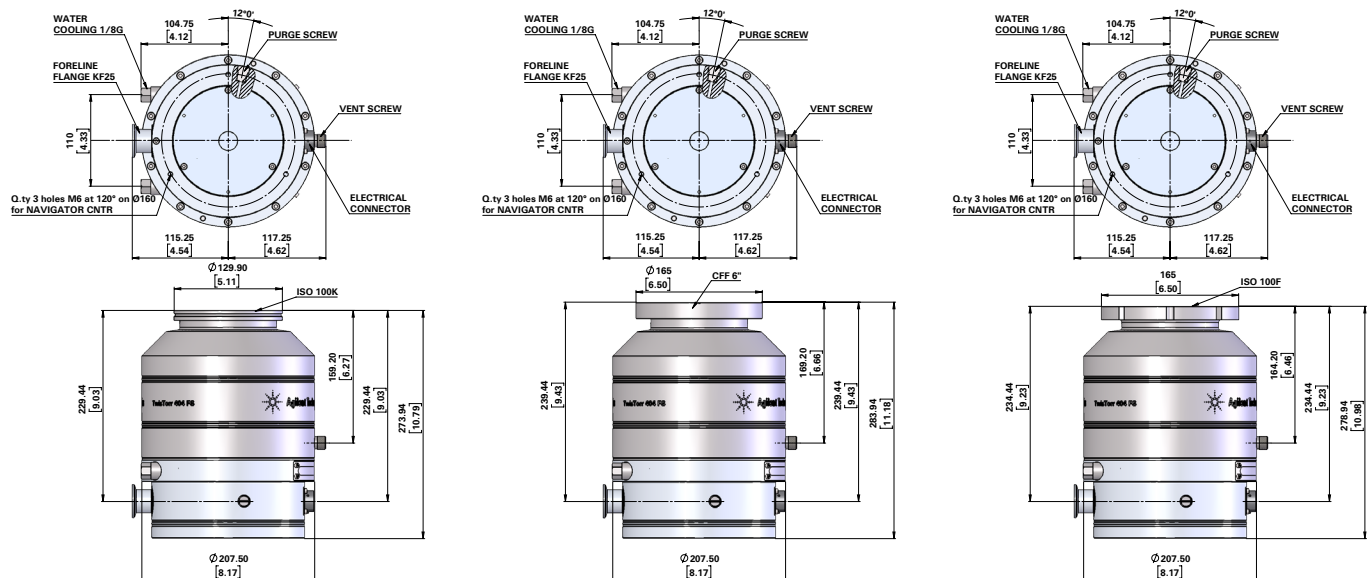

Ordering Information

Pumps	Configuration Options
TwisTorr 404 FS ISO100K KF25	X3511-64019
TwisTorr 404 FS ISO100F KF25	X3511-64020
TwisTorr 404 FS CFF6" KF25	X3511-64021
Controllers	Part Numbers
TwisTorr Medium-TMP Rack Controller	X3501-64016
TwisTorr Medium-TMP Onboard Controller	X3512-64016
Cables	Part Numbers
Mains cable NEMA plug 3 m long	9699958
Mains cable EU plug 3 m long	9699957
Mains cable UK plug 2.5 m long	X3501-68005
Serial Cable & A-PLUS Software	9699883
Medium-TMP Extension Cable	9699948M001 (5 m) 9699948M003 (10 m) 9699948M004 (15 m) 9699948M002 (20 m) 9699948M005 (30 m) 9699948M006 (50 m) 9699948M009 (75 m) 9699948M010 (100 m)
Inlet Screen	Part Numbers
Inlet Screen ISO100/CFF6	9699302
Cooling	Part Numbers
Medium-TMP Air Cooling Kit for Rack Controller	X3501-68001
Medium-TMP Air Cooling Kit for on board Controller	9699297
Plastic Water cooling Kit	9699347
Metal Water cooling Kit	9699337
Air Cooling Kit Extension Cable 5m	X3501-68101
Air Cooling Kit Extension Cable 10m	X3501-68051
Air Cooling Kit Extension Cable 15m	X3501-68061
Air Cooling Kit Extension Cable 20m	X3501-68021
Air Cooling Kit Extension Cable 30m	X3501-68011
Air Cooling Kit Extension Cable 50m	X3501-68071
Air Cooling Kit Extension Cable 75m	X3501-68081

Venting	Part Numbers
Vent valve driven by Rack Controller, N.O., 1.2 mm orifice	X3501-68002
Vent valve driven by Onboard Controller, N.O., 1.2 mm orifice	9699834
Vent valve driven by Rack Controller, N.C., 1.2 mm orifice (Minimum HW revision required: A0005 for controller PN X3501-64016)	X3501-68022
Vent valve driven by Onboard Controller, N.C., 1.2 mm orifice (Minimum HW revision required: A003. Controller factory setting: N.O. - Switch to N.C. setting to operate the N.C. valve)	9699834M010
Vent flange, NW 10 KF / M8	9699108
Vent valve Rack Extension Cable	X3501-68004 (5 m) X3501-68054 (10 m) X3501-68064 (15 m) X3501-68074 (20 m) X3501-68084 (30 m) X3501-68034 (50 m) X3501-68094 (75 m) X3501-68104 (100 m)
Purge	Part Numbers
Purge 10SCCM M12-NW16KF	9699239
Purge 10SCCM M12-1/4 Swagelok	9699240
Purge 20SCCM M12-NW16KF	9699241
Purge 20SCCM M12-1/4 Swagelok	9699242
Spare Purge Screw	X3502-68004
Mounting	Part Numbers
Medium-TMP onboard Controller side-mounting bracket	X3511-68003
Medium-TMP KF16 foreline flange	X3511-68004
Medium-TMP KF25 foreline flange	X3511-68001
Medium-TMP KF40 foreline flange	X3511-68002

Compression Ratio

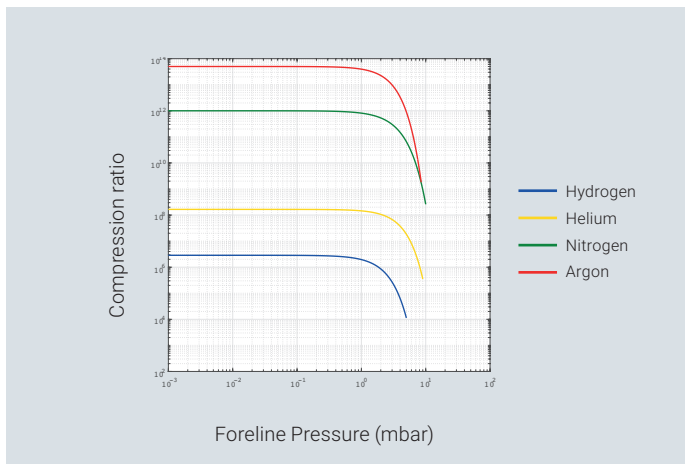

Pumping Speed

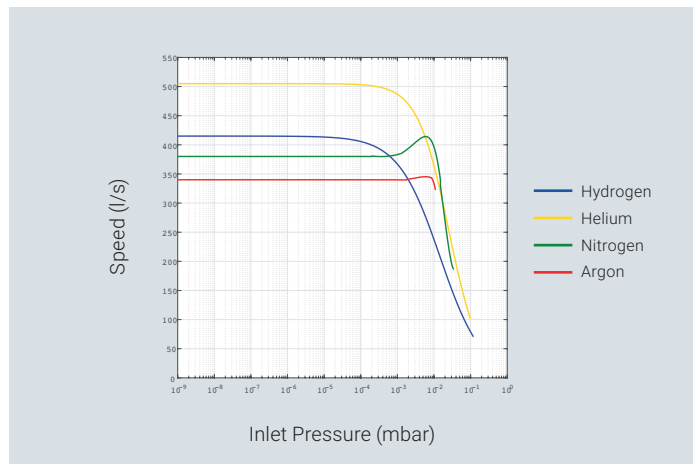

Contact information

Americas

Agilent Technologies
121 Hartwell Avenue,
Lexington, MA 02421 USA
Toll free: +1 800 882 7426
vpl-customer@agilent.com

Europe, Middle East, Africa, India

Agilent Technologies Italia SpA
Via F.lli Varian 54,
10040 Leini (Torino), Italy
Tel: +39 011 9979 111
Toll free: 00 800 234 234 00
vpt-customer@agilent.com

China

Beijing Office Agilent Technologies (China) Co. Ltd.
No.3, Wang Jing Bei Lu,
Chao Yang District,
Beijing, 100102, China
Toll free: 800 820 6778
Contacts.vacuum@agilent.com

For more information, please contact
your Agilent representative or visit
www.agilent.com/chem/vacuum where
you can chat live with a vacuum expert.



<https://www.agilent.com/en/product/vacuum-technologies/turbo-pumps-controllers/turbo-pumps/twistorr-404-fs-turbo-pump>

DE44480.6169560185

This information is subject to change without notice.

© Agilent Technologies, Inc. 2021
Printed in the USA, October 18, 2021
5991-9475EN