

MPF PRODUCTS INC.

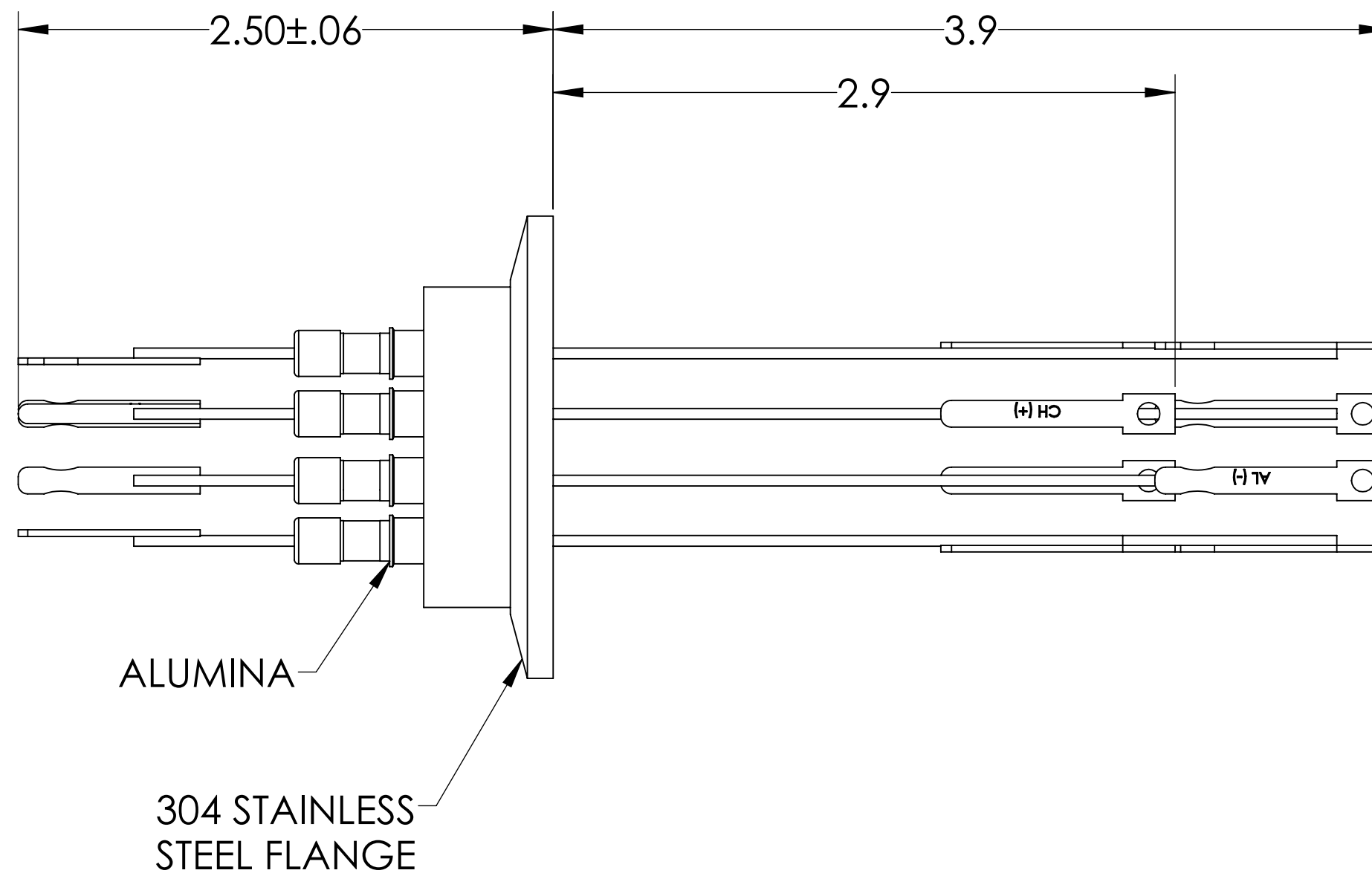

PART #	T/C TYPE
A0784-1-QF	C
A0784-2-QF	E
A0784-3-QF	J
A0784-4-QF	K

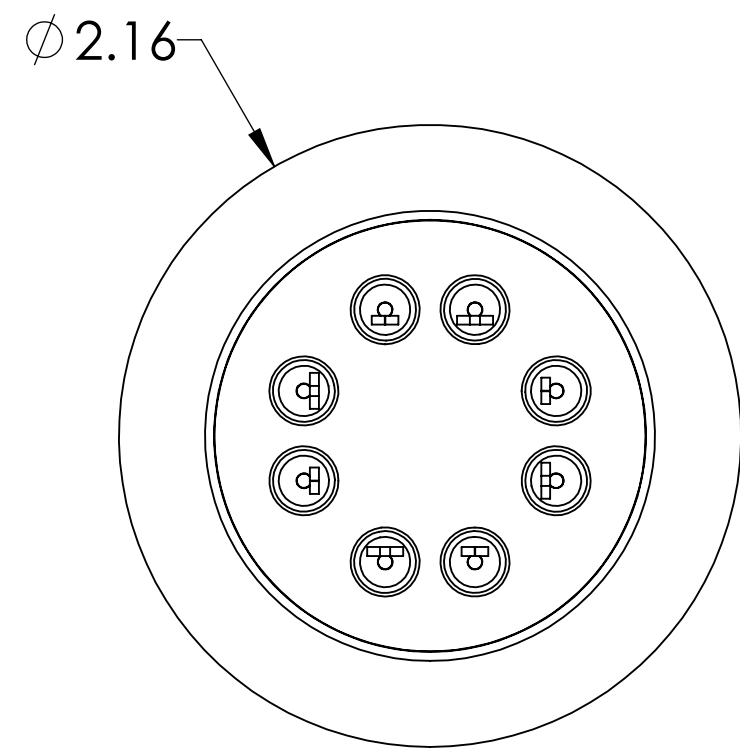
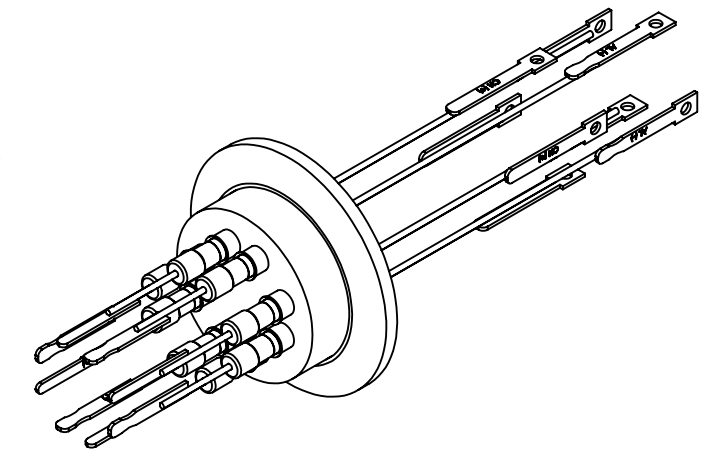
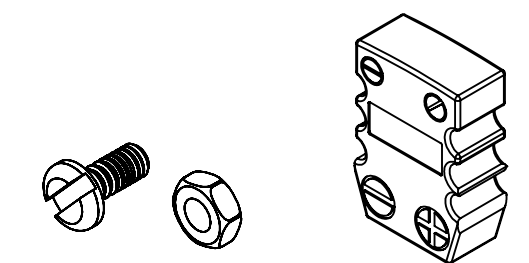

SPECIFICATIONS:

1. TEMPERATURE RATING: -100 TO 450°C
2. LEAK RATE < 1X10-9 ATM CC/SEC HE

Thermocouple Feedthrough, 4 Pairs, Miniature Connector, 2.16" QF/KF

UNLESS OTHERWISE SPECIFIED:		QUOTATION #		N/A	
DIMENSIONS ARE IN INCHES TOLERANCES:		NAME	DATE	MPF PRODUCTS INC.	
ANGULAR: MACH ± 1/2°		DRAWN	9/11/2015		
TWO PLACE DECIMAL ± .030		CHECKED	9/11/2015		
THREE PLACE DECIMAL ± .015		ENG APPR.	9/11/2015		
MATERIAL		THIRD ANGLE:		THERMOCOUPLE, 4 PAIRS, CONNECTOR, 2.16" QF/KF	
FINISH					
PLATING		APPLICATION		DOWNLOADED FROM MPFPI.COM	
		NEXT ASSY USED ON		DWG. NO.	
		SURFACE FINISH: 63/ OR BETTER		A0784	
		UNLESS OTHERWISE SPECIFIED:		REV	
		ALL DIAMETERS CONCENTRIC WITHIN .005. REMOVE ALL BURRS AND SHARP EDGES		Friday, February 8, 2019 8:28:56 AM	