

SPECIFICATION AND DATA		ES2000	ES4000	ES7500	ES300/40	
					‡ Main (high)	Auxiliary (low)
* Ultimate vacuum without gas ballast	better than (torr)	5×10^{-3}	5×10^{-3}	10^{-2}	1-0	100
** Ultimate vacuum with auxiliary gas ballast	better than (torr)	2×10^{-2}	2×10^{-2}	2×10^{-2}	-	-
** Ultimate vacuum with full gas ballast	better than (torr)	5×10^{-1}	5×10^{-1}	5×10^{-1}	-	-
Normal speed of rotation	(r.p.m.)	520	520	350	350	-
Displacement (swept volume) at normal speed of rotation	(litres/min)	2100	4200	7800	High stage	Low stage
	(m ³ /hour)	126	252	467.2	7800	1000
	(ft ³ /min)	74.3	148.6	275.5	467.2	61.4
Maximum gas ballast flow	(litres/min)	120-160	240-300	510-560	-	-
	(m ³ /hour)	7.2-9.5	14.4-18	30.5-33.9	-	-
	(ft ³ /min)	4.2-5.6	8.5-10.6	18-20	-	-
Maximum safe inlet pressure of water vapour at full gas ballast (approximate)	(torr)	Refer to page 12	-	-	-	-
Safe water vapour pumping rates	(lb/hr)	Refer to page 12	-	-	-	-
Normal running temperature without gas ballast (at 20°C ambient)	(°C)	50 to 60	50 to 60	50 to 60	50 to 60	-
	(°C)	80 to 90	80 to 90	80 to 90	70 to 80	-
Normal oil capacity	(litres)	9.1	16.1	30	30	-
	(Imp. galls)	2.0	3.5	7	7	-
Recommended grade of oil		Edwards	Edwards	Edwards	Shell ROTELLA T20	-
		No. 15 or 17	No. 15 or 17	No. 15 or 17	or Edwards No. 17	-
Motor rating	(hp)	5.5	7.5	15	15	-
Minimum cooling water flow rate	(litres/min)	1	2	2.3	2.3	-

** Air is a suitable gas ballast for most operation * Ultimate vacuum measured on McLeod gauge.

† Running temperature should not exceed 110°C on all pumps ‡ High for evacuation — Low for forming

GENERAL DESCRIPTION AND WORKING PRINCIPLE

Introduction

The models ES2000, ES4000 and ES7500 rotary piston pumps have been developed for general vacuum duties in the industrial field and the model ES300/40 pump is a specialised development of the model ES7500 for automatic vacuum packaging applications. The basic pumping mechanism for this series of pumps is of the rotary piston/eccentric cam type and the differences in construction and lay-out of the various pumps are described in the text and the illustrations as follows:

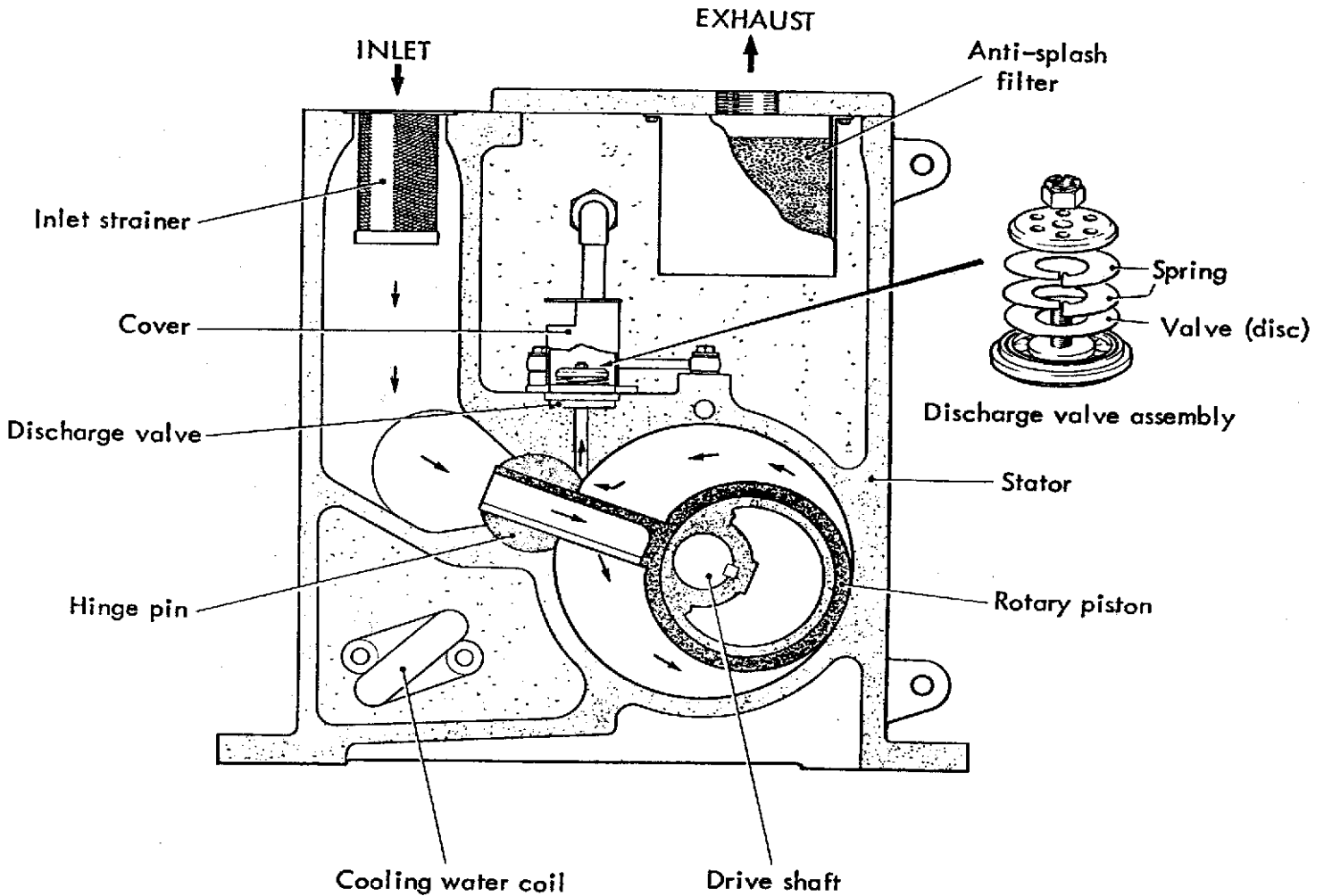

Fig. 1 ES2000 and ES4000 pumps - sectional view

Construction

Models ES2000 and ES4000 pumps.

Fig.1 shows the basic pumping mechanism components which essentially comprise a cam eccentrically keyed to a drive shaft and rotating inside a sleeve with an integral tongue. The sleeve and tongue together form the rotary piston which in turn reciprocates inside a moving hinge pin. The pumping mechanism is housed and rotates in the bore of the stator casing and the drive shaft is supported on roller bearings housed in the front cover and in the rear wall of the stator, respectively. Shaft sealing is effected by lip-type, Viton oil seals

The model ES4000 unit is a two cylinder version of the ES2000 pump, the pumping mechanisms operating in parallel and having an interconnecting port.

Models ES7500 and ES300/40 (Fig.1A)

These are single cylinder units and the pumping mechanism is of essentially similar design to that of the ES2000/4000 series. The drive shaft is supported in phosphor bronze plain bearings housed in the front and rear cover bosses respectively and the drive from the drive pulley is via a hub keyed to the shaft and bolted to the pulley. The drive pulley is supported on roller bearings which locate on the outer journal of the front cover boss and rotational balance is effected by counter-weights attached to the drive pulley and to the rear end of the shaft. Oil sealing is by means of Viton lip-type seals.

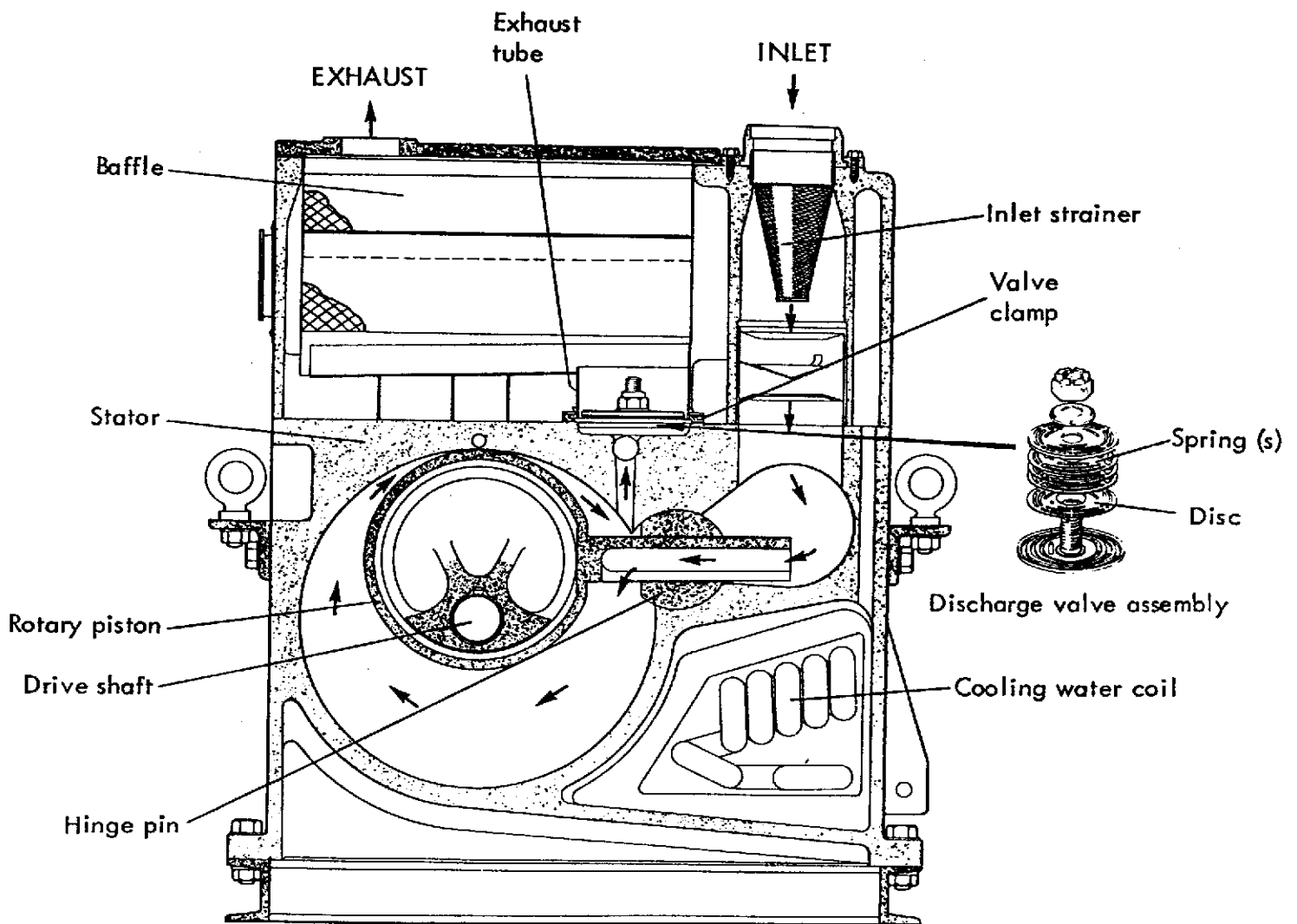

Fig.1A ES7500 and ES300/40 pumps - sectional view

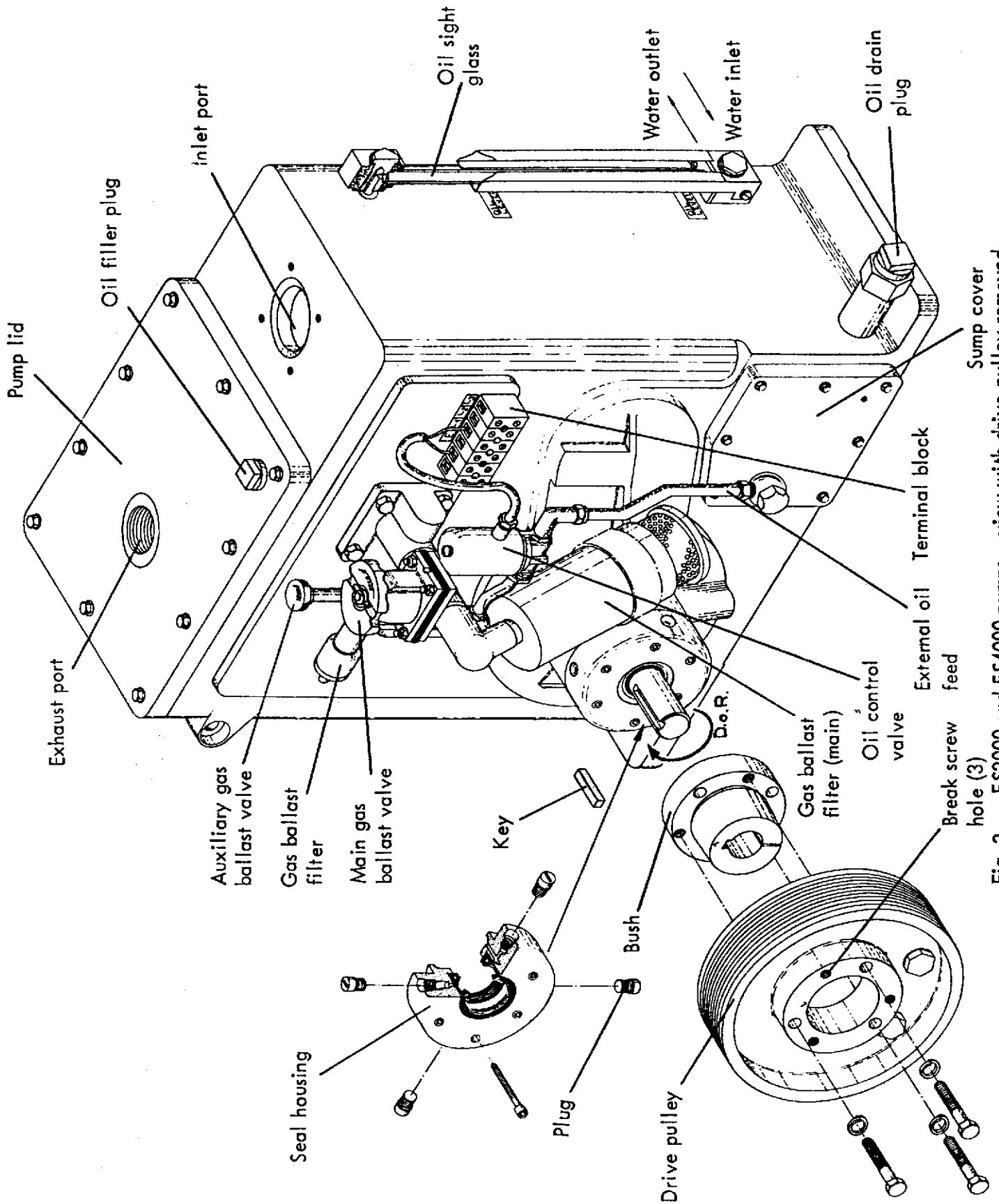

Fig. 2 ES2000 and ES4000 pumps - view with drive pulley removed

Working principle (Figs.1 & 1A)

The piston rotates eccentrically in the stator bore and makes an oil sealed contact with the stator wall, thus creating a rapidly expanding volume into which air/gas is induced from the pump inlet via the hollow piston tongue. Further rotation of the pumping mechanism isolates the pump inlet, reduces the volume, and compresses the gas for discharge through the exhaust valve.

The ES300/40 pump is a dual-action unit and provides an additional (vacuum) displacement complementary to the main displacement. This is achieved by introducing an auxiliary port in the pumping cycle before atmospheric pressure has been generated in the pump chamber.

Auxiliary systems

1. Oil system

Oil is circulated from the reservoir in the stator to the pumping mechanism via an external pipeline and solenoid-operated oil flow control valves - the pressure differential existing between the pump interior and atmosphere provides the circulating pressure for the oil system. An external oil filter is installed in the oil supply pipeline on the ES7500 and ES300/40 models.

To prevent oil spray emerging from the pump exhaust, a 'knit mesh' type filter is mounted on the underside of the pump lid on the model ES2000 and ES4000 pumps. The ES7500 and ES300/40 pumps are equipped with an internal baffle and filter arrangement.

All pumps are provided with oil filler and drain plugs and sight-glass oil level indicators.

2. Gas ballasting

The ES2000, ES4000 and ES7500 pumps incorporate a gas ballast facility to enable them to pump most condensable vapours directly without significant contamination of the pump oil. This entails the introduction of a quantity of gas or air at atmospheric pressure (via an externally mounted valve) into the volume between the moving piston and the discharge valve whilst the gas/vapour mixture in this volume is at a comparatively low pressure. When the volume of gas/vapour mixture is compressed prior to expulsion, the discharge valve opens before the partial pressure of the vapour component is high enough to cause it to condense.

The auxiliary gas ballast valve (mounted adjacent to the main ballast valve) should always be utilised except when pressures below 0.02 torr are required.

On ES300/40 pumps, the auxiliary pumping line, provides the gas ballast facility.

3. Cooling system

Gas ballasted pumps operate at a higher temperature than non-ballasted pumps due to the additional energy expended in compressing the ballast air. All pumps are water cooled by means of an internal cooling coil with external supply and return connexions. The recommended cooling water flows and pump operating temperatures are specified in DATA AND SPECIFICATIONS

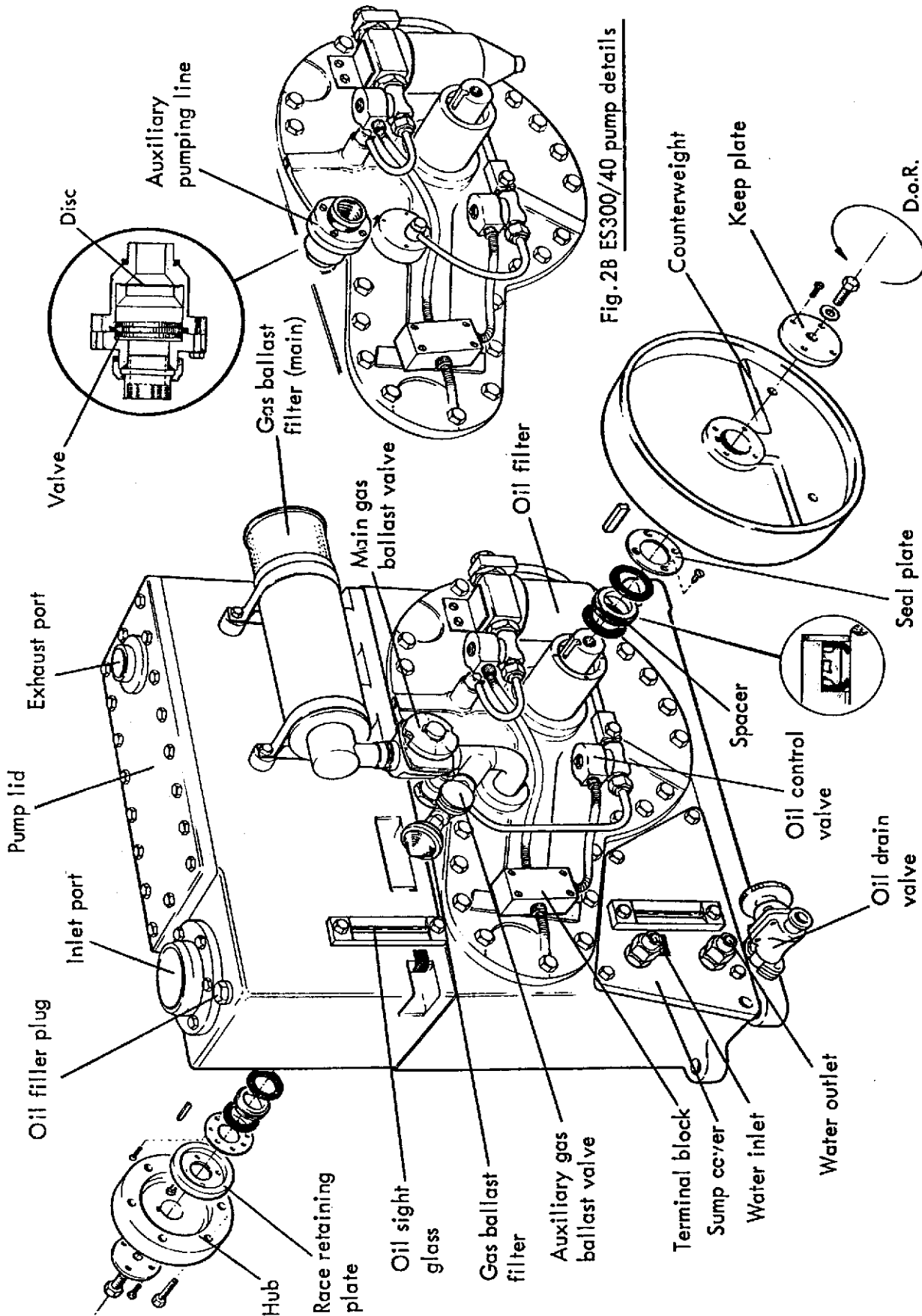

Fig. 2B ES300/40 pump details

Fig. 2A ES7500 pump - view with shaft seals dismantled

RECOMMENDED SPARES

The *spares kit comprises those items which may require renewal at the scheduled maintenance periods. Quantities listed are the number fitted to a standard pump (or pump outfit) and are not necessarily the quantity included in the spares kit.

Helium conversion kit

A list of items for conversion of a standard pump for helium operation will be supplied on request. These pumps are denoted by the prefix 'H2' immediately before the serial number on ES2000 and ES4000 units.

Spares List A (ES2000 pump - Code No. 03-A085-09-762)

Item	Description	Edwards Code No.	Qty.
1	*Spares Kit for ES2000 Pump Comprising:	03-A086-04-800	1
2	Shaft Seal (5572-10)	03-H021-09-002	2
3	Shaft Seal (3856-10)	03-H021-09-003	2
4	Ballast Valve	03-A086-04-033	1
5	Oil Indicator Glass	03-A086-00-084	1
6	Sealing Ring	03-H021-05-121	2
7	Compression Spring	03-A086-04-064	2
8	Plug 3/4in BSP	03-A050-09-005	1
9	Plug 1/2 in BSP	03-A070-14-010	2
10	Seal (Dowty Mk. 'B' 1/8 in BSP)	03-H021-04-001	4
11	Seal (Dowty Mk. 'B' 1/4 in BSP)	03-H021-04-002	5
12	Seal (Dowty Mk. 'D' 1/2 in BSP)	03-H021-04-004	11
13	Seal (Dowty Mk. 'F' 3/4 in BSP)	03-H021-04-006	1
14	'O' Ring	03-H021-05-185	2
15	Plug 1/8 in BSP	03-A070-14-012	4
16	Belt, Poly 'V' L Section (Pt. No. 500L8) MICROLAC L28 High solids purple. LOCTITE Screwlock LOCQUIC Primer Grade N. Shell ALVANIA 3 grease	03-H038-00-077	1

Spares List B (ES4000 Pump - Code No. 03-A083-07-765)

Item	Description	Edwards Code No.	Qty
1	*Spares Kit for ES4000 Pump	A8704-800	1
	Comprising:		
2	Shaft Seal (5572/10)	03-H021-09-002	2
3	Shaft Seal (3856/10)	03-H021-09-003	2
4	Ballast Valve	03-A086-04-033	2
5	Oil Indicator Glass	03-A086-00-084	1
6	Sealing Ring	03-H021-05-121	4
7	Compression spring	03-A086-04-064	2
8	Plug $\frac{3}{4}$ in BSP	03-A050-9-005	1
9	Plug $\frac{1}{2}$ in BSP	03-A070-14-010	2
10	Seal (Dowty Mk. 'B' $\frac{1}{8}$ in BSP)	03-H021-04-001	4
11	Seal (Dowty Mk. 'Bp' $\frac{1}{4}$ in BSP)	03-H021-04-002	5
12	Seal (Dowty Mk. 'D' $\frac{1}{2}$ in BSP)	03-H021-04-004	11
13	Seal (Dowty Mk. 'F' $\frac{3}{4}$ in BSP)	03-H021-04-006	1
14	'O' Ring	03-H021-05-185	2
15	Plug $\frac{1}{8}$ in BSP	03-A070-14-012	4
16	Belt, Poly 'V' L Section (Part No. 500L12) MICROLAC L28 High solids purple LOCTITE Screwlock LOCQUIC Primer Grade B Shell ALVANIA 3 grease	03-H038-00-078	1

Spares List C (ES7500 Pump - Code No. 03-A017-02-489)

Item	Description	Edwards Code No.	Qty.
1	Spares Kit	03-A016-01-802	1
	Comprising:		
2	Stator Gasket	03-A016-01-054	1
3	Cooling Coil Seal $\frac{1}{2}$ in BSP	03-A098-00-083	2
4	Washer	03-M011-00-011	2
5	Oil Seal (Viton)	03-A016-01-099	4
6	Banjo Bolt Seal $\frac{1}{2}$ in BSP	03-A098-00-083	6
7	Adaptor Seal	03-A016-01-102	2
8	Diaphragm for 1 in Speedivalve	03-C015-00-045	1
9	Sealing Ring VOR 0216	03-H021-05-026	2
10	Diaphragm for $\frac{1}{4}$ in Speedivalve	03-C015-00-042	1
11	Sealing Ring VOR 4A	03-H021-05-116	4
12	Ballast Seal VOR 0328	03-H021-05-044	1
13	Sight Glass Seal	03-A098-00-077	8
14	End Cap	03-A009-06-058	4
15	Sight Glass	03-A016-01-089	2
16	Inlet Sealing Ring VOR 0346	03-H021-05-061	1
17	Lid Gasket	03-A016-01-060	1
18	Filler Plug Seal	03-A016-01-102	1
19	Diaphragm for $\frac{1}{2}$ in Speedivalve	03-C015-00-047	1
20	Sealing Ring VOR 1119	03-H021-05-119	1
21	Ballast Valve	03-A016-01-134	1
22	Disc	03-A016-01-135	1
23	Spacer	03-A016-01-136	1
24	Washer, Dowty MK 13 - 1 in BSP	03-A016-01-102	1
25	Driving Belt Poly. 1065L12	03-H038-00-67	1
	$\frac{1}{2}$ in BSF x 5 in Long Set Screw Nut & Washer		1 set
	$\frac{5}{8}$ in BSF x $3\frac{1}{2}$ in Long Set Screw		1
	$\frac{3}{8}$ in BSF x $1\frac{1}{2}$ in Long Set Screw		4
	$\frac{1}{2}$ in BSF x $\frac{3}{4}$ in Long Set Screw		1

Spares List D (ES300/40 Pump - Code No. 03-A017-05-489)

Item	Description	Edwards Code No.	Qty.
1	Spares Kit	03-A016-01-802	1
	Comprising:		
2	Stator Gasket	03-A016-01-054	1
3	Cooling Coil Seal $\frac{1}{2}$ in BSP	03-A098-00-083	2
4	Washer	03-M011-00-011	2
5	Oil Seal (Viton)	03-A016-01-099	4
6	Banjo Bolt Seal $\frac{1}{2}$ in BSP	03-A098-00-083	6
7	Adaptor Seal	03-A016-01-102	2
8	Diaphragm for 1 in Speedivalve	03-C015-00-045	1
9	Sealing Ring VOR 0216	03-H021-05-026	2
10	Diaphragm for $\frac{1}{4}$ in Speedivalve	03-C015-00-042	1
11	Sealing Ring VOR 4A	03-H021-05-116	4
12	Ballast Seal VOR 0328	03-H021-05-044	1
13	Sight Glass Seal	03-A098-00-077	8
14	End Cap	03-A009-06-058	4
15	Sight Glass	03-A016-01-089	2
16	Inlet Sealing Ring VOR 0346	03-H021-05-061	1
17	Lid Gasket	03-A016-01-060	1
18	Filler Plug Seal	03-A016-01-102	1
19	Diaphragm for $\frac{1}{2}$ in Speedivalve	03-C015-00-047	1
20	Sealing Ring VOR 1119	03-H021-05-119	1
21	Ballast Valve	03-A016-01-134	1
22	Disc	03-A016-01-135	1
23	Spacer	03-A016-01-136	1
24	Washer, Dowty MK 13 - 1 in BSP	03-A016-01-102	1
25	Driving Belt Poly. 1065L12	03-H038-00-67	1
	$\frac{1}{2}$ in BSF x 5 in Long Set Screw Nut & Washer		1 set
	$\frac{5}{8}$ in BSF x $3\frac{1}{2}$ in Long Set Screw		1
	$\frac{3}{8}$ in BSF x $1\frac{1}{2}$ in Long Set Screw		4
	$\frac{1}{2}$ in BSF x $\frac{3}{4}$ in Long Set Screw		1

ACCESSORIES Optional

List A (ES2000 and ES4000 pumps)

Item	Description	Edwards Code No.	Qty.
1	Starter DOC 80/AL/4 (380/420V)	03-A064-02-002	1
2	Starter DOC 220/AL/2 (220/240V)	03-A064-02-004	
3	Oil mist filter CVP150	04-A062-14-000	1

List B (ES7500 and ES300/40 pumps)

Item	Description	Edwards Code No.	Qty.
1	Oil mist filter Model CVP 250	04-A062-08-000	1