

Instruction Manual

RV3, RV5, RV8 and RV12 Rotary Vane Vacuum Pumps



Declaration of Conformity

We, BOC Edwards,
Manor Royal,
Crawley,
West Sussex RH10 9LW, UK

declare under our sole responsibility that the product(s)

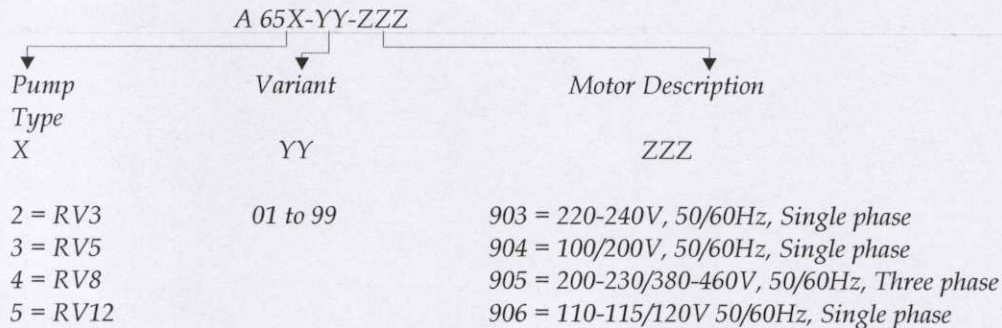

to which this declaration relates is in conformity with the following standard(s) or other normative document(s)

EN 292 IEC34 Parts 1, 5, 8†, 11* EN 1012-2 EN 61010-1 * C22.2 N° 77-1988 # C22.2 N° 100-92 # C22.2 N° 1010.1-92 # UL 3101-1 # UL 1004 # EN13463-1	Safety of Machinery: Basic Concepts, General Principles for Design. General Requirements for Rotating Electrical Machines. Compressors and Vacuum Pumps - Safety Requirements Part 2 Safety Requirements for Electrical Equipment for Measurement Control and Laboratory Use. Motors with Inherent Overheating Protection. Motors and Generators Safety Requirements for Electrical Equipment for Measurement, Control and Laboratory Use, Part I: General Requirements. Electrical Equipment for Laboratory Use, Part I: General Requirements. Electric Motors. Non Electrical Equipment for Potentially Explosive Atmosphere.
† Three-phase pumps only. * Single-phase pumps only. # Single-phase pumps only.	The pumps comply with EN 61010-1 when installed in accordance with the instruction manual supplied with the pumps. Canadian Standards Authority and Underwriters Laboratory.

following the provisions of

73/023/EEC 89/336/EEC 94/9/EC 98/37/EC	Low Voltage Directive. Electromagnetic Compatibility Directive. Equipment for use in Potentially Explosive Atmospheres (ATEX Directive) (Category 3GD) Internal Atmospheres Only. Machinery Directive.
---	---

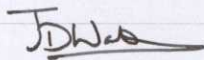

Dr J. D. Watson, Senior Technical Manager
Vacuum Equipment and Exhaust Management Product Divisions

17 JUNE 2003 SHORLETTAN

Date and Place

This product has been manufactured under a quality system registered to ISO9001

Declaration of Incorporation

We, BOC Edwards,
Manor Royal,
Crawley,
West Sussex, RH10 2LW, UK

declare under our sole responsibility that the machine(s)

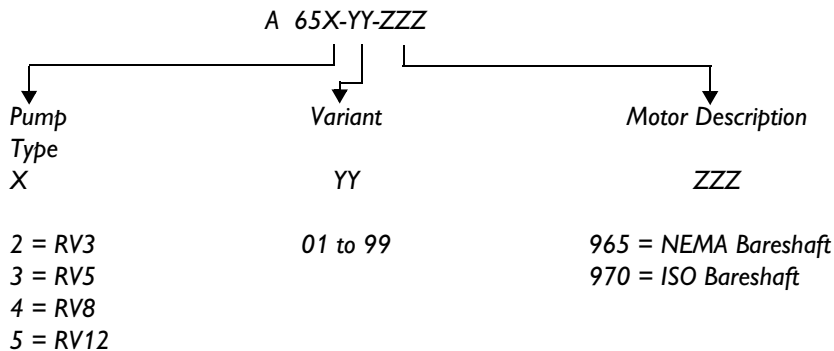

to which this declaration relates is intended to be incorporated into other equipment and not to function independently. The machine(s) is in conformity with the following standard(s) or other normative document(s)

EN 292 *
EN1012-2 *

Safety of Machinery: Basic Concepts, General Principles for Design.
Compressors and Vacuum Pumps - Safety Requirements Part 2.

The machine(s) must not be put into service until the equipment into which it is incorporated has been brought into conformity with the provisions of the Machinery Directive, 98/37/EC.

Stephen E. Omond

23.4.99 Shoneham

Date and Place

* When installed according to this instruction manual.

This product has been manufactured under a quality system registered to ISO9001

CONTENTS

Section	Title	Page
1	INTRODUCTION	1
1.1	Scope and definitions	1
1.2	ATEX directive implications	2
1.3	Description	4
1.4	Performance modes and controls	4
1.4.1	Mode selector	5
1.4.2	Gas-ballast control	5
1.5	Construction	5
2	TECHNICAL DATA	6
2.1	Operating and storage conditions	6
2.2	Performance	6
2.2.1	General	6
2.2.2	Performance characteristics	10
2.3	Mechanical data	11
2.3.1	General	11
2.3.2	Noise and vibration data	11
2.4	Electrical data: single-phase pumps	11
2.5	Electrical data: three-phase pumps	14
2.6	Lubrication data	14
3	INSTALLATION	15
3.1	Safety	15
3.2	System design considerations	15
3.3	Unpack and inspect	16
3.4	Locate the pump	16
3.5	Fill the pump with oil	18
3.6	Electrical installation: single-phase pumps	18
3.6.1	Check and configure the motor	18
3.6.2	Connect the pump to your electrical supply	19
3.6.3	Check the direction of rotation	21
3.7	Electrical installation: three-phase pumps	21
3.7.1	Check and configure the motor	21
3.7.2	Connect the pump to your electrical supply	22
3.7.3	Check the direction of rotation	22
3.8	Inlet and outlet connections	23
3.9	Leak-test the system	24
3.10	Electrical installation	24
3.10.1	Check and configure the motor	24
3.10.2	Connect the motor to the electrical supply	24
3.11	Check the direction of rotation	25

Section	Title	Page
4	OPERATION	26
4.1	ATEX directive implications	26
4.1.1	Introduction	26
4.1.2	Flammable/pyrophoric materials	26
4.1.3	Gas purges	27
4.2	How to use the pump controls	27
4.2.1	Mode selector	28
4.2.2	Gas-ballast control	28
4.3	Start-up procedure	29
4.4	To achieve ultimate vacuum	29
4.5	To pump condensable vapours	30
4.6	To decontaminate the oil	30
4.7	Unattended operation	31
4.8	Shut-down	31
5	MAINTENANCE	32
5.1	Safety information	32
5.2	Maintenance plan	34
5.3	Check the oil-level	35
5.4	Replace the oil	35
5.5	Inspect and clean the inlet-filter	36
5.6	Inspect and clean the gas-ballast control	36
5.7	Clean the oil-level sight-glass	36
5.8	Clean the motor fan-cover and enclosure	37
5.9	Clean and overhaul the pump	37
5.10	Fit new blades	37
5.11	Test the motor condition	37
5.12	Fault-finding	37
5.12.1	The pump has failed to start	37
5.12.2	The pump has failed to achieve the specified performance (has failed to reach ultimate vacuum)	38
5.12.3	The pump is noisy	38
5.12.4	The pump surface temperature is above 100 °C	38
5.12.5	The vacuum is not fully maintained after the pump is switched off	39
5.12.6	The pumping speed is poor	39
5.12.7	There is an external oil leak	39
6	STORAGE AND DISPOSAL	40
6.1	Storage	40
6.2	Disposal	40
7	SERVICE, SPARES AND ACCESSORIES	42
7.1	Introduction	42
7.2	Service	42
7.3	Spares	43
7.4	Accessories	44
7.4.1	Inlet catchpot	44

Section	Title	Page
7.4.2	Inlet dust filter	44
7.4.3	Inlet desiccant trap	44
7.4.4	Inlet chemical trap	44
7.4.5	Solenoid operated gas-ballast valve	44
7.4.6	Foreline trap	45
7.4.7	Solenoid operated pipeline valve	45
7.4.8	Outlet mist filter	45
7.4.9	Gas-ballast adaptor	45
7.4.10	Gravity oil drain kit	45
7.4.11	Vibration isolators	46
7.4.12	Oil drain-extension	46
7.4.13	Exhaust nozzle kit	46
8	ROTARY VACUUM PUMP PREPARED FOR USES WITH PFPE OILS	47
8.1	Summary	47
8.2	Installation	47
8.3	Maintenance	47
8.4	System Safety	47
9	BARE SHAFT PUMPS	48
9.1	Description	48
9.2	Fit the new motor to the pump	48

Illustrations

Figure	Title	Page
1	The RV pump (single-phase pump shown)	3
2	Performance characteristics in High Vacuum mode (pumping speed against inlet pressure)	10
3	Dimensions: mm	13
4	Motor voltage configuration: single-phase pumps	17
5	Three-phase electrical connections: 200-230 V	20
6	Three-phase electrical connections: 380-460 V	20
7	Inlet-filter assembly	32
8	Gas-ballast control assembly	33
9	Sight-glass assembly	34
10	Accessories	41
11	Fit the new motor to the pump	49

Tables

Table	Title	Page
1	Technical data (High Vacuum mode)	7
2	Technical data (High Throughput mode)	8
3	Performance characteristics	9
4	Electrical data (single-phase pumps with Item Numbers -903 or -906)	12
5	Electrical data (single-phase pumps with Item Numbers -904)	12
6	Electrical data (three-phase pumps with Item Numbers -905)	14
7	Maintenance plan	34
8	Spares and Accessories	43

Associated publications

Publication title	Publication Number
Vacuum pump and vacuum system safety	P300-20-000

1 INTRODUCTION

1.1 Scope and definitions

This manual provides installation, operation and maintenance instructions for the Edwards RV3, RV5, RV8 and RV12 Rotary Vane Pumps. You must use your pump as specified in this manual. Read this manual before you install and operate your pump.

Important safety information is highlighted as WARNING and CAUTION instructions; you must obey these instructions. The use of WARNINGS and CAUTIONS is defined below.

WARNING

Warnings are given where failure to observe the instruction could result in injury or death to people.

CAUTION

Cautions are given where failure to observe the instruction could result in damage to the equipment, associated equipment and process.

The units used throughout this manual conform to the SI international system of units of measurement.

In accordance with the recommendations of IEC1010, the following warning symbols are on the pump:



Warning - refer to accompanying documents.



Warning - risk of electric shock.



Warning - hot surface.



Warning - risk of catastrophic failure.

1.2 ATEX directive implications



- This equipment is designed to meet the requirements of Group II Category 3 equipment in accordance with Directive 94/9/EC of the European Parliament and the Council of 23rd March 1994 on the approximation of the laws of the Member States concerning equipment and protective systems intended for use in potentially explosive atmospheres. (The ATEX Directive).

The ATEX Category 3 applies in respect of potential ignition sources internal to the equipment. An ATEX Category has not been assigned in respect of potential ignition sources on the outside of the equipment as the equipment has not been designed for use where there is an external potentially explosive atmosphere.

There is no potential source of ignition within the pump during normal operation but there may be potential sources of ignition under conditions of predicted and rare malfunction as defined in the Directive. Accordingly, although the pump is designed to pump flammable materials and mixtures, operating procedures should ensure that under all normal and reasonably predicted conditions, these materials and mixtures are not within explosive limits. Category 3 is considered appropriate for the avoidance of ignition in the case of a rare malfunction which allows flammable materials or mixtures to pass through the pump while within their explosive limits.

- When flammable or pyrophoric materials are present within the equipment you must:
 - Not allow air to enter the equipment.
 - Ensure that the system is leak tight.
 - Use an inert gas purge (for example, a nitrogen purge) to dilute any flammable gases or vapours entering the pump inlet, and/or use an inert gas purge to reduce the concentration of flammable gases or vapours in the pump and in the exhaust pipeline to less than one quarter of the gases' published lower explosive limits (LEL).
- For further information, please contact BOC Edwards: refer to the Addresses page at the end of this manual for details of your nearest BOC Edwards company.

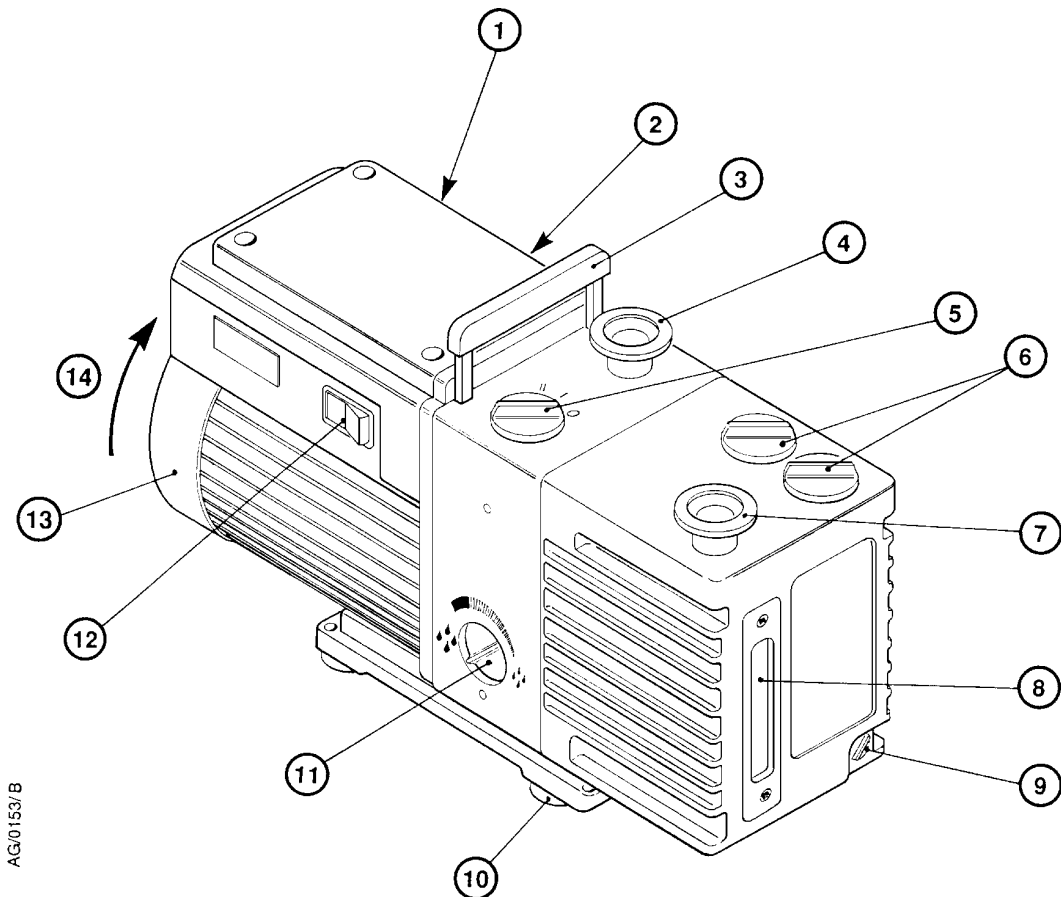

AG/0153/B

- | | | |
|---|--------------------------|---|
| 1. Electrical inlet-connector | 4. NW25 inlet-port | 10. Rubber feet (4 off) |
| 2. Voltage indicator | 5. Gas-ballast control | 11. Mode selector |
| 3. Lifting handle (lifting bracket on RV8 and RV12 pumps and Bareshaft) | 6. Oil filler-plug | 12. On/off switch (single-phase pumps only) |
| | 7. NW25 outlet-port | 13. Motor fan-cover |
| | 8. Oil-level sight-glass | 14. Correct direction of rotation |
| | 9. Oil drain-plug | |

Figure 1 - The RV pump (single-phase pump shown)

1.3 Description

The Edwards RV rotary vane pump is shown in Figure 1. Refer to Figure 1 for item numbers in brackets in the following descriptions. The RV pumps are two-stage, oil-sealed, sliding-vane vacuum pumps. The pump has NW25 inlet (4) and outlet (7) ports, a gas-ballast control (5) and a mode selector (11). When the pump is switched off, an inlet-valve seals the inlet and prevents the suck-back of air and oil into the vacuum system.

The RV3 and RV5 pumps have a retractable lifting handle (3). The RV8 and the RV12 pumps are fitted with a lifting bracket for use with suitable lifting equipment.

An oil-pump delivers pressurised oil to the vacuum pumping mechanism in the RV pump. You can inspect the level and condition of the oil in the oil-box through a sight-glass (8). Two oil filler-plugs (6) and an oil drain-plug (9) are provided on the oil-box.

The pump mechanism is driven directly by a single-phase or three-phase electric motor through a flexible motor-coupling. The motor is totally enclosed and is cooled by the motor cooling-fan which directs air along the motor fins. The pumps are cooled by an additional fan attached to the motor-coupling.

Single-phase motors are fitted with an on/off switch (12) and a thermal overload device. When the motor is too hot, the thermal overload device switches off the pump. The thermal overload device has an automatic reset; when the motor cools down, the device resets and (unless you have incorporated suitable control equipment which must be manually reset: see Section 3.6.2), the motor will restart.

The pump is mounted on a base plate on rubber feet (10). Details of suitable vibration isolators and other accessories are provided in Section 7.

If the pump is prepared for uses with PFPE oils, details are provided in Section 8.

1.4 Performance modes and controls

The pump has two controls : the mode selector (11) and the gas-ballast control (5). Six possible combinations of these controls allow for a wide choice of operating characteristics so you can optimize the performance of the pump for a given application.

1.4.1 Mode selector

The mode selector has two positions; refer to Section 4.2 to select these positions. Throughout the rest of this manual, the following convention is used:

- The High Vacuum mode is specified by the ♠ symbol.
- The High Throughput mode is specified by the ♣ symbol.

With the mode selector set to High Vacuum mode ♠, pressurised oil is fed to the low vacuum stage only. In this mode of operation, the pump provides the best possible ultimate vacuum.

With the mode selector set to High Throughput mode ♣, pressurised oil is fed to the high vacuum and low vacuum stages. In this mode of operation, the pump can sustain long-term high inlet pressures.

1.4.2 Gas-ballast control

To pump high vapour loads, gas-ballast is delivered into the pump to prevent condensation of the vapour carried by the pumped gases.

Air can be introduced to the low vacuum stage through the gas-ballast valve. Alternatively, an inert gas such as nitrogen can be supplied through a suitable external valve.

The gas-ballast control has three positions :

- Closed (position '0')
- Low flow (position 'I')
- High flow (position 'II').

1.5 Construction

The pump-shafts and rotors are made of high-grade cast-iron. The pump-body and oil-box are made from cast-aluminium. All surfaces of the pump which are exposed to the pumped gases are free from copper, zinc and cadmium.

Other materials of construction include fluorocarbon elastomer, nitrile, silicon, chemically-resistant polymers, nickel and stainless steel.

2 TECHNICAL DATA

2.1 Operating and storage conditions

Ambient temperature range (operation)	12 to 40 °C
Normal surface temperature of the pump-body at ultimate vacuum (operation), ambient temperature of 20 °C	50 to 70 °C
Maximum humidity (operation)	90% RH
Ambient temperature range (storage)	-30 to 70 °C

2.2 Performance

2.2.1 General

Note: In Tables 1 and 2, total pressures have been measured by a capacitance diaphragm gauge on a vacuum chamber without a cold trap, as specified by Pneurop Standard 6602 (1979).

High Vacuum mode ▲ performance	See Table 1
High Throughput mode ● performance	See Table 2
Suckback protection	1×10^{-5} mbar.l.s ⁻¹ , 1×10^{-3} Pa.l.s ⁻¹
Maximum initial pressure rise with no gas ballast flow	1×10^{-1} mbar.l, 1×10^1 Pa.l

	RV3	RV5	RV8	RV12
Maximum displacement (m ³ h ⁻¹)				
50 Hz electrical supply	3.7	5.8	9.7	14.2
60 Hz electrical supply	4.5	7.0	11.7	17.0
Maximum pumping speed (m ³ h ⁻¹) Pneurop 6602 (1979)				
50 Hz electrical supply	3.3	5.1	8.5	12.0
60 Hz electrical supply	3.9	6.2	10.0	14.2
Maximum permitted inlet pressure and gas-ballast inlet pressure: bar gauge	0.5	0.5	0.5	0.5
Pa	1.5×10^5	1.5×10^5	1.5×10^5	1.5×10^5
Maximum permitted outlet pressure: bar gauge	1	1	1	1
Pa	2×10^5	2×10^5	2×10^5	2×10^5

HIGH VACUUM MODE ◆									
Parameter	Units	RV3		RV5		RV8		RV12	
		1-phase	3-phase	1-phase	3-phase	1-phase	3-phase	1-phase	3-phase
Gas-ballast control closed (position '0') Ultimate total pressure	mbar Pa	2 × 10 ⁻³ 2 × 10 ⁻¹		2 × 10 ⁻³ 2 × 10 ⁻¹		2 × 10 ⁻³ 2 × 10 ⁻¹		2 × 10 ⁻³ 2 × 10 ⁻¹	
Gas-ballast control low flow (position 'I') Ultimate total pressure	mbar Pa	3 × 10 ⁻² 3		3 × 10 ⁻² 3		3 × 10 ⁻² 3		3 × 10 ⁻² 3	
Gas-ballast flow	1.min ⁻¹	5		5		5		5	
Maximum water vapour pumping rate	kg.h ⁻¹	0.06	0.04	0.06	0.04	0.06	0.04	0.06	0.04
Maximum water vapour inlet pressure	mbar Pa	27 2.7 × 10 ³	18 1.8 × 10 ³	16 1.6 × 10 ³	11 1.1 × 10 ³	10 1 × 10 ³	7 7 × 10 ²	7 7 × 10 ²	5 5 × 10 ²
Gas-ballast control high flow (position 'II') Ultimate total pressure	mbar Pa	1.2 × 10 ⁻¹ 1.2 × 10 ¹		1 × 10 ⁻¹ 1 × 10 ¹		6 × 10 ⁻² 6		6 × 10 ⁻² 6	
Gas-ballast flow	1.min ⁻¹	14		14		16		16	
Maximum water vapour pumping rate	kg.h ⁻¹	0.22	0.12	0.22	0.12	0.22	0.20	0.29	0.25
Maximum water vapour inlet pressure	mbar Pa	80 8 × 10 ³	54 5.4 × 10 ³	50 5.0 × 10 ³	32 3.2 × 10 ³	38 3.8 × 10 ³	34 3.4 × 10 ³	32 3.2 × 10 ³	28 2.8 × 10 ³

Table 1 - Technical data (High Vacuum mode)

HIGH THROUGHPUT MODE									
Parameter	Units	RV3		RV5		RV8		RV12	
		1-phase	3-phase	1-phase	3-phase	1-phase	3-phase	1-phase	3-phase
Gas-ballast control closed (position '0') Ultimate total pressure	mbar Pa	3 × 10 ⁻² 3	3 × 10 ⁻² 3	3 × 10 ⁻² 3	3 × 10 ⁻² 3	3 × 10 ⁻² 3	3 × 10 ⁻² 3	3 × 10 ⁻² 3	3 × 10 ⁻² 3
Gas-ballast control low flow (position 'I') Ultimate total pressure	mbar Pa	6 × 10 ⁻² 6	6 × 10 ⁻² 6	6 × 10 ⁻² 6	6 × 10 ⁻² 6	4 × 10 ⁻² 4	4 × 10 ⁻² 4	4 × 10 ⁻² 4	4 × 10 ⁻² 4
Gas-ballast flow	1.min ⁻¹	5	5	5	5	5	5	5	5
Maximum water vapour pumping rate	kg.h ⁻¹	0.06	0.04	0.06	0.04	0.06	0.04	0.06	0.04
Maximum water vapour inlet pressure	mbar Pa	27 2.7 × 10 ³	18 1.8 × 10 ³	16 1.6 × 10 ³	11 1.1 × 10 ³	10 1 × 10 ³	7 7 × 10 ²	7 7 × 10 ²	5 5 × 10 ²
Gas-ballast control high flow (position 'II') Ultimate total pressure	mbar Pa	1.2 × 10 ⁻¹ 1.2 × 10 ¹	1.2 × 10 ⁻¹ 1.2 × 10 ¹	1 × 10 ⁻¹ 1 × 10 ¹	1 × 10 ⁻¹ 1 × 10 ¹	6 × 10 ⁻² 6	6 × 10 ⁻² 6	6 × 10 ⁻² 6	6 × 10 ⁻² 6
Gas-ballast flow	1.min ⁻¹	14	14	14	14	16	16	16	16
Maximum water vapour pumping rate	kg.h ⁻¹	0.22	0.12	0.22	0.12	0.22	0.20	0.29	0.25
Maximum water vapour inlet pressure	mbar Pa	80 8 × 10 ³	54 5.4 × 10 ³	50 5.0 × 10 ³	32 3.2 × 10 ³	38 3.8 × 10 ³	34 3.4 × 10 ³	32 3.2 × 10 ³	28 2.8 × 10 ³

Table 2 - Technical data (High Throughput mode)

GAS-BALLAST CONTROL						
MODE SELECTOR POSITION	Closed (position '0')		Low flow (position 'I')		High flow (position 'II')	
	Ultimate total pressure mbar	Pa	Ultimate total pressure mbar	Pa	Ultimate total pressure mbar	Pa
High Vacuum mode ●	2×10^{-3}	2×10^{-1}	3×10^{-2}	3	1.2×10^{-1} (RV3) 1.0×10^{-1} (RV5) 6.0×10^{-2} (RV8/12)	1.2×10^1 (RV3) 1.0×10^1 (RV5) 6.0 (RV8/12)
	Use for the best ultimate pressure		Maximum water vapour pumping rate 1-phase pumps	3-phase pumps	Maximum water vapour pumping rate 1-phase pumps	3-phase pumps
			0.06 kg.h ⁻¹	0.04 kg.h ⁻¹	0.22 kg.h ⁻¹ (RV3/5/8) 0.29 kg.h ⁻¹ (RV12)	0.12 kg.h ⁻¹ (RV3/5) 0.20 kg.h ⁻¹ (RV8) 0.25 kg.h ⁻¹ (RV12)
	Ultimate total pressure mbar		Pa	Ultimate total pressure mbar	Pa	Ultimate total pressure mbar
High Throughput mode ●	3×10^{-2}	3	6×10^{-2} (RV3/5) 4×10^{-2} (RV8/12)	6 (RV3/5) 4 (RV8/12)	1.2×10^{-1} (RV3) 1.0×10^{-1} (RV5) 6.0×10^{-2} (RV8/12)	1.2×10^1 (RV3) 1.0×10^1 (RV5) 6.0 (RV8/12)
	Use for continuous inlet pressure above 50 mbar/5 x 10 ³ Pa		Maximum water vapour pumping rate 1-phase pumps	3-phase pumps	Maximum water vapour pumping rate 1-phase pumps	3-phase pumps
			0.06 kg.h ⁻¹	0.04 kg.h ⁻¹	0.22 kg.h ⁻¹ (RV3/5/8) 0.29 kg.h ⁻¹ (RV12)	0.12 kg.h ⁻¹ (RV3/5) 0.20 kg.h ⁻¹ (RV8) 0.25 kg.h ⁻¹ (RV12)
	Ultimate total pressure mbar		Pa	Ultimate total pressure mbar	Pa	Ultimate total pressure mbar

Table 3 - Performance characteristics

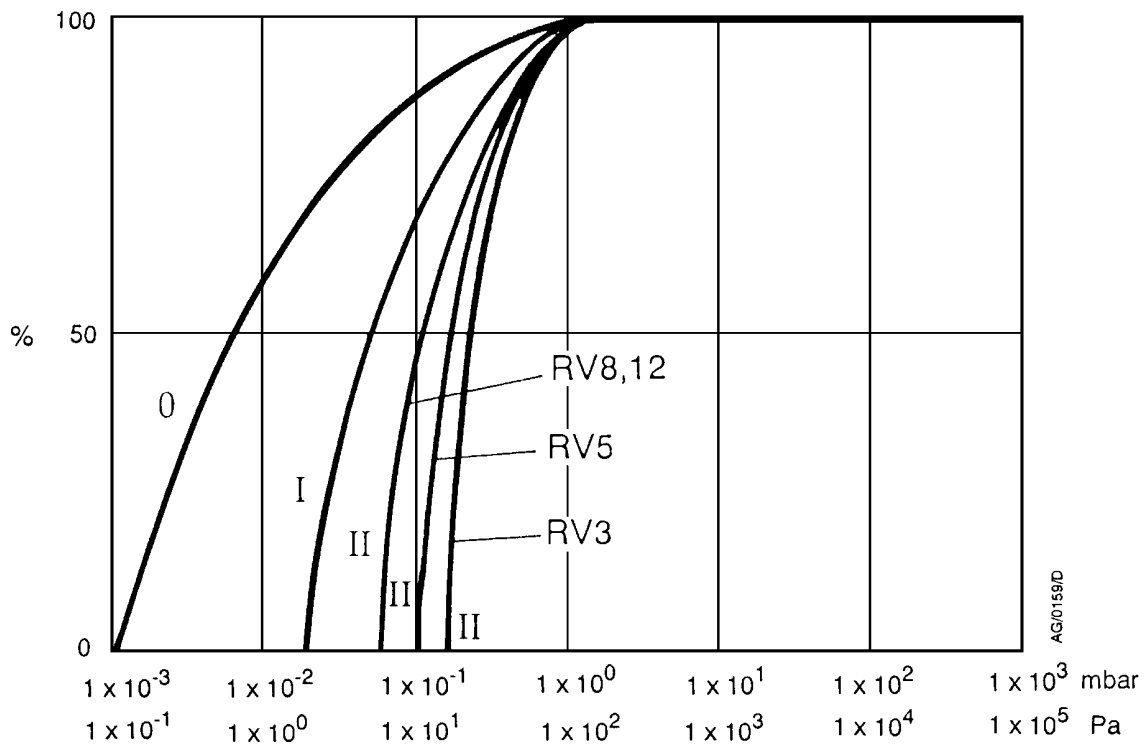

Figure 2 - Performance characteristics in High Vacuum mode (pumping speed against inlet pressure)

2.2.2 Performance characteristics

Note: Typical for hydrocarbon oil

The following performance characteristics are typical for hydrocarbon oil.

The positions of the mode selector and the gas-ballast control define the performance characteristics of the pump. These performance characteristics are listed fully in Tables 1 and 2.

Table 3 gives the ultimate vacuum and maximum water vapour inlet pressure for each of the six possible combinations of control positions. The curves 0, I, and II in Figure 2 show the relationship between inlet pressure and pumping speed for High Vacuum mode \blacklozenge .

2.3 Mechanical data

2.3.1 General

Overall dimensions	See Figure 3			
Degree of protection (IEC 34-5: 1981)	IP44 (single-phase pumps) IP54 (three-phase pumps)			
Maximum tilt angle	10 °			
Motor rotational speed (50 Hz supply)	1470 r.min ⁻¹			
Motor rotational speed (60 Hz supply)	1760 r.min ⁻¹			
	RV3	RV5	RV8	RV12
Maximum mass, without oil (kg)	21.6	21.5	26.0	26.3
Maximum mass, Bareshaft pump (kg)	14.0	14.0	16.5	17.5

2.3.2 Noise and vibration data

Sound pressure, measured at ultimate vacuum 1 metre from the end of the pump to ISO 11201, High Vacuum mode ♠, 50 Hz operation	1-phase	3-phase
Vibration severity: measured at the inlet port to ISO 2372 (1974)	48 dB (A) Class 1C	50 dB(A) Class 1C

2.4 Electrical data: single-phase pumps

Note: We recommend that you use fuses of the maximum ratings specified in Tables 4 and 5. You must not use fuses of a higher rating.

The dual-voltage, dual-frequency motor is designed for a single-phase electrical supply and is suitable for 50 Hz or 60 Hz operation. The motor can be manually switched between nominal supply voltages of 110-120 V and 220-240 V (refer to Section 3.6.1).

When you start a cold pump, the motor will draw the start-up current shown in Tables 4 and 5 for up to several seconds, so you must use a slow-blow fuse to prevent unnecessary fuse failure during pump start-up. Within five minutes, as the oil in the pump warms up, the current drawn will slowly reduce to the full load current specified in Tables 4 and 5.

Pump	Nominal supply (V)	Frequency (Hz)	Power (W)	Full load current (A)	Start-up current	Maximum fuse rating (A)
RV3 and RV5	220-240	50	250	2.4	15.6	5
	230-240	60	300	2.2	15.2	5
	110	50	250	4.6	29.4	10
	115-120	60	300	4.4	31.5	10
RV8 and RV12	220-240	50	450	4.0	18.0	5
	230-240	60	550	3.6	18.0	5
	110	50	450	7.8	34.0	13
	115-120	60	550	7.2	34.0	13

Table 4 - Electrical data (single-phase pumps with Item Numbers -903 or -906)

Pump	Nominal supply (V)	Frequency (Hz)	Power (W)	Full load current (A)	Start-up current	Maximum fuse rating (A)
RV3 and RV5	200	50	250	2.8	19.4	5
	200-210	60	300	2.4	19.5	5
	100	50	250	5.4	37.0	10
	100-105	60	300	4.6	39.0	10
RV8 and RV12	200	50	450	3.9	21.0	5
	200-210	60	550	3.8	20.6	5
	100	50	450	7.6	40.0	13
	100-105	60	550	7.6	41.5	13

Table 5 - Electrical data (single-phase pumps with Item Numbers -904)

Note: The fuse type chosen should be either, time delay type CC or a type M, or in the UK they should be to BS 88.

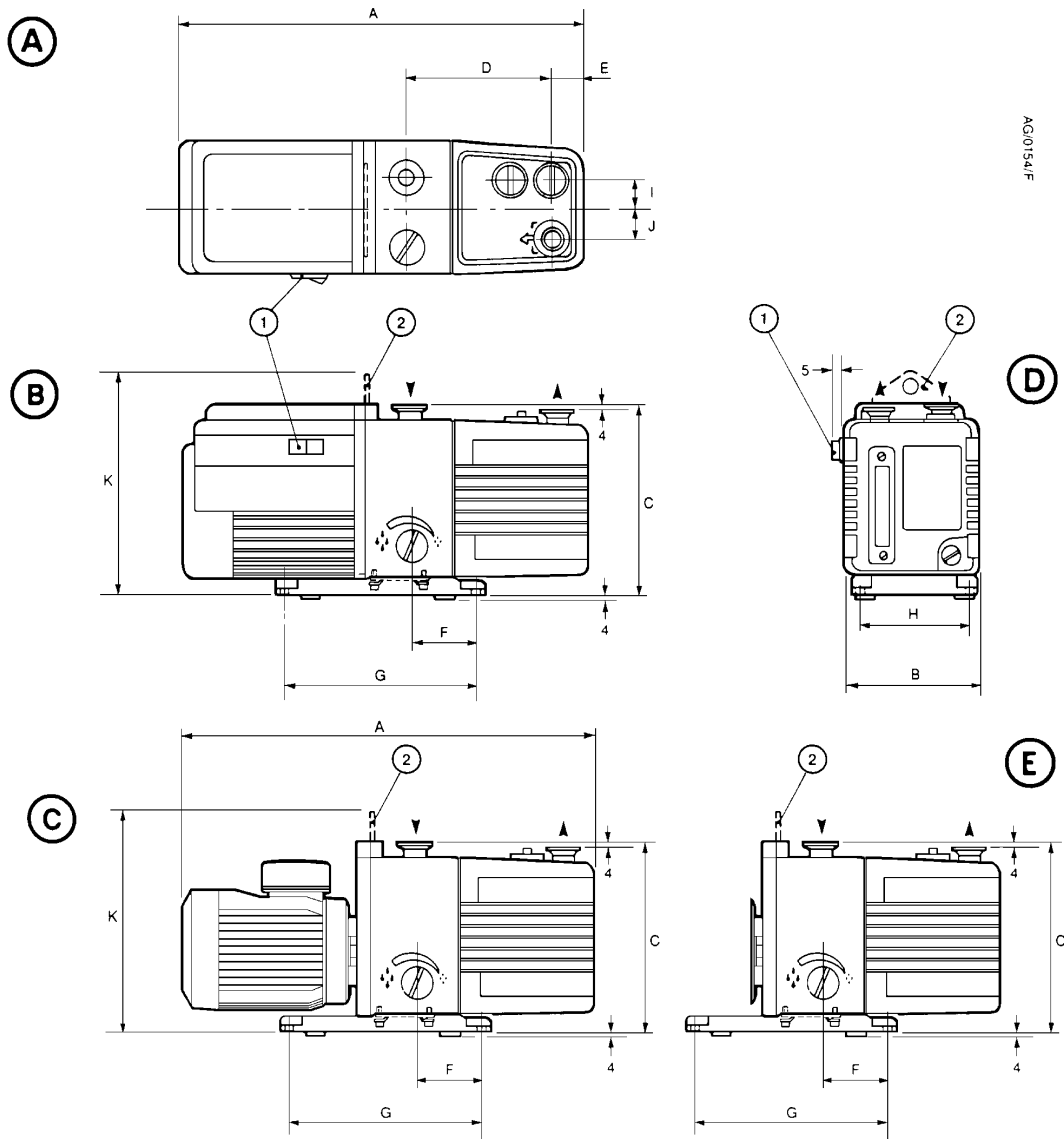

- 1. On/off switch (single-phase pumps only)
- 2. Lifting bracket (RV8 and RV12 pumps only) and all Bareshaft pumps

- A Top view of single-phase pump
- B Side view of single-phase pump
- C Side view of three-phase pump
- D Front view of single-phase pump
- E Bare shaft pump

Pump	A		B	C	D	E	F	G	H	I	J	K
RV3	430*	429†	158	225	127	29	78	230	120	37	32	-
RV5	430*	429†	158	225	127	29	78	230	120	37	32	-
RV8	470*	469†	158	225	161	35	78	230	120	37	32	261
RV12	490*	489†	158	225	181	35	78	230	120	37	32	261

* Single-phase pumps

† Three-phase pumps

Figure 3 - Dimensions: mm

2.5 Electrical data: three-phase pumps

The dual-voltage, dual-frequency motor is designed for a three-phase electrical supply and is suitable for 50Hz or 60Hz operation. The motor can be manually switched between nominal supply voltages of 220-240v and 380-460v (refer to section 3.7.1). Pumps are supplied pre-set for nominal 380-460v electrical supplies.

When you start a cold pump, the motor will draw the start-up current shown in Table 6 for up to 0.5 seconds. The current will then reduce quickly as the motor reaches rated rotational speed. Within 5 minutes, as the oil and pump warms up, the current drawn will slowly reduce to a maximum of the full load current specified in Table 6.

When you start a warm pump, the motor will draw the start-up current shown in Table 6 for up to 0.5 seconds. The current drawn will then immediately fall to a maximum of the full load current.

Electrical short-circuit and ground-fault protection of the pump will be provided by fitting Class CC fuses of the values shown in Table 6 at the point of connection to the supply. If these are not available in your country of use, Type aM European fuses of the same rating can also be used.

Pump	Nominal supply (V)	Frequency (Hz)	Power (W)	Full load current (A)	Start-up current (A)	Recommended fuse rating (A)
RV3 and RV5	200-220	50	250	1.7	10.2	2.5
	200-230	60	300	1.7	10.2	2.5
	380-415	50	250	1.0	5.7	2.5
	460	60	300	1.0	7.0	2.5
RV8 and RV12	200-220	50	450	2.5	14.0	4
	200-230	60	550	2.9	12.0	4
	380-415	50	450	1.5	9.0	2.5
	460	60	550	1.5	8.7	2.5

Table 6 - Electrical data (three-phase pumps with Item Numbers -905)

2.6 Lubrication data

Note: Edwards Health and Safety Data sheets for rotary pump oils are available on request.

Recommended oil*	Edwards Ultragrade 19 in hydrocarbon prepared pumps. Krtox 1506 or Fomblin 06/6 in PFPE prepared pumps.			
Oil capacity (litres)	RV3	RV5	RV8	RV12
Maximum	0.70	0.70	0.75	1.00
Minimum	0.42	0.42	0.45	0.65

* To operate the pump when the ambient temperature is outside the limits specified in Section 2.1, or to optimise the pump performance when you pump condensable vapours, you may need to use a different oil.

3 INSTALLATION

3.1 Safety

WARNING

The hydrocarbon prepared RV pump is not recommended for pumping hazardous substances. PFPE prepared pumps are suitable for oxygen applications. Refer to Section 8

You must ensure that the RV pump is suitable for your application. If you have any doubt as to the suitability of the RV pump for your application, refer to the Edwards guidelines on vacuum pump and vacuum system safety (see the Associated publications at the end of the Contents list at the front of this manual).

The installation of your RV pump must be performed by a suitably trained and supervised technician. Obey the safety instructions listed below when you install the pump, especially when you connect the pump into an existing system. Details of specific safety precautions are given at the appropriate point in the instructions.

- Wear the appropriate safety-clothing when you come into contact with contaminated components.
- Vent and purge your vacuum system before you start installation work.
- Ensure that the installation technician is familiar with the safety procedures which relate to the pump-oil and the products handled by the pumping system. Take suitable precautions to avoid the inhalation of oil mist and excessive skin contact with pump-oil, as prolonged exposure can be harmful.
- Disconnect the other components in the pumping system from the electrical supply so that they cannot be operated accidentally.

3.2 System design considerations

Consider the following points when you design your pumping system:

- Use a suitable valve to isolate the pump from your vacuum system if you need to allow the pump to warm up before you pump condensable vapours, or to provide additional system protection when the pump is switched off.
- Avoid high levels of heat input to the pump from the process gases, otherwise the pump may overheat and seize, and cause the motor thermal overload device to open.
- If you use the pump in a high ambient temperature and have a high gas throughput, the temperature of the pump-body may exceed 70 °C and you must fit suitable guards to prevent contact with hot surfaces.
- Make sure that the exhaust pipeline cannot become blocked. If you have an exhaust-isolation valve, make sure that you cannot operate the pump with the valve closed.

- Provide for a purge of inert gas when you shut down the pumping system, to dilute dangerous gases to safe concentrations. A suitable gas ballast adaptor for introduction of purge gas into the pump is available as an accessory (see Section 7.4.9).

3.3 Unpack and inspect

Remove all packing materials, remove the pump from its packing-box, remove the protective covers from the inlet and outlet-ports and inspect the pump. If the pump is damaged, notify your supplier and the carrier in writing within three days; state the Item Number of the pump together with your order number and your supplier's invoice number. Retain all the packing materials for inspection. Do not use the pump if it is damaged.

If the pump is not to be used immediately, replace the protective covers. Store the pump in suitable conditions, as described in Section 6.1.

3.4 Locate the pump

WARNING

Use suitable lifting equipment to move the RV8 or RV12 pump.
The mass of the RV8 and RV12 pumps is approximately 26 kg.

The RV3 and RV5 pumps have a lifting handle which you can use to move the pump by hand. If you wish to use mechanical lifting equipment, do not attach the equipment to the handle; for stability, use slings around the motor and the pump-body.

Do not lift the RV8 and RV12 pumps by hand; attach your mechanical lifting equipment to the lifting bracket on the pump. You do not need to use slings to move the RV8 and RV12 pumps.

Provide a firm, level platform for the pump. Locate the pump so that the oil-level sight-glass is visible and the oil filler-plug, oil drain-plug, mode selector and gas-ballast control are accessible.

If your pump will be located inside an enclosure, make sure that there is adequate ventilation at both ends of the pump, so that the ambient temperature around the pump does not exceed 40 °C. There must be a minimum space of 25 mm between the pump and the enclosure walls.

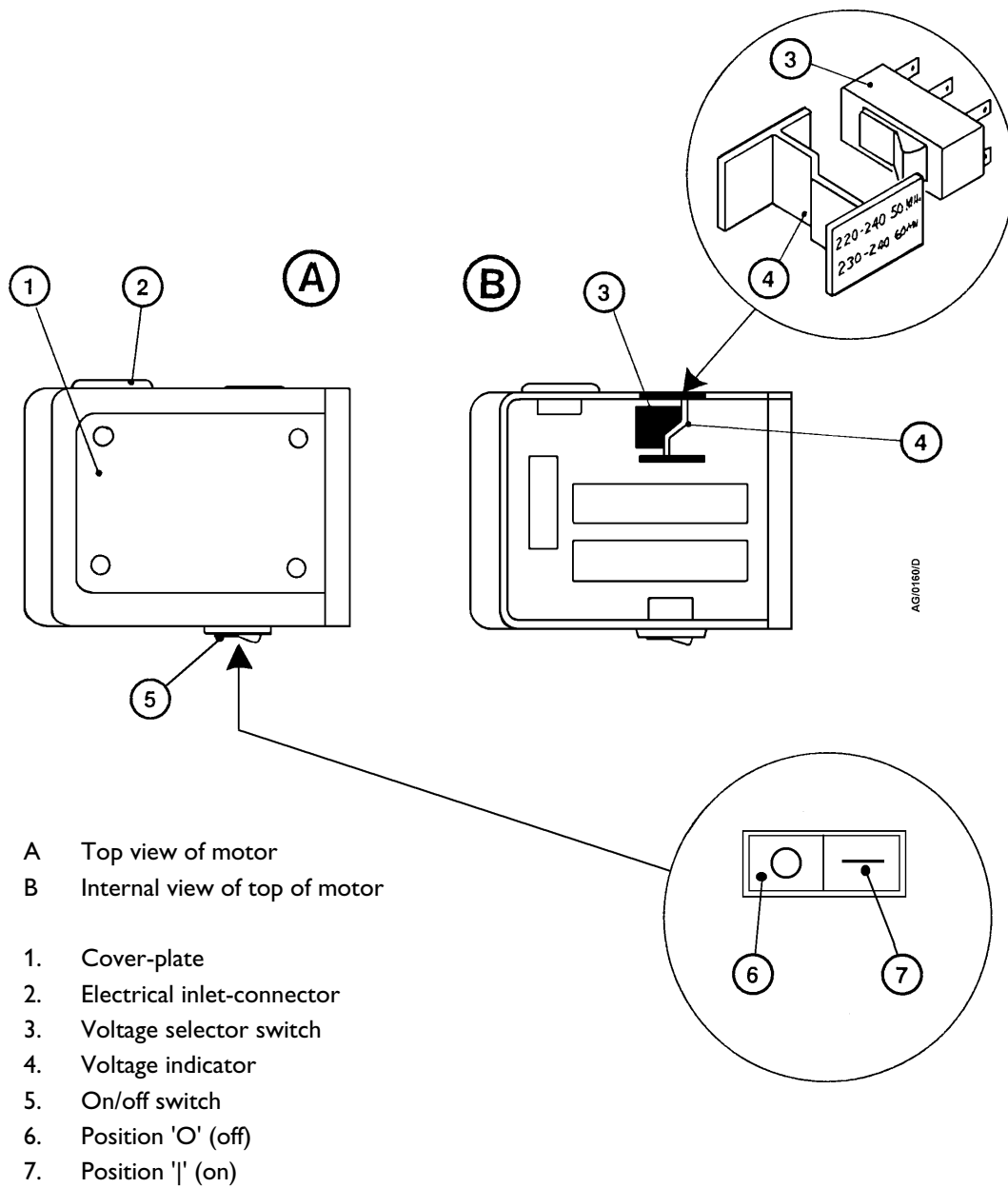

Figure 4 - Motor voltage configuration: single-phase pumps

3.5 Fill the pump with oil

WARNING

If you use a hydrocarbon prepared pump, you must not use the pump to process oxygen in concentrations greater than 25 % in volume. If you do, there is a risk of fire or explosion in the oil-box of the pump. PFPE prepared pumps are available.
Refer to Section 8

Fill the pump with oil as described below. Refer to Section 2 for the recommended oil. Refer to Figure 1 for the item numbers in brackets.

1. Remove one of the oil filler-plugs (6)
2. Pour oil into the pump until the oil-level just reaches the MAX mark on the bezel at the top of the sight-glass (8). If the oil-level goes above the MAX mark, remove the drain-plug (9) and drain the excess oil from the pump.
3. After a few minutes, recheck the oil-level. If the oil-level is now below the MAX mark, pour more oil into the pump.
4. Refit the oil filler-plug. Tighten the plug firmly by hand. Do not overtighten.

3.6 Electrical installation: single-phase pumps

Note: If you have a bare shaft pump read section 9 before continuing. Some parts of Section 3.6 will not be applicable, depending on the type of motor fitted.

3.6.1 Check and configure the motor

CAUTION

Ensure that the motor is correctly configured for your electrical supply. If you operate the pump when the motor is not correctly configured for the electrical supply, you will damage the motor.

Refer to Figure 4 for the item numbers in brackets.

Ensure that the voltage shown on the voltage indicator (4) in the motor-cover corresponds with your electrical supply voltage. If it does not, you must change the configuration of the pump-motor to match your electrical supply voltage; use the procedure below.

1. Undo the four screws, remove the cover-plate (1) and lift out the voltage indicator moulding (4).
2. Press the voltage selector switch (3) to select the alternative position.
3. Turn the voltage indicator moulding over so that the outer panel shows the required voltage. Refit the moulding.

4. Refit the cover-plate and secure it with the four screws.

3.6.2 Connect the pump to your electrical supply

WARNING

Ensure that the electrical installation of the RV pump conforms with your local and national safety requirements. It must be connected to a suitably fused and protected electrical supply and a suitable earth point.

Notes: In the UK, if you use a 13 A plug, it must comply with BS1363A and be fitted with a 13 A fuse which complies with BS1362.

To prevent automatic restart of the pump-motor if the electrical supply is restored after an electrical supply failure, connect the pump to the electrical supply through suitable control equipment which must be reset manually after an electrical supply failure.

Make the electrical connections to the pump-motor with an IEC 320 cable socket (cold condition type) that satisfies your local electrical standards.

To maintain compliance with CSA standards, you must only use CSA/UL certified electrical supply cables and connectors. Cables must be SJT rated (minimum) and must incorporate an earth conductor. The conductors in the cable must be a minimum of 18 AWG.

If your RV pump was supplied with an electrical supply cable, the cable will be fitted with a moulded IEC connector at one end. The other end of the cable may be fitted with a plug suitable for your local electrical supply. A cable without a plug will contain wires colour coded as follows:

Green and yellow	earth
Blue	neutral
Brown	live

1. Ensure that the on/off switch on the motor (Figure 4, item 5) is in the 'off' position.
2. Insert the moulded IEC connector at the end of the cable into the electrical inlet-connector on the motor (Figure 4, item 2).
3. Connect the plug (if fitted) at the other end of the cable to your electrical supply. If a plug is not fitted, connect the wires in the cable to the correct terminals of your electrical supply.

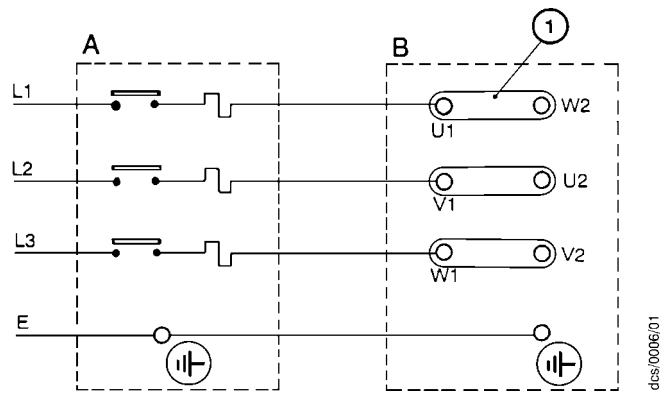

- A Starter/contactor
 B Motor terminal-box
1. Links

Figure 5 - Three-phase electrical connections: 200-230 V

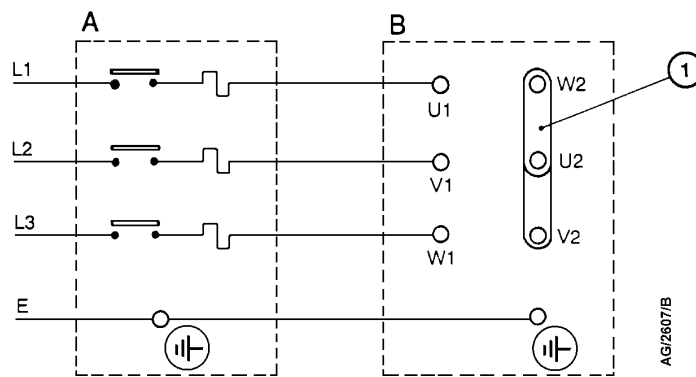

- A Starter/contactor
 B Motor terminal-box
1. Links

Figure 6 - Three-phase electrical connections: 380-460 V

3.6.3 Check the direction of rotation

CAUTION

Ensure that the pump-motor rotates in the correct direction. If it does not, the pump and your vacuum system can become pressurised.

Refer to Figure 1 for the item numbers in brackets.

1. Watch the motor cooling-fan through the motor fan-cover (13).
2. Use the on/off switch (12) to switch-on the electrical supply to the motor for a few seconds.
3. Check that the motor cooling-fan rotates in the correct direction (14) shown by the arrow on the motor fan-cover. If the direction of rotation is incorrect, switch off the electrical supply immediately and contact your supplier or Edwards for advice.

3.7 Electrical installation: three-phase pumps

3.7.1 Check and configure the motor

CAUTION

Ensure that the motor is correctly configured for your electrical supply. If you operate the pump when the motor is not correctly configured for the electrical supply, you will damage the motor.

1. Remove the screws which secure the cover of the motor terminal-box. Remove the cover.
2. Remove the cable-gland from the inside of the terminal-box and fit the cable-gland to the cable leadthrough hole in the side of the terminal-box.
3. Ensure that the motor is correctly configured for your electrical supply. If necessary, reconfigure the links (Figures 5 and 6, item 1) to suit your electrical supply:
 - For 200-230 V electrical supplies, the links must be configured as shown in Figure 5.
 - For 380-460 V electrical supplies, the links must be configured as shown in Figure 6.

3.7.2 Connect the pump to your electrical supply

WARNING

Ensure that the electrical installation of the RV pump conforms with your local and national safety requirements. It must be connected to a suitably fused and protected electrical supply and a suitable earth point.

Notes: To prevent automatic restart of the pump-motor if the electrical supply is restored after an electrical supply failure, connect the pump to the electrical supply through suitable control equipment which must be reset manually after an electrical supply failure.

To maintain compliance with CSA (Canadian Standards Association) standards, you must incorporate a switch or circuit breaker in the pump electrical supply. The switch or circuit breaker must be close to the pump and easily accessible, and must be clearly marked to identify that it is the electrical supply disconnection device for the pump.

We recommend that you connect the electrical supply to the motor through a starter or circuit breaker which has thermal over-current protection which can be adjusted to suit the full load current ratings shown in Table 4. The fuse ratings in Table 4 are provided for guidance only. The supplier of your thermal over-current protection device may specify different values to ensure correct operation of the fuse and the over-current protection device. Ensure that the fuse you use is suitable for the starting currents given in Table 4.

1. Pass the electrical supply cable through the cable-gland. The diameter of the electrical supply cable should be in the range 7 to 11 mm.
2. Use insulated crimped connectors to connect the wires in the cable to the terminals U1, V1 and W1 in the terminal-box as shown in Figures 5 and 6.
3. Ensure that the cover gasket is correctly positioned, then refit the cover to the terminal-box and secure with the screws. Tighten the strain-relief nut on the cable-gland.

3.7.3 Check the direction of rotation

CAUTION

Ensure that the pump-motor rotates in the correct direction. If it does not, the pump and your vacuum system can become pressurised.

1. Refer to Figure 1. Watch the motor cooling-fan through the motor fan-cover (13).
2. Switch-on the electrical supply to the motor for a few seconds.
3. Check that the motor cooling-fan rotates in the correct direction shown by the arrow on the motor mounting plate. If the direction of rotation is incorrect:
 - Switch off the electrical supply immediately.
 - Isolate the pump from the electrical supply.

- Remove the terminal-box cover and swap wires L1 and L3: see Figures 5 and 6.
- Refit the cover to the terminal-box.

3.8 Inlet and outlet connections

WARNING

Connect the exhaust to a suitable treatment plant to prevent the discharge of dangerous gases and vapours to the surrounding atmosphere. Use a catchpot to prevent the drainage of contaminated condensate back into the pump.

Before you connect the pump to your vacuum system, fit the centring-ring and inlet-filter (supplied with the pump) to the pump inlet-port (see Figure 5).

Take note of the following information when you connect the pump to your vacuum system. Refer to Section 7 for details of the accessories mentioned below. Use standard NW25 fittings (not supplied) when you connect the pump.

- For optimum pumping speeds, ensure that the pipeline connected to the pump-inlet is as short as possible and has an internal diameter of 25 mm or larger.
- Support the vacuum pipelines to prevent loading of the coupling-joints.
- If necessary, incorporate flexible bellows in your system pipelines to reduce the transmission of vibration and to prevent loading of coupling-joints. If you use flexible bellows, you must ensure that you use bellows which have a maximum pressure rating which is greater than the highest pressure that can be generated in your system. We recommend that you use Edwards flexible bellows.
- Use a suitable inlet trap if you pump condensable vapours or if you use the pump for very dusty applications.
- Use a suitable valve to isolate the pump from your vacuum system if you need to pump condensable vapours or maintain vacuum when the pump is switched off.
- Ensure that sealing surfaces are clean and scratch-free.

3.9 Leak-test the system

Leak-test the system and seal any leaks found after you have installed the RV pump, to prevent leakage of substances out of the system and leakage of air into the system.

3.10 Electrical installation

3.10.1 Check and configure the motor

CAUTION

If you operate the pump and the motor is not correctly configured for your electrical supply, you may damage the motor.

Before you connect the pump to the electrical supply, check the plug rating plate on the motor and ensure that the motor is suitable for use with your electrical supply. If the motor is multi-voltage, ensure that the motor is correctly configured for your electrical supply voltage and frequency; refer to the manufacturers information supplied with the motor.

3.10.2 Connect the motor to the electrical supply

WARNING

Ensure that the electrical installation of the pump conforms with your local and national safety requirements. It must be connected to a suitably fused and protected electrical supply and a suitable earth point.

Connect the motor to the electrical supply as specified in the manufacturers information supplied with the motor. Note also the following points:-

- You must use a suitable electrical supply cable.
- Connect the electrical supply to the motor through a starter or circuit breaker which has thermal over current protection which can be set to suit the full load current rating for the motor; refer to the manufacturers information supplied with the motor and to the electrical data in the manual and ensure that the fuse is suitable for the starting current for the motor.
- *In the U.K. If the motor is single phase and has built in over current or thermal protection, you may use a 13A plug to connect the motor to the electrical supply. The plug must conform to BS1363A and be fitted with a 13A fuse which complies with BS1362.*
- *We recommend that you connect the motor to the electrical supply through suitable control equipment which must be reset manually after an electrical supply failure. If you do not the pump will restart when the supply is restored.*

3.11 Check the direction of rotation

CAUTION

Ensure that the motor rotates in the correct direction. If it does not the pump and vacuum system will be pressurised. Do not connect the pump to the vacuum system when carrying out these tests.

1. Correct direction of rotation is anti clockwise when looking on the motor fan.
2. Watch the motor fan, switch on the supply to the motor for a few seconds, then switch off.
3. If the direction of rotation is incorrect, isolate the motor from the supply and reconfigure the electrical connections to the motor; refer to the manufacturer's information supplied with the motor.
4. Repeat the above check to ensure the direction of rotation is correct.

4 OPERATION

4.1 ATEX directive implications

4.1.1 Introduction

This equipment is designed to meet the requirements of Group II Category 3 equipment in accordance with Directive 94/9/EC of the European Parliament and the Council of 23rd March 1994 on the approximation of the laws of the Member States concerning equipment and protective systems intended for use in potentially explosive atmospheres. (The ATEX Directive)

The ATEX Category 3 applies in respect of potential ignition sources internal to the equipment. An ATEX Category has not been assigned in respect of potential ignition sources on the outside of the equipment as the equipment has not been designed for use where there is an external potentially explosive atmosphere.

There is no potential source of ignition within the pump during normal operation but there may be potential sources of ignition under conditions of predicted and rare malfunction as defined in the Directive. Accordingly, although the pump is designed to pump flammable materials and mixtures, operating procedures should ensure that under all normal and reasonably predicted conditions, these materials and mixtures are not within explosive limits. Category 3 is considered appropriate for the avoidance of ignition in the case of a rare malfunction which allows flammable materials or mixtures to pass through the pump while within their explosive limits.

4.1.2 Flammable/pyrophoric materials

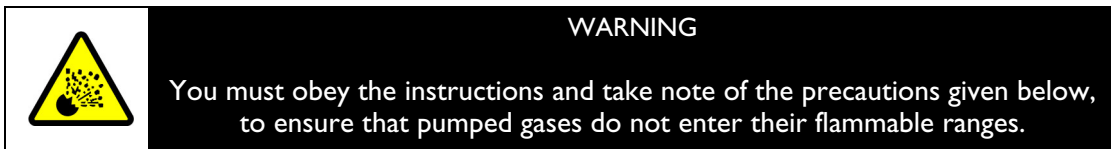

When flammable or pyrophoric materials are present within the equipment you must:

- Not allow air to enter the equipment.
- Ensure the system is leak tight.
- Use an inert gas purge (for example, a nitrogen purge) to dilute any flammable gases or vapours entering the pump inlet, and/or use an inert gas purge to reduce the concentration of flammable gases or vapours in the pump and in the exhaust pipeline to less than one quarter of the gases' published lower explosive limits (LEL).
- Use an inert gas purge in to the pump gas ballast connection to prevent the condensation of flammable vapours within the pump mechanism and exhaust pipeline.

4.1.3 Gas purges

	<p style="text-align: center;">WARNING</p> <p>If you use inert gas purges to dilute dangerous gases to a safe level, ensure that the RV3, RV5, RV8 and RV12 rotary vane pump is shut down if an inert gas supply fails.</p>
---	--

	<p style="text-align: center;">WARNING</p> <p>You must obey the instructions and take note of the precautions given below, to ensure that pumped gases do not enter their flammable ranges.</p>
---	--

Switch on the inert gas purge to remove air from the pump and the exhaust pipeline before the process starts. Switch off the purge flow at the end of the process only after any remaining flammable gases or vapours have been purged from the pump and exhaust pipeline.

If liquids that produce flammable vapours could be present in the pump foreline, then the inert gas purge to the RV3, RV5, RV8 and RV12 rotary vane pump should be left on all the time this liquid is present. Flammable liquids could be present in the foreline as a result of condensation, or may be carried over from the process.

When you calculate the flow rate of inert gas required for dilution, consider the maximum flow rate for the flammable gases/vapours that could occur. For example, if a mass flow controller is used to supply flammable gases to the process, you should assume a flow rate for flammable gases that could arise if the mass flow controller is fully open.

Continually measure the inert gas purge flow rate: if the flow rate falls below that required, you must stop the flow of flammable gases or vapours into the pump.

Note: We recommend that you obtain and read the Vacuum Pump and Vacuum System Safety manual (publication number P300-20-000), available from BOC Edwards or your supplier.

4.2 How to use the pump controls

You can use the mode selector (Figure 1, item 11) and the gas-ballast control (Figure 1, item 5) to optimise the performance of the RV pump for your application. The performance characteristics of the pump with the different control settings are shown in Tables 1 and 2. You can change the position of both the mode selector and the gas-ballast control when the pump is off or when the pump is operating.

4.2.1 Mode selector

Note: The pump is supplied with High Vacuum mode ♠ selected. If High Vacuum mode is selected and you cannot turn the mode selector by hand to select the High Throughput mode, use a suitable tool fitted to the flat part of the mode selector to turn the selector.

The mode selector controls the flow of pressurised oil to the high vacuum stage of the pump (see Section 1.4.1). You can turn the mode selector to one of two positions, as follows:

To select the High Vacuum mode ♠, turn the mode selector fully clockwise and tighten by hand. When High Vacuum mode is selected, there is a gap of approximately 3 mm between the mode selector and the inner face of the side panel of the pump. Use this mode:

- to achieve ultimate vacuum
- to pump clean gases
- to pump clean condensable vapours.

To select the High Throughput mode ♡, turn the mode selector fully anticlockwise until it touches the inner face of the side panel of the pump, then gently tighten by hand. Use this mode:

- for long-term operation with high gas throughput (that is, inlet pressure > 50 mbar)
- to pump dirty condensable vapours
- to decontaminate the oil.

4.2.2 Gas-ballast control

Use the gas-ballast control to change the amount of air (or inert gas) introduced into the low vacuum stage of the pump (refer to Section 1.4.2). Use of gas-ballast will prevent the condensation of vapours in the pump; the condensates would contaminate the oil. You can turn the gas-ballast control to select one of three positions, as follows:

To select gas-ballast closed, turn the control to position '0'. Use this setting:

- to achieve ultimate vacuum
- to pump dry gases.

To select low flow gas-ballast, turn the control to position 'I'. Use this setting:

- to pump low concentrations of condensable vapours
- to decontaminate the oil.

To select high flow gas-ballast, turn the control to position 'II'. Use this setting:

- to pump high concentrations of condensable vapours.



When you use either low flow or high flow gas-ballast, there will be an increased rate of oil loss from the pump. Where possible, we recommend that you select low flow gas-ballast (position 'I') rather than high flow gas-ballast (position 'II') to minimise the loss of oil.

4.3 Start-up procedure

WARNING

Ensure that your system design does not allow the exhaust pipeline to be blocked.

If the oil is contaminated, or if the pump temperature is below 12 °C, or if the electrical supply voltage is more than 10% below the lowest voltage specified on the voltage indicator (Figure 4, item 4), the pump may operate at a reduced speed for a few minutes. On single-phase pumps, if the pump continues to operate at reduced speed, the motor thermal overload device will open and stop the pump. When the motor has cooled, the thermal overload device will reset automatically and the pump will restart.

1. Check that the pump oil-level is between the MAX and MIN marks on the bezel of the oil-level sight-glass; if it is not, refer to Section 5.3.
2. Turn the mode selector fully clockwise to select High Vacuum mode  or fully anticlockwise to select High Throughput mode , as required (refer to Section 4.2.1).
3. Turn the gas-ballast control to position '0', 'I' or 'II', as required (refer to Section 4.2.2).
4. Switch on the electrical supply to the pump; on single-phase pumps, use the on/off switch.
5. If you want to achieve ultimate vacuum, to pump condensable vapours or to decontaminate the pump oil, refer to the procedures in Sections 4.4, 4.5 and 4.6 respectively. Otherwise, open the vacuum system isolation-valve.

4.4 To achieve ultimate vacuum

If the pump does not achieve the performance specified in Section 2, make sure that this is not due to your system design before you contact your supplier or Edwards for advice. In particular, the vapour pressure of all materials used in your vacuum system (including pump oil, see below) must be much lower than the specified ultimate vacuum of the pump. Refer to Section 5.12.2 for a list of possible causes for failure to achieve the specified performance; note however that the most common causes are:

- Your pressure measurement technique or gauge head is unsuitable or the gauge head is faulty.
- You have used an oil other than the recommended oil, and the vapour pressure of the oil is higher than the specified ultimate vacuum of the pump.

Use the following procedure to achieve ultimate vacuum:

1. Isolate the RV pump from your vacuum system.
2. Turn the mode selector to select High Throughput mode **◆**, set the gas-ballast control to low flow (position 'I') and operate the pump for at least 1 hour (or overnight) to thoroughly purge the oil of contaminants.
3. Turn the mode selector to select High Vacuum mode **◆** and close the gas-ballast control (that is, set it to position '0').
4. Open the vacuum system isolation-valve and pump down to ultimate vacuum.

4.5 To pump condensable vapours

Use gas-ballast (gas-ballast control in position 'I' or 'II') when there is a high proportion of condensable vapours in the process gases.

1. Close the vacuum system isolation-valve.
2. Turn the mode selector fully clockwise to select High Vacuum mode **◆** or fully anticlockwise to select High Throughput mode **◆**, as required (refer to Section 4.2.1).
3. Turn the gas-ballast control to high flow (position 'II') and operate the pump for 30 minutes to warm the oil; this will help to prevent vapour condensation in the pump.
4. Set the gas-ballast control to the position required for your application (refer to Section 4.2.2 and the data in Tables 1 and 2).
5. Open the vacuum system isolation-valve.

After you have pumped condensable vapours, you can (if necessary) decontaminate the oil: use the procedure in Section 4.6.

4.6 To decontaminate the oil

The oil in the pump should be clear; if the oil is cloudy or discoloured, it is contaminated with process vapours.

1. Look at the condition of the oil in the oil-level sight-glass (Figure 1, item 8). If the oil is cloudy or discoloured, continue with the procedure at Step 2 below.
2. Close the vacuum system isolation-valve.
3. Turn the mode selector fully anticlockwise to select High Throughput mode **◆**. Set the gas-ballast control to low flow (position 'I').
4. Operate the pump until the oil is clear.

4.7 Unattended operation

The RV pump is designed for unattended operation under the normal operating conditions specified in Section 2. However, we recommend that you check the pump at regular intervals of not more than 14 days, or more frequently if you pump high volumes of gas or vapour.

On single-phase pumps, the motor is protected by an overload device which isolates the pump from the electrical supply when critical temperature or current levels are exceeded. The overload device resets automatically when the motor has cooled. When you check the pump, make sure that the pump is not going through a repetitive cycle of thermal overload failures and automatic resets. If necessary, change the mode selector to High Throughput mode  and reduce the thermal load from the pumped gases, to prevent overheating of the pump.

4.8 Shut-down

We recommend, as described in the procedure below, that you decontaminate the oil before you shut down the pump; this will prevent damage to the pump by the contaminants in the oil.

1. Refer to Section 4.6 and decontaminate the oil, as required.
2. Close the vacuum system isolation-valve (if not already closed).
3. Close gas-ballast (that is, set the gas-ballast control to position '0').
4. On single-phase pumps, use the on/off switch to switch off the pump.
5. Switch off the electrical supply to the pump.

5 MAINTENANCE

5.1 Safety information

WARNING

Obey the safety instructions given below and take note of appropriate precautions. If you do not, you can cause injury to people and damage to equipment.

- If your pump is PFPE prepared, refer to Section 8.
- Ensure that maintenance is done by a suitably trained and supervised technician. Obey your local and national safety requirements.
- Ensure that the maintenance technician is familiar with the safety procedures which relate to the pump-oil and the products processed by the pumping system.
- Check that all the required parts are available and of the correct type before you start work.
- Isolate the pump and other components from the electrical supply so that they cannot be operated accidentally.
- Allow the pump to cool (so that it is at a safe temperature for skin contact) before you start maintenance work. Make sure the pump is switched off in case the thermal overload device restarts the pump.
- Do not reuse 'O' rings and seals if they are damaged.
- After maintenance is completed, recheck the direction of pump rotation if the electrical supply has been disconnected.
- The pump and the pump-oil will be contaminated with the process chemicals that have been pumped during operation. Ensure that the pump is decontaminated before maintenance and that you take adequate precautions to protect people from the effects of dangerous substances if contamination has occurred.

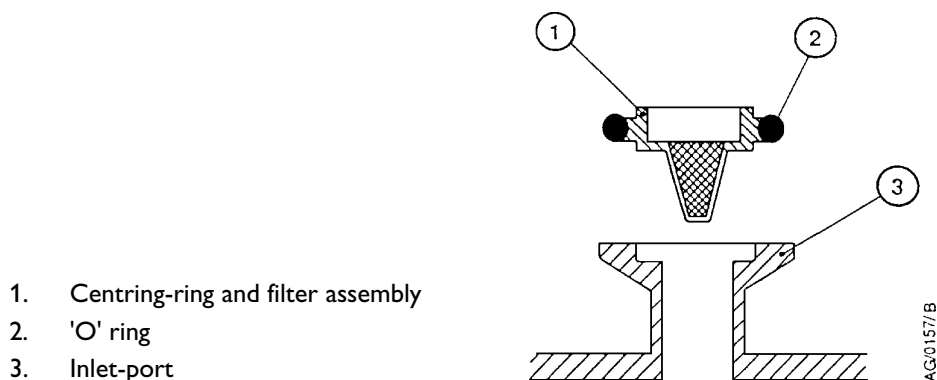

Figure 7 - Inlet-filter assembly

- Do not touch or inhale the thermal breakdown products of fluorinated materials which may be present if the pump has been heated to 310 °C and above. Fluorinated materials are safe in normal use but can decompose into very dangerous substances (which may include hydrofluoric acid) if they are heated to 310 °C and above. The pump may have overheated if it was misused or if it was in a fire. Health and Safety Data sheets for fluorinated materials used in the pump are available on request: contact your supplier or Edwards.
- If necessary, maintain the motor as specified in the manufacturers information supplied with the motor.

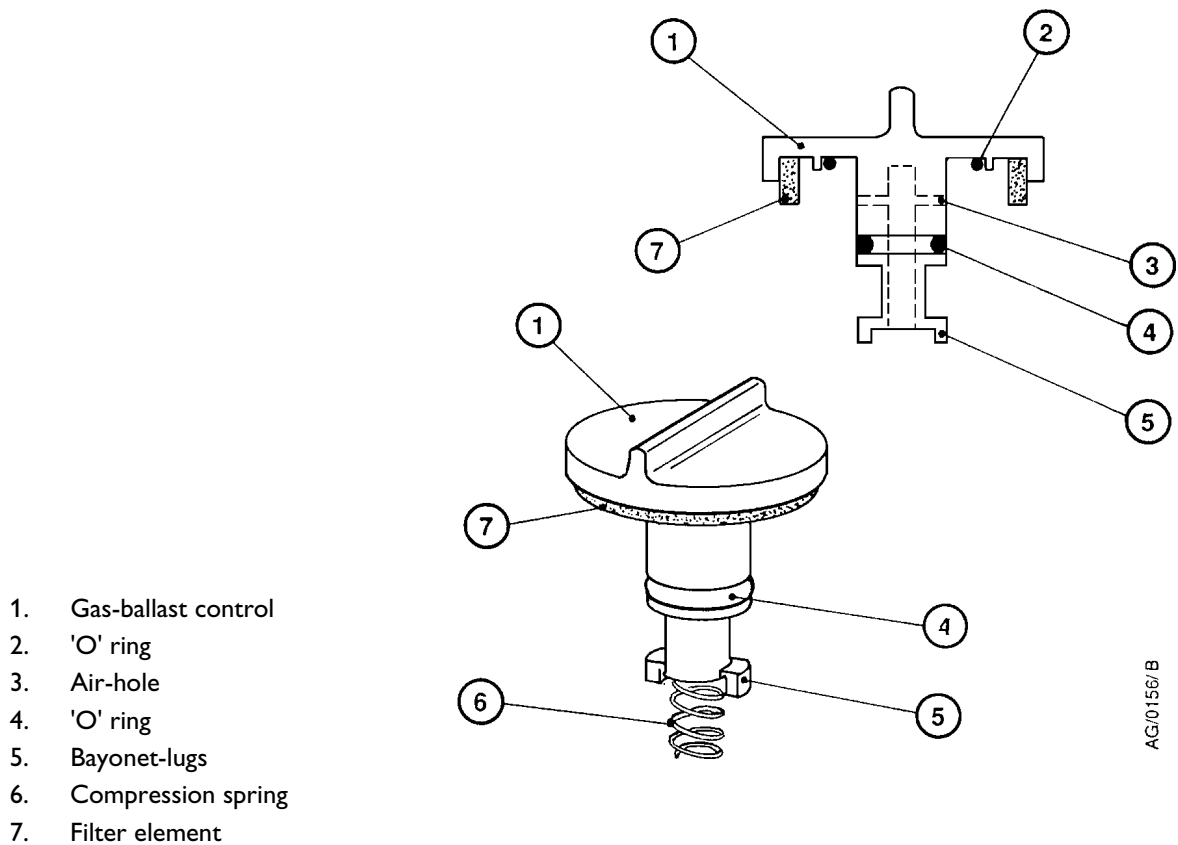

Figure 8 - Gas-ballast control assembly

5.2 Maintenance plan

The plan shown in Table 7 details the routine maintenance operations necessary to maintain RV pumps in normal use. Instructions for each operation are given in the section shown.

Operation	Frequency	Refer to Section
Check the oil-level	Monthly	5.3
Replace the oil	Every 3000 hours	5.4
Inspect and clean the inlet-filter	Yearly	5.5
Inspect and clean the gas-ballast control	Yearly	5.6
Clean the oil-level sight-glass	Yearly	5.7
Clean the motor fan-cover and enclosure	Yearly	5.8
Clean and overhaul the pump	Every 15000 hours	5.9
Fit new blades	Every 30000 hours	5.10
Test the motor condition	Every 15000 hours	5.11

Table 7 - Maintenance plan

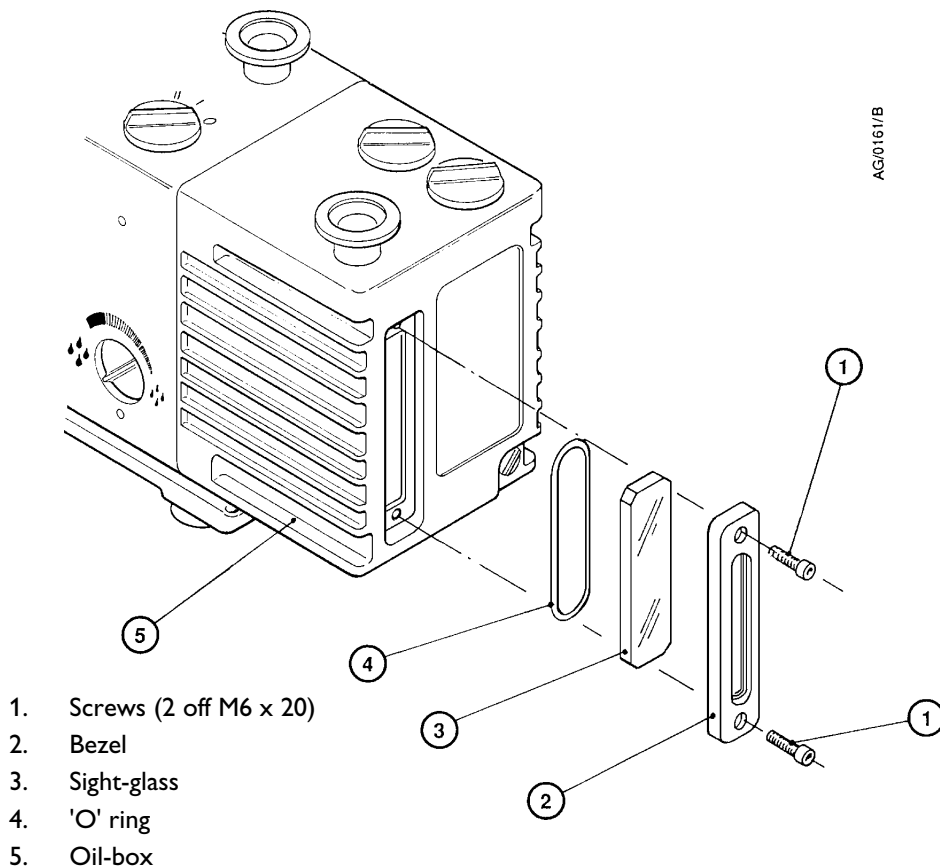

Figure 9 - Sight-glass assembly

More frequent maintenance may be required if the pump is used to pump corrosive or abrasive gases and vapours, such as solvents, organic substances and acids; in these circumstances, we recommend that you replace the pump seals every year (refer to Section 7 for details of available spares). If necessary, adjust the maintenance plan according to your experience.

When you maintain the RV pump, use Edwards spares and maintenance kits; these contain all of the components necessary to complete maintenance operations successfully. The Item Numbers of the spares and kits are given in Section 7.

5.3 Check the oil-level

Note: If required, you can check the oil-level while the pump is operating, however you must switch off the pump and isolate the pump and other components in the pumping system from the electrical supply before you pour oil into the pump.

Refer to Figure 1 for the items in brackets.

1. Check that the oil-level in the sight-glass (8) is between the MAX and MIN level marks on the bezel of the sight-glass.
2. If the oil-level is near to or below the MIN level mark, remove one of the filler-plugs (6) and pour more oil into the reservoir until the oil reaches the MAX level mark. If the oil-level goes above the MAX mark, remove the drain-plug (9) and drain the excess oil from the pump. Refit the filler-plug.
3. If the oil is contaminated, drain and refill the pump with clean oil as described in Section 5.4.

5.4 Replace the oil

1. Refer to Figure 1. Operate the pump for approximately ten minutes to warm the oil, then switch off the pump (this lowers the viscosity of the oil and enables it to be drained from the pump more easily).
2. Isolate the pump from your electrical supply and disconnect it from your vacuum system.
3. Remove one of the oil filler-plugs (6).
4. Place a suitable block under the pump-motor to tilt the pump and place a suitable container under the drain-plug (9). Remove the drain-plug and allow the oil to drain into the container.
5. If the oil drained from the pump is contaminated, pour clean oil into the filler-hole and allow it to drain out of the pump. Repeat this step until the oil reservoir in the pump has been thoroughly cleaned.
6. Refit the drain-plug, remove the block and reconnect the pump to your vacuum system.
7. Fill a suitable container with clean oil and pour the oil into the filler hole until the oil-level reaches the MAX level mark on the bezel of the sight-glass (8).
8. Allow a few minutes for the oil to drain into the pump. If necessary, add more oil. Refit the filler-plug.

5.5 Inspect and clean the inlet-filter

1. Refer to Figure 8. Disconnect your vacuum system from the pump inlet-port (3) and remove the centring-ring and filter assembly (1) and the 'O' ring (2). Inspect the centring-ring and the 'O' ring. If they are clean, continue at Step 5. If they are not clean, continue at Step 2.
2. Remove the 'O' ring (2) from the centring-ring and filter assembly (1). Do not allow the 'O' ring to come into contact with the cleaning solution.
3. Wash the centring-ring and filter assembly in a suitable cleaning solution and allow it to dry.
4. If necessary, wipe the 'O' ring with a clean, dry, lint-free cloth.
5. Refit the centring-ring and filter assembly and the 'O' ring to the inlet-port. Refit your vacuum system to the pump inlet-port.

5.6 Inspect and clean the gas-ballast control

Note: The gas-ballast filter element (Figure 8, item 7) is retained in its seating with adhesive; do not try to remove it.

1. Refer to Figure 8. Turn the gas-ballast control (1) to the high flow position (position 'II').
2. Push the control down against the compression spring (6) as far as it will go, then turn the control anticlockwise slightly to release the bayonet-lugs (5) and remove the control.
3. If necessary, wipe the control with a clean, dry, lint-free cloth and check that the air-hole (3) is not blocked.
4. Refit the control into the gas-ballast inlet and ensure that the compression spring locates correctly between the bayonet-lugs.
5. Push the control down as far as it will go and then turn the control clockwise slightly until the bayonet-lugs engage correctly.
6. Reset the gas-ballast control to the required position.

5.7 Clean the oil-level sight-glass

Refer to Figure 9 for the item numbers in brackets.

1. Drain the oil as described in Section 5.4.
2. Undo the two screws (1) and remove the bezel (2), the sight-glass (3) and the 'O' ring (4) from the oil-box (5).
3. Clean the screws, bezel and sight-glass with a suitable cleaning solution.
4. Wipe the 'O' ring with a clean, dry, lint-free cloth.
5. Wipe the sight-glass recess in the oil-box with the cloth.

6. Refit the 'O' ring, sight-glass and bezel and secure with the two screws.
7. Refill the pump with oil as described in Section 5.4.
8. Check that the sight-glass does not leak.

5.8 Clean the motor fan-cover and enclosure

If the motor fan-cover and enclosure are not kept clean, the air-flow over the motor can be restricted and the pump may overheat.

1. Switch off the pump and disconnect it from the electrical supply.
2. Use a dry cloth and a soft brush to remove dirt and deposits from the fan-cover and enclosure.

5.9 Clean and overhaul the pump

Clean and overhaul the pump as described in the instructions supplied with the clean and overhaul kit (see Section 7).

5.10 Fit new blades

Fit new blades to the pump as described in the instructions supplied with the blade kit (see Section 7).

5.11 Test the motor condition

Test the earth continuity and the insulation resistance of the pump-motor, in accordance with local regulations for periodic testing of electrical equipment.

The motor of single-phase RV pumps complies with IEC 1010-1. We recommend that, to maintain compliance with IEC 1010-1, the earth continuity is less than 0.1 Ω and the insulation resistance is greater than 10 MW.

If the motor fails these tests, you must replace the motor.

5.12 Fault-finding

A list of fault conditions and their possible causes is provided here to assist you in fault-finding. If you are unable to rectify a fault when you use this guide, call your nearest Edwards Service Centre for help.

5.12.1 The pump has failed to start

- The electrical supply fuse has blown

- The electrical supply voltage does not match that of the motor
- The outlet pipeline or the outlet-filter (if fitted) is blocked
- The oil temperature is below 12 °C
- The oil is too viscous
- The oil is contaminated
- The pump has seized after long storage
- The pump has been left to stand after contaminants have been pumped and has seized
- The motor is faulty.

5.12.2 The pump has failed to achieve the specified performance (has failed to reach ultimate vacuum)

- Your pressure measurement technique or gauge head is unsuitable or gives an incorrect indication of pressure. For example, a contaminated Pirani gauge can indicate a pressure which is several times higher than the actual pressure in the system.
- You have filled the pump with the wrong type of oil
- There is a leak in your vacuum system
- The mode selector and gas-ballast control are set incorrectly
- The oil-level is below minimum level
- The oil is contaminated
- Your vacuum fittings are dirty or damaged
- The inlet-filter is blocked
- The pump has not warmed up.

5.12.3 The pump is noisy

- The motor fan-cover is damaged
- The motor bearings are worn
- The oil is contaminated with solid particles.

5.12.4 The pump surface temperature is above 100 °C

Note: If the inlet pressure is continuously higher than 100 mbar (1×10^4 Pa), the surface temperature of the RV12 pump can reach 115 °C when the ambient temperature is 40 °C.

- The ambient temperature is too high

- The cooling-air supply is insufficient or is too hot
- The electrical supply voltage is too high
- The outlet-filter or the outlet pipeline is blocked
- The oil-level is below minimum level
- You have filled the pump with the wrong type of oil
- The oil is contaminated
- The process gas is too hot or the throughput is too high.

5.12.5 The vacuum is not fully maintained after the pump is switched off

- The gas-ballast control is open (that is, in position 'I' or 'II')
- The inlet valve-pad is damaged
- The inlet valve has not closed.

5.12.6 The pumping speed is poor

- The connecting pipelines are too small in diameter
- The connecting pipelines are too long
- The inlet-filter is blocked.

5.12.7 There is an external oil leak

- The outer shaft-seal is worn or damaged
- The oil-box gaskets have deteriorated
- There is an oil leak from the gas-ballast control
- There is an oil leak from the drain-plug
- There is an oil leak from the sight-glass

6 STORAGE AND DISPOSAL

6.1 Storage

CAUTION

Observe the storage temperature limits stated in Section 2. Storage below -30 °C will permanently damage the pump seals.

Note: If you will store a new pump in conditions of high humidity, remove the pump from its cardboard packaging box; dispose of the box (refer to Section 6.2).

Use the following procedure to store the pump:

1. Shut-down the pump as described in Section 4.
2. Disconnect the pump from the electrical supply.
3. Purge your vacuum system and the pump with dry nitrogen and disconnect the pump from your vacuum system.
4. Replace the oil as described in Section 5.4.
5. Place and secure protective covers over the inlet and outlet-ports.
6. Store the pump in cool, dry conditions until required for use. When required, prepare and install the pump as described in Section 3. If the pump has been stored for more than a year, before you install the pump you must clean and overhaul it as described in the instructions supplied with the clean and overhaul kit.

6.2 Disposal

Dispose of the pump and any components removed from it safely in accordance with all local and national safety and environmental requirements.

Particular care must be taken with components and waste oil which have been contaminated with dangerous process substances.

Do not incinerate fluoroelastomer seals and 'O' rings.

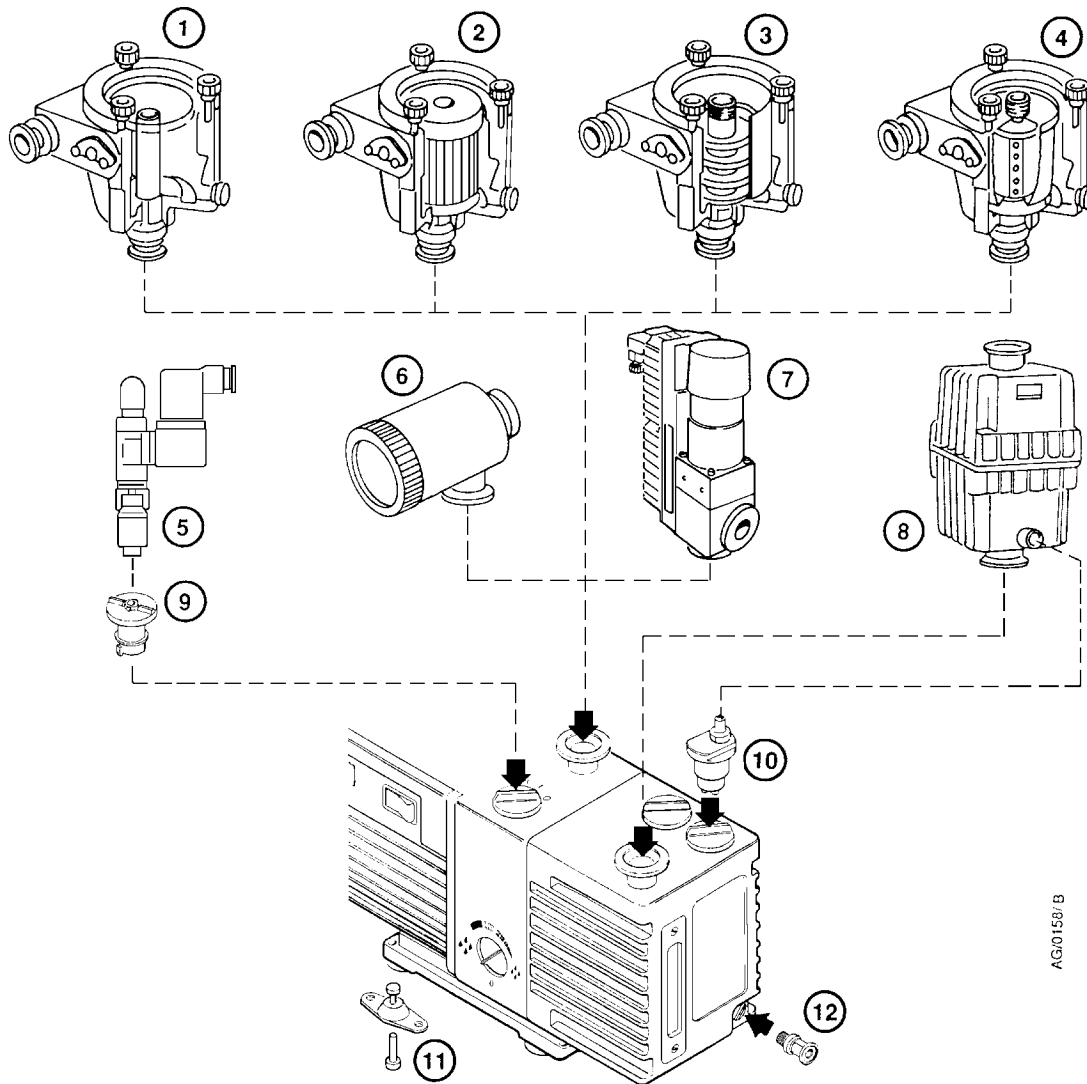

AG0158/B

- | | |
|--|-------------------------------------|
| 1. Inlet catchpot | 7. Solenoid operated pipeline valve |
| 2. Inlet dust filter | 8. Outlet mist filter |
| 3. Inlet desiccant trap | 9. Gas-ballast adaptor |
| 4. Inlet chemical trap | 10. Gravity oil drain kit |
| 5. Solenoid operated gas-ballast valve | 11. Vibration isolators |
| 6. Foreline trap | 12. Oil drain-extension |

Figure 10 - Accessories

7 SERVICE, SPARES AND ACCESSORIES

7.1 Introduction

Edwards products, spares and accessories are available from Edwards companies in Belgium, Brazil, Canada, France, Germany, Hong Kong, Italy, Japan, Korea, Switzerland, United Kingdom, U.S.A and a world-wide network of distributors. The majority of these centres employ Service Engineers who have undergone comprehensive Edwards training courses.

Order spare parts and accessories from your nearest Edwards company or distributor. When you order, state for each part required:

- Model and Item Number of your equipment
- Serial number
- Item Number and description of part.

7.2 Service

Edwards products are supported by a world-wide network of Edwards Service Centres. Each Service Centre offers a wide range of options including: equipment decontamination; service exchange; repair; rebuild and testing to factory specifications. Equipment which has been serviced, repaired or rebuilt is returned with a full warranty.

Your local Service Centre can also provide Edwards engineers to support on-site maintenance, service or repair of your equipment.

For more information about service options, contact your nearest Service Centre or other Edwards company.

7.3 Spares

Product	Hydrocarbon Variants Part Number	PFPE Variants Part Number
Edwards oil	1L Ultragrade 19 H110-25-015	(1kg) Fomblin 06/6 H113-06-019
Edwards oil	4L Ultragrade 19 H110-25-013	(5kg) Fomblin 06/6 H113-06-020
Clean and overhaul kit (Standard)	A652-01-131	A652-01-131
RV3 Blade kit	A652-01-130	A652-01-130
RV5 Blade kit	A653-01-130	A653-01-130
RV8 Blade kit	A654-01-130	A654-01-130
RV12 Blade kit	A655-01-130	A655-01-130
RV3 Cartridge Kit	A652-01-032	A652-09-032
RV5 Cartridge Kit	A653-01-032	A653-09-032
RV8 Cartridge Kit	A654-01-032	A654-09-032
RV12 Cartridge Kit	A655-01-032	A655-09-032
Inlet-valve kit	A652-01-036	A652-01-036
Motor Starting Relay Kit	A505-74-000	A505-74-000
Outer Shaft-Seal Kit	A652-01-134	A652-01-134
Rotor Sleeve Kit	A652-01-136	A652-09-136
RV3/RV5 Motor Kit (Europe/USA) 50/60 Hz, 250/300 W, 1 phase, 110-120/220-240 V	A652-99-000	A652-99-000
RV8/RV12 Motor Kit (Europe/USA) 50/60 Hz, 450/550 W, 1 phase, 110-120/220-240 V	A654-99-000	A654-99-000
RV3/RV5 Motor Kit (Japan) 50/60 Hz, 250/300 W, 1 phase, 100/200 V	A652-98-000	A652-98-000
RV8/RV12 Motor Kit (Japan) 50/60 Hz, 450/550 W, 1 phase, 100/200 V	A654-98-000	A654-98-000
RV3/RV5 Motor Kit (Europe/USA/Japan) 50/60 Hz, 250/300 W, 3 phase, 200-230/380-460 V	A652-97-000	A652-97-000
RV8/RV12 Motor Kit (Europe/USA/Japan) 50/60 Hz, 450/550 W, 3 phase, 200-230/380-460 V	A654-97-000	A654-97-000
Clean and Overhaul Kit (Nitrile)	A652-01-137	

Table 8 - Spares and Accessories

7.4 Accessories

Figure 11 shows the accessories which can be fitted to an RV pump.

7.4.1 Inlet catchpot

The inlet catchpot traps any liquid droplets and prevents their entry into the pump.

Product	Item Number
ITO20K Inlet catchpot	A441-10-000

7.4.2 Inlet dust filter

The inlet dust filter protects the pump against abrasive dust.

Product	Item Number
ITF20K Inlet dust filter	A442-15-000

7.4.3 Inlet desiccant trap

Use a desiccant trap when you pump limited quantities of water vapour at high pumping speeds to a low vapour pressure.

Product	Item Number
ITD20K Inlet desiccant trap	A445-10-000

7.4.4 Inlet chemical trap

The inlet chemical trap protects the pump against chemically active gases.

Product	Item Number
ITC20K Inlet chemical trap	A444-10-000

7.4.5 Solenoid operated gas-ballast valve

Fit the gas-ballast valve in place of the built-in gas-ballast control on the pump; you must fit the gas-ballast adaptor (see Section 7.4.9) with the solenoid operated gas-ballast valve. The valve provides automatic on/off control of the gas-ballast and isolates the gas-ballast inlet when the pump is switched off.

Product	Electrical supply	Item Number
EBV20 Valve	220-240 V 50/60 Hz	A500-06-930
EBV20 Valve	100-120 V 50/60 Hz	A500-06-984

7.4.6 Foreline trap

Use a foreline trap on a clean pumping system to prevent back-migration of pump-oil vapour into your vacuum system.

Product	Item Number
FL20K Foreline trap	A133-05-000

7.4.7 Solenoid operated pipeline valve

Fit the pipeline valve between your vacuum system and the pump-inlet to provide additional system protection when the pump is switched off.

Product	Electrical supply	Item Number	
		Aluminium	Stainless steel
PV25EK Valve	220-240 V 50/60 Hz	C413-01-000	C413-02-000
PV25EK Valve	110-127 V 50/60 Hz	C413-03-000	C413-04-000

7.4.8 Outlet mist filter

The outlet mist filter separates and traps oil droplets in the pump outlet to prevent oil mist discharge.

Product	Item Number
EMF10 Outlet mist filter	A462-26-000
EMF20 Outlet mist filter	A462-29-000

7.4.9 Gas-ballast adaptor

Fit the gas-ballast adaptor in place of the gas-ballast control on the pump. The adaptor allows you to fit a solenoid operated gas-ballast valve or a controlled supply of inert gas to the pump.

Product	Item Number
Gas-ballast adaptor	A505-02-000

7.4.10 Gravity oil drain kit

Fit the oil drain kit between the drain port of the outlet mist filter and the oil filler-plug on the pump. When the kit is fitted, oil will be returned from the mist filter to the pump when the pump is switched off or when the gas-ballast control is closed (in the '0' position) and there is no process gas being pumped.

Product	Item Number
Gravity oil drain kit	A505-01-000

7.4.11 Vibration isolators

Vibration isolators reduce vibration and noise when the pump is floor or frame mounted and help to reduce strain when the mounting area is uneven.

Product

Vibration isolators (pack of four)

Item Number

A248-01-404

7.4.12 Oil drain-extension

Fit the oil drain-extension between the oil drain port on the pump and the oil drain-plug to make the drainage of oil from the pump easier.

Product

Oil drain-extension

Item Number

A505-03-000

7.4.13 Exhaust nozzle kit

The exhaust nozzle replaces the outlet flange. Use the exhaust nozzle to connect the pump outlet to 12 mm internal diameter plastic hose.

Product

Exhaust nozzle kit

Item Number

A505-09-000

8 ROTARY VACUUM PUMP PREPARED FOR USES WITH PFPE OILS

8.1 Summary

WARNING

PFPE prepared pumps allow pumping of high concentrates of oxygen, but are not recommended for pumping hazardous materials.

The pump is prepared for use with BOC Edwards PFPE mechanical pump oils, (such as Fomblin YVAC 06/6 and Krytox 1506) and is intended for use when pumping high concentrates of oxygen.

CAUTION

Never use hydrocarbon lubricants in a PFPE prepared pump.

8.2 Installation

When you fill the pump with oil, use a suitable BOC Edwards PFPE oil. Ignore any further mention of BOC Edwards Oils stated in this manual.

8.3 Maintenance

WARNING

Do not touch the thermal breakdown products of fluorinated materials which may PFPE present if the pump has been heated to 260 °C and above. These breakdown products are very dangerous. Fluorinated materials in the pump include the seals, the RT15 grease and your oil.

CAUTION

Care must be taken after a pump malfunction, in case the oil has been overheated.

Note! Fomblin oil is difficult to seal, and it is advised that a regular check must be performed for oil leaks, especially round shaft seals.

8.4 System Safety

Refer to EHVI Publication No P300-20-0000. (Vacuum Pump & Vacuum System Safety)

9 BARE SHAFT PUMPS

9.1 Description

Two types of bare shaft pump are available;-

- To suit an IEC72-1 motor with an (IMB14) FT85 face mounting and 14 mm diameter shaft.
- To suit a NEMA 56C motor with a 5/8" diameter shaft.

The new motor must have an adequate power rating for use with the RV pump, refer to the pump electrical data section in the manual.

Note: Some of the standard performance specifications may vary, depending on the type of motor fitted.

9.2 Fit the new motor to the pump

Refer to Figure 11. Use the four screws (455) to fit the motor support (453) to the motor.

Use the two screws (422) to fit the lifting plate (413), then fit the lifting plate cover (414).

Fit the fan ducting sheet (409).

Ensure that key "B" is in place on the motor shaft, then push the fan (410) onto the shaft. Ensure that the end of the shaft aligns with the bottom of the cavity in the fan and that the back of the fan is 2,5 mm from the ducting sheet. Secure the fan to the shaft with the screw (454). Tighten the screw to a torque between 7 and 9 Nm.

Use a suitable lubricant on the coupling element (411) then fit the element to the coupling hub. Align the coupling element in the hub with the coupling in the fan and fit the motor to the pump. Secure the motor with the four screws (421). Tighten the screws to a torque of between 10 and 12 Nm. The gap between the coupling faces must be 2 mm or less; adjust the position of the coupling hub on the pump shaft to achieve this dimension.

■ Shown for reference only

A Pump motor
B Key (in shaft)

132 Coupling hub
409 Ducting sheet

410 Fan
411 Coupling element
413 Lifting plate
414 Lifting plate cover
421 Screw
454 Screw
453 Motor support
455 Screw

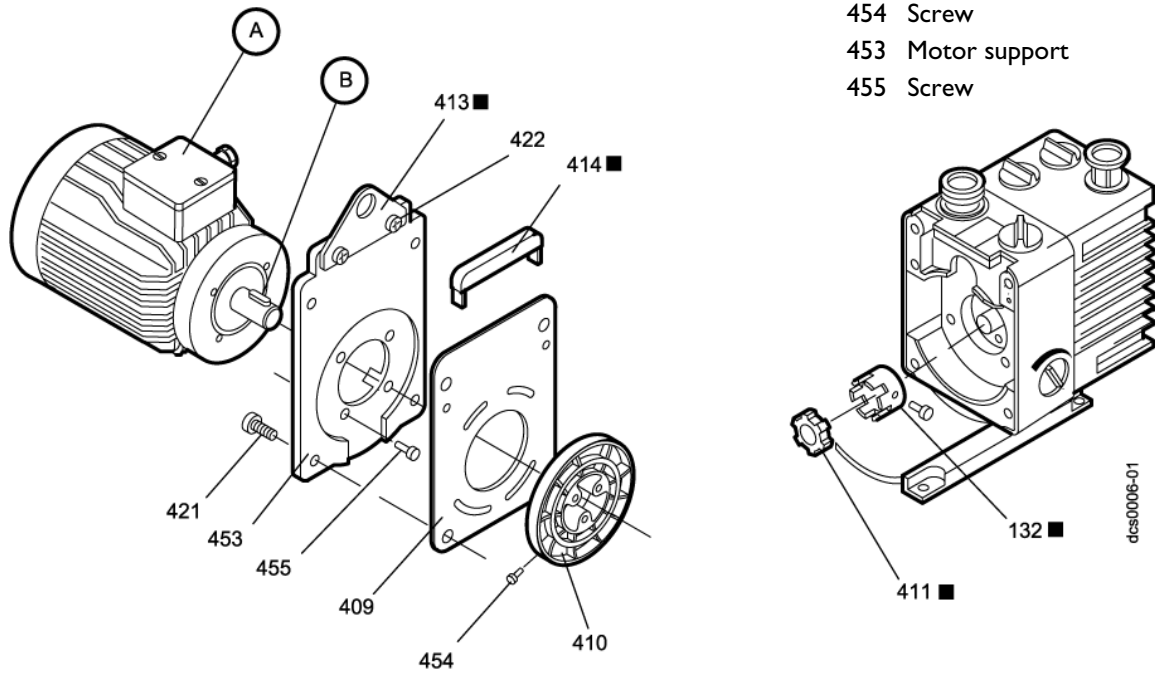

Figure 11 - Fit the new motor to the pump

In any of the following circumstances, we recommend that you fit an oil mist filter to the pump outlet:

- If you use the pump with the gas ballast control open (in position 'I' or position 'II').
- If you operate the pump with an inlet pressure greater than 10 mbar (1×10^3 Pa) for extended periods.
- If you frequently pump down from atmospheric pressure.

The oil mist filter will trap the oil exhausted from the pump; you can reuse the oil if it is not contaminated.

Return of BOC Edwards Equipment - Procedure

INTRODUCTION

Before returning your equipment, you must warn BOC Edwards if substances you used (and produced) in the equipment can be hazardous. This information is fundamental to the safety of our Service Centre employees and will determine the procedures employed to service your equipment.

Complete the Declaration (HS2) and send it to BOC Edwards before you dispatch the equipment. It is important to note that this declaration is for BOC Edwards internal use only, and has no relationship to local, national or international transportation safety or environmental requirements. As the person offering the equipment for shipment, it is your responsibility to ensure compliance with applicable laws.

GUIDELINES

- Equipment is '**uncontaminated**' if it has not been used, or if it has only been used with substances that are not hazardous. Your equipment is '**contaminated**' if it has been used with any substances classified as hazardous under EU Directive 67/548/EEC (as amended) or OSHA Occupational Safety (29 CFR 1910).
- If your equipment has been used with radioactive substances, biological or infectious agents, mercury, polychlorinated biphenyls (PCB's), dioxins or sodium azide, you must decontaminate it before you return it to BOC Edwards. You must send independent proof of decontamination (for example a certificate of analysis) to BOC Edwards with the Declaration (HS2). Phone BOC Edwards for advice.
- If your equipment is contaminated, you must either:
 - Remove all traces of contamination (to the satisfaction of laws governing the transportation of dangerous/hazardous substances).
 - Or, properly classify the hazard, mark, manifest and ship the equipment in accordance with applicable laws governing the shipment of hazardous materials.

Note: Some contaminated equipment may not be suitable for airfreight.

PROCEDURE

1. Contact BOC Edwards and obtain a Return Authorisation Number for your equipment.
2. Complete the Return of BOC Edwards Equipment - Declaration (HS2).
3. If the equipment is contaminated, you must contact your transporter to ensure that you properly classify the hazard, mark, manifest and ship the equipment, in accordance with applicable laws governing the shipment of contaminated/hazardous materials. As the person offering the equipment for shipment, it is your responsibility to ensure compliance with applicable law. **Note: Equipment contaminated with some hazardous materials, such as semiconductor by-products, may not be suitable for airfreight - contact your transporter for advice.**
4. Remove all traces of hazardous gases: pass an inert gas through the equipment and any accessories that will be returned to BOC Edwards. Where possible, drain all fluids and lubricants from the equipment and its accessories.
5. Seal up all of the equipment's inlets and outlets (including those where accessories were attached) with blanking flanges or, for uncontaminated product, with heavy gauge tape.
6. Seal equipment in a thick polythene/polyethylene bag or sheet.
7. If the equipment is large, strap the equipment and its accessories to a wooden pallet. If the equipment is too small to be strapped to a pallet, pack it in a suitable strong box.
8. Fax or post a copy of the Declaration (HS2) to BOC Edwards. The Declaration must arrive before the equipment.
9. Give a copy of the Declaration (HS2) to the transporter. You must tell your transporter if the equipment is contaminated.
10. Seal the original Declaration in a suitable envelope: attach the envelope securely to the outside of the equipment package, in a clear weatherproof bag.

WRITE YOUR RETURN AUTHORISATION NUMBER CLEARLY ON THE OUTSIDE OF THE ENVELOPE OR ON THE OUTSIDE OF THE EQUIPMENT PACKAGE.

Return of BOC Edwards Equipment - Declaration

Return Authorisation Number: _____

You must:

- Know about all of the substances which have been used and produced in the equipment before you complete this Declaration
- Read the Return of BOC Edwards Equipment - Procedure (HS1) before you complete this Declaration
- Contact BOC Edwards to obtain a Return Authorisation Number and to obtain advice if you have any questions
- Send this form to BOC Edwards before you return your equipment

SECTION 1: EQUIPMENT

Equipment/System Name _____

Part Number _____

Serial Number _____

Has the equipment been used, tested or operated ?

YES Go to Section 2 NO Go to Section 4

IF APPLICABLE:

Tool Reference Number _____

Process _____

Failure Date _____

Serial Number of Replacement Equipment _____

SECTION 2: SUBSTANCES IN CONTACT WITH THE EQUIPMENT

Are any substances used or produced in the equipment:

- Radioactive, biological or infectious agents, mercury, poly chlorinated biphenyls (PCBs), dioxins or sodium azide? (if YES, see Note 1) YES NO
- Hazardous to human health and safety? YES NO

Note 1 : BOC Edwards will not accept delivery of any equipment that is contaminated with radioactive substances, biological/infectious agents, mercury, PCB's, dioxins or sodium azide, unless you:

- Decontaminate the equipment
- Provide proof of decontamination

YOU MUST CONTACT BOC EDWARDS FOR ADVICE BEFORE YOU RETURN SUCH EQUIPMENT

SECTION 3: LIST OF SUBSTANCES IN CONTACT WITH THE EQUIPMENT

Substance name	Chemical Symbol	Precautions required (for example, use protective gloves, etc.)	Action required after a spill, leak or exposure

SECTION 4: RETURN INFORMATION

Reason for return and symptoms of malfunction _____

- If you have a warranty claim:
- who did you buy the equipment from ? _____
 - give the supplier's invoice number _____

SECTION 5: DECLARATION

Print your name: _____ Print your job title: _____

Print your organisation: _____

Print your address: _____

Telephone number: _____ Date of equipment delivery: _____

I have made reasonable enquiry and I have supplied accurate information in this Declaration. I have not withheld any information, and I have followed the Return of BOC Edwards Equipment - Procedure (HS1).

Note: Please print out this form, sign it and return the signed form as hard copy.

Signed: _____ Date _____

This page intentionally blank.

UNITED KINGDOM

CORPORATE HEADQUARTERS

BOC EDWARDS

Manor Royal
Crawley
West Sussex
RH10 9LW
Tel +(44) 1293 528844
Fax +(44) 1293 533453

BOC EDWARDS

Wingates Industrial Estate
Great Bank Road
Westthoughton, Bolton
Lancashire
BL5 3SL
Tel +(44) 1942 652652
Fax +(44) 1942 652651

AMERICA (USA)

USA HEADQUARTERS

BOC EDWARDS

One Edwards Park
301 Ballardvale Street
Wilmington, MA 01887
Tel +(1) 978 658 5410
Toll free (USA only) 1 800 848 9800
Fax +(1) 978 658 7969

3901 Burton Drive
Santa Clara, CA 95054
Tel +(1) 408 496 1177
Fax +(1) 408 496 1188

1810 West Drake Drive
Suite 101
Tempe, AZ 85283
Tel +(1) 480 777 7007
Fax +(1) 480 777 2244

11701 Stonehollow Drive
Suite 100
Austin, TX 78758
Tel +(1) 512 491 6622
Fax +(1) 512 491 0629

3501 Island Avenue
Philadelphia, PA 19153
Tel +(1) 215 365 8653
Fax +(1) 978 753 6846

BELGIUM

BOC EDWARDS

Bergensesteenweg 709
B1600 Sint-Pieters-Leeuw
Brussels
Tel +(32) 2 363 0030
Fax +(32) 2 363 0064

BRAZIL

BOC DO BRASIL LTDA DIVISÃO EDWARDS ALTO VACO

Rua Bernado Wrona 222
02710 São Paulo-SP
Tel +(55) 11 3952 5000
Fax +(55) 11 3965 2766

CANADA

BOC EDWARDS

5975 Falbourne Street
Mississauga, Ontario L5R3W6
Canada
Tel +(1) 905 501 2558
Fax +(1) 905 501 1632

12055 Cote de Liesse
Dorval, Quebec H9P1B4
Canada
Tel +(1) 514 631 3501
Fax +(1) 514 631 3502

CHINA

BOC TRADING (SHANGHAI) CO. LTD.

23 Fu Te Road (N)
Wai Gao Qiao Free Trade Zone
Pudong
Shanghai, 200131
PRC China
Tel +(86 21) 5866 9618
Fax +(86 21) 5866 9993

FRANCE

BOC EDWARDS

125 Avenue Louis Roche
92238 Gennevilliers, Cedex
Paris
Tel +(33) 1 47 98 24 01
Fax +(33) 1 47 98 44 54

GERMANY

BOC EDWARDS

Ammerthalstraße 36
85551 Kirchheim
Munich
Tel +(49) 89 99 19 18 0
Fax +(49) 89 99 19 18 99

HONG KONG S.A.R.

BOC EDWARDS (ASIA)

12 Chun Yat Street
Tseung Kwan O Industrial Estate
Tseung Kwan O, Kowloon
Hong Kong S.A.R.
Tel +(852) 2372 2640
Fax +(852) 2796 9095

INDIA

BOC EDWARDS

DIVIN. OF BOC INDIA LIMITED
203 Surya Kiran Building
19 Kasturba Gandhi Marg
New Delhi - 110 001
India
Tel +(91) 11 851 0065
Fax +(91) 11 851 0245

ISRAEL

EDWARDS ISRAEL VACUUM LTD.

5 Habarzel Blvd
Gat 2000 Industrial Zone
Qiryat Gat 82000
Tel +(972) 8 681 0633
Fax +(972) 8 681 0640

ITALY

BOC EDWARDS

Via Carpaccio 35
20090 Trezzano sul Naviglio
Milan
Tel +(39) 02 48 4471
Fax +(39) 02 48 401638

JAPAN

HEADQUARTERS

BOC EDWARDS

Shuwa Shiba Park Building A-3F
2-4-1 Shibakoen Minato-ku
Tokyo, 105-0011
Tel +(81) (0) 3 5470 6530
Fax +(81) (0) 3 5470 6521

KOREA

HEADQUARTERS

SONGWON EDWARDS LTD.

5th FL. Daewoo Engineering Bldg.
Soonae-dong
Bundang-gu, Sungnam City
Kyungki-do, Korea
Tel +(82) 31 716 7070
Fax +(82) 31 738 1001-3

FACTORY & GV

SONGWON EDWARDS LTD.

625-7 Upsong-dong
Chunan City
Chungchong Nam-do
Korea
Tel +(82) 41 621 7070
Fax +(82) 41 621 7700

SINGAPORE

BOC EDWARDS (ASIA)

42 Loyang Drive
Loyang Industrial Estate
Singapore 508962
Tel +(65) 6546 8408
Fax +(65) 6546 8407

TAIWAN, R.O.C.

EDWARDS TECHNOLOGIES LIMITED

No. 434 Chung hua Road
Toufen Town, Miaoli County
Taiwan ROC
Tel +(886) 37 611422
Fax +(886) 37 611401

PLEASE CONTACT ANY OF THESE COMPANIES FOR DETAILS OF OTHER SALES AND SERVICE CENTRES IN YOUR AREA.

BOC Edwards is part of BOC Limited. BOC Edwards and the stripe symbol are trade marks of The BOC Group.
© BOC Edwards 2003

Produced by Technical Publicity Techpublicity@edwards.boc.com

<http://www.bocedwards.com>
info@bocedwards.com

The logo for BOC Edwards, featuring a stylized red and white striped graphic to the left of the text "BOC EDWARDS" in a bold, red, sans-serif font.