

# *Instruction Manual*

## Bellows, Flexible Pipelines and Braided Flexible Pipelines



This page has been intentionally left blank.

# Contents

Section	Page
1 INTRODUCTION .....	1
1.1 Scope and definitions .....	1
1.2 Description .....	1
1.2.1 Bellows .....	1
1.2.2 Flexible pipelines .....	1
1.2.3 Braided flexible pipelines .....	2
2 TECHNICAL DATA .....	3
2.1 Bellows .....	3
2.2 Flexible pipelines .....	4
2.3 Braided flexible pipelines .....	4
3 INSTALLATION .....	5
3.1 General .....	5
3.2 Bellows .....	5
3.3 Flexible pipelines .....	5
3.4 Braided flexible pipelines .....	5
4 STORAGE AND DISPOSAL .....	7
4.1 Storage .....	7
4.2 Disposal .....	7

For return of equipment, complete the HS Forms at the end of this manual.

# Illustrations

Figure	Page
1      A flexible pipeline formed into a tight bend .....	2

# Tables

Table	Page
1      Technical data: bellows .....	3
2      Technical data: flexible pipelines .....	4
3      Technical data: Braided flexible pipelines .....	4

# Associated publications

Publication title	Publication number
Vacuum pump and vacuum system safety	P300-20-000

# 1 INTRODUCTION

## 1.1 Scope and definitions

This manual provides installation instructions for the Edwards range of bellows, flexible pipelines and braided flexible pipelines. The Item Numbers for the products are listed in [Section 2](#). You must use the bellows, flexible pipelines and braided flexible pipelines as specified in this manual.

Read this manual before you install the bellows, flexible pipelines and braided flexible pipelines. Important safety information is highlighted as WARNING and CAUTION instructions; you must obey these instructions. The use of WARNINGS and CAUTIONS is defined below.



### WARNING

Warnings are given where failure to observe the instruction could result in injury or death to people.

### CAUTION

Cautions are given where failure to observe the instruction could result in damage to the equipment, associated equipment and process.

The units used throughout this manual conform to the SI international system of units of measurement.

## 1.2 Description

### 1.2.1 Bellows

*Note:* To install bellows safely, you must follow the guidelines given in [Section 3.2](#).

Bellows are short, thin-walled components with deep convolutions. They are used to reduce the transfer of vibration from a pump to a vacuum system.

### 1.2.2 Flexible pipelines

*Note:* To install flexible pipelines safely, you must follow the guidelines given in [Section 3.3](#).

Flexible pipelines have a thicker wall section and shallower convolutions than bellows. Flexible pipelines provide a convenient method of connecting vacuum system components and help to compensate for misalignment or small movements in rigid vacuum pipelines. Flexible pipelines can be formed into relatively sharp bends and will hold their position, as shown in [Figure 1](#); minimum bend radii do not apply.

Flexible pipelines are intended for installation in static systems. They are not suitable for repeated flexing. This could cause fatigue failure.

You must not use flexible pipelines on dry pump exhausts.

Figure 1 - A flexible pipeline formed into a tight bend

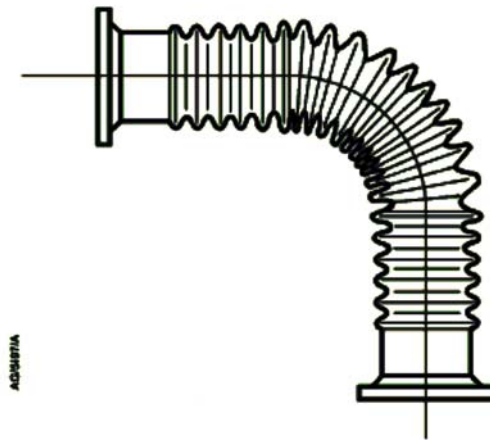

### 1.2.3 Braided flexible pipelines

*Note:* To install braided flexible pipelines safely, you must follow the guidelines given in Section 3.4.

Braided flexible pipelines have an outer protective layer of woven stainless steel braid. They are suitable for use as exhaust pipelines on Edwards dry pumps and other applications where there is significant gas pulsation or the possibility of high gas pressures.

Braided flexible pipelines are intended for installation in static systems. They are not suitable for repeated flexing. This could cause fatigue failure.

## 2 TECHNICAL DATA

### 2.1 Bellows

Table 1 - Technical data: bellows

Flange size	Length (mm)	Item Number	Maximum pressure *	
			Bar gauge	Pa
DN16CF	110	C100-01-340	0.2	1.2 x 10 <sup>5</sup>
DN40CF	160	C100-05-340	0.2	1.2 x 10 <sup>5</sup>
DN63CF	250	C100-07-540	1.0	2.0 x 10 <sup>5</sup>
DN100CF	250	C100-09-540	1.0	2.0 x 10 <sup>5</sup>
DN160CF	270	C100-11-540	1.0	2.0 x 10 <sup>5</sup>
DN200CF	300	C100-12-540	1.0	2.0 x 10 <sup>5</sup>
NW10	123	C105-11-670	0.2	1.2 x 10 <sup>5</sup>
NW16	123	C105-12-670	0.2	1.2 x 10 <sup>5</sup>
NW25	123	C105-14-670	0.2	1.2 x 10 <sup>5</sup>
NW40	123	C105-16-670	0.2	1.2 x 10 <sup>5</sup>
NW50	123	C105-17-670	0.2	1.2 x 10 <sup>5</sup>
ISO63	127	C100-07-670	1.0	2.0 x 10 <sup>5</sup>
ISO100	127	C100-09-670	1.0	2.0 x 10 <sup>5</sup>
ISO160	220	C100-11-670	1.0	2.0 x 10 <sup>5</sup>
ISO200	220	C100-12-670	1.0	2.0 x 10 <sup>5</sup>
ISO250	220	C100-13-670	1.0	2.0 x 10 <sup>5</sup>

\* With bellows in a straight line with both ends rigidly constrained

## 2.2 Flexible pipelines

Table 2 - Technical data: flexible pipelines

Flange size	Item Number				Maximum pressure		Minimum bend radius (mm)	
	250mm	500mm	750mm	1000mm	Bar gauge	Pa	Static	Dynamic
DN16CF	C100-01-330	C100-01-331	C100-01-332	C100-01-333	2.5	$3.5 \times 10^5$	30	130
DN40CF	C100-05-330	C100-05-331	C100-05-332	C100-05-333	1.2	$2.2 \times 10^5$	80	260
DN63CF	C100-07-530	C100-07-531	C100-07-532	C100-07-533	0.6	$1.6 \times 10^5$	140	360
DN100CF	C100-09-530	C100-09-531	C100-09-532	C100-09-533	0.5	$1.5 \times 10^5$	200	500
NW10	C105-11-285	C105-11-286	C105-11-300	C105-11-287	3.0	$4.0 \times 10^5$	30	100
NW16	C105-12-285	C105-12-286	C105-12-300	C105-12-287	2.5	$3.5 \times 10^5$	30	130
NW25	C105-14-285	C105-14-286	C105-14-300	C105-14-287	1.8	$2.8 \times 10^5$	50	210
NW40	C105-16-285	C105-16-286	C105-16-300	C105-16-287	1.2	$2.2 \times 10^5$	80	260
NW50	C105-17-285	C105-17-286	C105-17-300	C105-17-287	0.6	$1.6 \times 10^5$	100	300
ISO63	C100-07-285	C100-07-286	C100-07-288	C100-07-287	0.6	$1.6 \times 10^5$	140	360
ISO100	C100-09-285	C100-09-286	C100-09-288	C100-09-287	0.5	$1.5 \times 10^5$	200	500

## 2.3 Braided flexible pipelines

Table 3 - Technical data: Braided flexible pipelines

Flange size	Item Number				Maximum pressure		Minimum bend radius (mm)	
	250mm	500mm	750mm	1000mm	Bar gauge	Pa	Static	Dynamic
NW10	-	-	-	C105-11-288	-	10	$1.1 \times 10^6$	30
NW16	-	-	-	C105-12-288	-	10	$1.1 \times 10^6$	30
NW25	C105-14-294	C105-14-295	C105-14-296	C105-14-298	C105-14-297	10	$1.1 \times 10^6$	50
NW40	C105-16-294	C105-16-295	C105-16-296	C105-16-298	C105-16-297	10	$1.1 \times 10^6$	80
NW50	C105-17-294	C105-17-295	C105-17-296	C105-17-298	C105-17-297	10	$1.1 \times 10^6$	100



## 3 INSTALLATION



### *WARNING*

Use the correct flexible component for your application. If you do not, a pressure or fatigue failure could cause the component to leak and release dangerous process substances to atmosphere.

### 3.1 General

We recommend that you use only Edwards flexible pipelines with other Edwards vacuum products. Bellows, flexible pipelines and braided flexible pipelines are available in different lengths and flange sizes to suit your installation (see Section 2).

### 3.2 Bellows

Always install bellows in a straight line with both ends rigidly constrained. When installed correctly, the bellows can withstand a small positive internal pressure, as specified in Section 2. Do not use bellows on dry pump exhausts.

### 3.3 Flexible pipelines

When you install a flexible pipeline, use the shortest possible length and avoid unnecessary bends. Do not use flexible pipelines on dry pump exhausts.

### 3.4 Braided flexible pipelines

When you install a braided flexible pipeline, make sure that you observe the minimum bend radius data in Section 2. If you do not, the braid will become loose and will no longer support the internal flexible pipeline. This may result in fracture of the pipeline due to fatigue or overpressure failure.

This page has been intentionally left blank.

## 4 STORAGE AND DISPOSAL

### 4.1 Storage

Store the components in cool dry conditions until required for use. When required, install the components as described in Section 3.

### 4.2 Disposal



#### **WARNING**

Observe all appropriate safety precautions when you dispose of components which have been contaminated with process substances or pump fluids.

Dispose of the components in a safe manner in accordance with all local and national safety and environmental requirements.

This page has been intentionally left blank.