



# **Instructions Manual**

## **Compound Molecular Pump EBT70F**

**Be sure to read and understand all warnings in this manual before using the product.**

**Keep this manual readily available for reference.**

**EBARA Corporation**



## Safety



This section provides important safety information. Be sure to read this section thoroughly before using the compound molecular pump EBT70F, and follow all instructions.

Note that the scope of the cautions and warnings in this manual are limited to the range of our expectation. For your safety, follow all general rules (laws and regulations) in addition to the instructions provided herein.







EBARA reserves the right to make changes to the product specifications without notice, so as to maintain and improve the quality of the product. For this reason, the contents of this manual may not match exactly with the actual product.

## Symbols and Definitions









The following symbols and definitions are used for the warnings and cautions in this manual.

 Warning	Important information for preventing serious bodily injuries. Failure to follow instructions labeled with this symbol may result in death or serious injury.
 Caution	Important information for safe use of the pump. Failure to follow instructions labeled with this symbol may result in injury and/or property damage.
 Information	Information that may be useful when using the pump.



 Warning	<b>Instructions Manual</b>
	<p>This instructions manual (hereinafter, "this manual") provides safety notes, operation procedures, and maintenance and inspection procedures for the pump. All personnel must read and understand the contents of this manual, and handle the pump appropriately.</p>
 Warning	<b>Ambient temperature and humidity</b>
	<p>Do not use the pump in an area of high temperature or high humidity</p>
 Warning	<b>Water drip</b>
	<p>Do not use the pump where water drips.</p>
 Warning	<b>Installation</b>
	<p>Secure the pump to a mount or floor, and use the pump. Do not hang the pump above a walkway. If the pump is to be mounted to a equipment, read this manual thoroughly before designing the equipment, and design the equipment appropriately.</p>
 Warning	<b>Inspection</b>
	<p>Do not place your hands or foreign matters inside the pump.</p>
 Warning	<b>Process gas</b>
	<p>Do not use the pump to exhaust gallium, mercury, their compounds or corrosive gas. Doing so may result in pump failure.</p>
 Warning	<b>Overhaul</b>
	<p>Do not use the pump to exhaust toxic or reactive gas. If you could not help using the pump to exhaust toxic or reactive gas, purge the pump with inert gas before removing it from the equipment. Wear protective equipment to prevent exposure to the gas. When transporting the pump, seal the intake, purge port, vent port and exhaust.</p>



 Warning	<b>Disassembly and modification</b>
	Do not disassemble or modify the pump. It may result in serious accidents, causing death, serious injury, and/or property damage.
 Warning	<b>Air inrush</b>
	Do not make air inrush into the pump when operating the pump. It may result in injury and/or pump damage.
 Warning	<b>Exhaust piping</b>
	Do not exhaust process gas directly in a room. It may result in poisoning or choke. Make the exhaust piping to prevent poisoning and choke with process gas.
 Caution	<b>Dust, flammable gas and corrosive gas</b>
	Do not use the pump in an area exposed to dust, flammable gas or corrosive gas.
 Caution	<b>Magnetic field and electric field</b>
	Do not use the pump in a strong magnetic field or electric field.
 Caution	<b>Vibration</b>
	Do not use the pump in an area with a lot of vibration.
 Caution	<b>Cable connection</b>
	Do not disconnect the cable when operating the pump.
 Caution	<b>Start and stop</b>
	Do not start/stop the pump by turning input power on/off.
 Caution	<b>Backing pump</b>
	Connect a backing pump to the pump before using the pump.



<b>Allowable gas flow rate</b>	
 <b>Caution</b>	<b>Allowable gas flow rate of the pump is as follows. The allowable gas flow rate will vary depending on exhaust pressure, ambient temperature and so on.</b>
	<b>EBT70FRAB / EBT70FCAB</b>
	<b>Nitrogen : 37 Pa·L/s [20 sccm]</b>
	<b>Argon: 18 Pa·L/s [10 sccm]</b>
	<b>EBT70FRNB / EBT70FCNB</b>
<b>Nitrogen : 18 Pa·L/s [10 sccm]</b>	
<b>Argon: 9.2 Pa·L/s [5 sccm]</b>	
	<b>If you expect to exceed the allowable gas flow rate, consult EBARA prior to use.</b>



## **Warranty and Liability**

**EBARA guarantees the quality of its pumps, controllers, and their accessories as described in the included "Standard Warranty Certificate". Note, however, that handling the pump in manners not described in this manual will void all warranty. Use of the pumps and controllers under atypical conditions without prior consent from EBARA may also void the warranty.**



## Contents

	Page
<b>1. Characteristics</b> .....	<b>8</b>
<b>2. Unpacking and carrying</b> .....	<b>8</b>
2-1. Unpacking	
2-2. Carrying	
<b>3. Installation</b> .....	<b>10</b>
3-1. Dimensions	
3-2. Name of pump parts	
3-3. Name plates	
3-4. Conditions of usage	
3-5. Cooling	
3-6. Securing	
<b>4. Electrical wiring</b> .....	<b>18</b>
4-1. Required power capacity	
4-2. Cable connection	
<b>5. Vacuum piping</b> .....	<b>19</b>
5-1. Intake piping	
5-2. Backing pump selection	
5-3. Exhaust piping	
5-4. Purge port piping	
5-5. Vent port piping	
<b>6. Operation</b> .....	<b>22</b>
6-1. Precaution before operation	
6-2. Preparation before putting power	
6-3. Putting power	
6-4. Operation	
6-5. Procedure of start / stop	
6-6. Start / stop during operation	
<b>7. Protection</b> .....	<b>25</b>
<b>8. Baking</b> .....	<b>27</b>
<b>9. Maintenance</b> .....	<b>27</b>
9-1. Vibration	
9-2. Dust	



9-3. Reaction product	
9-4. Gas handling	
9-5. Exchange of bearing	
9-6. Air inrush	
9-7. Caution about operation at low temperature	
<b>10. Storage</b> -----	<b>29</b>
<b>11. Overhaul and service recommended</b> -----	<b>30</b>
<b>12. Scrapping</b> -----	<b>31</b>
<b>13. Specifications</b> -----	<b>31</b>
13-1. Specifications of pump part	
13-2. Specifications of controller part	





## 1. Characteristics

- 1) Compound molecular pump EBT70F is a controller-integrated type. This pump is an industrial equipment. It uses grease-lubricated ball bearings to support a rotor, which spins at high speeds to pump gas molecules from the inlet to the exhaust.
- 2) The integrated controller is a high frequency inverter. The controller starts up the pump in a short time with optimum control.
- 3) The controller realizes small size, light weight and high reliability by sensorless and brushless motor control.
- 4) The pump and controller is conformed to regulations as follows.

EMC directive

EN61000-6-4:2001

EN55011:1998 / A1:1999/A2:2002(Group1 Class A)

EN61000-4-2:1995+A1:1998+A2:2001

EN61000-4-3:2002+A1:2002

EN61000-4-5:1995+A1:2001

EN61000-4-6:1996+A1:2001

EN61000-4-8:1993+A1:2001

## 2. Unpacking and carrying

### 2-1. Unpacking

Check the following items before unpacking.

A: Unpacking

Table 1 lists the pump weight.

Table 1 Pump weight

Pump model	Weight
EBT70FRAB / EBT70FRNB	3.0 kg [7 lb]
EBT70FCAB / EBT70FCNB	5.0 kg [11 lb]

B: Damage to the contents

Should any of the package contents be damaged or defective, contact EBARA prior to use.



C: Accessories

The standard package includes following accessories. Should any item be missing, contact EBARA.

- |  |         |
|--|---------|
| (1) Power/Remote connector                       | 1 set   |
| (2) Instructions manual                          | 1 copy  |
| (3) Intake protective screen                     | 1 set   |
| (4) Temporary flange (cap) for Intake protection | 1 set   |
| (5) Protection cap for exhaust                   | 1 piece |

**2-2. Carrying**

When carrying the pump, or when mounting/dismounting the pump to/from the equipment, handle the pump with care.

 Caution	<b>Avoid applying a shock onto the pump.</b>
---	--

 Information	<b>We suggest that you keep the temporary flange (cap) and the protection cap stored for reuse when dismantling the pump. We suggest that you keep the packaging stored for reuse.</b>
---	--

3. Installation

3-1. Dimensions

	A	B	C	D	E	F	G
EBT70F	ISO-R63	95	12	50.5	144.5	115.5	115.5
	CF63	114	18	76	170	141	141

EBT70FRAB / EBT70FCAB

(Forced air cooling type)

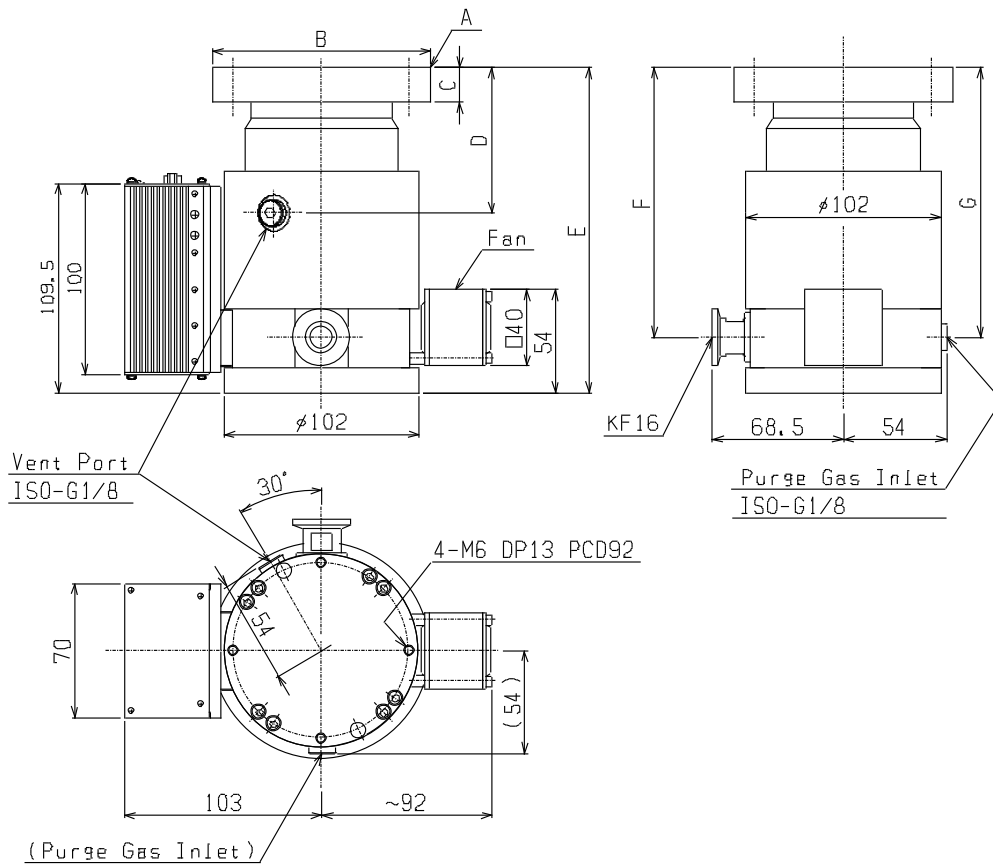

**EBT70FRNB / EBT70FCNB**  
**(Free convection air cooling type)**

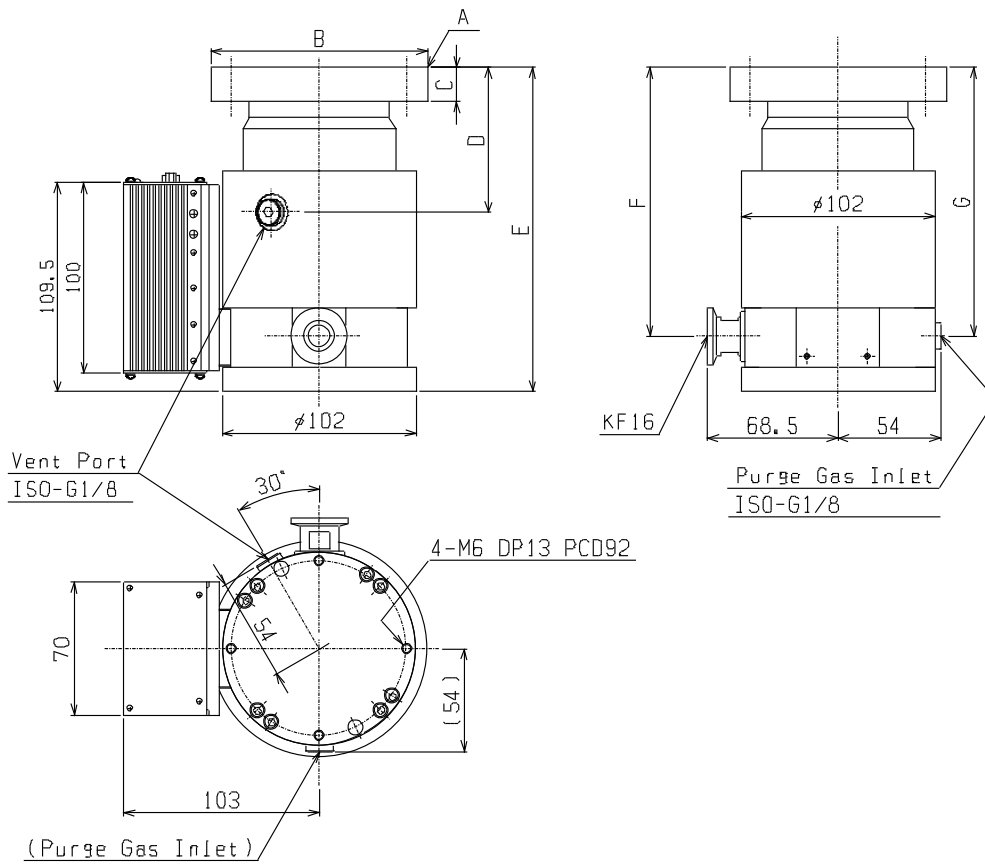

3-2. Name of pump parts

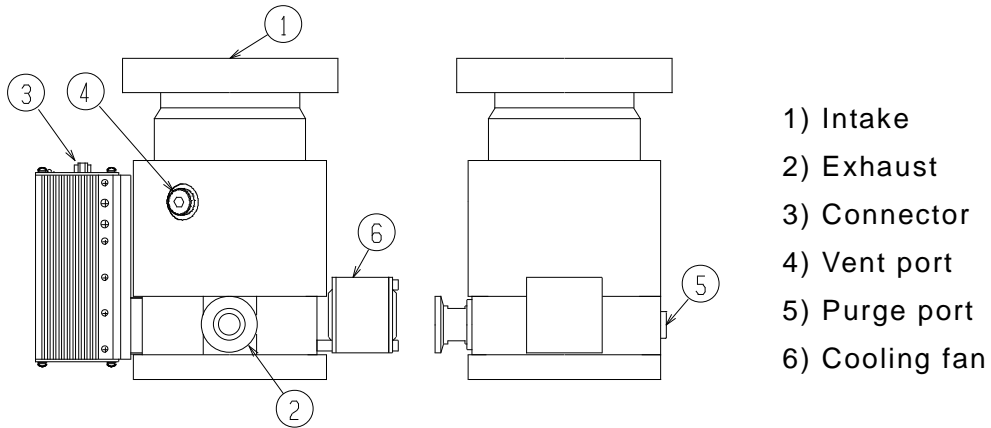

Figure 1 Name of pump parts

3-3. Name plates

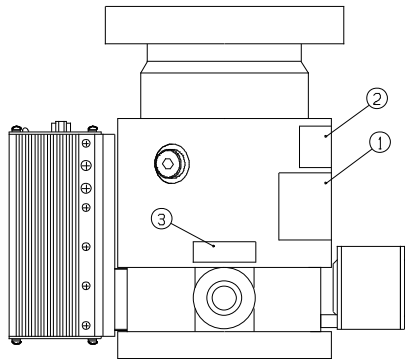
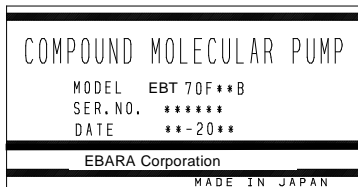

Figure 2 Name plates

1) Main name plate

Indicates the pump's model name, serial number and date of manufacture.



2) Warning label

Indicates pump weight.



3) Warning label

Connect to the backing pump.



**3-4. Conditions of usage**

1) Ambient temperature

 <b>Warning</b>	<b>The pump becomes hot during operation. Ambient temperature in operation must not exceed 38°C [100°F]. If the temperature exceeds, It may cause pump failure.</b>
--	---

2) Ambient humidity and water drip

Ambient relative humidity must not exceed 85 %. And do not use the pump where water drips. It may cause pump failure.

 <b>Warning</b>	<b>If you use the pump in an area with high humidity or water drip, it may cause pump failure.</b>
--	--

3) Dust

 <b>Caution</b>	<b>Do not use the pump in an area exposed to dust. It may cause pump failure.</b>
--	---

4) Toxic/explosive/flammable gas

 <b>Caution</b>	<b>Do not use the pump in an area with toxic gas such as acid, alkali, corrosive gas and so on. Also, do not use the pump in an area with explosive gas or flammable gas. It may cause pump failure.</b>
--	--



5) Magnetic field

Do not operate the pump within a magnetic field. The pump has a tolerance for magnetic fields of up to 2.5 mT (25 Gauss) in the direction perpendicular to the axis, and up to 15 mT (150 Gauss) in the direction of the axis. If the pump must be operated within a magnetic field that exceeds the tolerated value, use magnetic shielding. Also, consult EBARA.

 <b>Caution</b>	<b>If the pump is operated within a magnetic field, the rotor temperature will increase, and may cause rotor damage and pump failure.</b>
--	---

6) External shocks and vibrations

 <b>Caution</b>	<b>Do not apply shocks and vibrations to the pump during operation. It may cause pump failure.</b>
--	--

**3-5. Cooling**

Pump must be cooled during operation. Connect a power supply of DC24V to the cooling fan integrated. And use the pump within the allowable gas flow rate and ambient temperature.

Surface temperature of the pump must not exceed 50 °C [122 °F] during operation.

Table 2 lists specifications of cooling fan integrated in EBT70FRAB/EBT70FCAB.

When using EBT70FRNB/EBT70FCNB, prepare a fan equivalent to or larger than it.

Table 2 Specifications of cooling fan integrated

Flow rate	0.32 m <sup>3</sup> /min [11.3cfm]
Input Voltage (polarity)	DC24 V (red plus / black minus)
Rated current (Power)	0.095A (2.28 W)

 <b>Caution</b>	<b>Surface temperature of the pump must not exceed 50 °C [122 °F] during operation. It may cause pump failure.</b>
--	--



**3-6. Securing**

Before mounting the pump, check that the vacuum seal surface of the pump's intake and exhaust are clean and intact.

 <p>Warning</p>	<p><b>If the rotor becomes damaged while the pump is in operation, a large torque will be generated. The torque causes the whole pump to try to rotate. Secure the pump for safety.</b></p>
--	---

 <p>Warning</p>	<p><b>Do not hang the pump above a walkway. Use fixing bolts listed in table 4 to secure the pump. If you have difficulty in obtaining the bolts of table 4, consult EBARA before securing.</b></p>
--	---

 <p>Caution</p>	<p><b>Be careful not to contaminate and/or scratch the intake and exhaust. And do not touch inside the pump. The pump may not be able to get sufficient performance by leak and/or contamination.</b></p>
--	---

When designing the equipment, frame, mount or floor which the pump is to be fixed to, ensure that it can withstand the rotational torque applied by the pump, listed in table 3.

Table 3 Rotational torque by pump rotor breakage

Pump model	Torque
EBT70F	350 N·m





Use bolts those satisfy or exceed specifications in table 4, and tighten all the bolts evenly and securely.

Table 4 Fixing bolts

Location		Bolt (Quantity and size)	P.C.D.	Bolt material (property class)
Intake flange	ISO-R63	4 - clamps	---	SUS304 (grade 70 or higher) or SCM435 (grade 8.8 or higher)
	CF63	8 - M8	92.1	
Bottom		4 - M6	92	

Secure the pump to the equipment or the mount at the intake flange and/or at the bottom utilizing the threaded holes prepared for securing the pump. Figure 3 illustrates examples of securing.

When you secure the pump on the intake only with clamps, apply lubricant such as molybdenum disulfide to the thread and the washer face. If lubricant is not applied, clamping force will be insufficient.

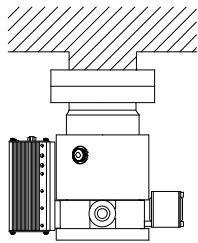

Example A

When the intake flange of the pump installs to the rigid equipment, secure the pump with the bolts listed in table 4 firmly.

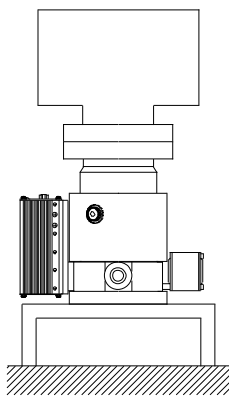

Example B

When the chamber installs to the intake flange of the pump, secure the pump to the pump stand with the bolts listed in table 4 and also secure the pump stand to the rigid floor or the frame firmly.

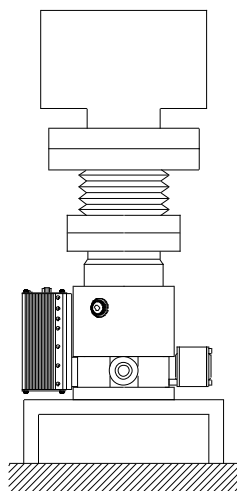

Example C

When the intake flange of the pump installs to soft system such as bellows, secure the pump to the pump stand with the bolts listed in table 4 and also secure the pump stand to the rigid floor or the frame firmly.

Figure 3 Examples of securing

**4. Electrical wiring**

**4-1. Required power capacity**

Required input voltage of the controller is DC24V, and maximum input current is 5.0A.

Use a direct current unit which is conformed with the specifications as follows.

- 1) It has double insulation or reinforced insulation between input side (AC100 V / 200 V) and output side (DC24 V).
- 2) Conformed with proper law, directive, regulation and so on, according to use and country.
- 3) Conducted noise is conformed with the directives as follows.

FCC Part15 Class B  
 EN5011 Group1 Class B  
 EN5502 Class B

**4-2. Cable connection**

Table 5 lists the model of connector.

Keep the procedures as follows, for cable connection to the controller.

Table 5 connector

Connector on controller	D-sub15 pins (male) DALC-J15PAF-10L9 Japan Aviation Electronics Industry, Limited
Connector on cable (Pump accessory)	D-sub15 pins (female) 17JE-13150-02(D8A) DDK, Limited

Figure 4 illustrates I/O communications of the connector.

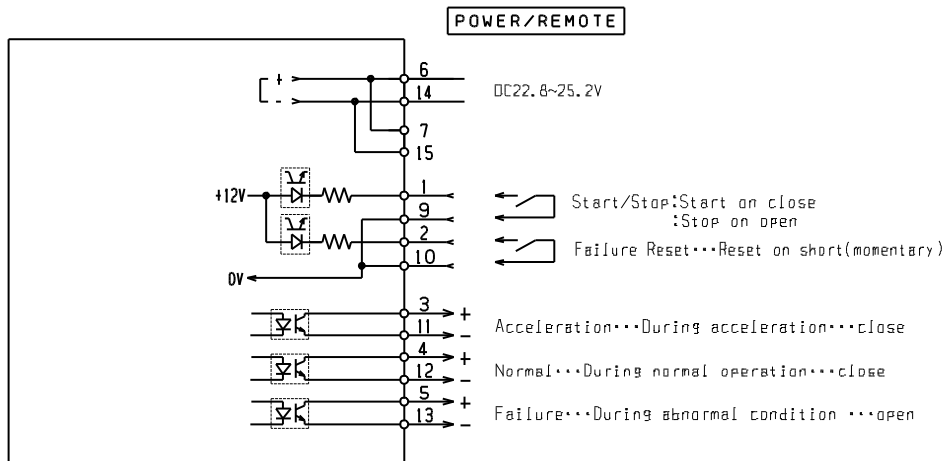



Figure 4 I/O communications of the connector



Table 6 lists recommended specifications of cable.

Table 6 Recommended specifications of cable

Cable (power)	0.5mm <sup>2</sup> [AWG20]
Cable (signal)	Shielded twisted-pair cable

 Caution	<b>Input power current runs with DC5.0A at maximum. Use a cable as power cable of which the size is applicable to DC5.0A.</b>
---	---

 Caution	<b>Fix the connector with screws not to disconnect from the controller.</b>
---	---

 Caution	<b>Make the impedance of input signal (Start/Stop, Reset) 1kiloohms or less at closed, and 100kiloohms or more at open. Make the contact capacity DC12V, 0.01A or more.</b>
---	---

 Caution	<b>Maximum capacity of output signal (Acc., Normal, Failure) is DC24V, 0.1A. When connecting, keep the polarity as illustrated in figure 4. If you reverse the connection, the signal does not work.</b>
---	--

## 5. Vacuum piping

### 5-1. Intake piping

- 1) Use piping made of materials with little outgassing, such as stainless steel and aluminum alloy.
- 2) When designing the piping, take conductance (ease of gas flow) into consideration.
- 3) Minimize the leakage from the piping and the equipment. To minimize outgassing, degrease and clean the internal surface of the piping.



**5-2. Backing pump selection**

The performance of the pump is affected by the capacity of the backing pump. When selecting the backing pump, refer to table 7, and select a pump that meets the capacity recommendation.

Table 7 Recommended backing pump capacity

Pump model	Recommended backing pump capacity
EBT70F	≥ 25 L/min

 <b>Caution</b>	<b>If the performance of the backing pump is low or becomes degraded, the pump may not perform at its best.</b>
--	---

 <b>Information</b>	<b>Use a trap or other measures to prevent the counterflow of oil mist into the pump. If the pump becomes contaminated by oil mist, it may not perform at its best.</b>
--	---

**5-3. Exhaust piping**

- 1) For the piping connected to the pump, use piping made of stainless steel or aluminum alloy, or a metal flexible tube.
- 2) The performance of the pump is affected by the conductance of the piping. To minimize the effect of conductance, the piping should be as short as possible, and as large in diameter as possible.
- 3) To prevent the pump from being affected by the vibration of the backing pump, use a metal flexible tube or a bellows.

Install the pump and the backing pump separately. Or, if installing them on the same mount, take anti-vibration measures.

 <b>Warning</b>	<b>Do not exhaust process gas directly in a room. It may result in poisoning or choke. Make the exhaust piping to prevent poisoning and choke with process gas.</b>
--	---

 <b>Caution</b>	<b>Install the pump and the backing pump, so that the pump is not affected by the vibration of the backing pump.</b>
--	--

### 5-4. Purge port piping

If the pump exhausts a gas with dust, purge the inside of the pump from purge port. Refer to figure 5. In general, nitrogen is used as the purge gas. Set the purge gas flow rate to 9.2 Pa-L/sec [5 sccm]. If you do not purge the pump, seal the purge port with a plug.

	<p><b>Caution</b></p> <p><b>If the flow rate of the purge gas is too large or too small, it may cause the performance of the pump to become degraded and/or cause pump failure.</b></p>
---	---

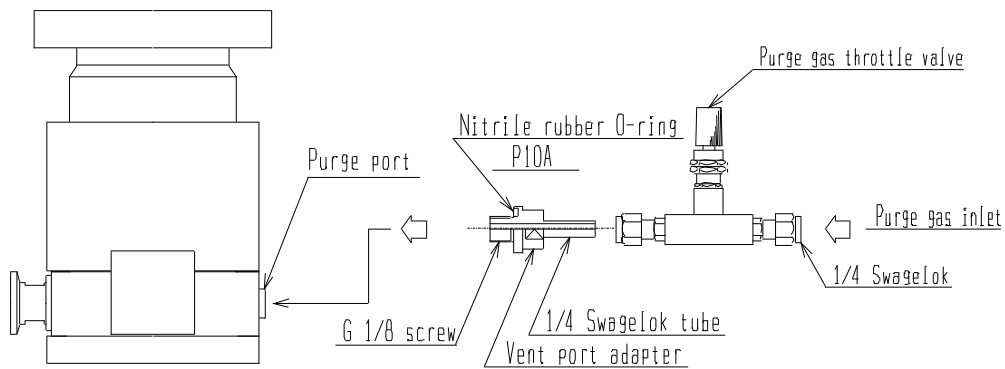

Figure 5 Example of purge port piping

### 5-5. Vent port piping

If you want to stop the pump quickly, you can shorten the shutdown time very much by venting a gas from vent port.

Be sure that the pump is stopping, and open the vent valve. Figure 6 illustrates an example of vent port piping. Set the vent-gas flow rate no more than 184 Pa-L/sec [100 sccm]. You can open the vent valve at the same time of sending Stop signal. Refer to section 6-5.

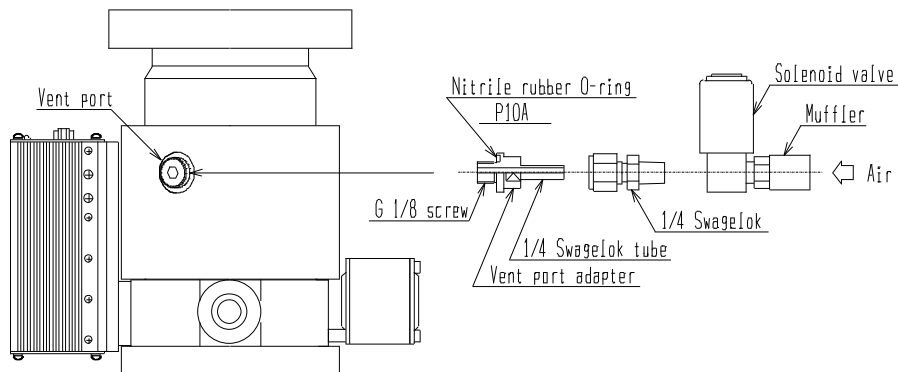



Figure 6 Example of vent port piping



## 6. Operation

### 6-1. Precaution before operation

- 1) Check the electrical wiring. Refer to section 4.
- 2) The pump must be cooled during operation. Refer to section 3-5.
- 3) Start the backing pump at first, and wait for the chamber pressure to drop to 260Pa [2.0Torr] before starting the pump. If you start the pump at high pressure of the chamber, the startup time will become longer, or it will fail to start up. Refer to table 8 in page 26.

 <b>Warning</b>	<b>Do not use the pump to exhaust gallium, mercury, their compounds or corrosive gas. It may result in pump failure.</b>
--	--

### 6-2. Preparation before putting power

Check the electrical wiring before putting the power on the controller.  
Use a power supply for input power, which has little ripple, noise, surge or voltage fluctuation.

 <b>Caution</b>	<b>Put the connector on the controller before turning input power on. The controller does not have any function of soft charge. If a connector with input power of 24V is put on the controller, input condenser sends inrush current to the connector, and it may cause melt and short-circuit of the connector. And do not disconnect the cable when operating the pump.</b>
--	--

### 6-3. Putting power

Apply the voltage (DC24V) on the pin No. 6 and 14 of the connector. The indicator on the top of controller turns green.



#### 6-4. Operation

Shorten the pin No. 1 and 9 of the connector, and the pump begins starting up. Open the pins, and the pump begins shutting down by free-running (without brake). Startup time is about 2.5 minutes, and shutdown time is about 25 minutes. Refer to Section13 about startup time and shutdown time.

Following signals are provided from the connector. Apply the signals what you want.

- 1) Acc. signal (Pin No. 3[plus], 11[minus])  
Closed when the rotational speed is 0-90 % of rated speed in starting up.
- 2) Normal signal (Pin No. 4[plus], 12[minus])  
Closed when the rotational speed is 90-100 % of rated speed.
- 3) Failure signal (Pin No. 5[plus], 13[minus])  
Open when the protection of the controller works.

 <b>Caution</b>	<b>Do not disconnect the connector when operating the pump.</b>
--	---

#### 6-5. Procedure of start / stop

As for procedure of start/stop, refer to following two examples.

 <b>Warning</b>	<b>Vent the inside of the pump to atmosphere when stopping the pump completely. Oil vapor may flow back to whole inside of the pump if the pump is kept in vacuum. Backflow like this case may cause degrading.</b> <b>Do not make the pressure inside the pump higher than 0.17MPa [0.7kgf/cm<sup>2</sup>G, 10.2psiG]. It may cause the pump damage.</b>
--	--





a. Example 1 (system with main valve and foreline valve)

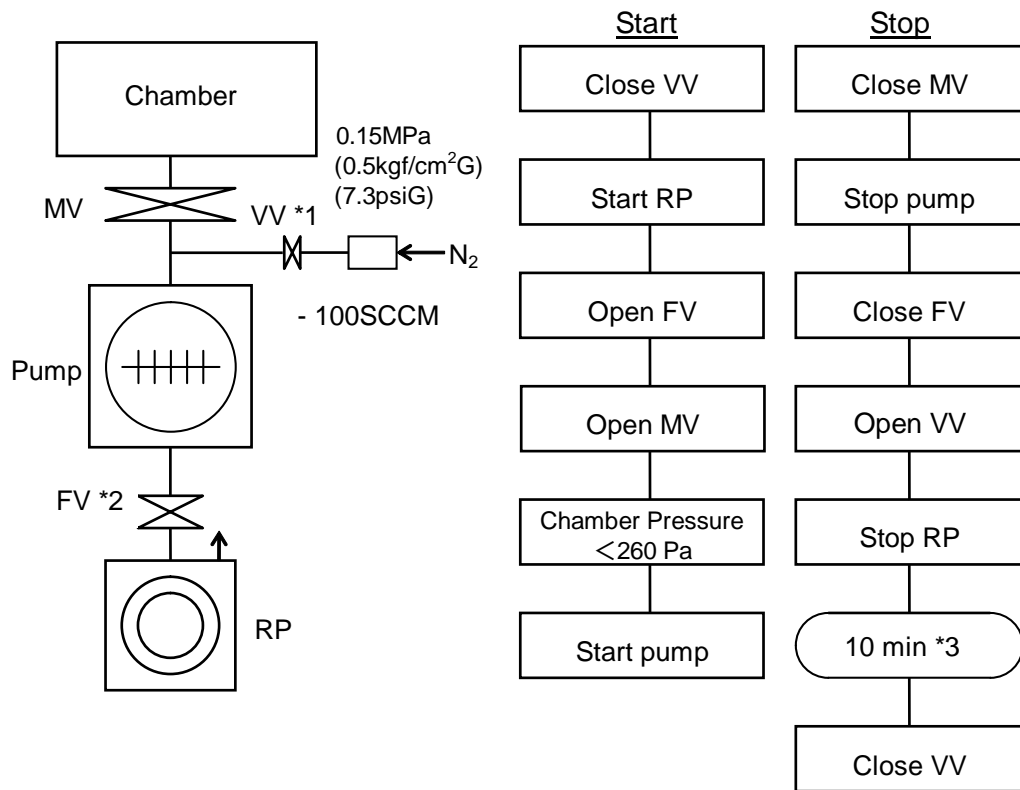

Pump: EBT70F  
 RP: Rotary pump  
 MV: Main valve  
 VV: Vent valve  
 FV: Foreline valve

- \*1 Attach a VV between the FV and the pump, according to the system.
- \*2 You can omit the FV if the RP equips a valve of shut-off type.
- \*3 Deceleration time of the rotor

Figure 7 Example 1 of start/stop procedure

**b. Example 2 (system without main valve or foreline valve)**

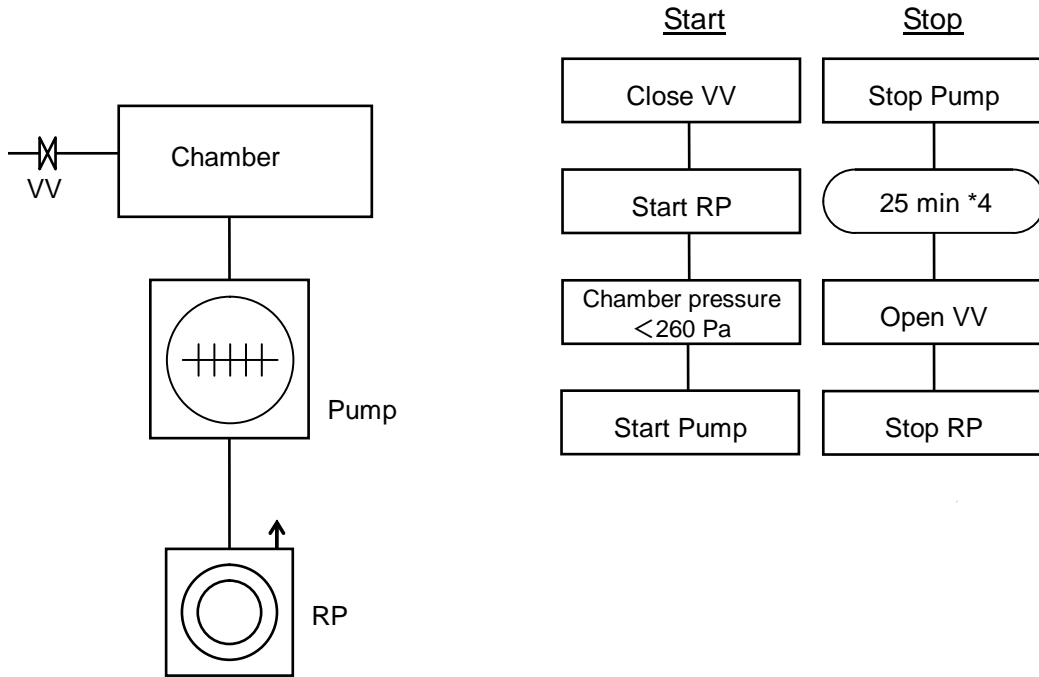

\*4 Deceleration time of the rotor

Figure 8 Example 2 of start/stop procedure

**6-6. Start / stop during operation**

The pumps can be decelerated while accelerated, or re-accelerated while decelerating. If the rotation speed is 50rps or slower when re-starting, the pump keeps decelerating for 65 seconds after receiving Start signal, and then begins to re-start.

**7. Protection**

If the controller or the pump has something wrong, the indicator on the top of controller turns red, and the pump begins shutting down by free-running (without brake).

In such a case, failure signal on pin No. 5 and 13 of the connector becomes open.

Table 8 and 9 list items of failure, causes and measures. Guess the cause, and remove it.



Table 8 Failure which can reset

Failure mode	Possible cause	Measure
Delay in acceleration Unable to reach the rated speed within 6 minutes from start.	<ol style="list-style-type: none"> <li>1) The backing pressure is too high.</li> <li>2) Leakage in the system.</li> <li>3) Too much of gas flow rate.</li> </ol>	<ol style="list-style-type: none"> <li>1) Keep the backing pressure 260Pa or lower.</li> <li>2) Check if the system has any leakage.</li> <li>3) Stop the gas flow during starting up.</li> </ol>
Motor step out Unable to control the motor because of too much load.	<ol style="list-style-type: none"> <li>1) Foreign matter is in the pump.</li> <li>2) The backing pressure is too high.</li> </ol>	<ol style="list-style-type: none"> <li>1) Send back the pump when it has foreign matter inside.</li> <li>2) Keep the backing pressure 260Pa or lower.</li> </ol>
Motor overheat The motor temperature in the pump is 105°C [221°F] or higher.	<ol style="list-style-type: none"> <li>1) Ambient temperature is too high.</li> <li>2) The backing pressure is too high.</li> <li>3) Too much of gas flow rate.</li> <li>4) Leakage in the system.</li> </ol>	<ol style="list-style-type: none"> <li>1) Keep the ambient temperature 38°C [100°F] or lower. Cool the pump and keep the surface temperature 50°C [122°F] or lower.</li> <li>2) Keep the backing pressure 1200Pa or lower.</li> <li>3) Keep the gas flow rate under the allowable rate.</li> <li>4) Check if the system has any leakage.</li> </ol>
Controller Overheat The temperature inside the controller is 80°C [176°F] or higher.	<ol style="list-style-type: none"> <li>1) Ambient temperature is too high.</li> </ol>	<ol style="list-style-type: none"> <li>1) Keep the ambient temperature 38°C [100°F] or lower.</li> </ol>
Input power voltage loss, drop off Input power voltage has kept 22.8V or lower for 20 msec.	<ol style="list-style-type: none"> <li>1) Input power voltage is lost or dropped off.</li> </ol>	<ol style="list-style-type: none"> <li>1) Check the input power voltage</li> </ol>

When you reset the controller, shorten the pin No. 2 and 10 of the connector. Keep shortening the pins for 5msec or longer. Remove the cause of failure before resetting. Note that the pump begins to start up as soon as you reset, if the Start/Stop signal is closed and you reset. Keep the Reset signal open usually.

You cannot reset the controller with the Reset signal if it has any failure listed in table 9. Put off the input power, wait for several minutes, and put in the input power again. If the failure keeps even after retrying, the controller has something wrong. Send the pump back to EBARA.

Table 9 Failure which cannot reset

Failure mode	Possible cause	Measure
Output over-current Motor current has exceeded a specified value.	Short-circuit on motor, etc.	Put off the input power, wait for several minutes, and put in the input power again.
System error Fatal error inside the controller	Breakdown of controller	If the pump keeps failure even after retrying, send the pump back to EBARA or our service centers.
Over speed Rotational speed has exceeded 105% of the rated speed.	Breakdown of controller	

### 8. Baking

Baking the chamber will improve the ultimate pressure. Do not allow the heat from the chamber to overheat the pump.

When baking the chamber, set the temperature of the intake flange to below 80°C [176°F] or lower.

### 9. Maintenance

#### 9-1. Vibration

If the level of pump vibration increases abnormally during normal operation, which you can feel by hand or measured full amplitude of the vibration is 1 μm or more with vibration meter, contact EBARA.

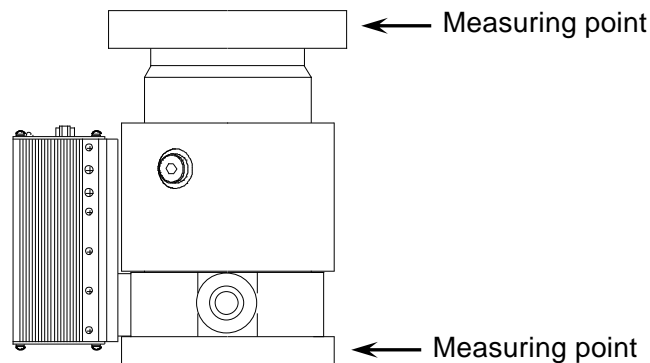

Figure 9 Measuring point of vibration on casing and housing



**9-2. Dust**

Depending on conditions, dust may accumulate inside the pump. Continued accumulation of dust may render the pump inoperable. Overhaul the pump periodically, according to the conditions.

**9-3. Reaction product**

Much accumulation of reaction products in the pump may render the pump inoperable, and more serious trouble. Overhaul the pump periodically if the pump has accumulation of reaction products.

 <b>Caution</b>	<b>The reaction products will corrode the internal components of the pump, making it impossible to overhaul the pump.</b>
--	---

**9-4. Gas handling**

When Handling gases, read the MSDS (Material Safety Data Sheet) provided by the gas supplier, and take appropriate protective measures to ensure safety.

**9-5. Exchange of bearing**

The lifetime of the bearing varies with conditions. Overhaul the pump periodically to exchange the bearings. Every 20,000 hours with non-reactive gas is recommended. Consult EBARA about exchange of the bearings if the pump needs to exhaust a gas with dust.

**9-6. Air inrush**

The pump can be restarted easily after an accidental air inrush. Contact EBARA if the pump has something wrong.

Take care and vent inside the pump of vacuum to atmosphere, not to make any part (O-ring, bolt, washer, etc.) around the pump suck in the pump.

**9-7. Caution about operation at low temperature**

It is possible that the pump gets failure of delay in acceleration, when operating the pump at low temperature. Because the viscosity of the lubricant rises by low temperature, it requires larger torque to accelerate, and the speed does not reach the rated speed within a specified time. In this case, re-start the pump after resetting the failure.



## 10. Storage

For long-term storage of the pump, seal the intake and the exhaust with blank flange and so on.

Purge the pump with inert gas such as nitrogen to remove reactive gas from inside of the pump.

When a reactive product is accumulated in the pump, overhaul the pump before storage.

Do not store the pump in the following area.

- 1) An area with high temperature or high humidity
- 2) An area with a strong magnetic field or electric field
- 3) An area exposed to reactive or corrosive gas
- 4) An area exposed to radiation
- 5) An area where water drips
- 6) An area with a lot of vibration
- 7) An area with a lot of dust

It is possible to get failure caused by bad lubrication when the pump is stored more than 6 months. If the pump has any problem, contact EBARA.

It is available for operation check of the pump at EBARA or our service centers. Or operate the pump every 6 months for lubrication of the bearing.



**11. Overhaul and service recommended**

The mean time of overhaul of the pump varies in applications and natures of gases pumping. Be sure to overhaul the pump before 20,000 hours operation, which is lifetime of bearing when the pump evacuates non-reactive gas only. The pump has to be overhauled, even with no problem when operation time reaches 20,000 hours. Consult EBARA about exchange of the bearings when the pump needs to exhaust reactive gas or dust.

Contact EBARA or a service agent contracted with EBARA when the pump needs overhaul or repair.

Be sure to disclose all the exhaust gases that are harmful and/or reactive, and even non-harmful and non-reactive gases before sending back to EBARA or the service agent. Otherwise, the pump cannot be overhauled or repaired.

Purge inside the pump with inert gas before sending back. Table 10 lists the volume inside the pump for reference. Cover the intake and the exhaust firmly to avoid leaking the reaction products from the pump.

Table 10 Volume inside the pump

Pump model	Volume
EBT70FRAB EBT70FRNB	0.2 L
EBT70FCAB EBT70FCNB	0.3 L

 <p>Warning</p>	<p><b>Do not use the pump to exhaust toxic or reactive gas.</b></p> <p><b>If you could not help using the pump to exhaust toxic or reactive gas, purge the pump with inert gas before removing it from the equipment. Wear protective equipment to prevent exposure to the gas.</b></p> <p><b>Be sure to disclose all the exhaust gases that are harmful and/or reactive, and even non-harmful and non-reactive gases before sending back to EBARA or the service agent. Otherwise, the pump cannot be overhauled or repaired.</b></p> <p><b>When transporting the pump, seal the intake and the exhaust.</b></p>
--	---



## 12. Scrapping

Scrap the pump as an industrial waste, in accordance with national and regional regulations.

## 13. Specifications

### 13-1. Specifications of pump part

Allowable gas flow rate	EBT70FRAB EBT70FCAB	N <sub>2</sub>	37 Pa·L/s [20 sccm]
		Ar	18 Pa·L/s [10 sccm]
	EBT70FRNB EBT70FCNB	N <sub>2</sub>	18 Pa·L/s [10 sccm]
		Ar	9.2 Pa·L/s [5 sccm]
Allowable backing pressure <sup>1)</sup>			1200 Pa [9Torr]
Backing pump recommended			≥ 25 L/min
Startup time			2 – 2.5 min (at 10Pa or lower of backing pressure)
Shutdown time			20 – 25 min (without venting)
Vibration (0-peak)			≤ 0.2 μm
Rated rotational speed			90000 min <sup>-1</sup>
Mount position <sup>2)</sup>			Free
Allowable surface temperature of pump			< 50 °C [122 °F] (Casing)
			< 50 °C [122 °F] (Housing)
Allowable ambient temperature			8 – 38 °C [46 – 100 °F]
Weight	EBT70FRAB EBT70FRNB	3.0 kg [7 lb]	
	EBT70FCAB EBT70FCNB	5.0 kg [11 lb]	
Refilling grease			No requirement
IP code			IP20 (service area, operating area)

1) Pressure which the pump can operate without gas load.

2) Secure the pump firmly to the equipment.





**13-2. Specifications of controller part**

Controller model		ETC75
Environment	Allowable temperature	0 – 45 °C
	Allowable humidity	5 – 85 %
Input	Voltage	DC 22.8 – 25.2 V
	Rated current	DC 5.0 A
	Input condenser	35 V, 2000 $\mu$ F
	Soft charge function	No function
Output	Phase	3
	Rate current	2.9 Arms
	Rated frequency	1500 Hz
Weight		Approx. 0.3 kg
IP code		IP30 (service area)

 <b>Caution</b>	<b>Do not put the controller to withstand voltage test. It may cause the pump damage.</b>
---	---



## Contacting EBARA

### U.S.A

EBARA TECHNOLOGIES, INC.  
51 Main Avenue  
Sacramento, CA 95838, U.S.A.  
Phone: 1-916-920-5451  
Fax: 1-916-925-6654

### Asia

Japan EBARA Corporation, Precision Machinery Group  
EBARA Corporation Fujisawa Plant  
4-2-1 Hon-Fujisawa, Fujisawa 251-8502, Japan  
Phone: 81-466-83- 9782  
Fax: 81-466-83- 8883

Korea EBARA Precision Machinery Korea, Inc.  
15 FL, Kangnam Bldg.  
321 Seocho-Dong, Seocho-Ku, Seoul, Korea  
Phone: 82-2-581-6901  
Fax: 82-2-581-4211

Taiwan EBARA Precision Machinery Taiwan, Inc.  
Room 1406A Chia Hsin Bldg., No. 96, Sec. 2  
Chung Shan N. RD., Taipei Taiwan  
Phone: 886-2-2560-1166  
Fax: 886-2-2560-1177

Singapore EBARA Engineering Singapore PTE. Ltd.  
No. 67 Tuas Ave 1  
Singapore, 638550  
Phone: 65-862-3536  
Fax: 65-861-0589

### Europe

United Kingdom EBARA Corporation Scotland Branch  
3 & 4 Adam Square-Brucefield Industrial Estate  
Livingston, G-8West Lothian, EH54 9DE U.K.  
Phone: 44-1509-460232  
Fax: 44-1506-460222

Germany EBARA Precision Machinery Europe GmbH  
Rodenbacher Chaussee 6,D-63457  
Hanau, Germany  
Phone: 49-6181-1876-0  
Fax: 49-6181-1876-40