

A PASSION FOR PERFECTION



## DUO 3

Dual-stage rotary vane pumps with a pumping speed up to 2.9 m<sup>3</sup>/h:



### DUO 3 M, 1-phase motor, 115/230 V, 50/60 Hz

- Dual-stage, high-performance rotary vane pump with a pumping speed of 2.5 m<sup>3</sup>/h at 50 Hz / 2.9 m<sup>3</sup>/h at 60 Hz
- With magnetic coupling
- With single-phase motor with C14 connector plug inside the terminal box
- Integrated gas ballast and safety valve
- Oil return device is included with the pump
- For all low and medium vacuum applications
- Special feature: various motor voltages for wide range of application fields

#### Characteristics

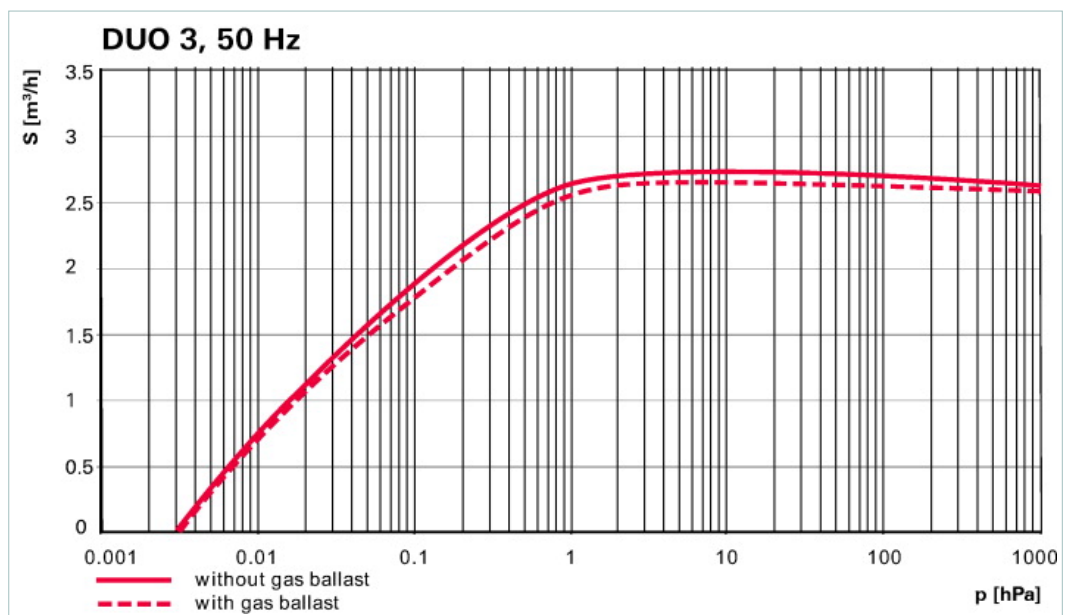

**Dimensions**

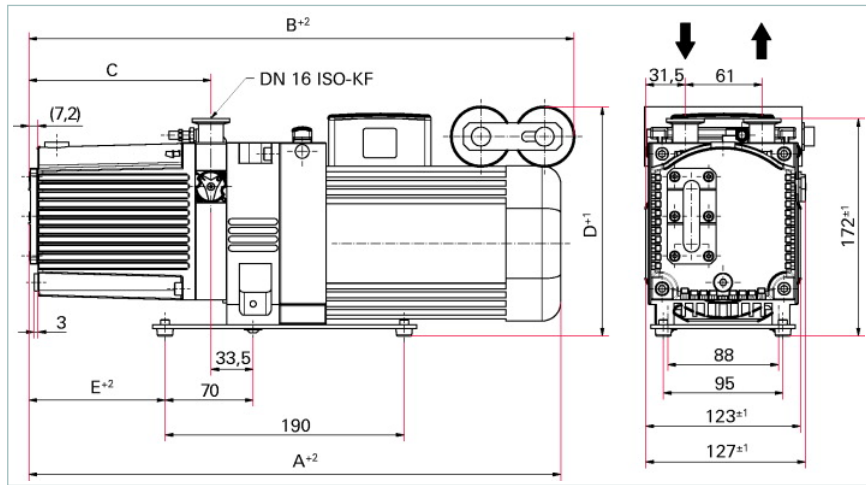

A	351 mm
B	386 mm
C	123 mm
D	176 mm
E	85.5 mm

Technical Data	DUO 3 M, 1-phase motor, 115/230 V, 50/60 Hz
Ambient temperature	12-40 °C   53.6-104 °F   285.15-313.15 °K
Cooling method, standard	Air
Emission sound pressure level without gas ballast at 50 Hz	<= 53 dB (A)
Exhaust pressure, max.	1,500 hPa   1,125 Torr   1,500 mbar
Exhaust pressure, min.	250 hPa   187.5 Torr   250 mbar
Flange (in)	DN 16 ISO-KF
Flange (out)	DN 16 ISO-KF
Leak rate safety valve	<= 1 · 10 <sup>-5</sup> Pa m <sup>3</sup> /s   <= 7.5 · 10 <sup>-5</sup> Torr l/s   <= 1 · 10 <sup>-4</sup> mbar l/s
Magnetic coupling	yes
Mains cable	No
Mains requirement: voltage (selectable)	230 V
Mains requirement: voltage 50 Hz	115 V
Mains requirement: voltage 60 Hz	115 V
Operating fluid	P3
Operating fluid filling	0.4 l
Protection category	IP 55
Pumping speed at 50 Hz	2.5 m <sup>3</sup> /h
Pumping speed at 60 Hz	2.9 m <sup>3</sup> /h
Rated power 50 Hz	0.15 kW
Rated power 60 Hz	0.18 kW
Rotation speed at 50 Hz	3000 min <sup>-1</sup>
Rotation speed at 60 Hz	3600 min <sup>-1</sup>
Switch	yes
Ultimate pressure with gas ballast	3 · 10 <sup>-3</sup> hPa   2.25 · 10 <sup>-3</sup> Torr   3 · 10 <sup>-3</sup> mbar
Ultimate pressure without gas ballast	3 · 10 <sup>-3</sup> hPa   2.25 · 10 <sup>-3</sup> Torr   3 · 10 <sup>-3</sup> mbar
Weight	12 kg   26.46 lb

Order number	
DUO 3	PKD57111

<b>Accessories</b>	
<b>Accessories DuoLine™</b>	
KAS 16, condensate separator for pumping speeds from 1.6 to 12 m <sup>3</sup> /h	<b>PKZ10003</b>
Oil return unit from ONF 16 M to DUO 1.6, 3	<b>PK006080-T</b>
Oil return unit from ONF 16 S to DUO 1.6 / DUO 3	<b>PK005986-T</b>
ONF 16 M, oil mist filter for pumping speeds of up to 12 m <sup>3</sup> /h	<b>PKZ40003</b>
ONF 16 S, oil mist filter for pumping speeds up to 12 m <sup>3</sup> /h	<b>PKZ40001</b>
Operations monitoring unit 1 for DUO 1.6/3/6/11 and DUO 5/10/20 M	<b>PK196157-T</b>
Operations monitoring unit 2 for DUO 1.6/3/6/11 and DUO 5/10/20 M	<b>PK196142-T</b>
Operations monitoring unit 3 for DUO 1.6/3/6/11 and DUO 5/10/20 M	<b>PK196141-T</b>
SAS 16, DN 16 ISO-KF, polyester filter	<b>PKZ60506</b>
ZFO 16, zeolite trap	<b>PKZ70003</b>
<b>Consumables</b>	
P3, mineral oil, 1 l	<b>PK001106-T</b>
P3, mineral oil, 0.5 l	<b>PK001136-T</b>

**Vacuum solutions  
from a single source**

Pfeiffer Vacuum stands for innovative and custom vacuum solutions worldwide, technological perfection, competent advice and reliable service.

**Complete range  
of products**

From a single component to complex systems:  
We are the only supplier of vacuum technology  
that provides a complete product portfolio.

**Competence in  
theory and practice**

Benefit from our know-how and our portfolio of training  
opportunities! We support you with your plant layout  
and provide first-class on-site service worldwide.

**Are you looking for a  
perfect vacuum solution?  
Please contact us:**

**Pfeiffer Vacuum GmbH**  
Headquarters · Germany  
T +49 6441 802-0  
info@pfeiffer-vacuum.de  
[www.pfeiffer-vacuum.com](http://www.pfeiffer-vacuum.com)