

Specifications

Air-Cooled

Instrumentation	Front display high pressure gauge Front display low pressure gauge Front display hour meter
Interlock Functions	Compressor over-temperature sensor Helium under-pressure sensor
Status Lights:	Front display POWER ON Front display RUN Front display OVERTEMPERATURE
Compressor	Scroll type for Helium service Sealed motor Oil lubricated and cooled
Operating Noise Level	67-70 db at 10 ft.
Power Switching	Integral magnetic contactor
Electrical Access	Top Panel
Coolant	Ambient Air
Weight	285 lbs.
Dimensions	26" H x 19" W x 24" D
Casters	Included



Services

Helium gas charge/vent valve with ½" Aeroquip fitting
Oil charge/drain valve with ¼" Aeroquip
Module interconnections with VCO O-ring face-seal fittings
Removable panels (sides, top, front)
Top electrical access panel

Electrical Power Requirement

5.5 kW, 208/240 V, 3 phase, 50/60 Hz, 17 amps
5.5 kW, 440/480 V, 3 phase, 50/60 Hz, 9 amps

Heat Exchanger

Separate air-cooled heat exchanger for helium and oil

Remote Operation

208V1 phase standard
110V1 phase optional
24V DC optional

Static Helium Pressure	Ambient Temperature Operating Range	Ambient Storage Temperature
210 ± 5 psig at 70°F (21°C)	40°F to 95°F (4°C to 35°C)	Above 40°F (4.44°C)

Main power cable	10 ft. (3m) pigtail
Remote start/stop connector	8 pin twist lock
Expander power connector	4 pin twist lock
Helium out	½" Aeroquip self-sealing fitting
Helium in	½" Aeroquip self-sealing fitting

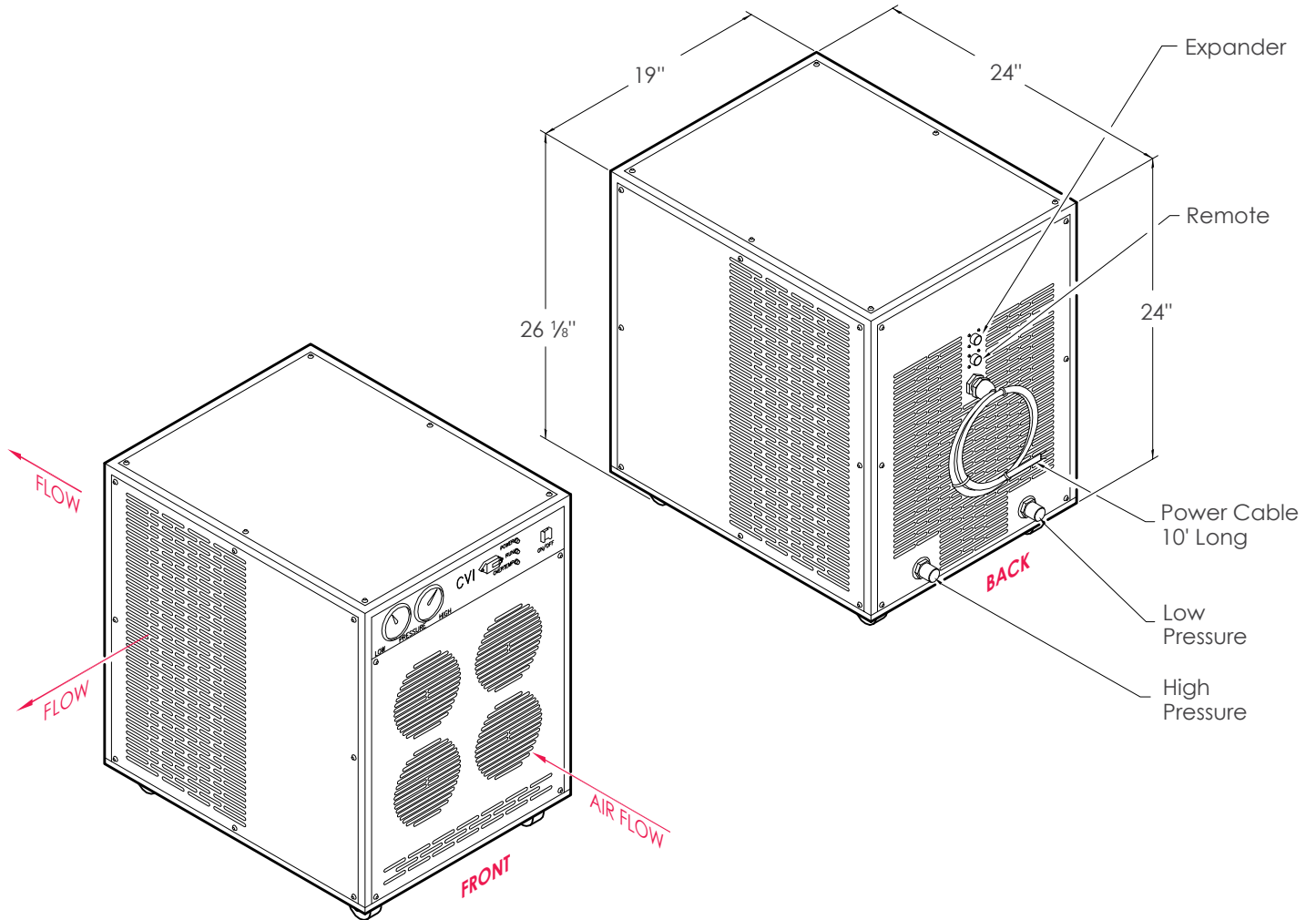

CBST 6.0 Air-Cooled Scroll Compressor