

POCHETTE DE JOINTS (A) – LOT DE MAINTENANCE (A) + (B)
 MINOR MAINTENANCE (A) – MAJOR MAINTENANCE (A) + (B)
 ERSATZDICHTUNGEN (A) – WARTUNGSMATERIAL (A) + (B)

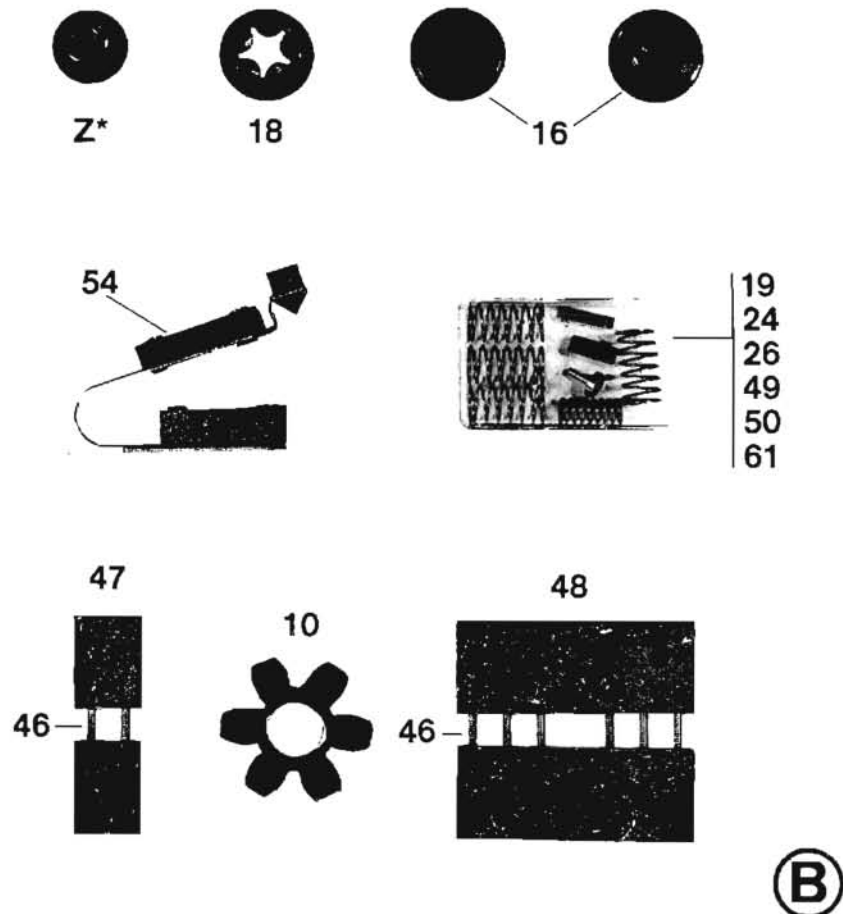
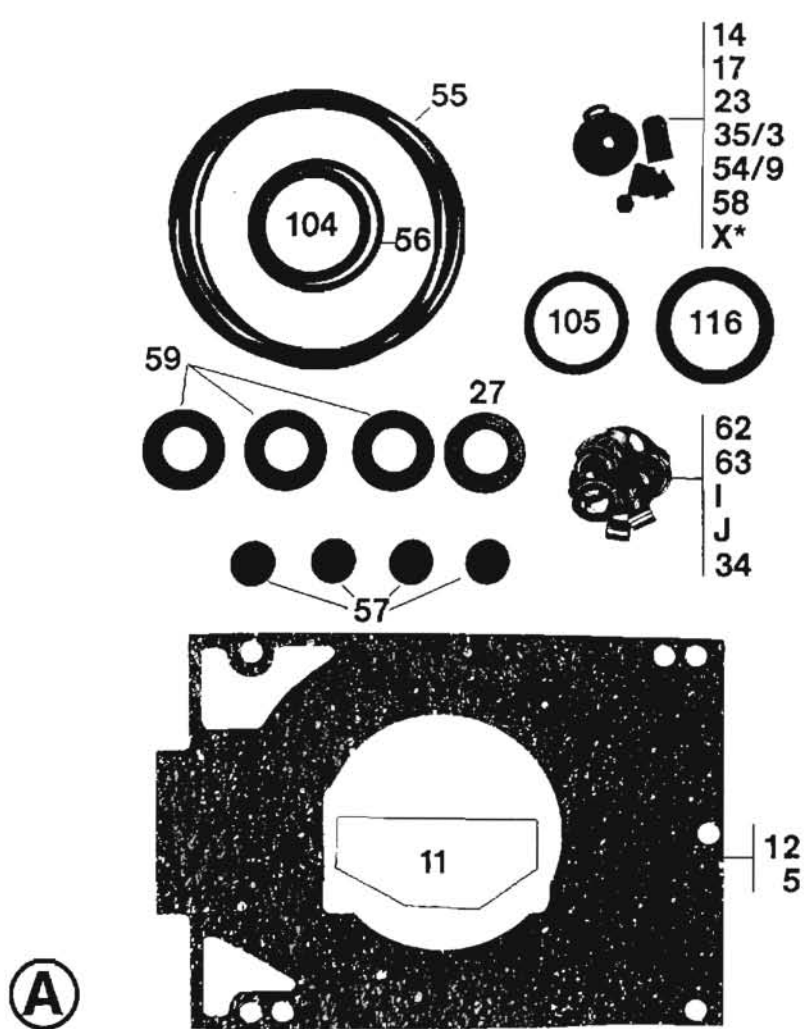

* Pompes ayant un numéro de série < 50000. Pumps with serial number before 50000. Pumpen mit Seriennummer vor 50000.

(Z) Bouchon G 1/4 / Plug G 1/4 / Blindstopf / (X) Clapet / Valve plate / Ventilteller

PIECES DE RECHANGE POUR :
ERSATZTEILLISTE FÜR :
SPARE PARTS LIST FOR : 1004 A - 2004 A - 2008 A - 1012 A - 2012 A - 2020 A

REP.	DESIGNATION	BENENNUNG	SPECIFICATION	TYPES						REF. Bestell. Nr P/N :	Poch. Joints Dichtungs. Minor maint.	Lot maint. Ersatzteils. Major maint.
				2020 A	2012 A	1012 A	2008 A	2004 A	1004 A			
1	Bâti	Pumpenträger	Coupling box	1	1	1	1	1	1	052545		
2	Cuve 20 m ³	Ölbehälter 20 m ³	Oil casing 20 m ³	1						052940		
2	Cuve 12 m ³	Ölbehälter 12 m ³	Oil casing 12 m ³	1	1	1				052546		
2	Cuve 4 m ³	Ölbehälter 4 m ³	Oil casing 4 m ³						1	052544		
3	Socle	Fuss	Base	1	1	1	1	1	1	052521		
4	Flasque moteur	Motorflansch	Handle plate	1	1	1	1	1	1	052547		
5	Joint de cuve	Öldichtung	Oil casing gasket	1	1	1	1	1	1	052755	x	
6	Amortisseur	Schwingmetall	Shock-absorber	4	4	4	4	4	4	052549		
3+6	Socle équipé	Gestattet Fuss	Equiped base	1	1	1	1	1	1	052422		
7	Goujon (long)	Gewindestift (long)	Connection pin (long)	2	2	2	2	2	2	052550		
8	Goujon (court)	Gewindestift (kurz)	Connection pin (short)	2	2	2	2	2	2	052551		
9	1/2 Manchon	Küplungshälfte	Fan coupling	1	1	1	1	1	1	052552		
10	Intercalaire	Küplungstern	Plastic coupling	1	1	1	1	1	1	052553		x
11	Feutre	Filz	Felt	1	1	1	1	1	1	052990	x	
12	Défecteur	Umlenkblech	Fan plate	1	1	1	1	1	1	052555	x	
13	Axe de soupape	Ventilstift	Valve pin	1	1	1	1	1	1	052556		
14	Soupape (refoulement)	Auspuffventil	Exhaust valve	1	1	1	1	1	1	052557	x	
15	Goujon	Stift	Pin	3						052942		
15	Goujon	Stift	Pin		3					052558		
15	Goujon	Stift	Pin				3		3	052584		
15	Goujon	Stift	Pin				3		3	052583		
15	Goujon	Stift	Pin					3	3	052585		
16	Bouchon mâle G 3/8"	Blindstopfen G 3/8"	Plug G 3/8"	2	2	2	2	2	2	082604		x
17	Joint c 2 - d 16	Dichtung c 2 - d 16	O-ring c 2 - d 16	2	2	2	2	2	2	084149	x	
18	Indicateur niveau G 1/2"	Ölschauglas	Oil level sight glass	1	1	1	1	1	1	083546		x
19	Clavette	Nutenstein	Shaft key	1	1	1	1	1	1	083649		x
20	Bouton de manœuvre	Gasballast Knopf	Gas ballast knob	1	1	1	1	1	1	052559		
21	Vis épaulée	Schraube	Screw	1	1	1	1	1	1	052560		
22	Piston lest d'air	Ventilkolben	Gas ballast piston	1	1	1	1	1	1	052561		
23	Clapet lest d'air	Gasballast Ventil	Gas ballast valve	1	1	1	1	1	1	052562	x	
24	Ressort du piston	Feder	Piston spring	1	1	1	1	1	1	052563		x
25	Bille 11/64", Ø 4,366 DIN 5401	Kugel 11/64", Ø 4,366 Din 5401	Bearing 11/64", Ø 4,366 Din 5401	1	1	1	1	1	1	082522		
26	Ressort de bille	Feder	Spring bearing	1	1	1	1	1	1	052564		x
27	Joint à lèvres (viton)	Lippendichtung (viton)	Shaft seal (viton)	1	1	1	1	1	1	082063	x	
28												
29	Filtre d'aspiration	Ansaugfilter	Inlet filter	1	1	1	1	1	1	052565		
30	Bride étrier	Spannstück	Clamping strap	1	1	1	1	1	1	052566		
30												
32	Moulinet	Flügelnocke	Impeller	1	1		1	1		052721		x
32	Moulinet	Flügelnocke	Impeller			1			1	052706		x
33												
34	Bague d'arrêt	Sprengring	Stopnut	1	1	1	1	1	1	071161	x	x
35	Rotor équipé HP	Hochdruck Rotor	High pressure rotor	1						052943		
35	Rotor équipé HP	Hochdruck Rotor	High pressure rotor		1		1	1		052712		
35/3	Aiguille Ø 1,5 x 9,8	Stütze	Pin	1	1		1	1		071050	x	
36	Siège de clapet	Ventilsitz	Pin supporting jet	1	1	1	1	1	1	052718		
37	Bride	Lasche für Ventilsitz	Jet support flange	1	1	1	1	1	1	052569		
39	Flasque arrière	HintererFlansche	Rear plate	1						052946		
39	Flasque arrière	HintererFlansche	Rear plate		1	1	1	1	1	052686		
40	Stator HP	HochdruckStator	High pressure stator	1						052948		
40	Stator HP	HochdruckStator	High pressure stator		1		1	1		052711		
41	Flasque médian	ZwischenFlansche	Central plate	1						052950		
41	Flasque médian	ZwischenFlansche	Central plate		1		1			052573		
42	Stator BP	NiederdruckStator	Low pressure stator	1						052952		
42	Stator BP	NiederdruckStator	Low pressure stator		1					052574		
42	Stator BP	NiederdruckStator	Low pressure stator				1			052582		
42	Stator BP	NiederdruckStator	Low pressure stator					1		052572		
43	Flasque avant	VordererFlansche	Front plate	1						052954		
43	Flasque avant	VordererFlansche	Front plate		1	1	1	1	1	052575		
44	Rotor BP	NiederdruckRotor	Low pressure rotor	1						052956		
44	Rotor BP	NiederdruckRotor	Low pressure rotor		1					052509		
44	Rotor BP	NiederdruckRotor	Low pressure rotor				1			052512		
44	Rotor BP	NiederdruckRotor	Low pressure rotor					1		052513		
45	Rouleau Ø 6 x 20	Zentrierstift Ø 6 x 20	Centering ring Ø 6 x 20	2	2	2	2	2	2	071059		
46	Ressort (palette)	Schieberfeder	Vane spring	8	8	7	6	4	2	053040		x
47	Palette HP	HochdruckSchieber	High pressure vane	2						052958		x
47	Palette HP	HochdruckSchieber	High pressure vane		2		2	4	2	083946		x
48	Palette BP	NiederdruckSchieber	Low pressure vane	2						052959		x
48	Palette BP	NiederdruckSchieber	Low pressure vane		2					083945		x
48	Palette BP	NiederdruckSchieber	Low pressure vane				2			053106		x

**PIECES DE RECHANGE POUR :
ERSATZTEILLISTE FÜR :
SPARE PARTS LIST FOR : 1004 A - 2004 A - 2008 A - 1012 A - 2012 A - 2020 A**

REP.	DESIGNATION	BENENNUNG	SPECIFICATION	TYPES						REF. Bestell. Nr P/N :	Poch. Joints Dichtungs. Minor maint.	Lot maint. Ersatzteils. Major maint.
				2020 A	2012 A	1012 A	2008 A	2004 A	1004 A			
49	Gicleur (médián)	Zentral Düse	Central jet	1	1	1	1	1	1	053474		x
50	Gicleur	Düse	Oil jet		1		1	1		052717		x
50	Gicleur	Düse	Oil jet			1				052728		x
50	Gicleur	Düse	Oil jet	1					1	052722		x
51												
52	Rotor/stator	Rotor/Stator	Rotor/stator			1				052671		
52	Rotor/stator	Rotor/Stator	Rotor/stator						1	052670		
53												
54	Levier équipé	Hebel	Equiped lever	1	1	1	1	1	1	052750		x
54/9	Clapet	Ventilteller	Valve plate	1	1	1	1	1	1	054340	x	
55	Joint c 2 - d 82 (viton)	Dichtung c 2 - d 82 (viton)	O-ring c 2 - d 82 (viton)	5	5	3	5	5	3	079030	x	
56	Joint c 2,5 - d 98	Dichtung c 2,5 - d 98	O-ring c 2,5 - d 98	1	1	1	1	1	1	083633	x	
57	Soupape	Auslassventil	Valve	4	4	3	3	2	1	052655	x	
58	Joint c 1,9 - d 5,7	Dichtung c 1,9 - d 5,7	O-ring c 1,9 - d 5,7	1	1	1	1	1	1	082105	x	
59	Joint à lèvres	Lippendichtung	Shaft seal	3	3	2	3	3	2	083645	x	
60	Capot de soupapes	Ventilgehäusedeckel	Valves cover	1						052963		
60	Capot de soupapes	Ventilgehäusedeckel	Valves cover		1	1				052580		
60	Capot de soupapes	Ventilgehäusedeckel	Valves cover				1			052538		
60	Capot de soupapes	Ventilgehäusedeckel	Valves cover					1		052539		
61	Ressort de soupapes	Ventilfeder	Valve spring	4	4	3	3	2	1	052541		x
62	Rouleau Ø 6	Zentrierstift Ø 6	Centering pin Ø 6	10	6	2	6	6	2	071040	x	
63	Frein d'axe	Sprengring	Clips	2	2	2	2	2	2	083653	x	
65	Cloison	Zwischenwand	Fan plate	1	1	1	1	1	1	052630		
66	Rouleau Ø 6	Zentrierstift Ø 6	Centering pin Ø 6	2	2	2	2	2	2	071041		
A	Vis M 8 x 20	Schraube M 8 x 20	Screw M 8 x 20	2	2	2	2	2	2	075514		
B	Vis M 8 x 16	Schraube M 8 x 16	Screw M 8 x 16	1	1	1	1	1	1	082734		
C												
D	Vis M 6 x 16	Schraube M 6 x 16	Screw M 6 x 16	2	2	2	2	2	2	075509		
E	Vis M 6 x 10	Schraube M 6 x 10	Screw M 6 x 10	3	3	3	3	3	3	075508		
F	Vis CM 6 x 8 bout plat	Schraube M 6 x 8 Fladkopf	Screw m 6 x 8 flat end	1	1	1	1	1	1	075048		
G	Ecrou HM 8	Mutter HM 8	Screw nut HM 8	3	3	3	3	3	3	071214		
H	Ecrou HM 6	Mutter HM 6	Screw nut HM 6	4	4	4	4	4	4	071211		
I	Rondelle Ø 8	Unterlagscheibe Ø 8	Washer Ø 8	6	6	6	6	6	6	073455	x	
J	Rondelle Ø 6	Unterlagscheibe Ø 6	Washer Ø 6	9	9	9	9	9	9	073454	x	
K	Rondelle ZU 4	Unterlagscheibe ZU 4	Washer ZU 4	3	3	3	3	3	3	073340		
VERSION EUROPEENNE - EUROPEAN VERSION - EUROPÄISCHE AUSFÜHRUNG												
102	Embout d'aspiration NW 25	Ansaugstutzen NW 25	Inlet port NW 25	1	1	1	1	1	1	052594		
103	Embout de refoulement NW 25	Auspuffstutzen NW 25	Exhaust port NW 25	1	1	1	1	1	1	052754		
104	Joint c 3,6 - d 29,3	Dichtung c 3,6 - d 29,3	O-ring c 3,6 - d 29,3	1	1	1	1	1	1	082122	x	
105	Joint c 3,6 - d 26,2	Dichtung c 3,6 - d 26,2	O-ring c 3,6 - d 26,2	1	1	1	1	1	1	082120	x	
108	Moteur mono. 220 V-50 Hz-1500 tr/mn-375 W	Wechselstrommotor 220 V-50 Hz-1500 tr/mn-375 W	Single phase motor 220 V-50 Hz-1500 rpm-375 W			1	1	1	1	052607		
108	Moteur mono. 230 V-50/60 Hz-1500/1800 tr/mn-	Wechselstrommotor 230 V-50/60 Hz-1500/1800 tr/mn-	Single phase motor 230 V-50/60 Hz-1500/1800 rpm-	1						052667		
108	Moteur tri. 220/380 V - 50 Hz - 1500 tr/mn - 375 W	Drehstrommotor 220/380 V - 50 Hz - 1500 tr/mn - 375 W	Three phase motor 220/380 V - 50 Hz - 1500 rpm - 375 W		1	1	1	1	1	052602		
108	Moteur tri. 220/380 V - 50 Hz - 1500 tr/mn - 550 W	Drehstrommotor 220/380 V - 50 Hz - 1500 tr/mn - 550 W	Three phase motor 220/380 V - 50 Hz - 1500 rpm - 550 W	1						052600		
108	Moteur mono. 240 V-50 Hz-1500 tr/mn-375 W	Wechselstrommotor 240 V-50 Hz-1500 tr/mn-375 W	Single phase motor 240 V-50 Hz-1500 rpm-375 W		1	1	1	1	1	052697		
109	Vis CHc - M 8 x 16	Schraube CHc - M 8 x 16	Screw CHc - M 8 x 16	4	4	4	4	4	4	082734		
109*	Vis CHc - 5/16"	Schraube CHc - 5/16"	Screw CHc - 5/16"	4	4	4	4	4	4	075037		
110	Rondelle Ø 8	Unterlagscheibe Ø 8	Washer diam. 8	4	4	4	4	4	4	073455		
111	1/2 Manchon moteur	Küplungshäfte	Motor coupling	1	1	1	1	1	1	052554		
115*	Vis CHc - 3/8"	Schraube CHc - 3/8"	Screw CHc - 3/8"	4	4	4	4	4	4	075038		
116	Joint torique C 5-D 28	Dichtung C 5-D 28	O-ring C 5-D 28	1	1	1	1	1	1	079238	x	
117	Protecteur NW 20-NW 25	Schutzkappe	Protector	2	2	2	2	2	2	068000		
124*	Rondelle ond. Ø 10	Unterlagscheibe diam. 10	Washer diam. 10	4	4	4	4	4	4	073456		
129	Vis Hc - M 6 x 10	Schraube Hc - M 6 x 10	Screw Hc - M 6 x 10	1	1	1	1	1	1	075034		
* Pour les pompes équipées de moteur 60 Hz				* Für die Pumpen mit 60 Hz Motor				* For pumps with 60 Hz motor				

**PIECES DE RECHANGE POUR :
ERSATZTEILLISTE FÜR :
SPARE PARTS LIST FOR : 1004 A - 2004 A - 2008 A - 1012 A - 2012 A - 2020 A**

REP.	DESIGNATION	BENENNUNG	SPECIFICATION	TYPES						REF. Bestell. Nr P/N :	Poch. Joints Dichtungs. Minor maint.	Lot maint. Ersatzteils. Major maint.
				2020 A	2012 A	1012 A	2008 A	2004 A	1004 A			
VERSION US - US VERSION - AMERIKANISCHE AUSFÜHRUNG												
102	Embout d'aspiration NW 25	Ansaugstutzen NW 25	Inlet port NW 25	1	1	1	1	1	1	052594		
103	Embout de refoulement NW 25	Auspuffstutzen NW 25	Exhaust port NW 25	1	1	1	1	1	1	052595		
104	Joint C 3,6-D 29,3	Dichtung C 3,6-D 29,3	O-ring C 3,6-D 29,3	1	1	1	1	1	1	082122	x	
105	Joint C 3,6-D 26,2	Dichtung C 3,6-D 26,2	O-ring C 3,6-D 26,2	1	1	1	1	1	1	082120	x	
108	Moteur mono. 115/230 V 60 Hz-1800 tr/mn-	Wechselstrommotor 115/230 V 60 Hz-1800 tr/mn-	Single phase motor 115/230 V 60 Hz-1800 rpm-	1	1	1	1	1	1	voir catalogue US see us catalog siehe USA Katalog		
108	Moteur tri. 230/460 V - 60 Hz - 1800 tr/mn	Drehstrommotor 230/460 V - 60 Hz - 1800 tr/mn	Three phase motor 230/460 V - 60 Hz - 1800 rpm	1	1	1	1	1	1			
111	1/2 Manchon moteur	Küplungshälfte	Motor coupling	1	1	1	1	1	1	052684		
117	Protecteur	Schutzkappe	Protector	2	2	2	2	2	2	068000		
123	Flasque d'adaptation	Flansch	Plate	1	1	1	1	1	1	052589		
124	Embout d'adaptateur	Stützen	Nipple conection	2	2	2	2	2	2	052652		
125	Anneau de centrage NW 25	Zentrierringe	Centering ring	2	2	2	2	2	2	068189		
126	Collier de serrage	Spanning	Quick connect clamp	2	2	2	2	2	2	083264		
129	Vis Hc - M 6 x 10	Schraube Hc - M 6 x 10	Screw Hc - M 6 x 10	1	1	1	1	1	1	075034		
VERSION JAPON - JAPANESE VERSION - JAPANISCHE AUSFÜHRUNG												
102	Embout d'aspiration NW 25	Ansaugstutzen NW 25	Inlet port NW 25	1	1	1	1	1	1	052594		
103	Embout de refoulement NW 25	Auspuffstutzen NW 25	Exhaust port NW 25	1	1	1	1	1	1	052754		
104	Joint C 3,6-D 29,3	Dichtung C 3,6-D 29,3	O-ring C 3,6-D 29,3	1	1	1	1	1	1	082122	x	
105	Joint C 3,6-D 26,2	Dichtung C 3,6-D 26,2	O-ring C 3,6-D 26,2	1	1	1	1	1	1	082120	x	
108	Moteur	Motor	Motor	voir catalogue see catalog siehe Katalog								
111	1/2 Manchon moteur	Küplungshälfte	Motor coupling	1	1	1	1	1	1	052554		
117	Protecteur	Schutzkappe	Protector	2	2	2	2	2	2	068000		
116	Joint torique C 5-D 28	Dichtung C 5-D 28	O-ring C 5-D 28	1	1	1	1	1	1	079238	x	
124	Embout d'adaptateur	Stützen	Nipple conection	2	2	2	2	2	2	052652		
125	Anneau de centrage NW 25	Zentrierringe	Centering ring	2	2	2	2	2	2	068189		
126	Collier de serrage	Spanning	Quick connect clamp	2	2	2	2	2	2	083264		
129	Vis Hc - M 6 x 10	Schraube Hc - M 6 x 10	Screw Hc - M 6 x 10	1	1	1	1	1	1	075034		