

# Agilent IDP-15 Dry Scroll Vacuum Pump

Data sheet



The new Agilent IDP-15 Dry Scroll Vacuum pump is designed for extremely quiet (<50 dBA) and low vibration operation, delivering a peak Pumping Speed of 15.4 m<sup>3</sup>/h at 60Hz; 12.8 m<sup>3</sup>/h at 50Hz.

The hermetic design with the vacuum space completely isolated from the motor and bearings provides a clean gas path through the pump, which eliminates any risk of oil or grease contamination.

## Technical Specifications

Peak pumping speed:	60 Hz: 256 L/m, 15.4 m <sup>3</sup> /hr 50 Hz: 214 L/m, 12.8 m <sup>3</sup> /hr
Media:	Not suitable for use with corrosive, explosive or particulate-forming gases
Ultimate pressure:	10 x 10 <sup>-3</sup> Torr (13.3 x 10 <sup>-3</sup> mbar)
Maximum inlet pressure:	1.0 atmosphere (0 psig)
Maximum outlet pressure:	6.5 psig
Inlet connection:	NW25
Exhaust connection:	NW16
Gas ballast:	1/4" NPTF (two positions)
Water vapor handling per Pneurop 6602:	Gas Ballast Position 1: 20.7 g/hr Gas Ballast Position 2: 235 g/hr
Ambient operating temp.:	5 °C to 45 °C (41 °F to 113 °F)
Storage temperature:	-20 °C to 60 °C (-4 °F to 140 °F)
Motor rating:	0.75 HP (560 W)
Operating voltages:	1ø / 100 VAC, 50/60 Hz 1ø / 115 VAC, 60 Hz 1ø / 220-230 VAC, 50/60 Hz
Motor thermal protection:	Automatic thermal protection
Operating speed:	60 Hz: 1725 RPM, 50 Hz: 1450 RPM
Cooling system:	Air-cooled
Pump weight:	34 kg (75 lbs)
Shipping weight:	45 kg (100 lbs)
Dimensions:	364mm (14.3") h x 333mm (13.1") w x 485mm (19.1") l
Leak rate*	<1 x 10 <sup>-6</sup> sccs helium
Vibration level at inlet	< 9 mms <sup>-1</sup> rms
Noise level	50 dBA ± 2dBA
Conformance standards	CE, CSA, RoHS

\*(with exhaust and gas ballast sealed)

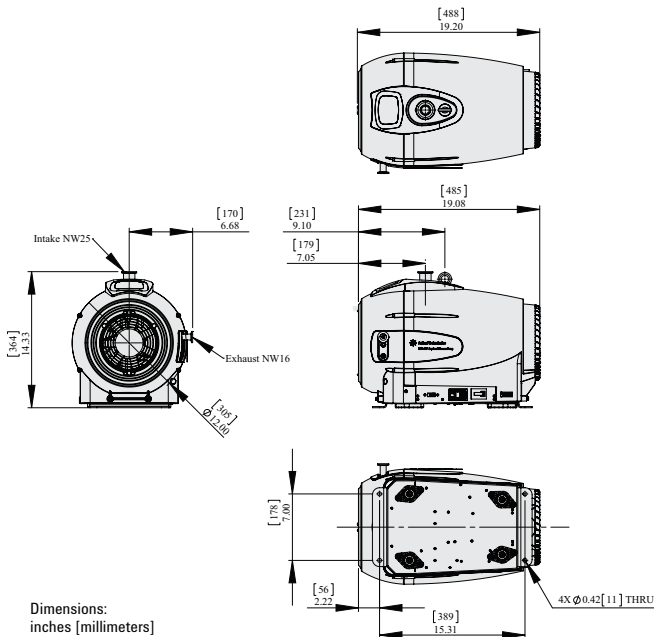

# Agilent IDP-15 Dry Scroll Vacuum Pump

## Data sheet

### Ordering Information

#### Pump Part Numbers

X3815-64000	IDP15 Scroll Pump, Std
X3815-64010	IDP15 Scroll Pump, Std w/inlt vlv

#### Service Part Numbers

X3815-67000	IDP-15 Tip Seal Replacement Kit
-------------	---------------------------------

#### Spares Part Numbers

X3815-67001	Shipping Box Set, IDP-15
-------------	--------------------------

#### Accessories:

SCRINTRPNW25	Inlet Trap, NW25, HEPA
EXSLRSH110	Exhaust Silencer Kit, SH110

#### Line Cords:

656494220	Europe, 10A/220-230V, 2.5 meter
656494225	Denmark, 10A/220-230V, 2.5 meter
656494235	Switzerland, 10A/230V, 2.5 meter
656494250	UK/Ireland, 13A/230V, 2.5 meter
656494245	India, 10A/220-250V, 2.5 meter
656494230	Isreal, 10A/220-230V, 2.5 meter
656494240	Japan, 12A/100V, 2.3 meter
656458203	North America, 15A/125V, 2.0 meter
656494255	North America, 10A/230V, 2.5 meter

### Pumping Speed

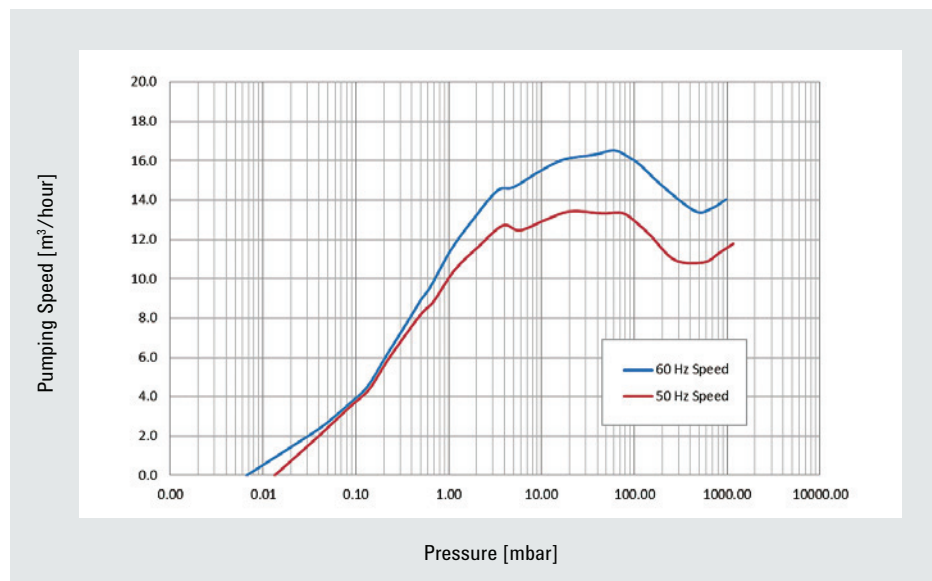

#### North and South America

Agilent Technologies  
 121 Hartwell Avenue, Lexington MA 02421, USA  
 Tel: +1 781 861 7200, Fax: +1 781 860 5437  
 Toll free: +1 800 882 7426  
[vpl-customerservice@agilent.com](mailto:vpl-customerservice@agilent.com)

#### Europe and other countries

Agilent Technologies Italia SpA  
 via F.lli Varian 54, 10040 Leini, (Torino), Italy  
 Tel: +39 011 9979 111, Fax: +39 011 9979 350  
 Toll free: 00 800 234 234 00  
[vpt-customerservice@agilent.com](mailto:vpt-customerservice@agilent.com)

Scan the QR code  
 with your smartphone  
 for more information



This information is subject to change without notice.

© Agilent Technologies, Inc. 2013  
 Published in Italy, Aug, 2013



**Agilent Technologies**