



**Series 910 DualTrans™
Transducer**

***Operation and
Maintenance Manual***



Series 910 DualTrans™ Transducer

January, 2003
Part # 100013085

Part # _____ - _____

Please fill in the transducer part and flange type numbers in the space above and have them readily available when calling for service or additional information.

(The part number can be found on your packing slip. Both the part number and serial number are located on the bottom side of the housing.)

For more information or literature, contact:

HPS® Products of MKS Instruments, Inc.
5330 Sterling Drive
Boulder, CO 80301 USA

Phone: 1-303-449-9861
1-800-345-1967

Fax: 1-303-442-6880

Web: www.mksinst.com/hpshome.html

For technical support, contact:

HPS® Products of MKS Instruments, Inc., Denmark Office
Nordre Strandvej 119 G, 3150 Hellebaek Denmark

Phone: +45 44929299

Fax: +45 44929499

©2002 by HPS® Products of MKS Instruments, Inc.
All rights reserved.

VCR® is a registered trademark of Swagelok® Company.

Table of Contents

Package Contents	7
Symbols Used in this Manual	8
Safety Precautions	9
General Specifications	10
Feature and Control Locations	11
About the 910 DualTrans™	12
Typical Applications for the 910 DualTrans™	13
Installing the 910 DualTrans™	14
Transducer Installation	14
Location	14
Orientation	14
Contamination	14
Vacuum Connection	14
Electrical Connection	15
Input/Output Wiring	15
910 DualTrans™ Electrical Connections Table	16
Relay Inductive Loads and Arc Suppression	17
Pressure Reading	17
Operation	18
910 DualTrans™ Factory Defaults Table	18
RS-485 Protocol	19
Standard Addresses	19
Universal Addresses	19
Query and Command Syntax	19
Response Syntax (ACK/NAK)	20
RS-485 Command Set	21
Set Up Commands	21
Address – AD	21
Baud Rate – BR	21
Factory Default – FD	21
RS Delay – RSD	22
Test RS485 – TST	22
Unit – U	22
User Tag – UT	22
Status Commands	23
Device Type – DT	23
Firmware Version – FV	23
Hardware Version – HV	23
Manufacturer – MF	23

Model – MD	23
Pressure Reading – PR1, PR2	23
Serial Number – SN	24
Time On – TIM	24
Transducer Temperature – TEM	24
Set Point Commands	25
Set Point Value – SP1, SP2, SP3	25
Hysteresis Value – SH1, SH2, SH3	25
Set Point Direction – SD1, SD2, SD3	26
Enable Set Point – EN1, EN2, EN3	27
Set Point Status – SS1, SS2, SS3	27
Calibration Commands	28
Atmosphere Span Calibration – SPN	28
Atmosphere Zero Calibration – ZER	28
Atmospheric Calibration – ATM	28
Gas Type Calibration – GT	29
Vacuum Calibration – VAC	28
Analog Output	30
Pressure to Voltage Table	30
Manual Procedures for the 910 DualTrans™	32
Calibrating for Zero	32
Venting to Atmosphere	32
Leak Detection	30
Maintenance and Troubleshooting	32
Maintenance and Troubleshooting Table	34
Cleaning the 910 DualTrans™ Case and Sensor Tube	35
Accessories and Part Replacement	36
Warranty	38
Appendix: How the 910 DualTrans™ Works	39
Pirani	39
MicroPirani	40
Piezo	41

Package Contents

Before unpacking the 910 DualTrans™ Transducer, check all surfaces of the packing material for shipping damage.

Confirm that the 910 DualTrans™ package contains these items:

- ◆ 1 910 DualTrans™ unit (integrated sensor and electronics)
- ◆ 1 910 DualTrans™ *Transducer Operation and Maintenance Manual*

Inspect the components for visible evidence of damage during shipment. If anything has been damaged, notify the carrier immediately. Keep all shipping materials and packaging for claim verification.



If any items are missing from the package, call MKS Customer Service at 1-303-449-9861 or 1-800-345-1967.

Do not return the product to MKS unless specified to do so by MKS Customer Service.

MKS customer service and support:

MKS Instruments, Inc.	Telephone	1-303- 449-9861
5330 Sterling Dr.	Toll-Free	1-800-345-1967 (USA only)
Boulder, CO 80301	Facsimile	1-303- 449-2003
USA		

Europe:

MKS Instruments Inc.	Telephone	+45 44 92 92 99
Nordre Strandvej 119 G	Facsimile	+45 44 92 94 99
DK-3150 Hellebaek		
Denmark		

Symbols Used in this Manual



CAUTION: Refer to the manual. Failure to heed the message could result in personal injury, serious damage to the equipment, or both.



Calls attention to important procedures, practices, or conditions.

Safety Precautions



Do not substitute parts or modify instrument. Do not install substitute parts or perform any unauthorized modification to the instrument. Return the instrument to an MKS Calibration and Service Center for service and repair to ensure that all of the safety features are maintained.



Do not use the Series 910 DualTrans™ with explosive gas mixtures or gases that are combustible in air. The MicroPirani uses a thin film Nickel resistive element that is heated to a constant temperature above ambient. This could ignite explosive gas mixtures.



Properly ground the transducer. The transducer should be connected to earth ground both through the vacuum flange and the back shell of the electrical connector.



Allow only qualified technicians to service the 910 DualTrans™ transducer. Users should not remove covers, casing, or plug-in components. Injury may result. A qualified technician must perform any part replacement or internal adjustments.



Keep the unit free of contaminants. Do not allow contamination of any kind to enter the unit before or during use. Contaminants such as dust, dirt, lint, glass chips, and metal chips may permanently damage the unit.

General Specifications

Measuring range Pirani(PR1)	1x10 ⁻⁵ to 900 Torr
Measuring range Piezo(PR2)	0.1 to 1500 Torr
Measuring Range Combination(PR3)	1x10 ⁻⁵ to 1500 Torr
Accuracy Combination(PR3)	1%: Range 10 to 1000 Torr 10%: Range 10 ⁻⁴ to 10 Torr
Repeatability of Combination (PR3)	1%: Range 10 ⁻² to 1000 Torr 5%: Range 10 ⁻³ to 1000 Torr 10%: Range 10 ⁻⁴ to 1000 Torr
Setpoint Range Comb(PR3)	1x10 ⁻⁴ to 1500 Torr
Analog out Pirani	1 to 9 VDC
Maximum pressure	1500 Torr
Supply voltage	9 to 30 VDC
Power consumption	<1.5 Watts
Fuse (recoverable)	200mA
Relay contact rating	1A @ 30 VAC/VDC resistive load
Materials exposed to vacuum	304 stainless steel, Silicon, SiO ₂ , SiN ₄ , gold, Ultem® 1000, Viton®
Housing material	304 stainless steel
Internal volume	0.6 cm ³
Operating temperature	0 to 40 °C
Bakeout temperature (off)	85°C
Installation orientation	Any
CE Certification	EMC Directive 89/336/EEC
Vacuum connections	NW16 KF, 4 VCR® F, 8 VCR® F
Dimensions (with KF 16)	1.6" x 1.6" x 3.9" (40.6 x 40.6 x 99 mm)
Weight (with KF 16)	3.4 oz. (97 g)

Feature and Control Locations

User access is through the 15-pin D-sub connector. The **ZERO** adjust button allows the user to manually perform zero calibration. See **Calibration Commands** in the **RS-485 Command Set** section for more information.

The figures below show the front and top view of the 910.

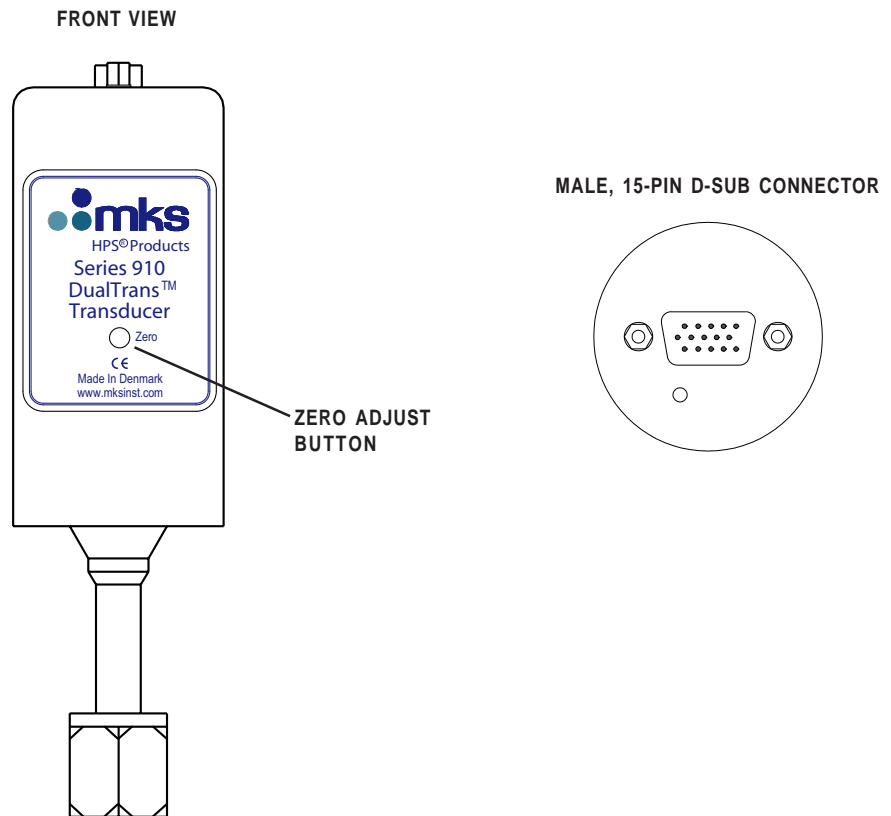

About the 910 DualTrans™

The 910 DualTrans™ is designed specifically for the semiconductor OEM environment. It combines an absolute Piezo sensor as an accurate atmospheric pressure sensor and a MicroPirani sensor to measure vacuum pressure with integrated electronic control circuits. Once integrated into the vacuum system, the 910 DualTrans™ functions are computer-controlled, requiring little manual intervention by the user. This enables the system to monitor pressure as a procedure invisible to the user, and when the desired pressure is reached, trigger the next event in the system process. This manual describes the installation and configuration tasks necessary to set up the 910 DualTrans™. After the device is set up, a software engineer at the user's installation would use the communications protocol described in this manual to create a software program (in, for example, Visual Basic, C, or C++) that will automatically control DualTrans™ operation.

For additional information on how the 910 DualTrans™ works, see the appendix **How the 910 DualTrans™**.



Typical Applications for the 910 DualTrans™

- ◆ Semiconductor applications.
- ◆ Measure foreline and roughing pressures generated by mechanical vacuum pumps.
- ◆ Control valves and pumps to automate pump-down using relay set points.
- ◆ Sense abnormal pressure and take appropriate security measures using relay set points.
- ◆ Control system pressure using digital communications or an analog output as an input to an automatic pressure controller.
- ◆ Start or stop system processes with a relay set point.
- ◆ Measure pressures of backfilling gases in the range of 10^{-4} Torr to atmosphere.
- ◆ Activate high vacuum gauges in their operating range.

Installing the 910 DualTrans™

Transducer Installation

Location

Locate the DualTrans™ where it can measure chamber or manifold pressure. Install it away from pumps and gas sources and where vibration is minimal to give the most representative pressure measurement.

Orientation

The 910 DualTrans™ can be mounted in any orientation. The MicroPirani sensor was designed to minimize convection so that the operation is possible in any position without compromising accuracy.

Contamination

Locate and orient the DualTrans™ where contamination is least likely. For example, if the DualTrans™ is installed directly above a roughing pump in the system, oil vapor could contaminate the MicroPirani's filament wire and cause the emissivity and calibration to shift. The MicroPirani sensor has a low filament temperature of only 35°C above ambient temperature; therefore, the MicroPirani is less prone to contamination by cracking products from fore-pump oil. The MicroPirani is not intended for use in corrosive environments.

Whenever possible, install the DualTrans™ with the vacuum port facing down to keep particulates or liquids from entering the device.

Vacuum Connection

Standard DualTrans™ vacuum interfaces are shown on the following page. When fitting a 1/8" NPT-M thread, do not use the case for tightening. The vacuum tubing has 9/16" hex flats for tightening. Wrap a layer of Teflon tape on the threads of the tubing, in the direction of the installation, to ensure a leak-free seal. This sensor can also use a 1/2" O-ring compression seal acting on the tubing above the thread, but the O-ring seal cannot be used for positive pressure applications.

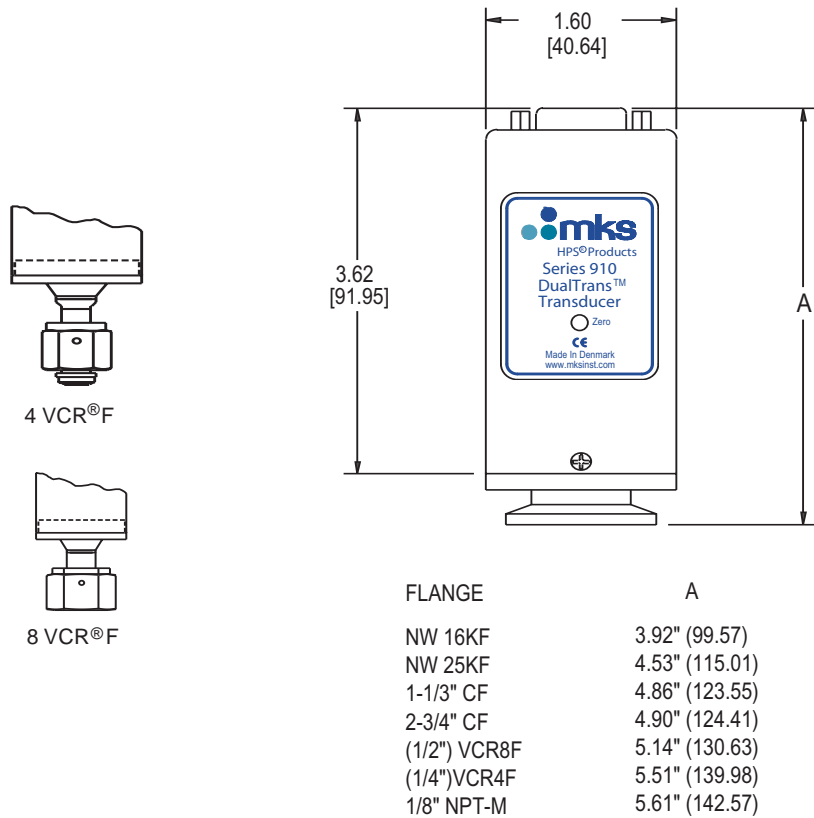

Electrical Connection

Use a cable with a female 15-pin high-density D-sub connector with strain reliefs to ensure proper electrical connection and to reduce stress on the connectors.



Ensure a low impedance electrical connection between the 910 sensor body and the grounded vacuum system to shield the sensor from external electromagnetic sources.

Input/Output Wiring

The figure and the **910 DualTrans™ Electrical Connections Table** on the following page identify the pins of the 910 connector and their functions; make a cable using this information. To comply with EN61326-1 immunity requirements, use a braided, shielded cable. Connect the braid to the metal hoods at both ends of the cable with the end for power supply connected to earth ground.

The power supply input is 9 to 30 VDC. The positive side of the power supply is connected to pin 3 and the negative side to pin 4 of the male D-sub connector. The power supply input is protected by an internal fuse. The fuse is self-recoverable; do not replace it.



Damage may occur to the circuitry if excessive voltage is applied, polarity reversed, or if a wrong connection is made.

If using analog output (described in the **Analog Output** section), the analog output voltages are pins 5 (+) and 6 (-). Connect them to a differential input voltmeter or an analog-to-digital (A/D) converter with a differential input in a system controller.



Do not connect the negative side of the analog output (pin 6) to the negative side of the power supply input (pin 4) or to any other ground. Doing so will cause half of the power current to flow through this wire. Measurement errors in the output voltage may be seen due to the voltage drop from this current. The longer the cable, the worse the error will be.



Do not connect the set point relay terminals to the analog output.

910 DualTrans™ Electrical Connections Table

The digital communications connections are pins 1 and 2. RS-485 uses pin 1 for RS485(-) and pin 2 for RS485(+). RS-232 uses pin 1 for RS232 transmit (TXD) and pin 2 for RS232 receive (RXD).

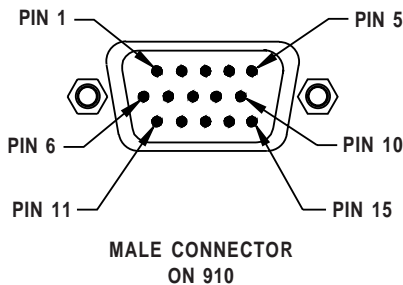

PIN	DESCRIPTION
1	RS485 - / RS232 TXD (transmit)
2	RS485 + / RS232 RXD (receive)
3	POWER +
4	POWER -
5	ANALOG OUT +
6	ANALOG OUT -
7	RELAY 1 N.O.
8	RELAY 1 COMMON
9	RELAY 1 N.C.
10	RELAY 2 N.C.
11	RELAY 2 COMMON
12	RELAY 2 N.O.
13	RELAY 3 N.C.
14	RELAY 3 COMMON
15	RELAY 3 N.O.

Relay Inductive Loads and Arc Suppression

If using the set point relay to switch inductive loads (e.g., solenoids, relays, transformers, etc.), the arcing of the relay contacts might interfere with 910 operation and reduce relay contact life. Therefore, an arc suppression network, shown schematically below, is recommended.

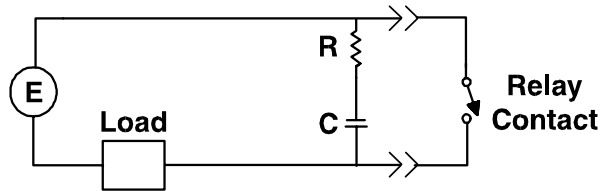

The values of the capacitance C and the resistance R can be calculated by the following equations:

$$C = I^2 / (1 \times 10^7)$$

$$R = E / I^a$$

where:

C is in farads

R is in ohms

I is DC or AC_{peak} load current in amperes

E is DC or AC_{peak} source voltage in volts

$a = 1 + (50 / E)$

Note that $R_{min} = 0.5 \Omega$ and $C_{min} = 1.0 \times 10^{-9} F$

Pressure Reading

The MicroPirani is based on measurement of thermal conductivity; therefore, the MicroPirani readout depends on the gas type and concentration.

Operation

The 910 DualTrans™ operation parameters are preset at the factory. The table below shows the factory default settings. Use the user interface and the commands described on the following pages to change parameter settings as necessary. The user interface to the 910 DualTrans™ is through either RS-232 or RS-485 serial communications. RS-232 and RS-485 use the same commands to communicate with the 910; however, RS-485 allows communication with multiple transducers, whereas RS-232 allows communication with only a single transducer. The remainder of this manual refers to RS-485 only.

910 DualTrans™ Factory Defaults Table

Setting	Default
Address	253
Baud Rate	9600
Pressure Units	Torr
Set Point 1, 2, 3	1.00E0 Torr
Hysteresis 1, 2, 3	1.10E0 Torr
Set Point Direction	Below
Enable Set Point	Off
Gas Type	Nitrogen

RS-485 Protocol

The 910 supports 2400, 4800, 9600, and 19200 baud rates (factory default: 9600). The data format is 8 data bits, no parity, and one stop bit.

Standard Addresses

Valid addresses are 3 digits, 001 to 253 (factory default: 253).

Universal Addresses

The 910 receives and responds to commands sent to address 254. For example, use 254 to communicate with a device if its address is unknown. The 910 receives and acts upon commands sent to address 255, but does not respond; use 255 to broadcast messages to multiple devices attached to the same system. For example, use 255 to change the baud rate for all devices.

Query and Command Syntax

Queries return current parameter settings; commands change the parameter setting according to the value the user types in the command syntax. Each query or command must begin with the attention character @ and end with the termination string ;FF.

Syntax required for a query is:

@<device address><query>?;FF.

Syntax required for a command is:

@<device address><command>!<parameter>;FF.

Examples:

Query current baud rate: @253BR?;FF

Change baud rate to 19200: @253BR!19200;FF

where:

@	<attention character>
253	<device address>
BR?	<query> (for query syntax)
BR!19200	<command>!<parameter> (for command syntax)
;FF	<terminator>

Response Syntax (ACK/NAK)

The ASCII characters 'ACK' or 'NAK' preface the query or command response string. The ACK sequence signifies the message was processed successfully. The NAK sequence indicates there was an error.

The response to a query or a successful command is:

@<device address>ACK<data>;FF

The response to a message with an error is:

@<device address>NAK;FF

Examples:

ACK response: @253ACK9600;FF (baud rate changed to 9600)

NAK response: @253NAK;FF

RS-485 Command Set

The query and command formats shown in this section are examples; the values may vary for the user's installation.

Set Up Commands

Address – AD

The AD command returns or sets the 910 address. Note: If multiple devices are installed on the system, an address query using 254 (shown in the query example below) cannot determine the address of only one of the devices.

Values: 001 to 253 (default: 253)

Query: @254AD?;FF
Query Response: @001ACK001;FF
Command: @001AD!002;FF
Command Response: @002ACK002;FF

Baud Rate – BR

The BR command returns or sets the baud rate of the communications protocol. The 910 responds to this command at the present baud rate; however, the user will need to change the baud rate on the host to ensure future commands are sent at the same rate.

Values: 2400, 4800, 9600, 19200 (default: 9600)

Query: @001BR?;FF
Query Response: @001ACK9600;FF
Command: @001BR!19200;FF
Command Response: @001ACK19200;FF

Factory Default – FD

The FD command sets all 910 parameter values to the factory default settings shown in the **910 DualTrans™ Factory Defaults Table** (page 18). Note: The FD command overrides all parameter values the user sets; use with caution! The address and baud rate reset to 253 and 9600, respectively. The user must change the address and baud rate to these values on the host to communicate with the transducer after using the FD command.

Command: @001FD!;FF
Command Response: @001ACKFD;FF

RS Delay – RSD

The RSD command enables or disables a delay of up to 5 milliseconds between receive and transmit mode. The delay is required in some half duplex applications like RS232 to RS485 converters.

Values: OFF, ON (default OFF)

Query: @001RSD?;FF
Query Response: @001ACKOFF;FF
Command: @001RSD!ON;FF
Command Response: @001ACKON;FF

Test RS485 – TST

The TST command flashes the transducer power LED ON and OFF, in order to visually identify the unit.

Values: ON, OFF

Query: @001TST?;FF
Query Response: @001ACKOFF;FF
Command: @001TST!ON;FF
Command Response: @001ACKON;FF

Unit – U

The U command returns or sets the pressure unit to Torr, mBar, or Pascal. The units affect all pressure measurements, including set point values.

Values: TORR, MBAR, PASCAL (default: TORR)

Query: @001U?;FF
Query Response: @001ACKTORR;FF
Command: @001U!MBAR;FF
Command Response: @001ACKMBAR;FF

User Tag – UT

The UT command returns or sets the user tag label to assign for 910 identification.

Values: Up to 15 ASCII characters

Query: @001UT?;FF
Query Response: @001ACKCHAMBER1;FF
Command: @001UT!CHAMBER2;FF
Command Response: @001ACKCHAMBER2;FF

Status Commands

Device Type – DT

The DT command returns the transducer device type.

Query: @001DT?;FF
Query Response: @001ACKDUALTRANS;FF

Firmware Version – FV

The FV command returns the 910 firmware version.

Query: @001FV?;FF
Query Response: @001ACK1.00;FF

Hardware Version – HV

The HV command returns the 910 hardware version.

Query: @001HV?;FF
Query Response: @001ACK1.00;FF

Manufacturer – MF

The MF command returns the 910 manufacturer.

Query: @001MF?;FF
Query Response: @001ACKHPS;FF

Model – MD

The MD command returns the 910 model number.

Query: @001MD?;FF
Query Response: @001ACK901;FF

Pressure Reading – PR1, PR2, PR3, PR4, PR5

Pressure Reading-PR1

The PR1 pressure reading command return the measured pressure by the MicroPirani sensor.

Pressure Reading PR-2

The PR2 pressure reading command return the measured pressure by the Piezo sensor.

Pressure Reading PR-3

The pressure reading command return the combined measured pressure by the MicroPirani and Piezo sensor. The reading is smoothed linked in the range from 5 to 15 Torr.

Pressure Reading PR-4

The PR4 is a high resolution combined reading as the PR3.

Pressure Reading PR5

PR5 measures the differential value between PR1 MicroPirani reading and PR2 Piezo reading. This command can be used for leak detection.

Serial Number – SN

The SN command returns the 910 serial number.

Query: @001SN?;FF
Query Response: @001ACK000012345;FF

Time On – TIM

The TIM command returns the number of hours the transducer has been on.

Query: @001TIM?;FF
Query Response: @001ACK000000024;FF

Transducer Temperature – TEM

The TEM command returns the MicroPirani's on-chip sensor temperature in °C.

Query: @001TEM?;FF
Query Response: @001ACK2.10E+1;FF

Set Point Commands

The 910 has three independent set point relays for control. The relays can be enabled or disabled with the **Enable Set Point – EN1, EN2, EN3** command (next page).

Set Point Value – SP1, SP2, SP3

The set point value command returns or sets the set point value. The set point value is the pressure either below or above which the set point relay will be energized (i.e., N.O. and C contacts will be closed). The direction of the set point (ABOVE or BELOW) is configured using the **Set Point Direction – SD1, SD2, SD3** command. The set point must be enabled for the set point command to function (see the **Enable Set Point – EN1, EN2, EN3** command). Whenever the set point value is changed the set point hysteresis is automatically set to +10% of set point value if set point direction is below and -10% of set point value if set point direction is above.

Values: Two- or three-digit scientific notation
(default: 1.00E0 Torr)

Query: @001SP1?;FF
Query Response: @001ACK1.00E-2;FF
Command: @001SP1!1.00E-3;FF
Command Response: @001ACK1.00E-3;FF

Hysteresis Value – SH1, SH2, SH3

The hysteresis value command returns or sets the pressure value at which the set point relay will be de-energized (i.e., N.C. and C contacts will be closed). If the hysteresis and set point are the same value, or nearly the same value, the relay may chatter when the system pressure is near the set point. The set point hysteresis is automatically set to +10% of set point value if set point direction is below and -10% of set point value if set point direction is above. The set point hysteresis is overwritten if set point direction is changed or if set point value is changed.

Values: Two- or three-digit scientific notation
(default: 1.00E0 Torr)

Query: @001SH1?;FF
Query Response: @001ACK1.10E-2;FF
Command: @001SH1!1.10E-3;FF
Command Response: @001ACK1.10E-3;FF

Set Point Direction – SD1, SD2, SD3

The set point direction command returns or sets the direction of the set point. BELOW sets the relay when the pressure is below the set point value; ABOVE sets the relay when the pressure is above the set point value. Whenever the SD command is implemented the setpoint hysteresis is automatically set to +10% of set point value if set point direction command is below and -10% of set point value is if set point direction command is above. (See **Set Point Value – SP1, SP2, SP3** and **Hysteresis Value – SH1, SH2, SH3**, above.)

Values: BELOW, ABOVE (default: BELOW)

Query: @001SD1?;FF
Query Response: @001ACKBELOW;FF
Command: @001SD1!ABOVE;FF
Command: @001ACKABOVE;FF

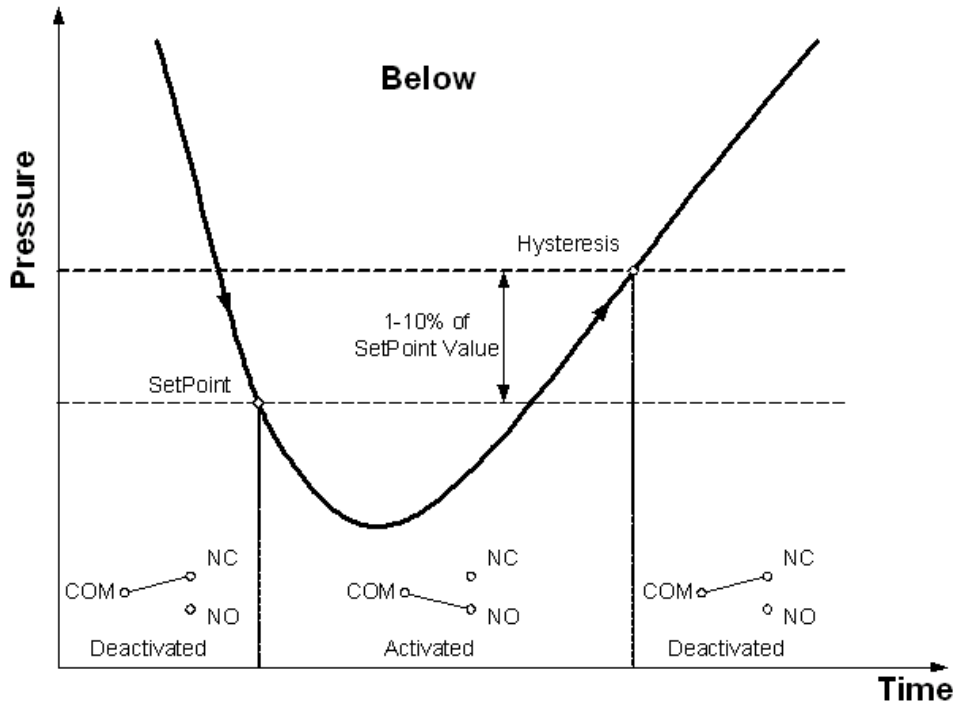

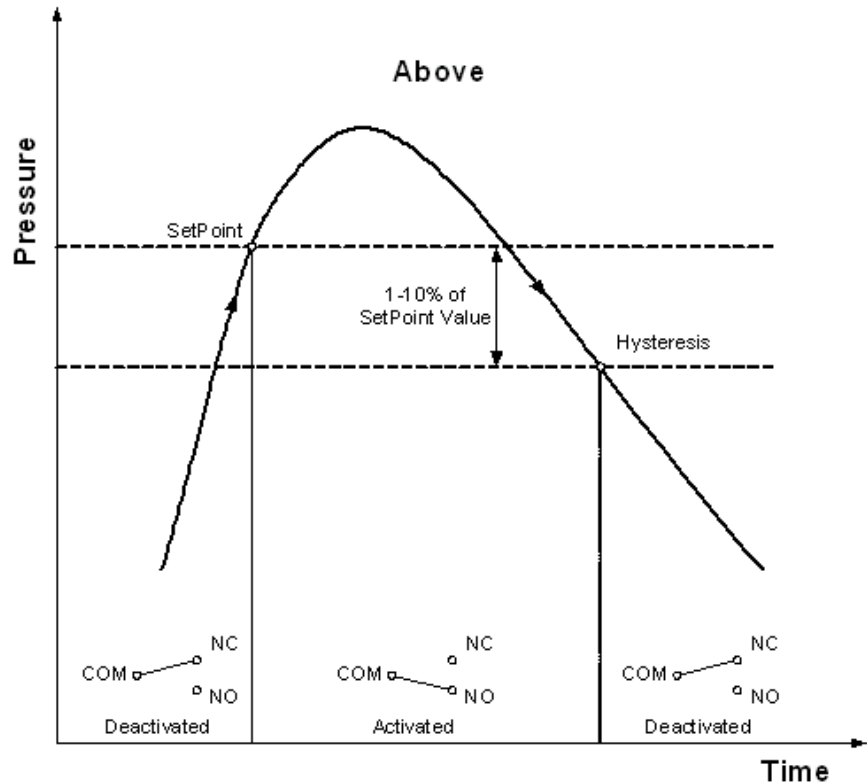

Enable Set Point – EN1, EN2, EN3

The enable set point command returns enable status or disables the set point relay. The setpoint are always associated with the combination output (PR3).

Values: ON,OFF (default: OFF)

Query: @001EN1?;FF

Query Response: @001ACKOFF;FF

Command: @001EN1!ON;FF

Command: @001ACKON;FF

Set Point Status – SS1, SS2, SS3

The set point status command returns the status of the set point relay.

Values: SET, CLEAR

Query: @001SS1?;FF

Query Response: @001ACKCLEAR;FF

Calibration Commands

Span Calibration – SPN

The SPN command sets full scale span for the Piezo. Enter the applied full scale calibration pressure in the range from 100 to 1000 Torr.

Values: Pressure value in scientific notation

Command: @001SPN!1.00E+2;FF

Command Response: @001ACK1.00E+2;FF

Zero Calibration – ZER

The ZER command sets the zero adjustment of the Piezo. Place the transducer in at a pressure below 1×10^{-2} Torr before performing zero calibration.

Command: @001ZER!;FF

Command Response: @001ACKZER;FF

Atmospheric Calibration – ATM

The ATM command sets full scale readout for the MicroPirani. Vent the transducer to atmospheric pressure before performing atmospheric calibration. Optionally, the user can manually vent to atmosphere, as described in the section **Venting to Atmosphere**.

Values: Pressure value in scientific notation

Command: @001ATM!7.60E+2;FF

Command Response: @001ACK7.60E+2;FF

Vacuum Calibration – VAC

The VAC command zeroes the MicroPirani readout. Evacuate the transducer to a pressure below 8×10^{-6} Torr before performing vacuum calibration. Optionally, the user can calibrate for zero by pressing the **ZERO** button on the top of the DualTrans™, as described in the section **Calibrating for Zero**.

Command: @001VAC!;FF

Command Response: @001ACKVAC;FF

Gas Type Calibration – GT

The GT command sets gas type for measurement. The MicroPirani measures thermal conductivity; using the gas calibration compensates for gas errors.

Values: NITROGEN, AIR, ARGON, HYDROGEN, HELIUM,
H₂O (default: NITROGEN)

Query: @001GT?;FF
Query Response: @001ACKAIR;FF
Command: @001GT!NITROGEN;FF
Command Response: @001ACKNITROGEN;FF

Analog Output

The analog output voltage is derived from the combination output (PR3). The analog voltage signals are pins 5 (+) and 6 (-). Connect them to a differential input. The transducer provides an analog output of 1 VDC per decade. The minimum output voltage is 1 VDC at 1×10^{-5} Torr.



Do not connect the negative side of the analog output (pin 6) to the power supply return (pin 4) or to any other ground. The voltage drop from the supply current will produce errors in the analog output voltage. The longer the cable, the worse the error will be.

The graph below shows the correlation of linear analog output to pressure.

To calculate pressure from voltage: $P \text{ (Torr)} = 10^{(V-6)}$

Output Voltage vs. Pressure

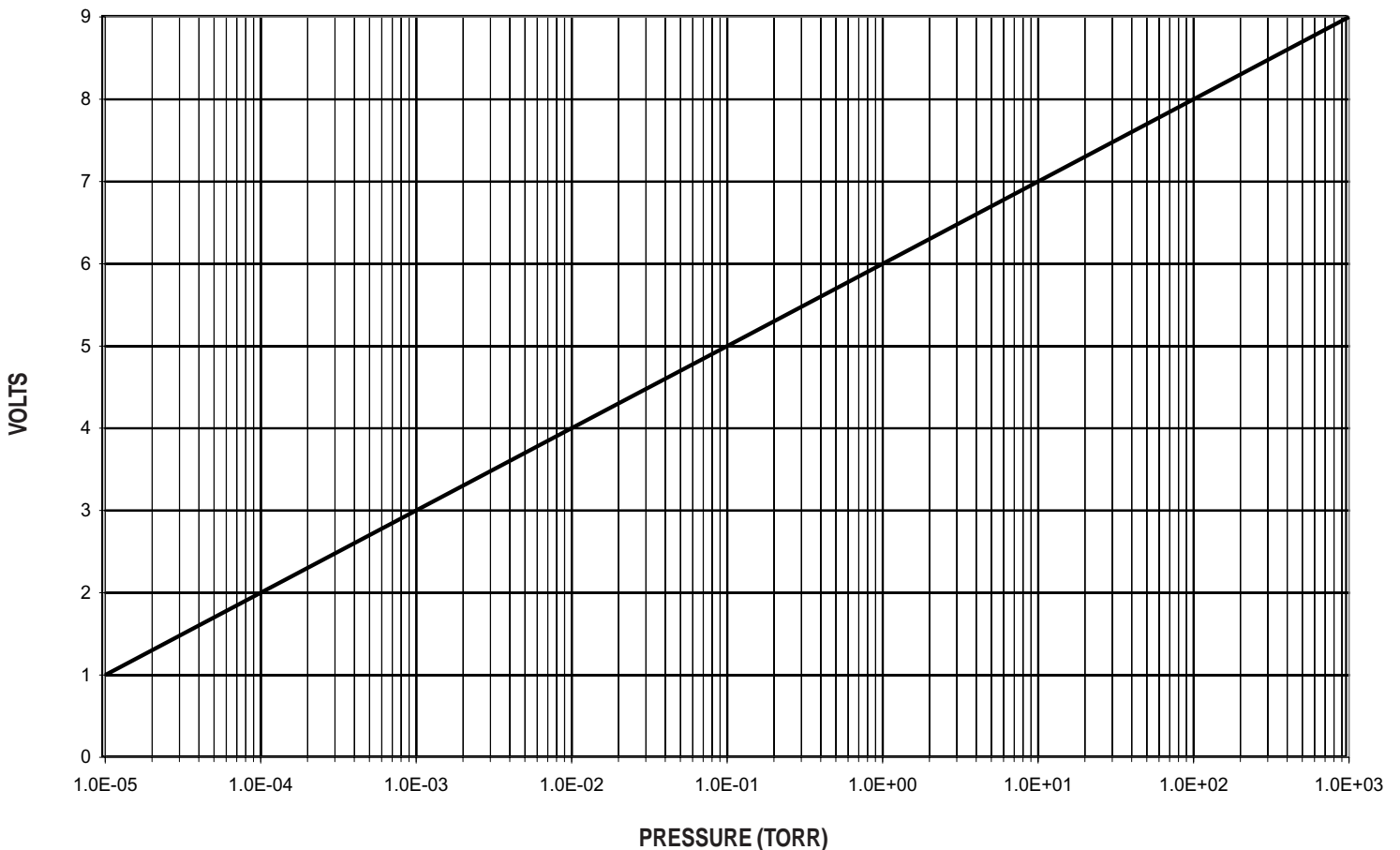

Pressure to Voltage Table

Pressure (Torr)	Volts	Pressure (Torr)	Volts
1.0×10^{-5}	1.00	1.0×10^{-1}	5.00
2.0×10^{-5}	1.30	2.0×10^{-1}	5.30
4.0×10^{-5}	1.60	4.0×10^{-1}	5.60
6.0×10^{-5}	1.77	6.0×10^{-1}	5.77
8.0×10^{-5}	1.90	8.0×10^{-1}	5.90
1.0×10^{-4}	2.00	1.0×10^0	6.00
2.0×10^{-4}	2.30	2.0×10^0	6.30
4.0×10^{-4}	2.60	4.0×10^0	6.60
6.0×10^{-4}	2.77	6.0×10^0	6.77
8.0×10^{-4}	2.90	8.0×10^0	6.90
1.0×10^{-3}	3.00	$1.0 \times 10^{+1}$	7.00
2.0×10^{-3}	3.30	$2.0 \times 10^{+1}$	7.30
4.0×10^{-3}	3.60	$4.0 \times 10^{+1}$	7.60
6.0×10^{-3}	3.77	$6.0 \times 10^{+1}$	7.77
8.0×10^{-3}	3.90	$8.0 \times 10^{+1}$	7.90
1.0×10^{-2}	4.00	$1.0 \times 10^{+2}$	8.00
2.0×10^{-2}	4.30	$2.0 \times 10^{+2}$	8.30
4.0×10^{-2}	4.60	$4.0 \times 10^{+2}$	8.60
6.0×10^{-2}	4.77	$6.0 \times 10^{+2}$	8.77
8.0×10^{-2}	4.90	$8.0 \times 10^{+2}$	8.90

Manual Procedures for the 910 DualTrans™

Calibrating for Zero

Though factory calibrated, the DualTrans™'s calibration may change due to reasons such as filament contamination or aging of the electronic components. If necessary, the user can adjust zero calibration of the DualTrans™. The user can adjust zero calibration by using the **Vacuum Calibration – VAC** command, or by pressing the **ZERO** adjust button, as follows:



For best results, leave the DualTrans™ at the calibration pressure for at least 20 minutes before pressing the ZERO adjust button.

1. The analog output voltages are on pins 5 (+) and 6 (-) on the 15-pin D-sub connector. Connect them to a differential input voltmeter or an analog-to-digital (A/D) converter with a differential input in the system controller.
2. Pump the system to a pressure below 1×10^{-5} Torr. Then press the **ZERO** adjust button for a voltmeter reading of 1.00 VDC.
3. The LED will blink twice when the zero calibration is executed. THE LED will blink once if the pressure is too high for zero adjustment.

Venting to Atmosphere

The Series 910 Piezo sensor has a response time of less than 50 mSec from zero to full scale. This will allow the user to vent their system to atmosphere as quickly as necessary.

The 910 DualTrans™ sensor can be vented to atmosphere very rapidly without damage to the sensor element. This is an improvement over the traditional Pirani sensor, which uses a very small diameter filament wire, which can be broken or damaged during sudden venting to atmosphere.

Leak Detection

Its inherent sensitivity MicroPirani sensor of the to gas type makes the Series 910 DualTrans™ useful for detecting leaks, at rates greater than 10^{-4} std cc/sec of helium, in foreline and roughing systems. It is a useful complement to a mass spectrometer leak detector, which locates smaller leaks.

Probe the suspected leak areas with a gas that has a molecular weight different that of the system gas. Helium is suitable for probing a system pumping air or nitrogen.

1. Pump system to pressure not lower than 1 Torr.
2. Slowly and methodically probe with a small amount of trace gas (helium).
3. Read PR5. If value increase the probe is near the leak location.
4. Repeat the test to confirm.

Maintenance and Troubleshooting

Maintenance and Troubleshooting Table

Symptom	Possible Cause/Remedy
No response to RS-485 commands	<ul style="list-style-type: none"> - Attention character (@) missing - Address incorrect - Termination characters (;FF) missing - Baud rate incorrect - Electrical connections missing or incorrect <p>Note: If baud rate and electrical connections are correct, then @254;FF should give the response @253NAK;FF (the address may be different from 253).</p>
Vacuum pressure reading too high/too low or zero adjustment was made at the wrong pressure	Adjust zero calibration using the Vacuum Calibration – VAC command, or press the ZERO adjustment button on the device.
Atmospheric pressure too high/too low	Adjust span calibration using the SPAN Calibration – SPN command.
Set point does not trip	<ul style="list-style-type: none"> - Set point not enabled - Set point hysteresis value not set to proper value - Set point direction is different from what the user expects - Connector miswired
No analog output voltage	<ul style="list-style-type: none"> - Power supply turned off - Electrical connections missing or incorrect
First Characters are missing from responses	-Delay between receive and transmit is required. Enable RS delay RSD!ON see page 22.

Cleaning the 910 DualTrans™ Case and Sensor Tube

The finish of the 910 DualTrans™ case is designed to resist many laboratory solvents; clean the case with water or alcohol. Take care to prevent a liquid from entering the electronic enclosure.

Roughing pump oils and other fluids condensing or decomposing on the heated filament can contaminate the sensor elements. This changes the emissivity of the filament, which could in turn cause the calibration to change, especially at low pressure.



Do not attempt to clean the sensor tube. Trying to clean it may cause permanent damage to the sensor element.

Replace the sensor if it becomes contaminated.

Accessories and Part Replacement

Description

Transducer with NW16 KF flange, RS-232 comm.
Transducer with NW16 KF flange, RS-485 comm.
Transducer with 4VCR[®] F flange, RS-232 comm.
Transducer with 4VCR[®] F flange, RS-485 comm.
Transducer with 8VCR[®] F flange, RS-232 comm.
Transducer with 8VCR[®] F flange, RS-485 comm.
Operation and Maintenance Manual

Part Number

910-11
910-12
910-41
910-42
910-51
910-52
100013085

Notes:

Warranty

Extent of the Warranty

MKS Instruments, Inc. (MKS), HPS® Products, warrants the HPS® Products Series 910 DualTrans™ Transducer and its accessories to be free from defects in materials and workmanship for one (1) year from the date of shipment by MKS or authorized representative to the original purchaser (PURCHASER). Any product or parts of the product repaired or replaced by MKS under this warranty are warranted only for the remaining unexpired part of its one (1) year original warranty period. After expiration of the applicable warranty period, the PURCHASER shall be charged MKS' current prices for parts and labor, plus any transportation for any repairs or replacement.

ALL EXPRESS AND IMPLIED WARRANTIES, INCLUDING THE IMPLIED WARRANTIES OF MERCHANTABILITY AND FITNESS FOR A PARTICULAR PURPOSE, ARE LIMITED TO THE WARRANTY PERIOD. NO WARRANTIES, EXPRESS OR IMPLIED, WILL APPLY AFTER THIS PERIOD.

Warranty Service

The obligations of MKS under this warranty shall be at its option: (1) to repair, replace, or adjust the product so that it meets applicable product specifications published by MKS or (2) to refund the purchase price.

What is Not Covered

The product is subject to above terms only if located in the country of the seller from whom the product was purchased. The above warranties do not apply to:

- I. Damages or malfunctions due to failure to provide reasonable and necessary maintenance in accordance with MKS operating instructions.
- II. Damages or malfunctions due to chemical or electrolytic influences or use of the product in working environments outside the specification.
- III. Fuses and all expendable items which by their nature or limited lifetime may not function for a year. If such items fail to give reasonable service for a reasonable period of time within the warranty period of the product, they will, at the option of MKS, be repaired or replaced.
- IV. Defects or damages caused by modifications and repairs effected by the original PURCHASER or third parties not authorized in the manual.

Condition of Returned Products

MKS will not accept for repair, replacement, or credit any product which is asserted to be defective by the PURCHASER, or any product for which paid or unpaid service is desired, if the product is contaminated with potentially corrosive, reactive, harmful, or radioactive materials, gases, or chemicals. When products are used with toxic chemicals, or in an atmosphere that is dangerous to the health of humans, or is environmentally unsafe, it is the responsibility of the PURCHASER to have the product cleaned by an independent agency skilled and approved in the handling and cleaning of contaminated materials before the product will be accepted by MKS for repair and/or replacement. In the course of implementing this policy, MKS Customer Service Personnel may inquire of the PURCHASER whether the product has been contaminated with or exposed to potentially corrosive, reactive, harmful, or radioactive materials, gases, or chemicals when the PURCHASER requests a return authorization. Notwithstanding such inquiries, it is the responsibility of the PURCHASER to ensure that no products are returned to MKS which have been contaminated in the aforementioned manner.

Other Rights and Remedies

- I. These remedies are exclusive. HPS® SHALL NOT BE LIABLE FOR CONSEQUENTIAL DAMAGES, FOR ANTICIPATED OR LOST PROFITS, INCIDENTAL DAMAGES OR LOSS OF TIME, OR OTHER LOSSES INCURRED BY THE PURCHASER OR BY ANY THIRD PARTY IN CONNECTION WITH THE PRODUCT COVERED BY THIS WARRANTY, OR OTHERWISE. Some states do not allow exclusion or limitation of incidental or consequential damage or do not allow the limitation on how long an implied warranty lasts. If such laws apply, the limitations or exclusions expressed herein may not apply to PURCHASER.
- II. Unless otherwise explicitly agreed in writing, it is understood that these are the only written warranties given by HPS®. Any statement made by any persons, including representatives of MKS, which are inconsistent or in conflict with the terms of the warranty shall not be binding on MKS unless reduced to writing and approved by an authorized officer of MKS.
- III. This warranty gives PURCHASER specific legal rights, and PURCHASER may also have other rights which vary from state to state.
- IV. For MKS products sold outside of the U. S., contact your MKS representative for warranty information and service.

Warranty Performance

To obtain warranty satisfaction, contact the following: MKS Instruments, Inc., HPS® Products, 5330 Sterling Drive, Boulder, CO 80301, USA, at phone number 1-303-449-9861. You may be required to present proof of original purchase.

Appendix: How the 910 DualTrans™ Works

The Series 910 DualTrans™ Transducer is a combination of two different types of pressure sensors: the MicroPirani and the Piezo. The MicroPirani sensor measures pressure indirectly as a heat-loss manometer that infers the pressure of a gas by measuring thermal loss from a heated wire. The Piezo measures pressure directly as a force or pressure is applied to a diaphragm with a piezoresistive Wheatstone bridge network.

Pirani

The Pirani sensor is type of thermal conductivity sensor. It consists of a hot wire suspended from supports. This wire loses thermal energy in three ways:

- ◆ Thermal conduction through the gas, which is pressure dependent
- ◆ End loss to the supports
- ◆ Radiation to surrounding surfaces

Pirani sensors use pressure-dependent gas transport from a hot wire to measure pressure. End loss and radiation loss act as error signals and determine the low pressure limit of the sensor. Optimizing operational parameters of the wire length and diameter, thermal emissivity, thermal conductivity, and wire temperature can decrease end loss and radiation errors. A standard Pirani sensor usually has a lower reading limit of about 10^{-3} Torr, due to signal lost by end loss and radiation error.

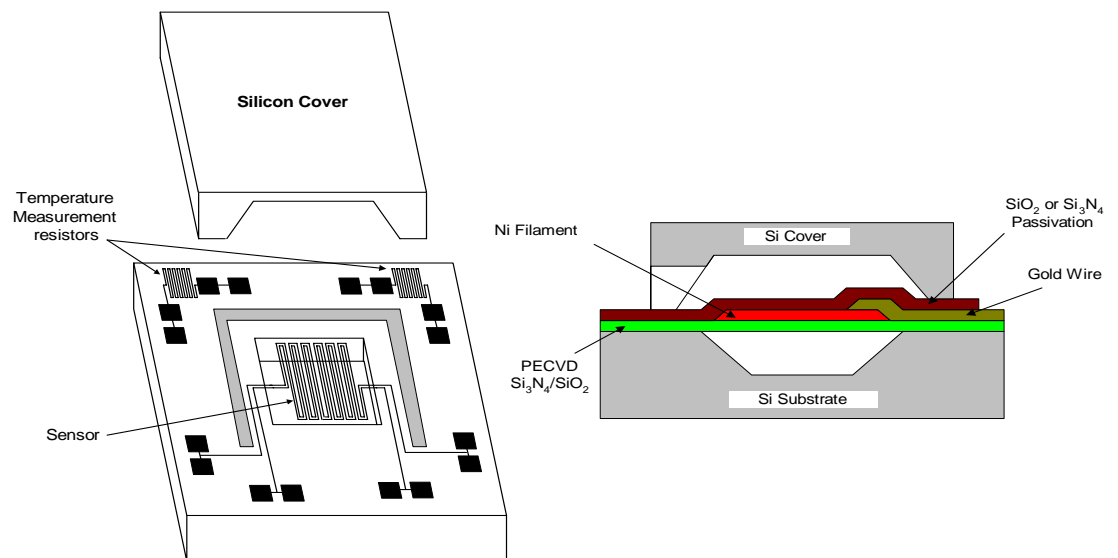

MicroPirani

The MicroPirani sensor functions the same as a traditional Pirani sensor, but instead of a heated wire, a thin film Nickel resistive element is deposited onto a silicon substrate. This heated filament is maintained at a constant temperature above the ambient temperature of the substrate. A solid-state MicroPirani sensor has several advantages over a wire based Pirani sensor. The operational parameters are controlled and optimized to decrease the end loss and radiation errors, the integrated temperature sensors improve the temperature compensation performance, and the small geometry decreases the thermal lag time, ensuring faster response time. These improvements allow the MicroPirani sensor to operate down to 10^{-5} Torr, two decades lower than traditional Pirani sensors. The smaller distance between the heated filament and the cold substrate increases the pressure measurement range in the higher-pressure regions.

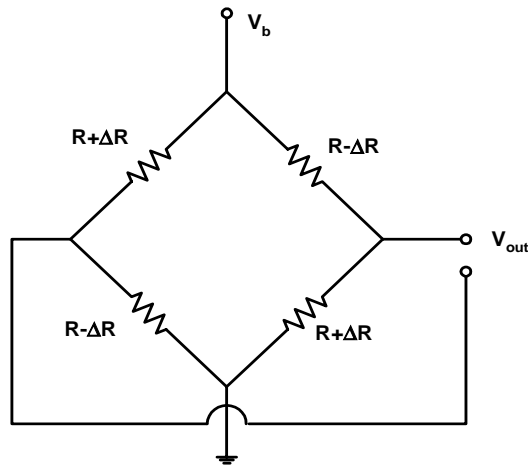
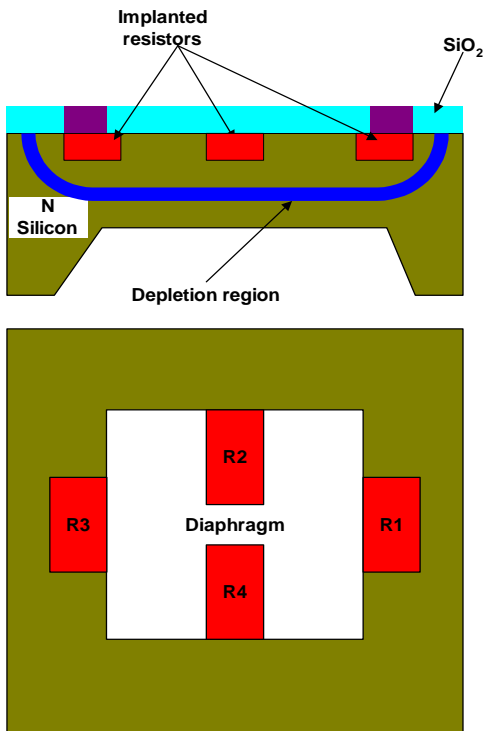

Piezo

The Piezo sensor consists of a bridge of piezoresistive elements on a diaphragm, which change their resistance proportional to the pressure applied to the sensor. The resistance change in a monocrystalline semiconductor (piezoelectric effect) is substantially higher than that in a standard strain gauge. Resistance in a doped semiconductor is changed by a compression or stretching of the crystal grid that can be produced by an extremely small mechanical deformation. The advantages of piezoresistive sensors are very high sensitivity, very good linearity and virtually no creep or hysteresis. A disadvantage with piezo sensors can be their nonlinearity with temperature, but the electronic circuitry has temperature compensation to correct these variations.

The Piezo sensors measures pressure directly and is gas type independent. The Series 910 DualTrans™ uses an absolute piezo referenced to a vacuum reference pressure.



