



**Series 902
Piezo Transducer**

***Operation and
Maintenance Manual***



Series 902 Piezo Transducer

September, 2002
Part # 100011739

Part # _____ - _____

Please fill in the transducer part and flange type numbers in the space above and have them readily available when calling for service or additional information.

(The part number can be found on your packing slip. Both the part number and serial number are located on the bottom side of the housing.)

For more information or literature, contact:

HPS® Products of MKS Instruments, Inc.
5330 Sterling Drive
Boulder, CO 80301 USA

Phone: 1-303-449-9861
1-800-345-1967

Fax: 1-303-442-6880

Web: www.mksinst.com/hpshome.html

©2002 by HPS® Products of MKS Instruments, Inc.
All rights reserved.

VCR® is a registered trademark of Swagelok® Company.

Table of Contents

Package Contents	7
Symbols Used in this Manual	8
Safety Precautions	9
General Specifications	10
Feature and Control Locations	11
902 Piezo	11
Optional Piezo Display Module	11
About the 902 Piezo	12
Typical Applications for the 902 Piezo	13
Installing the 902 Piezo	14
Transducer Installation	14
Location	14
Orientation	14
Contamination	14
Vacuum Connection	14
Electrical Connection	15
Input/Output Wiring	15
902 Piezo Electrical Connections Table	16
Relay Inductive Loads and Arc Suppression	16
Piezo Display Module Connection	17
Operation	18
902 Piezo Factory Defaults Table	18
RS-485 Protocol	19
Standard Addresses	19
Universal Addresses	19
Query and Command Syntax	19
Response Syntax (ACK/NAK)	20
RS-485 Command Set	21
Set Up Commands	21
Address – AD	21
Analog Output Format – DAC	21
Baud Rate – BR	21
Factory Default – FD	22
Unit – U	22
User Tag – UT	22
Status Commands	22
Device Type – DT	22
Firmware Version – FV	22
Hardware Version – HV	23

Manufacturer – MF	23
Model – MD	23
Pressure Reading – PR1	23
Serial Number – SN	23
Time On – TIM	23
Transducer Temperature – TEM	23
Set Point Commands	24
Set Point Value – SP1	24
Hysteresis Value – SH1	24
Set Point Direction – SD1	24
Enable Set Point – EN1	25
Set Point Status – SS1	25
Calibration Commands	25
User Zero Calibration – ZER	25
User Span Calibration – SPN	25
Analog Output	26
Linear versus Logarithmic Analog Output	26
Linear Analog Output	26
Logarithmic Analog Output	26
Linear 10	27
Linear 5	28
Logarithmic 10	29
Logarithmic 5	30
Pressure to Voltage Table	31
Maintenance and Troubleshooting	32
Maintenance and Troubleshooting Table	32
Accessories and Part Replacement	33
Warranty	34
Appendix: How the 902 Piezo Transducer Works	35

Package Contents

Before unpacking the 902 Piezo Transducer, check all surfaces of the packing material for shipping damage.

Confirm that the 902 Piezo package contains these items:

- ◆ 1 902 Piezo Transducer
- ◆ 1 *902 Piezo Transducer Operation and Maintenance Manual*

Inspect the components for visible evidence of damage during shipment. If anything has been damaged, notify the carrier immediately. Keep all shipping materials and packaging for claim verification.



If any items are missing from the package, call MKS Customer Service at 1-303-449-9861 or 1-800-345-1967.

Do not return the product to MKS unless specified to do so by MKS Customer Service.

MKS Instruments, Inc.	Telephone	1-303- 449-9861
5330 Sterling Dr.	Toll-Free	1-800-345-1967 (USA only)
Boulder, CO 80301	Facsimile	1-303- 449-2003
USA		

Symbols Used in this Manual



CAUTION: Refer to the manual. Failure to heed the message could result in personal injury, serious damage to the equipment, or both.



Calls attention to important procedures, practices, or conditions.

Safety Precautions



Do not substitute parts or modify instrument. Do not install substitute parts or perform any unauthorized modification to the instrument. Return the instrument to an MKS Calibration and Service Center for service and repair to ensure that all of the safety features are maintained.



Properly ground the transducer. The transducer should be connected to earth ground both through the vacuum flange and the back shell of the electrical connector.



Allow only qualified technicians to service the 902 Piezo transducer. Users should not remove covers, casing, or plug-in components. Injury may result. A qualified technician must perform any part replacement or internal adjustments.



Keep the unit free of contaminants. Do not allow contamination of any kind to enter the unit before or during use. Contaminants such as dust, dirt, lint, glass chips, and metal chips may permanently damage the unit.

General Specifications

Measuring range	0.1 to 1000 Torr
Set point range	1 to 1000 Torr
Analog out	0 to 5 VDC 0 to 10 VDC
Maximum pressure	2000 Torr
Accuracy	1.0% Reading
Repeatability	± 0.03% FS
Temperature effect on span	± 0.02% FS/ °C
Temperature effect on zero	± 0.02% FS/ °C
Response time	50 Milliseconds
Supply voltage	12 to 30 VDC
Power consumption	0.5 Watts
Relay contact rating	1A @ 30 VAC/VDC
Materials exposed to vacuum	304 stainless steel, 316 stainless steel
Housing material	Stainless steel, aluminum
Internal volume (with KF 16)	0.21 in ³ (3.4 cm ³)
Operating temperature	0 to 50 °C
Bakeout temperature (off)	85°C
Installation orientation	Any
CE Certification	EMC Directive 89/336/EEC
Vacuum connections	NW16 KF, 4 VCR [®] F, 8 VCR [®] F
Dimensions (with KF 16)	1.5" x 1.5" x 2.25" (38.1 x 38.1 x 57.2 mm)
Weight (with KF 16)	3.4 oz. (97 g)

Feature and Control Locations

902 Piezo

User access is through the 9-pin D-sub connector. The **ZERO** adjust button allows the user to manually perform a zero calibration. The user can perform zero calibration whenever the pressure is below 10 mTorr. See **Calibration Commands** in the **RS-485 Command Set** section for more information.

The figure below shows the top view of the 902.

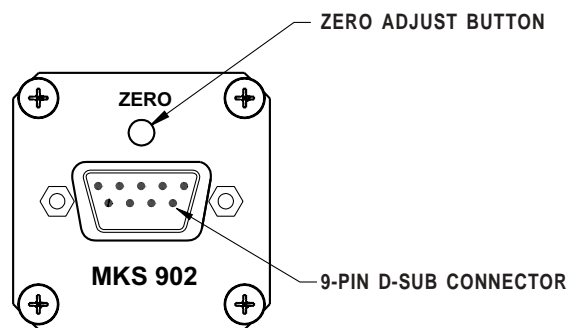

Optional Piezo Display Module

The 902 has an optional Piezo Display Module (PDM) to display pressure. The display reads the analog output voltage from the 902 and translates the data into pressure. To use the display module, the analog output format must be set to LINEAR10 (see **Analog Output Format – DAC** in the **Set Up Commands** section). The display has a resolution of 3½ digits, and shows three decades of pressure.

The figure below shows the optional PDM.

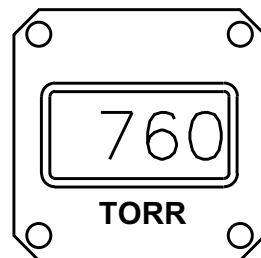

About the 902 Piezo

The 902 Piezo measures chamber pressures directly as a force or pressure is applied to the 902 Piezo's diaphragm. Once integrated into the vacuum system, the 902 Piezo's functions are computer-controlled, requiring little manual intervention by the user. This enables the system to monitor pressure as a procedure invisible to the user, and when the desired pressure is reached, trigger the next event in the system process.



This manual describes the installation and configuration tasks necessary to set up the 902 Piezo. After the device is set up, a software engineer at the user's installation would use the communications protocol described in this manual to create a software program (in, for example, Visual Basic, C, or C++) that will automatically control 902 Piezo operation.

For additional information on how the 902 Piezo works, see the appendix **How the 902 Piezo Works**.

Typical Applications for the 902 Piezo

- ◆ Atmospheric and sub-atmospheric pressure sensing.
- ◆ Measure fore and roughing pressures generated by mechanical vacuum pumps.
- ◆ Alarms to warn of abnormal pressures.
- ◆ Start or stop system processes with a relay set point.
- ◆ Monitor backfill and venting of gases.
- ◆ Control system pressure using digital communications or an analog output as an input to an automatic pressure controller.

Installing the 902 Piezo

Transducer Installation

Location

Locate the 902 where it can measure chamber or manifold pressure.

Orientation

The 902 can be mounted in any orientation without change of output or calibration.

Contamination

Locate and orient the Piezo where contamination is least likely. For example, if the 902 is mounted directly above a source of evaporation, the vapor could contaminate the sensor elements and cause the calibration to shift. Whenever possible, install the 902 with the vacuum port facing down to keep particulates or liquids from entering the device.

Vacuum Connection

The 902 is available with the following flanges:

- ◆ KF 16
- ◆ 4 VCR® F
- ◆ 8 VCR® F

The figure below shows the dimensions for each flange type.

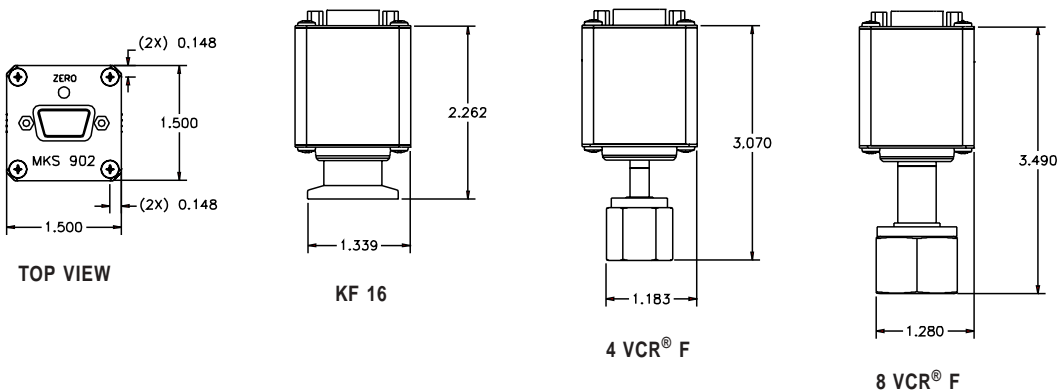

Electrical Connection

Use a cable with a female 9-pin D-sub connector with strain reliefs to ensure proper electrical connection and to reduce stress on the connectors.



Ensure a low impedance electrical connection between the 902 sensor body and the grounded vacuum system to shield the sensor from external electromagnetic sources.

Input/Output Wiring

The figure and the **902 Piezo Electrical Connections Table** on the following page identify the pins of the 902 connector and their functions; make a cable using this information. To comply with EN61326-1 immunity requirements, use a braided, shielded cable. Connect the braid to the metal hoods at both ends of the cable with the end for power supply connected to earth ground.

The power supply input is 12 to 30 VDC. The positive side of the power supply is connected to pin 3 and the negative side to pin 4 of the male D-sub connector.



Damage may occur to the circuitry if excessive voltage is applied, polarity reversed, or if a wrong connection is made.

If using analog output (described in the **Analog Output** section), the analog output voltages are pins 5 (+) and 8 (-). Connect them to a differential input voltmeter or an analog-to-digital (A/D) converter with a differential input in a system controller.



Do not connect the negative side of the analog output (pin 8) to the negative side of the power supply input (pin 4) or to any other ground. Doing so will cause half of the power current to flow through this wire. Measurement errors in the output voltage may be seen due to the voltage drop from this current. The longer the cable, the worse the error will be.



Do not connect the set point relay terminals to the analog output.

902 Piezo Electrical Connections Table

The digital communications connections are pins 7 and 9. RS-485 uses pin 7 for RS485(-) and pin 9 for RS485(+). RS-232 uses pin 7 for RS232 transmit (TXD) and pin 9 for RS232 receive (RXD).

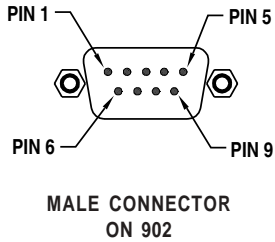

PIN	DESCRIPTION
1	RELAY N.O.
2	RELAY N.C.
3	POWER +
4	POWER -
5	ANALOG OUT +
6	RELAY COMMON
7	RS485 - / RS232 TXD
8	ANALOG OUT -
9	RS485 + / RS232 RXD

Relay Inductive Loads and Arc Suppression

If using the set point relay to switch inductive loads (e.g., solenoids, relays, transformers, etc.), the arcing of the relay contacts might interfere with 902 operation and reduce relay contact life. Therefore, an arc suppression network, shown schematically below, is recommended.

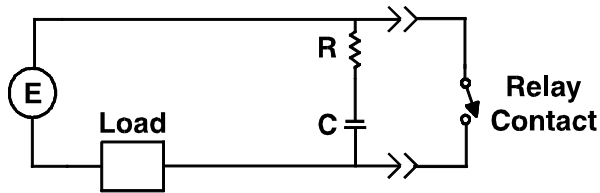

The values of the capacitance C and the resistance R can be calculated by the following equations:

$$C = I^2 / (1 \times 10^7)$$

$$R = E / I^a$$

where:

C is in farads

R is in ohms

I is DC or Ac_{peak} load current in amperes

E is DC or Ac_{peak} source voltage in volts

$$a = 1 + (50 / E)$$

Note that $R_{min} = 0.5 \Omega$ and $C_{min} = 1.0 \times 10^{-9} F$

Piezo Display Module Connection

The Piezo Display Module (PDM) attaches to the 902 through the D-sub connector. The PDM has a through connector to attach the combined PDM and 902 unit to the rest of the system. The following figure shows how to connect the PDM to the 902. Use the two slide lock posts supplied with the PDM kit.

1. Remove 2x Hex screws and 2x lock washers. Replace with 2x slide lock posts.

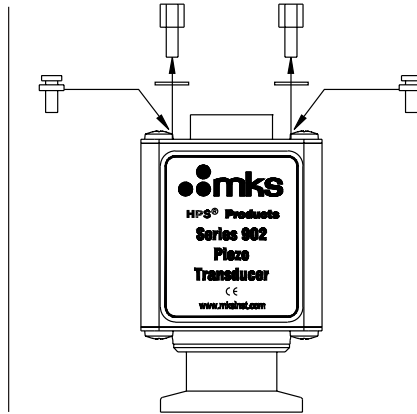

2. Ensure slide lock is in UNLOCK position.

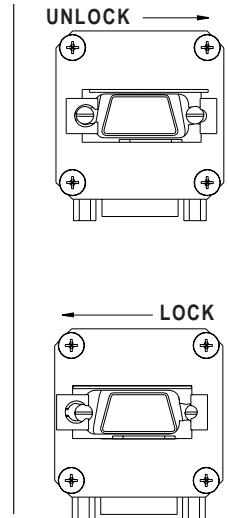

3. Connect PDM to 902. Move slide lock to LOCK position.

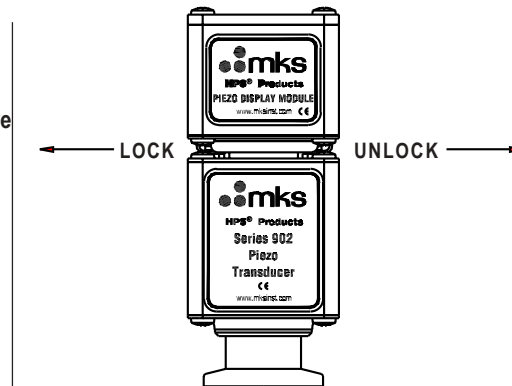

Front and back view of PDM display connected to 902.

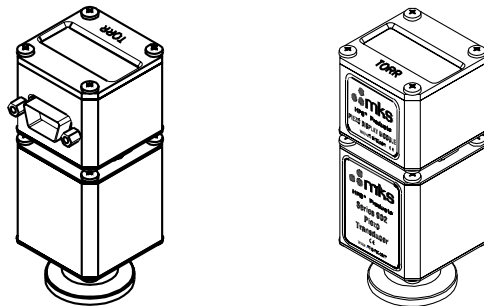

Operation

The 902 Piezo operation parameters are preset at the factory. The table below shows the factory default settings. Use the user interface and the commands described on the following pages to change parameter settings as necessary. The user interface to the 902 Piezo is through either RS-232 or RS-485 serial communications. RS-232 and RS-485 use the same commands to communicate with the 902; however, RS-485 allows communication with multiple transducers, whereas RS-232 allows communication with only a single transducer. The remainder of this manual refers to RS-485 only.

902 Piezo Factory Defaults Table

Setting	Default
Address	253
Baud Rate	9600
Pressure Units	Torr
Analog Output Format (DAC)	Linear 10
Set Point	500.0 Torr
Hysteresis	505.0 Torr
Set Point Direction	Below
Enable Set Point	Off
User Zero	Factory Zero calibration
User Span	Factory Span calibration

RS-485 Protocol

The 902 supports 2400, 4800, 9600, and 19200 baud rates (factory default: 9600). The data format is 8 data bits, no parity, and one stop bit.

Standard Addresses

Valid addresses are 1 to 253 (factory default: 253).

Universal Addresses

The 902 receives and responds to commands sent to address 254. For example, use 254 to communicate with a device if its address is unknown. The 902 receives and acts upon commands sent to address 255, but does not respond; use 255 to broadcast messages to multiple devices attached to the same system. For example, use 255 to change the analog output format for all devices.

Query and Command Syntax

Queries return current parameter settings; commands change the parameter setting according to the value the user types in the command syntax. Each query or command must begin with the attention character @ and end with the termination string ;FF.

Syntax required for a query is:

@<device address><query>?;FF.

Syntax required for a command is:

@<device address><command>!<parameter>;FF.

Examples:

Query current baud rate: @253BR?;FF

Change baud rate to 19200: @253BR!19200;FF

where:

@	<attention character>
253	<device address>
BR?	<query> (for query syntax)
BR!19200	<command>!<parameter> (for command syntax)
;FF	<terminator>

Response Syntax (ACK/NAK)

The ASCII characters 'ACK' or 'NAK' preface the query or command response string. The ACK sequence signifies the message was processed successfully. The NAK sequence indicates there was an error.

The response to a query or a successful command is:

@<device address>ACK<data>;FF

The response to a message with an error is:

@<device address>NAK<NAK code>;FF

Examples:

ACK response: @253ACK9600;FF (baud rate changed to 9600)

NAK response: @253NAK160;FF (command had an error—possibly a typo)

The following list provides descriptions of the NAK codes that may be returned.

Error	NAK Code
Invalid zero calibration parameter	5
Invalid span calibration parameter	6
Invalid zero calibration reading	8
Invalid span calibration reading	9
Unrecognized message	160
Invalid argument	169
Value out of range	172
Command/query character invalid (! or ?)	175
Invalid decimal number	176
Write to Flash EE failed	196
Read from Flash EE failed	197

RS-485 Command Set

The query and command formats shown in this section are examples; the values may vary for the user's installation.

Set Up Commands

Address – AD

The AD command returns or sets the 902 address. Note: If multiple devices are installed on the system, an address query using 254 (shown in the query example below) cannot determine the address of only one of the devices.

Values: 001 to 253 (default: 253)

Query: @254AD?;FF
Query Response: @254ACK001;FF
Command: @001AD!002;FF
Command Response: @002ACK002;FF

Analog Output Format – DAC

The DAC command returns or sets the format of the analog output from the Digital to Analog Converter. See the **Analog Output** section for information on the different linear and logarithmic analog outputs.

Values: LOG5, LOG10, LINEAR5, LINEAR10
(default: LINEAR10)

Query: @001DAC?;FF
Query Response: @001ACKLOG10;FF
Command: @001DAC!LINEAR10;FF
Command Response: @001ACKLINEAR10;FF

Baud Rate – BR

The BR command returns or sets the baud rate of the communications protocol. The 902 responds to this command at the present baud rate; however, the user will need to change the baud rate on the host to ensure future commands are sent at the same rate.

Values: 2400, 4800, 9600, 19200 (default: 9600)

Query: @001BR?;FF
Query Response: @001ACK9600;FF
Command: @001BR!19200;FF
Command Response: @001ACK19200;FF

Factory Default – FD

The FD command sets all 902 parameter values to the factory default settings shown in the **902 Piezo Factory Defaults Table** (page 18).

Note: The FD command overrides all parameter values the user sets; use with caution! The address and baud rate reset to 253 and 9600, respectively. The user must change the address and baud rate to these values on the host to communicate with the transducer after using the FD command.

Command: @001FD!;FF
Command Response: @001ACKFD;FF

Unit – U

The U command returns or sets the pressure unit to Torr, mBar, or Pascal. The units affect all pressure measurements, including set point values.

Values: TORR, MBAR, PASCAL (default: TORR)

Query: @001U?;FF
Query Response: @001ACKTORR;FF
Command: @001U!MBAR;FF
Command Response: @001ACKMBAR;FF

User Tag – UT

The UT command returns or sets the user tag label to assign for 902 identification.

Values: Up to 30 ASCII characters

Query: @001UT?;FF
Query Response: @001ACKCHAMBER1;FF
Command: @001UT!CHAMBER2;FF
Command Response: @001ACKCHAMBER2;FF

Status Commands

Device Type – DT

The DT command returns the transducer device type.

Query: @001DT?;FF
Query Response: @001ACK902;FF

Firmware Version – FV

The FV command returns the 902 firmware version.

Query: @001FV?;FF
Query Response: @001ACK1.00;FF

Hardware Version – HV

The HV command returns the 902 hardware version.

Query: @001HV?;FF
Query Response: @001ACKA;FF

Manufacturer – MF

The MF command returns the 902 manufacturer.

Query: @001MF?;FF
Query Response: @001ACKHPS;FF

Model – MD

The MD command returns the 902 model number.

Query: @001MD?;FF
Query Response: @001ACK902;FF

Pressure Reading – PR1

The PR1 command returns the measured pressure.

Query: @001PR1?;FF
Query Response: @001ACK760.3;FF

Serial Number – SN

The SN command returns the 902 serial number.

Query: @001SN?;FF
Query Response: @001ACK000012345;FF

Time On – TIM

The TIM command returns the number of hours the transducer has been on.

Query: @001TIM?;FF
Query Response: @001ACK1020;FF

Transducer Temperature – TEM

The TEM command returns the transducer's on-chip Microprocessor temperature in °C. The 902 temperature reading is nominally 5–10°C above ambient temperature.

Query: @001TEM?;FF
Query Response: @001ACK32.0;FF

Set Point Commands

Set Point Value – SP1

The SP1 command returns or sets the set point value. The set point value is the pressure either below or above which the set point relay will be energized (i.e., N.O. and common contacts will be closed). The direction of the set point (ABOVE or BELOW) is configured using the **Set Point Direction – SD1** command, below. The set point must be enabled for the SP1 command to function (see the **Enable Set Point – EN1** command, next page).

Values: Four-digit number (default: 500.0 Torr)

Query: @001SP1?;FF
Query Response: @001ACK100.0;FF
Command: @001SP1!760.0;FF
Command Response: @001ACK760.0;FF

Hysteresis Value – SH1

The SH1 command returns or sets the pressure value at which the set point relay will be de-energized (i.e., N.C. and common contacts will be opened). Depending on the set point direction, the SH1 value defaults to either 1% or 1 Torr (whichever is greater) below or above the set point value (see **Set Point Direction – SD1**, below and **Set Point Value – SP1**, above). If the hysteresis and set point are the same value, or nearly the same value, the relay may chatter when the system pressure is near the set point.

Values: Four-digit number (default: 505.0 Torr)

Query: @001SH1?;FF
Query Response: @001ACK767.6;FF
Command: @001SH1!764.0;FF
Command Response: @001ACK764.0;FF

Set Point Direction – SD1

The SD1 command returns or sets the direction of the set point. BELOW sets the relay when the pressure is *below* the set point value; ABOVE sets the relay when the pressure is *above* the set point value. If the SD1 value is BELOW, then the hysteresis value must be *above* the set point value (e.g., SP1: 100, SH1: 101). If the SD1 value is ABOVE, then the hysteresis value must be *below* the set point value (e.g., SP1: 100, SH1: 99). (See **Set Point Value – SP1** and **Hysteresis Value – SH1**, above.)

Values: BELOW, ABOVE (default: BELOW)

Query: @001SD1?;FF
Query Response: @001ACKBELOW;FF
Command: @001SD1!ABOVE;FF
Command: @001ACKABOVE;FF

Enable Set Point – EN1

The EN1 command returns enable status or enables the set point relay.

Values: OFF, ON (default: OFF)

Query: @001EN1?;FF
Query Response: @001ACKOFF;FF
Command: @001EN1!ON;FF
Command: @001ACKON;FF

Set Point Status – SS1

The SS1 command returns the status of the set point relay.

Values: SET, CLEAR

Query: @001SS1?;FF
Query Response: @001ACKCLEAR;FF

Calibration Commands

The 902 is adjusted at the factory using very accurate pressure references. The user may need to periodically readjust the zero and span calibrations on the transducer. Perform zero calibration only when the pressure is below 10 mTorr. Perform span calibration only with a very accurate pressure reference like the MKS 390A which has reading errors of less than 0.05%.

User Zero Calibration – ZER

The ZER command zeroes the 902 reading. Evacuate the transducer pressure to a measurement below 10 mTorr before performing zero calibration. Optionally, the user can press the **ZERO** button on the top of the 902 to perform zero calibration.

Command: @001ZER!;FF
Command Response: @001ACKZER;FF

User Span Calibration – SPN

The SPN command sets the span readout for the 902. Vent the transducer pressure to a measurement between 500–1000 before performing the span calibration.

Command: @001SPN!760.0;FF
Command Response: @001ACK760.0;FF

Analog Output

The 902 analog voltage signals are pins 5 (+) and 8 (-). Connect them to a differential input voltmeter or analog-to-digital converter (ADC). The standard 902 analog transducer provides an analog output of 0 to 10 VDC.

Users can select either linear or logarithmic analog output with the **Analog Output Format – DAC** command (**Set Up Commands** section). The user can also select linear and logarithmic outputs with a full scale output of 5 volts.



Do not connect the negative side of the analog output (pin 8) to the power supply return (pin 4) or to any other ground. The voltage drop from the supply current will produce errors in the analog output voltage. The longer the cable, the worse the error will be.

Linear versus Logarithmic Analog Output

Whether to choose linear or logarithmic analog output depends on the pressure measurement needs of the user. Each analog output type has its advantages. If using the optional Piezo display module, the display works only with Linear 10.

Linear Analog Output

The advantage of the default 10 VDC linear analog output is that it is easy to interpret, since the pressure reading (Torr) is equal to 100 times the voltage reading (e.g., 7.600 volts = 760.0 Torr).

The disadvantage of linear analog output is that the voltage reading is only 1 mV at 0.1 Torr. This means the user must use a 16-bit ADC to read the lowest decade of pressure.

Logarithmic Analog Output

The advantage of logarithmic analog output is that it has the same resolution in each decade of pressure. The 902 has four decades of pressure measurement. In a logarithmic analog output, each decade has 20% of the full scale. This allows the user to measure all four decades of pressure with a 12-bit ADC. If it is necessary to see when power is on at vacuum, then the logarithmic output is better (at vacuum, Logarithmic 10 reads 2.0 VDC and Logarithmic 5 reads 1.0 VDC, but both linear outputs read 0.0 VDC).

The disadvantage of logarithmic output is that the pressure is more difficult to interpret. The user will need to use a computer or calculator to read the pressure equation. The equations are shown later in this section with the Logarithmic 10 and Logarithmic 5 examples.

The following graphs show examples of the linear and logarithmic analog output. The **Pressure to Voltage Table**, following the analog output graphs, shows the relationship of linear and logarithmic analog output to pressure.

Linear 10

The graph below shows the correlation of linear analog output to pressure on a 0 to 10 volt scale. This is the output the user will see if the **Analog Output Format – DAC** value is **LINEAR10**. The linear output is 10 mV/Torr or $P(\text{Torr}) = V \times 100$.

902 Linear Analog Output (0 - 10 Volt Scale)

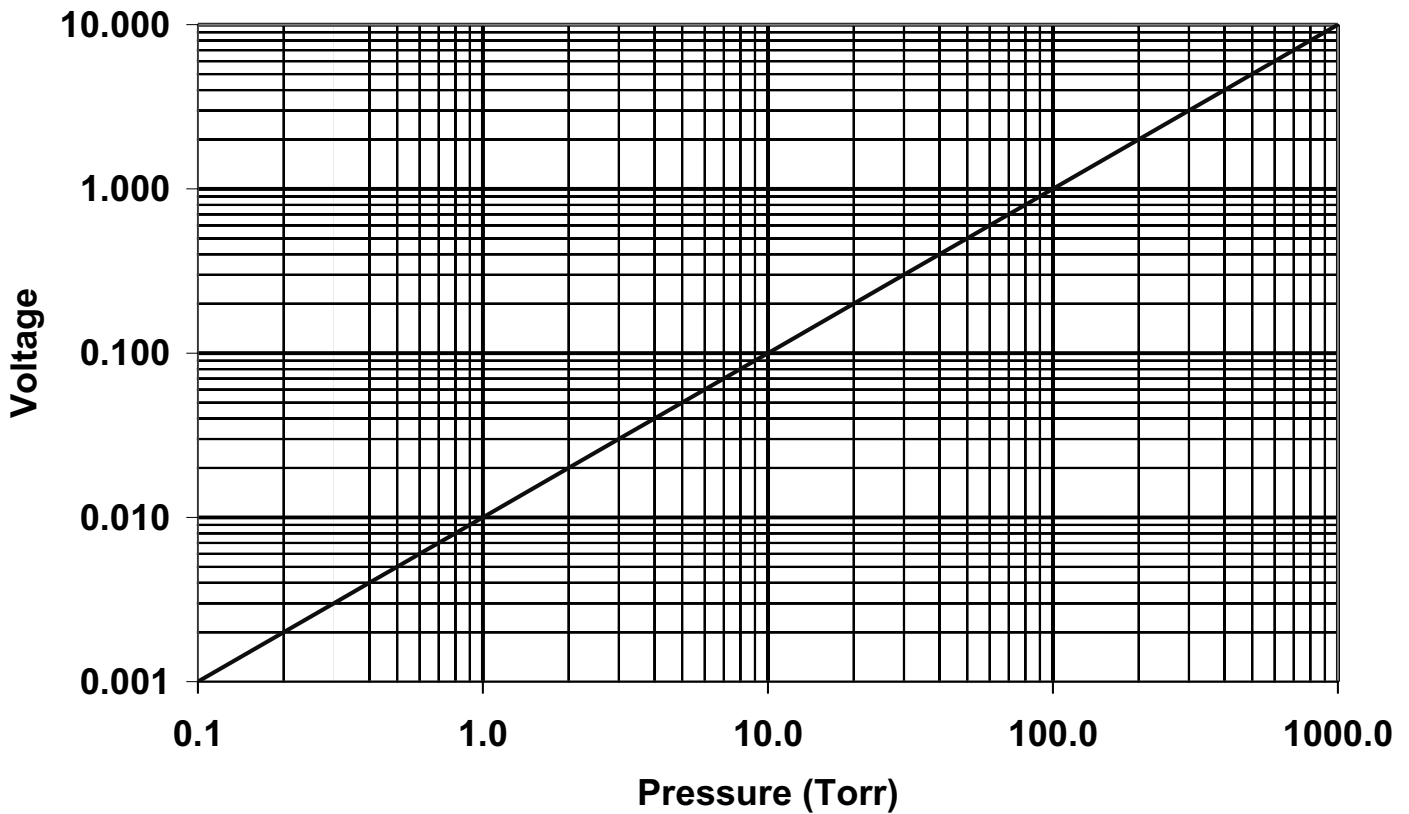

Linear 5

The graph below shows the correlation of linear analog output to pressure on a 0 to 5 volt scale. This is the output the user will see if the **Analog Output Format – DAC** value is **LINEAR5**. To receive analog output for LINEAR5, the converter must have a 5 volt scale. The linear output is 5 mV/Torr or $P(\text{Torr}) = V \times 200$.

902 Linear Analog Output (0 - 5 Volt Scale)

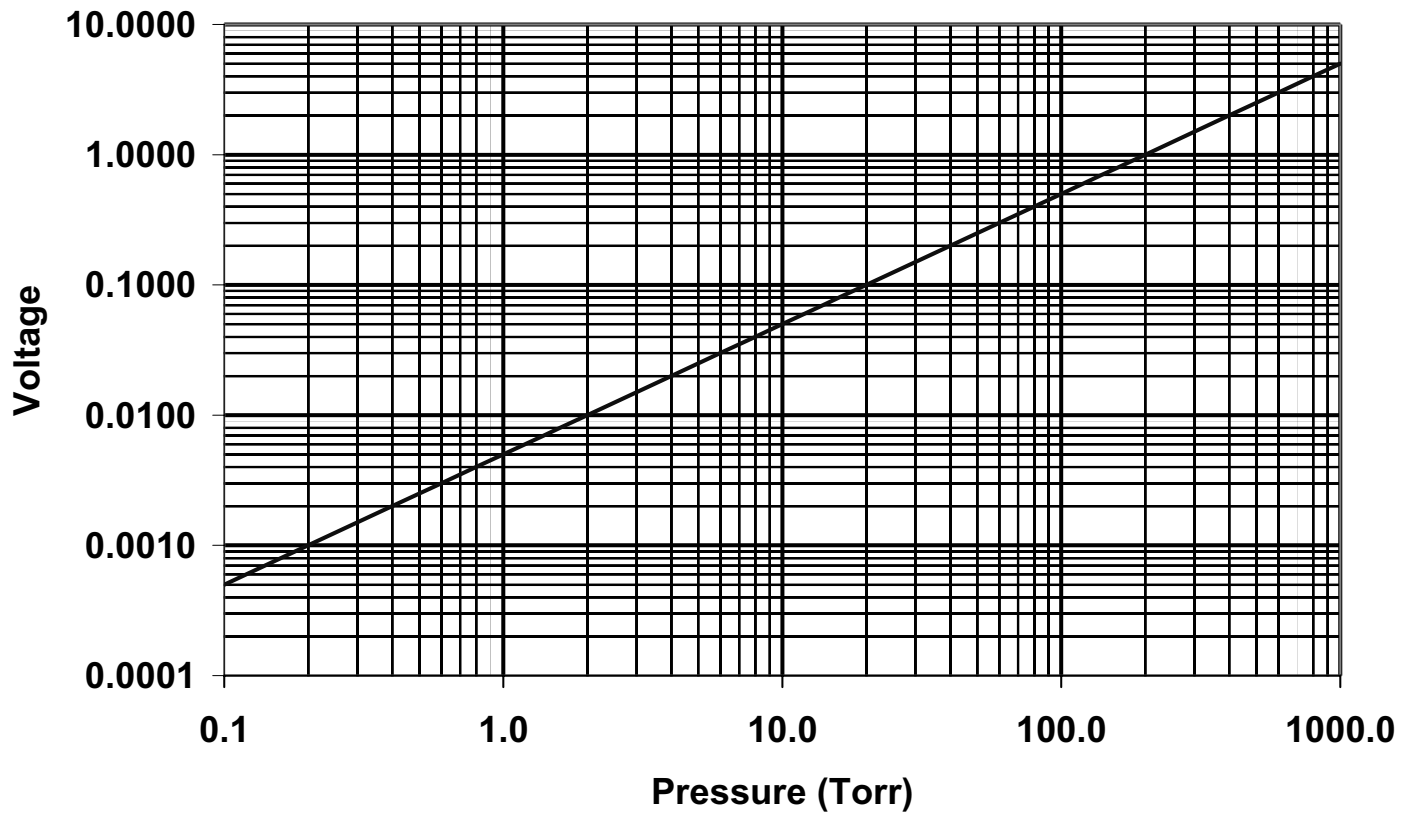

Logarithmic 10

The following graph shows the correlation of logarithmic analog output to pressure on a 2 to 10 volt scale. This is the output the user will see if the **Analog Output Format – DAC** value is **LOG10**. To receive analog output for LOG10, the converter must have a 10 volt scale. The logarithmic output is $P \text{ (Torr)} = 10^{(V/2-2)}$.

902 Logarithmic Analog Output (2 - 10 Volt Scale)

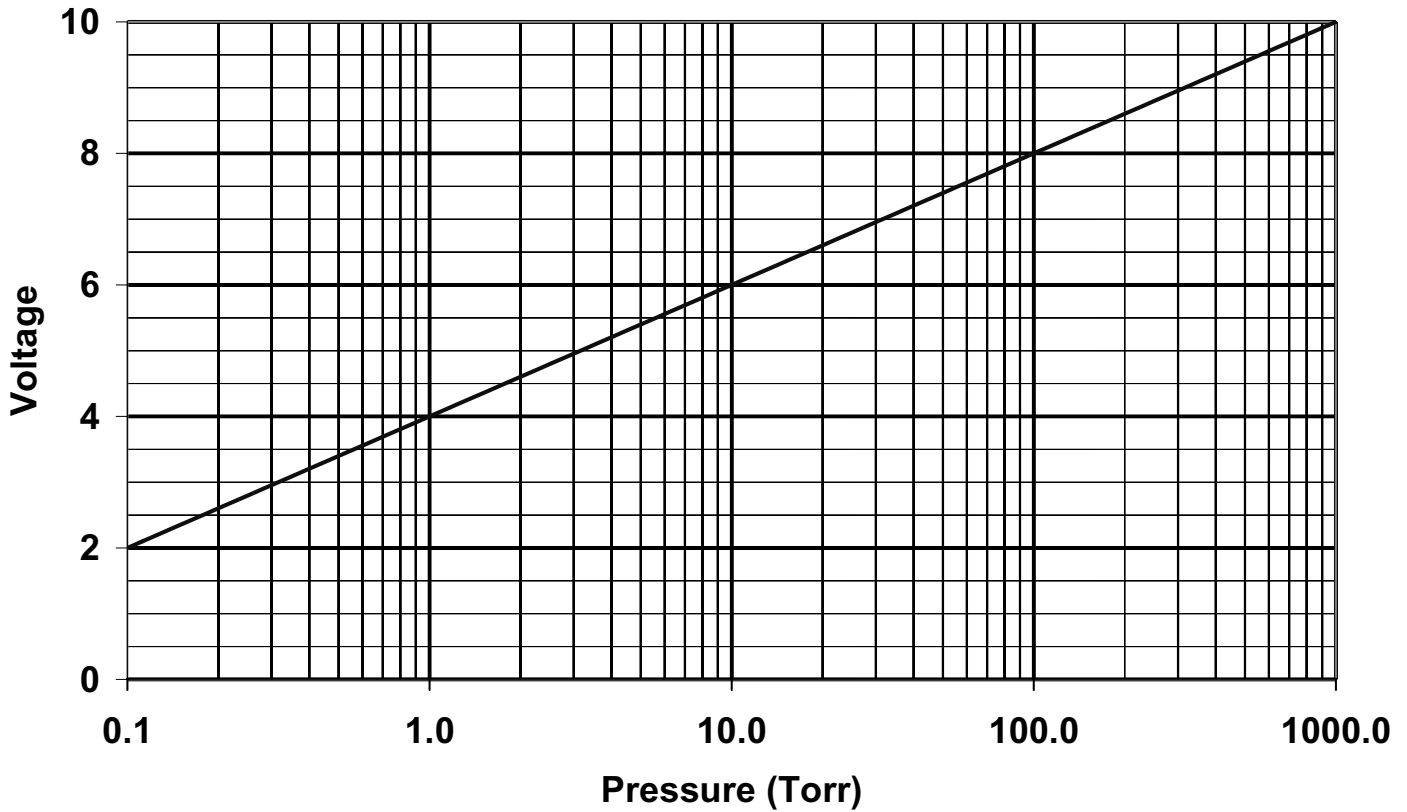

Logarithmic 5

The following graph shows the correlation of logarithmic analog output to pressure on a 1 to 5 volt scale. This is the output the user will see if the **Analog Output Format – DAC** value is **LOG5**. To receive analog output for LOG5, the converter must have a 5 volt scale. The logarithmic output is $P \text{ (Torr)} = 10^{(V-2)}$.

902 Logarithmic Analog Output (1 - 5 Volt Scale)

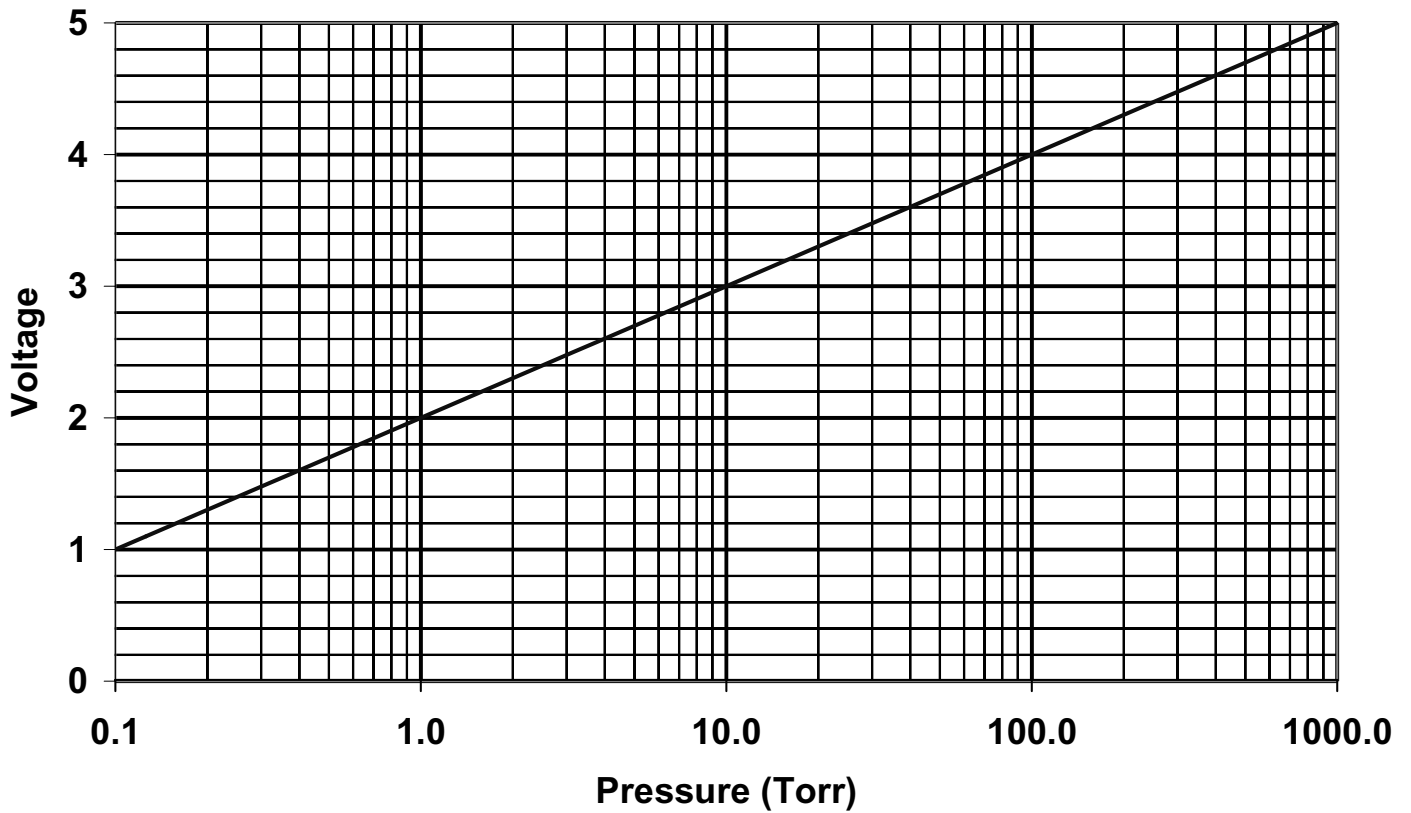

Pressure to Voltage Table

Pressure (Torr)	Linear10 (Volts)	Log10 (Volts)	Linear5 (Volts)	Log5 (Volts)
Power Off	0.0000	0.0000	0.0000	0.0000
0.0	0.0000	2.0000	0.0000	1.0000
0.1	0.0010	2.0000	0.0005	1.0000
0.2	0.0020	2.6021	0.0010	1.3010
0.3	0.0030	2.9542	0.0015	1.4771
0.4	0.0040	3.2041	0.0020	1.6021
0.5	0.0050	3.3979	0.0025	1.6990
0.6	0.0060	3.5563	0.0030	1.7782
0.7	0.0070	3.6902	0.0035	1.8451
0.8	0.0080	3.8062	0.0040	1.9031
0.9	0.0090	3.9085	0.0045	1.9542
1.0	0.0100	4.0000	0.0050	2.0000
2.0	0.0200	4.6021	0.0100	2.3010
3.0	0.0300	4.9542	0.0150	2.4771
4.0	0.0400	5.2041	0.0200	2.6021
5.0	0.0500	5.3979	0.0250	2.6990
6.0	0.0600	5.5563	0.0300	2.7782
7.0	0.0700	5.6902	0.0350	2.8451
8.0	0.0800	5.8062	0.0400	2.9031
9.0	0.0900	5.9085	0.0450	2.9542
10.0	0.1000	6.0000	0.0500	3.0000
20.0	0.2000	6.6021	0.1000	3.3010
30.0	0.3000	6.9542	0.1500	3.4771
40.0	0.4000	7.2041	0.2000	3.6021
50.0	0.5000	7.3979	0.2500	3.6990
60.0	0.6000	7.5563	0.3000	3.7782
70.0	0.7000	7.6902	0.3500	3.8451
80.0	0.8000	7.8062	0.4000	3.9031
90.0	0.9000	7.9085	0.4500	3.9542
100.0	1.0000	8.0000	0.5000	4.0000
200.0	2.0000	8.6021	1.0000	4.3010
300.0	3.0000	8.9542	1.5000	4.4771
400.0	4.0000	9.2041	2.0000	4.6021
500.0	5.0000	9.3979	2.5000	4.6990
600.0	6.0000	9.5563	3.0000	4.7782
700.0	7.0000	9.6902	3.5000	4.8451
800.0	8.0000	9.8062	4.0000	4.9031
900.0	9.0000	9.9085	4.5000	4.9542
1000.0	10.0000	10.0000	5.0000	5.0000

Maintenance and Troubleshooting

Maintenance and Troubleshooting Table

Symptom	Possible Cause/Remedy
No response to RS-485 commands	<ul style="list-style-type: none">- Attention character (@) missing- Address incorrect- Termination characters (;FF) missing- Baud rate incorrect- Electrical connections missing or incorrect <p>Note: If baud rate and electrical connections are correct, then @254;FF should give the response @253NAK160;FF (the address may be different from 253).</p>
Vacuum pressure reading too high/too low	Adjust zero calibration using the User Zero Calibration – ZER command, or press the ZERO button on top of the transducer.
Atmospheric pressure too high/too low	Adjust span calibration using the User Span Calibration – SPN command.
Set point does not trip	<ul style="list-style-type: none">- Set point not enabled- Set point hysteresis value not set to proper value- Set point direction is different from what the user expects- Connector miswired
No analog output voltage	<ul style="list-style-type: none">- Power supply turned off- Electrical connections missing or incorrect- Incorrect analog output format. Verify or change the analog output format with the Analog Output Format – DAC command.

Accessories and Part Replacement

<u>Description</u>	<u>Part Number</u>
902, display module, 1000 Torr, red LED	902001
902, display module, 1000 Torr, LCD	902002
Cable, 9-pin D-sub, 10 feet	103170006SH
Cable 9-pin D-sub, 25 feet	103170007SH
Cable 9-pin D-sub, 50 feet	103170008SH
Operation and Maintenance Manual	100011739

Warranty

Extent of the Warranty

MKS Instruments, Inc. (MKS), HPS® Products, warrants the HPS® Products Series 902 Piezo Transducer and its accessories to be free from defects in materials and workmanship for one (1) year from the date of shipment by MKS or authorized representative to the original purchaser (PURCHASER). Any product or parts of the product repaired or replaced by MKS under this warranty are warranted only for the remaining unexpired part of its one (1) year original warranty period. After expiration of the applicable warranty period, the PURCHASER shall be charged MKS' current prices for parts and labor, plus any transportation for any repairs or replacement.

ALL EXPRESS AND IMPLIED WARRANTIES, INCLUDING THE IMPLIED WARRANTIES OF MERCHANTABILITY AND FITNESS FOR A PARTICULAR PURPOSE, ARE LIMITED TO THE WARRANTY PERIOD. NO WARRANTIES, EXPRESS OR IMPLIED, WILL APPLY AFTER THIS PERIOD.

Warranty Service

The obligations of MKS under this warranty shall be at its option: (1) to repair, replace, or adjust the product so that it meets applicable product specifications published by MKS or (2) to refund the purchase price.

What is Not Covered

The product is subject to above terms only if located in the country of the seller from whom the product was purchased. The above warranties do not apply to:

- I. Damages or malfunctions due to failure to provide reasonable and necessary maintenance in accordance with MKS operating instructions.
- II. Damages or malfunctions due to chemical or electrolytic influences or use of the product in working environments outside the specification.
- III. Fuses and all expendable items which by their nature or limited lifetime may not function for a year. If such items fail to give reasonable service for a reasonable period of time within the warranty period of the product, they will, at the option of MKS, be repaired or replaced.
- IV. Defects or damages caused by modifications and repairs effected by the original PURCHASER or third parties not authorized in the manual.

Condition of Returned Products

MKS will not accept for repair, replacement, or credit any product which is asserted to be defective by the PURCHASER, or any product for which paid or unpaid service is desired, if the product is contaminated with potentially corrosive, reactive, harmful, or radioactive materials, gases, or chemicals. When products are used with toxic chemicals, or in an atmosphere that is dangerous to the health of humans, or is environmentally unsafe, it is the responsibility of the PURCHASER to have the product cleaned by an independent agency skilled and approved in the handling and cleaning of contaminated materials before the product will be accepted by MKS for repair and/or replacement. In the course of implementing this policy, MKS Customer Service Personnel may inquire of the PURCHASER whether the product has been contaminated with or exposed to potentially corrosive, reactive, harmful, or radioactive materials, gases, or chemicals when the PURCHASER requests a return authorization. Notwithstanding such inquiries, it is the responsibility of the PURCHASER to ensure that no products are returned to MKS which have been contaminated in the aforementioned manner.

Other Rights and Remedies

- I. These remedies are exclusive. HPS® SHALL NOT BE LIABLE FOR CONSEQUENTIAL DAMAGES, FOR ANTICIPATED OR LOST PROFITS, INCIDENTAL DAMAGES OR LOSS OF TIME, OR OTHER LOSSES INCURRED BY THE PURCHASER OR BY ANY THIRD PARTY IN CONNECTION WITH THE PRODUCT COVERED BY THIS WARRANTY, OR OTHERWISE. Some states do not allow exclusion or limitation of incidental or consequential damage or do not allow the limitation on how long an implied warranty lasts. If such laws apply, the limitations or exclusions expressed herein may not apply to PURCHASER.
- II. Unless otherwise explicitly agreed in writing, it is understood that these are the only written warranties given by HPS®. Any statement made by any persons, including representatives of MKS, which are inconsistent or in conflict with the terms of the warranty shall not be binding on MKS unless reduced to writing and approved by an authorized officer of MKS.
- III. This warranty gives PURCHASER specific legal rights, and PURCHASER may also have other rights which vary from state to state.
- IV. For MKS products sold outside of the U. S., contact your MKS representative for warranty information and service.

Warranty Performance

To obtain warranty satisfaction, contact the following: MKS Instruments, Inc., HPS® Products, 5330 Sterling Drive, Boulder, CO 80301, USA, at phone number 1-303-449-9861. You may be required to present proof of original purchase.

Appendix: How the 902 Piezo Transducer Works

The 902 sensor consists of a bridge of piezoresistive elements on a diaphragm, which change their resistance proportional to the pressure applied to the sensor. The resistance change in a monocrystalline semiconductor (piezoelectric effect) is substantially higher than that in a standard strain gauge. Resistance in a doped semiconductor is changed by a compression or stretching of the crystal grid that can be produced by an extremely small mechanical deformation. The advantages of piezoresistive sensors are very high sensitivity, very good linearity, and virtually no creep or hysteresis. A disadvantage with piezo sensors can be their nonlinearity with temperature. The 902 has electronic circuitry that provides temperature compensation to correct these variations.

The 902 sensor measures pressure directly and is gas-type independent. The 902 uses a diaphragm referenced to an evacuated vacuum pressure. The 902 sensor piezoresistive diaphragm is linked to a stainless steel diaphragm. The 316 stainless steel diaphragm is the only part of the sensor that is exposed to vacuum.

The figure below shows an interior view of the 902 and how it works.

