

RS-232 (DB-9)  
 AUX PORT (DB-15)  
 SERVICE PORT (USB)

PURGE GAS PORT (1/2" SWAGELOK)  
 CHAMBER VENT (KF-16)  
 PUMP EXHAUST (KF-25)

SYSTEM POWER BULKHEAD

REMOVABLE  
 PANELS

BUTTON PANEL  
 CONTROL

VACUUM  
 GAUGE  
 CONTROLLER

HALO  
 VIEWING  
 WINDOW

POWER  
 BREAKER

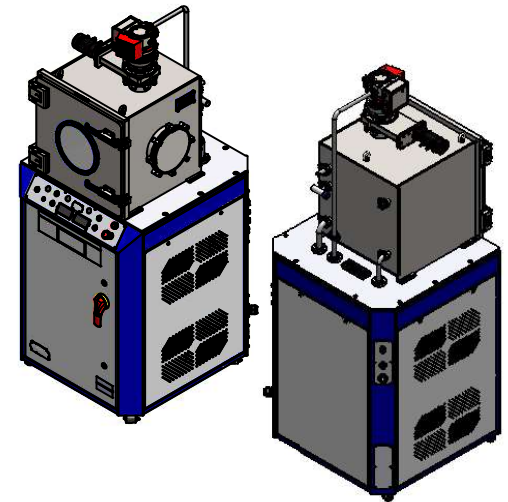
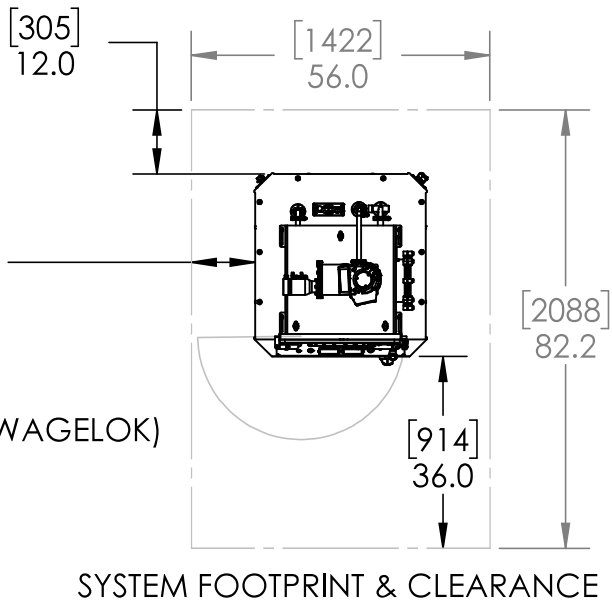

ISO-200  
 CONFIGURABLE  
 FEEDTHROUGH

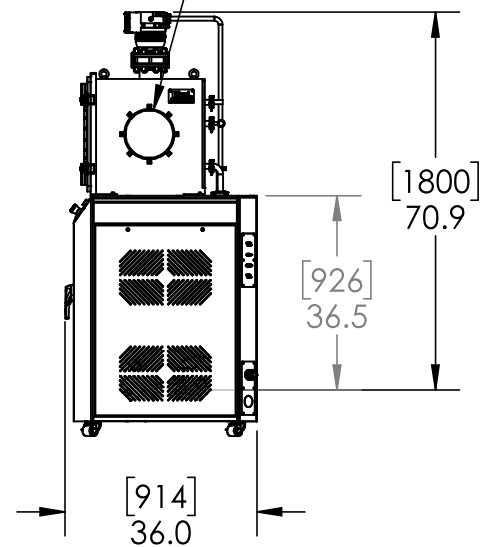

1. APPROXIMATE SYSTEM WEIGHT 800 LBS
2. CHAMBER INTERNAL DIMENSIONS 20" x 20" x 20"
3. MAINTAIN RECOMMENDED SIDE CLEARANCE FOR PROPER VENTILATION
4. INSTALL WITH CASTERS OR FIXED LEVELING FEET (BOTH INCLUDED)

## Ideal Vacuum Products

ExploraVac Standard  
 Configuration: High Vacuum

SIZE	Part No: P1012092	SCALE: 1:36
<b>A</b>		SHEET 1 OF 1

5

4

3

2

1