

TELEDYNE HASTINGS INSTRUMENTS



INSTRUCTION MANUAL

MODEL 2002 VACUUM GAUGE



Manual Print History

The print history shown below lists the printing dates of all revisions and addenda created for this manual. The revision level letter increases alphabetically as the manual undergoes subsequent updates. Addenda, which are released between revisions, contain important change information that the user should incorporate immediately into the manual. Addenda are numbered sequentially. When a new revision is created, all addenda associated with the previous revision of the manual are incorporated into the new revision of the manual. Each new revision includes a revised copy of this print history page.

Revision D (Document Number 149-102002)	October 2002
Revision E (Document Number 149-062004)	June 2004
Revision F (Document Number 149-082005	August 2005
Revision G (Document Number 149-102005)	October 2005
Revision H (Document Number 149-082008)	August 2008
Revision J (Document Number 149-122009)	December 2009
Revision K (Document Number 149-082010)	August 2010
Revision L (Document Number 149-012011)	January 2011
Revision M (Document Number 149-072011)	July 2011



Visit www.teledyne-hi.com for WEEE disposal guidance.



CAUTION

Refer to accompanying documents



CAUTION

If Equipment is not used in the manner specified
By this manual, protection provided
By the equipment man be impaired.

Hastings Instruments reserves the right to change or modify the design of its equipment without any obligation to provide notification of change or intent to change.

Table of Contents

1. GENERAL INFORMATION.....	4
1.1. FEATURES	4
1.2. MODEL 2002 SENSORS.....	4
1.3. MODEL 2002 CONTROL UNIT	4
1.4. SPECIFICATIONS	5
2. INSTALLATION.....	6
2.1. RECEIVING INSPECTION	6
2.2. QUICK START.....	6
2.3. TRANSDUCER INSTALLATION.....	6
2.4. CONTROL UNIT INSTALLATION.....	7
2.5. INITIAL OPERATION	7
3. FRONT PANEL OPERATION.....	8
3.1. OVERALL FUNCTIONAL DESCRIPTION.....	8
3.2. RUN MODE	9
3.3. HIGH AND LOW SET POINT MODES.....	10
3.4. CAL MODE.....	10
3.5. GAS MODE.....	12
3.6. UNITS MODE.....	13
4. REAR PANEL DESCRIPTION.....	14
4.1. REMOTE ZERO INPUT	14
4.2. ANALOG OUTPUT.....	14
4.3. TTL OUTPUTS.....	16
4.4. POWER ENTRY MODULE	16
5. THEORY OF OPERATION	18
5.1. PIEZORESISTIVE SENSOR.....	18
5.2. PIRANI SENSOR	20
5.3. DUAL SENSOR OPERATION	22
6. COMMUNICATIONS OPTION BOARD	23
6.1. RS-232-E INTERFACE SPECIFICATIONS.....	23
6.2. INTERFACE CONNECTOR PIN ASSIGNMENTS FOR RS-232	24
6.3. OPERATION OF THE SERIAL INTERFACE	24
7. RELAY INTERFACE OPTION BOARD.....	28
7.1. RELAY BOARD SPECIFICATIONS	28
7.2. RELAY CONNECTOR PIN ASSIGNMENT	28
8. 4-20 MA INTERFACE OPTION BOARD.....	29
8.1. 4-20 MA INTERFERENCE CONNECTOR PIN ASSIGNMENTS.....	29
8.2. OPERATION	30
9. 0-10V INTERFACE OPTION BOARD.....	31
10. TROUBLESHOOTING GUIDE.....	33
11. WARRANTY	34
11.1. WARRANTY REPAIR POLICY	34
11.2. NON-WARRANTY REPAIR POLICY	34
12. DIAGRAMS AND DRAWINGS.....	35

1. General Information

The Model 2002 is a wide range vacuum measuring instrument consisting of a digital microprocessor-based display unit, a miniature, rugged, thin film based sensing element that measures from below 1×10^{-4} up to 100 Torr, a piezoresistive sensor that measures from 1 to 1000 Torr, EEPROM (Electrically Erasable/Programmable Read Only Memory), and an interconnecting cable. Together, these components provide accurate vacuum measurement over 7 decades of vacuum from 1×10^{-4} to 1000 Torr. This instrument is a new design approach based on over 50 years of experience by Hastings Instruments with well-known and widely used thermal conduction vacuum measurement techniques. The Model 2002 is designed for quick, easy installation and will provide the user with long lasting, trouble free, accurate vacuum measurement.

1.1. Features

- Wide dynamic range: 1×10^{-4} to 1000 Torr
- Compact rugged design
- Attitude insensitive
- Fast dynamic response
- Withstands 150 psig positive pressure
- Linear per decade
- Bakeable to 2500C
- TTL output process control
- Interchangeable transducer
- Corrosion resistant

1.2. Model 2002 Sensors

The Model 2002 transducer is comprised of an ion implanted piezoresistive, direct force sensor and a thin film Pirani type sensor. The Pirani sensing element is a Pt thin film serpentine element (see Figure 5.3a) deposited on a 1 micron thick Si₃N₄ membrane. The membrane is peripherally supported by a Si box shaped die and is covered by a thick Si lid parallel to the membrane and open on two ends (see Figure 5.3b). The piezoresistive unit is an ion implanted Wheatstone bridge in a 50 micron thick Si membrane peripherally supported by a Si box shaped die which has been anodically bonded to a Pyrex substrate.

The dual sensor assembly is encased in a corrosion resistant 316 stainless steel tube shell. The durable tube design withstands high pressure (150 psig/10.2 bar) and high pressure surges. Since the Pirani sensor is miniaturized and employs a Pt thin film on a Si₃N₄ membrane (instead of a conventional long fragile wire), the transducer can withstand high levels of mechanical shock.

The Model 2002 is designed for fast response. The micro machined sensing elements have a very small mass and operate in a constant temperature (Pirani) and a constant current (piezo) feedback mode. This makes response time very fast as compared to other commercially available sensors which have to change the temperature of a significant mass to reflect pressure changes and have a large internal volume which must equalize in pressure with the system before the sensor can reach its final value. The transducer's small internal volume (<1.5cc) permits rapid pneumatic response to system pressure changes. Further, the small geometry of the transducer prevents a thermal convection current which allows the sensor to be mounted in any orientation without calibration shifts.

1.3. Model 2002 Control Unit

The Model 2002 control unit consists of the power supply, Pirani resistance bridge control, signal processing and display circuitry. The user interface consists of a flat panel display with smooth operating tactile switches and large green LED digits (0.56"/14.2mm). The pressure is displayed in scientific format using a 3 digit mantissa and a 1 digit (plus the sign) exponent. The pressure can be displayed in Torr, mbar or Pascal. The instrument comes standard with 2 alarm setpoints that have TTL level digital outputs. An optional dual relay board can be internally mounted to trip on the alarm setpoints to turn on/off various equipment such as pumps, valves, heaters, bake out ovens and safety equipment. An optional 4-20 mA or 0-10V analog output

board is also available. The Model 2002 instrument accepts an external TTL level "Remote Zero" to zero the instrument when another instrument (e.g. an ion gauge) indicates that the pressure is less than 1×10^{-5} Torr. The standard analog output is linear per decade directly corresponding to the control unit's display. The Model 2002 comes calibrated for nitrogen. Conversion factors for other gases are selectable by the user (see section 3.5). This direct readout display allows for flexibility in user system configurations which operate with various gases.

An optional serial interface board can be installed to provide RS232 or RS485 support. The Model 2002 control unit fits a standard DIN 43700 insert (1/4 DIN) and mounts into a 3.62 in. (92 mm) square hole. The case is constructed of NORYL rated UL-94-V1 (self-extinguishing plastic) and is equipped with mounting brackets that are adjustable up to 3/16" (4.8mm).

1.4. Specifications

Measuring range	1×10^{-4} to 10^{+3} Torr
.....	1.3×10^{-4} to $1.3 \times 10^{+3}$ mbar
Accuracy (N ₂ , T=230C)	+ 20% of reading (5×10^{-4} to $5 \times 10^{+1}$ Torr)
.....	+ 1.5% of reading ($5 \times 10^{+1}$ to $1 \times 10^{+3}$ Torr)
Ambient temperature operating range	0 ⁰ to 50 ⁰ C
Bakeout temperature (with transducer electronics removed)	250 ⁰ C
Analog output.....	1.0-4.5 Volts (0.5 VDC linear per decade)
Process control	2 TTL outputs (1 TTL auto zero input)
Digital readout.....	four green LED - resolution is three digit (plus exponent)
Equipment operating range	120/240 V~, 0.25A, 50/60 Hz
.....	A 6 ft., 3-wire power cord is provided with each unit.
Fuse.....	250 V, 1/4 A.
Transducer mounting.....	Any position without recalibration.
Transducer internal volume	<1.5cc
Wetted material	Au, Si ₃ N ₄ , Si, Pt, Pyrex™,
.....	Kovar™ and 316 SS
Stability with voltage	Variation in reading undetectable
.....	as power fluctuates within power specification.
Weight (display, cable, and sensor).....	Net: 2.5 lbs., Shipping: 3.4 lbs.
Transducer response time	typically, less than 150 msec for a step
.....	change from 10^{-3} Torr to 10^{+3} Torr.
Positive pressure.....	150 psig, Recalibration may be required
.....	if unit is exposed to pressures greatly exceeding measuring range.

2. Installation

This section is designed to assist in getting a new pressure gauge into operation as quickly and easily as possible. Please read the following instructions thoroughly before installing the instrument.

2.1. Receiving Inspection

Carefully unpack the Hastings Model 2002 Instrument (part # HPM-2002), transducer (part #HPM-2002s) and cable (part # CB 2002). Inspect all items for any obvious signs of damage due to shipment. Immediately advise the carrier who delivered the shipment if any damage is suspected.

Compare each component shipped against the packing list. Ensure that all parts are present (i.e. transducer, power supply, cables, etc.). In addition to the components listed on the packing list, the shipment includes: AC power cord, panel mounting hardware, 9-pin female D connector. Optional equipment or accessories will be listed separately on the packing list.

2.2. Quick Start

Follow this procedure to get your new Model 2000 vacuum gauge up and running.

1. Remove sensor from protective packaging.
2. Transducer tube may be installed in any orientation. However if condensation is likely to occur, then the port should be orientated downward.
3. When installing 1/8" NPT style transducer tube, use the 7/16" wrench flats on the tube stem.
4. Connect transducer cable (orange) to controller.
5. Connect other end of transducer cable to transducer. A finger tight connection is adequate for proper operation.
6. If you have computer interface or process control options, these cables can now be attached.
7. I/O port diagram is given in the manual.
8. Connect the AC power cord. The Model 2002 automatically adjusts for 120/240 VAC 50/60 Hz.
9. Turn on power switch. Gauge is now reading pressure in units of "Torr" (default).
10. For best accuracy, the gauge should now be zeroed. Pump the vacuum system down to low 10-6 Torr (if possible). Ideally the gauge should be operated in this condition for one hour.
11. Place the Model 2002 in the "CAL" mode by using the mode switch. Press the up and down arrows simultaneously ("CAL" light is now flashing).
12. Press the "ZERO" switch once and return to the "RUN" mode using the mode switch.

The gauge is now ready for normal operation and the display is a true indication of the system pressure (P < 8 Torr is N₂ equivalent).

2.3. Transducer Installation

The transducer may be installed in any orientation. Although the transducer is rugged and will perform well in many harsh environments, the tube should be installed in a clean and careful manner. The tube is configured with the vacuum fitting requested. If your vacuum environment is highly contaminated or has unique fitting requirements, a Hastings filter or special adapter may be needed. Please contact the Hastings Instruments Sales Department for assistance in your system configuration.

2.4. Control Unit Installation

- Environment:
- Indoor use
- Altitude up to 2000 meters
- Operating temperature range from 50 to 400C
- Maximum relative humidity: 80% for temperatures up to 310C decreasing linearly to 50% relative humidity at 400C
- Installation category II

Panel Mount Instructions:

The control unit can be panel mounted. See detail on page 43. The dimensions of the hole on the panel are 3.62" x 3.62"(92.8mm x 92.8 mm). Slide the neoprene gasket that was shipped with the control unit onto the case from the back. Slide the controller through the panel cutout. Hold the hardware against the side and tighten the two screws.

Transducer Cable Attachment:

The threaded connector attaches to the transducer. A finger tight connection is adequate for proper operation. The 9-pin male "D" connector attaches to the back panel (See Figure 4.2). The transducer cable connects to the left hand connector when looking at the back.

I/O Cable Attachment:

The mating male plug to the I/O connector is supplied with the unit. An I/O cable can be wired with the 9-pin female "D" connector to use the analog output, digital alarms or the remote zero functions. The connector will accept 20 gauge or smaller wire. The pinout is shown in Figure 4.2 (back panel figure). A detailed description of these pins is given in Section 4.

2.5. Initial Operation

Upon applying power to the control unit a pressure measurement will be given in Torr for nitrogen. However, it is recommended that the user follow the instructions for zeroing and adjusting the output at atmospheric pressure in Section 3.4 ("Cal Mode").

3. Front Panel Operation

3.1. Overall Functional Description

The front panel of the control unit is shown in Figure 3.1. The four circular blue buttons are used for the selection of display readout and the input of data. The green data field displays the data as determined by mode selection. The MODE switch toggles the control unit in a clockwise fashion among the six modes of operation:

- RUN** Normal operation, pressure is displayed in scientific notation. The analog to digital converter speed can be adjusted and the factory calibration can also be restored in this mode. See Section 3.2 for further information.
- HIGH** High set point is displayed in scientific notation, above this pressure the HIGH TTL output will be +5V.
- LOW** Low set point is displayed in scientific notation, below this pressure the LOW TTL output will be +5V.
- CAL** Pressure is displayed and can be adjusted.
- GAS** Gas number is displayed and selection may be changed.
- UNITS** Units used to display pressure are selected.

In the **RUN**, **HIGH**, and **LOW** modes, it is possible to see the display indicate that the data is out of range. Over range is indicated by $X.XX \times 10^-$. Under range is indicated by $0.0 \times 10^-$. A measured pressure below 1×10^{-4} Torr is indicated by $0.0 \times 10^+$. In the case of an unconnected or faulty sensor(s), it is possible to see “X”, “XX” OR “XX” See trouble shooting section (section 8) for more detail.

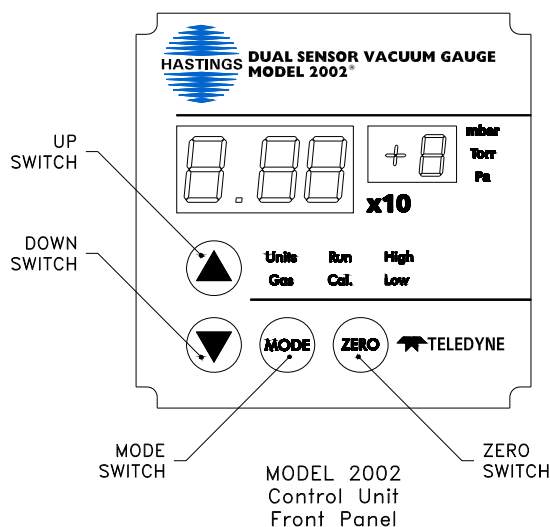

Model 2002
Control Unit
Front Panel

Fig 3.1

All six modes of the Model 2002 have features which can be accessed and modified after bypassing the front panel interlock. The interlock is in place to prevent the accidental corruption of the instrument's configuration and calibration. The interlock is bypassed using the following steps:

1. Place the instrument in one of the six modes.
2. Simultaneously press the up and down switches.

The mode light will now flash indicating that the interlock has been bypassed.

Scientific Notation

The Model 2002 measures pressure that spans more than seven decades. In order to easily display these readings, Hastings Instruments has employed scientific notation. In scientific notation, the mantissa (the fixed point part) is multiplied by some power of 10 (given by the exponent).

Powers of 10

$10^3 = 1000$	$10^{-1} = 0.1$
$10^2 = 100$	$10^{-2} = 0.01$
$10^1 = 10$	$10^{-3} = 0.001$
$10^0 = 1$	$10^{-4} = 0.0001$

As an example: $7.60 \times 10^{+2}$ Torr

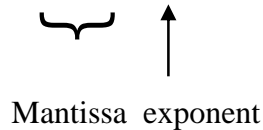

"7.60 multiplied by 100" = 760 Torr which is one atmosphere of pressure.

3.2. RUN Mode

Normal Operation

The Model 2002 will automatically enter RUN mode upon start-up. This is the mode for normal operation and the mode in which the instrument will typically spend most of its time. In the run mode, the Model 2002 unit will continuously monitor the pressure and update the alarm conditions at the speed of the A/D converter and will update the display about four times per second.

A/D Speed Adjust

The Model 2002 utilizes a 24 bit sigma-delta analog to digital converter. This type of converter averages the input over time to reject interference. Longer averaging times result in more accurate readings. Increasing the A/D speed will respond to sudden pressure changes faster.

While in the RUN mode, the user can adjust the A/D speed of operation. At start-up, the instrument will be operating with an A/D frequency of about 60 Hz. The speed can be adjusted one step faster or slower. Each step will increase or decrease the A/D frequency by a factor of two.

To adjust the A/D speed, press the MODE switch until the RUN light is illuminated. Then simultaneously press the up and down switches. The RUN light will now flash indicating that the interlock has been bypassed and the A/D speed can be adjusted. Push the up switch to speed up the A/D converter one step and decrease the response time. This will result in a faster triggering of alarms or relays if a sudden catastrophic failure occurs. Pressing the switch after the limit is reached has no effect.

Pushing the down switch will slow down the A/D converter and increase its accuracy. This will improve the ability to resolve low pressure readings. If a certain speed is desired, press the UP or DOWN switch three times and then press the other switch to select the other speed.

On older units. There will be no indication of the operating speed other than the least significant digits of the display will tend to run at higher speeds. On units with software version 1.60 and above, press the ZERO switch to display the decimation ratio (filtering). The larger the ratio, the longer the response time.

EEPROM Calibration Restoration

There are interlocks built into the CAL mode to minimize the chance of accidental alteration of the calibration coefficients, but if calibration alteration does occur, the EEPROM calibration data can be restored in the RUN mode by pressing the UP and DOWN switches simultaneously (RUN light will flash), then press the "ZERO" switch, UP and DOWN switches (all three) simultaneously.

This will not correct the calibration if the tube has become contaminated or damaged. This reset will not affect the gas selection, units or setpoints.

Also see unit's mode for default calibration restoration.

3.3. High and Low Set Point Modes

The Model 2002 provides TTL outputs for process control. The I/O cable is attached via a 9-pin sub-D connector to the rear panel of the control unit. The pinout is shown in Figure 4.2.

To view the high set point, place the Model 2002 in the HIGH mode by pressing the MODE switch to illuminate the HIGH light and no other mode light. The display will show the set point selected. During normal operation the alarm light will illuminate and the TTL output (pin # 3) will go high (+5 V) if the pressure exceeds the set point.

Similarly, to view the low set point access LOW mode by pressing the mode switch until the LOW light is lit and no other mode light is illuminated. During normal operation, the LOW light will illuminate and the LOW alarm TTL output (pin # 4) will go high (+5 V) if the pressure becomes less than the set point.

The alarm lights cannot indicate an alarm condition while in the set point modes. Therefore, it is advisable not to leave the instrument in these modes for extended periods.

To adjust a set point, press the mode switch until the set point is viewed. Then simultaneously press the UP and DOWN switches. The active mode light will now flash indicating that the interlock has been bypassed and the set point can be adjusted. The display shows the present set point.

Enter the new set point by using the UP and DOWN switches. Press and hold the UP switch to increase the set point and the DOWN switch to decrease the setpoint. Allow a few seconds for the circuitry to respond. Holding the button for an extended period of time, it will increase the adjustment rate. Release the button and press again to get finer control of the exact trigger point.

At this point, the new set point is in temporary memory. If the instrument were unplugged now, the Model 2002 would revert back to the original set point upon restarting. Return the 2002 to the RUN mode to store the set point in permanent memory.

Once the interlock has been bypassed in the HIGH mode, it will stay active until the CAL mode is entered. This will allow the user to set both setpoints without repeating the interlock bypass.

3.4. CAL Mode

Optimal performance of the Model 2002 is achieved by performing in situ adjustments to the calibration coefficient in the CAL mode. There are three calibration coefficients. These are the zero coefficient, the midrange coefficient and the atmosphere coefficient. Once a tube has been fully calibrated the midrange coefficient should never need further adjustment, but it may be helpful to adjust the zero coefficient or the atmosphere coefficient under certain situations. Even though the operator inputs may be identical for adjustment of all three coefficients, microprocessor will detect the power level of the tube and adjust the proper coefficient for pressure level of the adjustment.

The CAL MODE presupposes that the operator is applying a known pressure of the correct gas composition (see GAS MODE). The factory calibration points are 800 Torr, 7 Torr, and $<1e-6$ Torr. The user's calibration points are not required to be exactly those values, but should be somewhat close, and must be within the ranges shown in the following figure. The HPM-2002 detects the voltage signal within the sensor tube, which is converted and displayed as a pressure reading. The resulting pressure reading determines which of the three coefficients will be adjusted.

To adjust a calibration coefficient press the MODE switch until the CAL light is illuminated. Then simultaneously press the up and down switch. The CAL light will now flash indicating that the interlock has been bypassed and the calibration can be adjusted. Press and hold the up switch to increase the displayed value or the DOWN switch to decrease the displayed value. If the switch is held down for an extended period of time the adjustment rate will start to increase. Release the switch and then press and hold again to regain finer control of the displayed number.

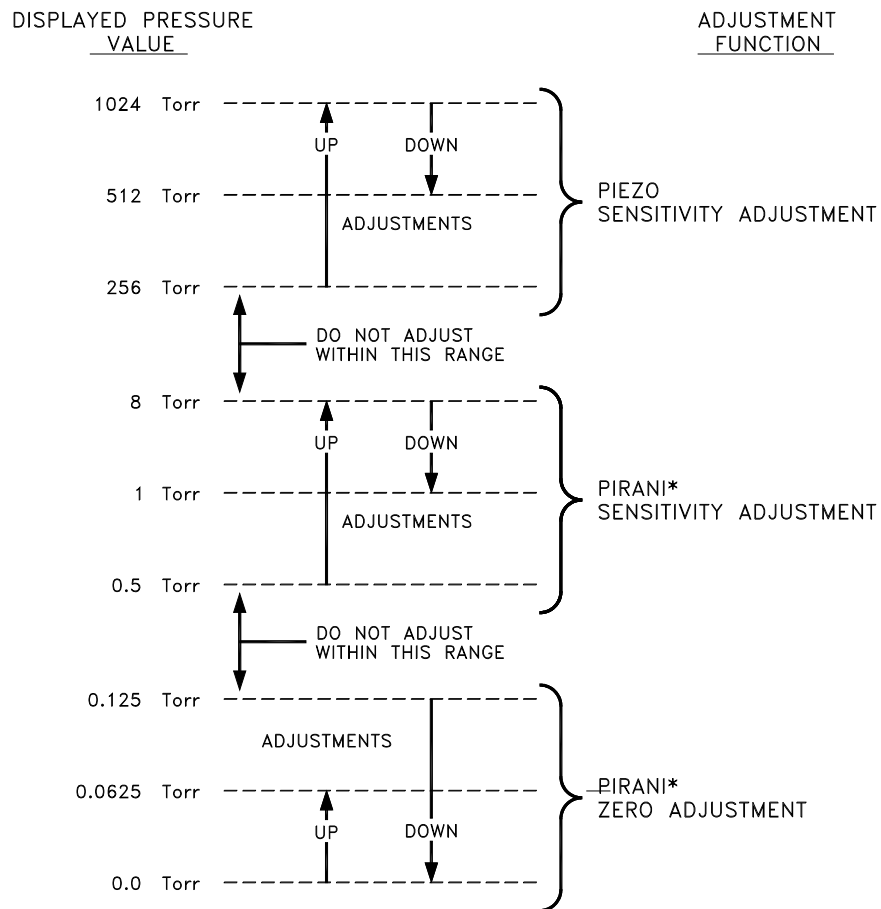

*CAUTION: GAS COMPOSITION SENSITIVE

An important point to be noted is the fact that after the adjustment, the new calibration coefficient is only in temporary memory. If the instrument were unplugged at this point, it would revert back to the original displayed value upon restarting. Place the Model 2002 back in the RUN mode to store all of the current calibration coefficients in permanent memory.

To perform a full calibration on the Model 2002 system, first use the Zero Coefficient Adjustment Procedure. Followed by the Midrange Coefficient Adjustment Procedure, and finally perform the Atmosphere Coefficient Adjustment Procedure.

Zero Coefficient Adjustment

The zero coefficients corrects for the constant power level which is present over the entire pressure range. Typically, this adjustment corrects for low pressure errors. The instrument will need to be re-zeroed often if measurements are being made in the 10⁻⁴ Torr range, especially if the ambient temperature changes. The transducer may have a temperature coefficient of up to 2x10⁻⁴ Torr/oC. The instrument remote zero input will allow an external gauge such as an ion gauge to automatically re-zero the Model 2002 whenever the pressure drops below the desired pressure level (if it has a TTL output).

NOTE: Do not attempt to zero the Model 2002 in pressures above 10⁻² Torr; the microprocessor will not accept a zero above this pressure.

To manually adjust the zero uses the following procedure:

1. If possible, evacuate the vacuum system into the low 10⁻⁶ Torr (1.33x10⁻⁶ mbar) range or as low as possible below 10⁻⁴ Torr.
2. Allow the sensor to operate in this condition for a minimum of 15 minutes.

3. Place the instrument in the CAL mode, then simultaneously press the UP and DOWN switches to bypass the interlock. The CAL light will start to flash indicating that the calibration mode has been activated.
4. Press the ZERO switch once if below 6×10^{-5} Torr otherwise use the UP and DOWN switch to adjust the display of the Model 2002 to match the pressure indicated by the reference. If using the UP and DOWN switch to adjust the display, wait 20 seconds between presses at very low pressure to allow the adjustment to take affect the data to settle.
5. The unit is now fully zeroed. Place the Model 2002 back in the RUN mode to store the zero in permanent memory.

Midrange Coefficient Adjustment

The midrange coefficient corrects for errors in the slope of the power curve of the thin film Pirani. Typically, this is due to the geometry of a particular sensor and will only need to be performed once in the lifetime of the sensor. This adjustment might be needed if a full calibration is being performed in a gas other than nitrogen. The zero adjustment will need to be performed before making this adjustment.

To adjust the midrange coefficient use the following procedure:

1. Evacuate the vacuum chamber and refill with the desired gas to a pressure of 7 Torr, as indicated by a reference vacuum gauge.
2. Press the MODE switch repeatedly until the CAL mode is illuminated.
3. Simultaneously, press both the UP and DOWN switches. The CAL light will start to flash, signaling that the calibration can now be conducted.
4. Press, hold and release the UP and DOWN switches as necessary to adjust the display to match the pressure indicated by the reference. Note: It may be necessary to hold the desired switch down for a few seconds before any movement is seen.
5. Press and release the MODE switch as necessary to return the 2002 to the RUN mode and store the coefficients to permanent memory.

Atmosphere Coefficient Adjustment

If a reference high pressure gauge is not available, the ambient barometric pressure acquired from the weather channel or other weather service can be used to adjust the proper reading.

To adjust the atmosphere coefficient, use the following procedure:

1. Press the MODE switch a sufficient number of times to enter the CAL mode.
2. Simultaneously, press both the UP and DOWN switches to bypass the interlock. The CAL light will start to flash, signaling that the calibration can now be conducted.
3. Press, hold and release either of the UP or DOWN switches as necessary to adjust the display to match the pressure indicated by the reference. Note: It may be necessary to hold the desired switch down for a few seconds before any movement is seen.
4. Press and release the MODE switch as necessary to return the Model 2002 to the RUN mode and store the coefficients to permanent memory.

3.5. GAS Mode

The Model 2002 can provide true pressure measurements in many gas environments. At pressure levels above 32 Torr where the direct force piezoresistive sensor is operative, the instrument is gas composition insensitive and measures the true pressure regardless of gas composition. The Pirani is gas composition sensitive so below 32 Torr, the actual composition must be known and the Pirani calibrated in that gas. When the vacuum system's gas composition is dominated by a single gas species (for example, during system venting with an inert gas), the user can enter a gas selection into the Model 2002. To view the gas selection, place the instrument in the GAS mode and reference Table 1.

The Model 2002 is factory set to display N₂ pressure readings. To select a different gas, refer to Table 1 to find the number code of the gas to be entered. Press the UP and DOWN switches simultaneously, the GAS

TABLE 1	
Gas Mode	Gas
Displayed Number	
0.0.....	Nitrogen
0.1.....	Argon
0.2.....	Helium
0.3.....	Water Vapor
0.4.....	Custom

light will now flash. Use the UP and DOWN switches to individually select the desired code. Return the Model 2002 to the RUN mode.

Note: Factory calibration is performed using nitrogen only. Displayed pressure measurements using other gases are based on established gas thermal conductivity data.

3.6. UNITS Mode

The Model 2002 can display the measured pressure in different pressure units, Torr, mbar or Pascal. To switch between these units press the MODE switch until the UNITS field is lit. Press the UP and DOWN switches simultaneously. The UNITS light will now flash. Use the UP and DOWN switches individually to select the desired unit.

The unit's mode is also used to display the RS-485 address, (see section 6.3).

A commonly used unit is mTorr which is also known as the micron (short for micron of Hg). One Torr is equal to 1000 mTorr. The table below illustrates how to interpret the display in mTorr.

mTorr Conversions

1 mTorr	=	1.00 x 10 ⁻³ Torr
10 mTorr	=	1.00 x 10 ⁻² Torr
100 mTorr	=	1.00 x 10 ⁻¹ Torr

Table 2 gives conversion factors for the most often used pressure units.

TABLE 2					
	Torr	atm	mbar	Pa	psi
Torr (mm Hg)	1	1.32x10 ⁻³	1.3332	133.32	1.934x10 ⁻²
mTorr (micron Hg)	10 ⁻³	1.32x10 ⁻⁶	0.00133	0.13332	1.934x10 ⁻⁵
atm (athmosphere)	760	1	1013.23	1.013x10	14.7
mbar (millibar)	0.75	9.869x10 ⁻⁴	1	100	1.45x10 ⁻²
Pa	7.5x10 ⁻³	9.869x10 ⁻⁶	0.01	1	1.45x10 ⁻⁴
psi (lb/in)	51.72	6.805x10 ⁻²	68.953	6895.3	1

Default Calibration Restoration

The UNITS mode is also used to load default calibration data in rare cases where the transducer EEPROM has become corrupted. The default calibration data should be considered an approximate calibration because the values entered in the controller's software are based on averaged data collected over a large number of transducers. While this type of calibration download is not a true calibration, it does allow the user to return the unit to a reasonable status from which a full calibration can be easily performed.

4. Rear Panel Description

A schematic of the rear panel of the Model 2002 control unit is shown in Figure 4.2 (Rear Panel Figure). The transducer is connected to the control unit via a female 9-pin “D” connector on the rear panel. An I/O cable can be connected via a male 9-pin “D” connector on the rear panel. The I/O cable provides an analog output signal, a remote zero input capability, high and low alarm TTL outputs, and a + 5 VDC Power Supply Output. The I/O cable also provides an analog ground and a digital common.

4.1. Remote Zero Input

The Model 2002 can be zeroed remotely via the I/O cable using the remote zero input line. Upon setting this line to TTL low level, the instrument will set its current pressure reading to zero. A common application of this feature is to utilize a process control output from a high vacuum gauge (for example an ion gauge controller) to automatically zero the Model 2002 whenever the pressure is below the low 10⁻⁵ Torr range. A Digital Common is provided on pin # 5 which can be used with relay contacts or switch contacts to remotely zero the instrument.

4.2. Analog Output

The Model 2002 provides an analog voltage output signal (0.5 VDC linear per decade) for process control and for pressure monitoring. A plot of the analog output signal as a function of pressure is shown in Figure 4.1 . Note that the output voltage is directly proportional to the pressure over each complete decade (see detailed region in Figure 4.1) and that each decade has a different linear slope.

If the analog output voltage is being used in a data acquisition system, the following formulas can be used to calculate pressure.

Above an indicated pressure of 103 Torr, the analog output signal will be +5 VDC. Below the minimal displayable pressure of 1 x 10⁻⁴ Torr, the analog output will be 1.0 VDC.

$$V = \frac{(EXP + 6)}{2} + \frac{(MANT - 1)}{18}$$

The analog output voltage is given by the following equation:

Where EXP is equal to the exponent of the displayed pressure.

$$\begin{aligned} & EXP = -2 \\ & MANT = 1.53 \\ V &= \frac{(-2 + 6)}{2} + \frac{(1.53 - 1)}{18} \\ &= 2 + 0.294 \\ & [= 2.0294VDC] \end{aligned}$$

Example: P=1.53x10⁻²

$$\begin{aligned} & EXP = -2 \\ & MANT = 9.87 \\ V &= \frac{(-2 + 6)}{2} + \frac{(9.87 - 1)}{18} \\ &= 4 + 0.4928 \\ & [= 4.4928VDC] \end{aligned}$$

If the analog output voltage is being used in a data acquisition system, the following formulas can be used to calculate pressure.

$$EXP = INT(2 * V) - 6$$

$$MANT = 1 + 18 * V - 9 * (EXP + 6)$$

$$Pressure (Torr) = Mant \times 10^{EXP}$$

Therefore,

Note that the INT function simply returns to the first digit in a number.

Examples:

$$INT(2.56) = 2$$

$$INT(9.87) = 9$$

Voltage to pressure conversion example:

Given

$$V = 2.35 \text{ Volt}$$

First calculate the exponent;

$$EXP = INT(2 * 2.35) - 6$$

$$= INT(4.7) - 6$$

$$= INT(4) - 6$$

$$= -2$$

Next calculate the mantissa;

$$MANT = 1 + 18 * V - 9 * (EXP + 6)$$

$$= 1 + 18 * (2.35) - 9 * (2 + 6)$$

$$= 1 + 42.3 - 36$$

$$= 7.3$$

Finally the pressure is given by;

$$Pressure (torr) = MANT \times 10^{EXP}$$

$$= 7.3 \times 10^{-2} \text{ Torr}$$

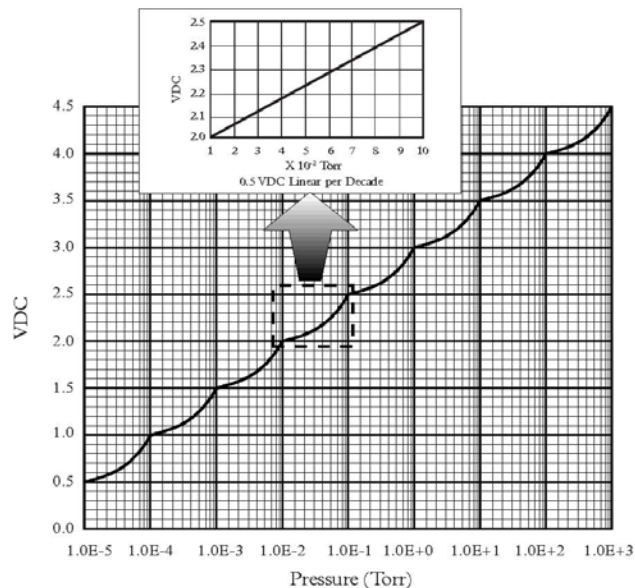

MODEL 2002 Analog Output
VDC (volts) -vs- Pressure (Torr)

Figure 4.1

4.3. TTL Outputs

TTL outputs are provided for process control. High and Low set points are entered on the front panel (see Section 3.4) and TTL signals are generated on the I/O cable in the following manner:

1. When the pressure as indicated by the Model 2002 is above the High set point, the High signal line (pin #3) will be set to a TTL high level (+5 VDC). When the indicated pressure is below the High set point, the High signal line (pin#3) will be set to a TTL low level (+0 VDC).
2. When the pressure as indicated by the Model 2002 is below the Low set point, the Low signal line (pin #4) will be set to a TTL high level (+5 VDC). When the indicated pressure is above the Low set point, the Low signal line (pin #4) will be set to a TTL low level (+0 VDC).

These TTL signals are used for a variety of applications. With these signals, the user has the capability to turn off/on various equipment such as valves, flow controllers, pumps, heaters, and safety equipment.

4.4. Power Entry Module

The AC power for the Model 2002 enters the instrument through a power entry module that contains a fuse, on/off switch and an IEC 320 power inlet.

The fuse is rated for 250 V, 1/4 A. It can be accessed by unplugging the AC cord and prying the fuse compartment open with the tab and slot in the power inlet chamber. There is a spare fuse in the compartment within the fuse holder.

LOW SETPOINT RELAY OPTION BOARD CONNECTOR (MALE) HIGH SETPOINT RELAY

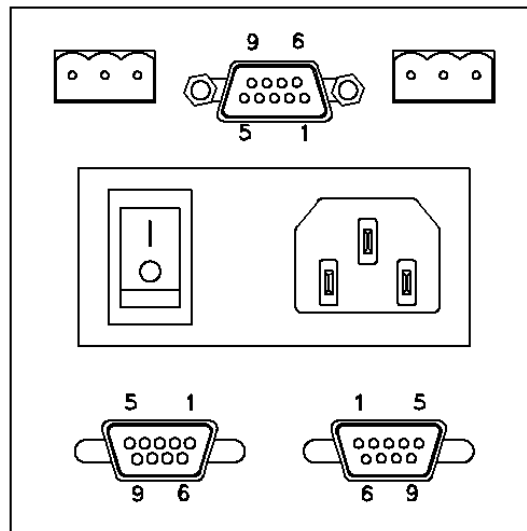

TRANSDUCER CONN.
(FEMALE)

STANDARD
I/O CONNECTOR

**Model 2002
Rear Panel Detail**

Fig 4.2

Analog 0-10V OPTION

BOARD CONNECTOR

Pin#	<u>Connection</u>
1	Analog Out 1 (1024 Torr) High
2	Analog Out 1 (1024 Torr) Shield
3	Analog Out 1 (1024 Torr) Low
4	
5	
6	
7	Analog Out 2 (1000 mTorr) Low
8	Analog Out 2 (1000 mTorr) High
9	Analog Out 2 (1000 mTorr) Shield

4-20mA OPTION

BOARD CONNECTOR

Pin#	<u>Connection</u>
1	I-Loop Out (+) 1024 Torr
3	I-Loop In (-) 1024 Torr
8	I-Loop Out (+) 1000 mTorr
7	I-Loop In (-) 1000 mTorr

SENSOR CONNECTOR

Pin#	<u>Connection</u>
1	Sensor
2	Bridge (sense)
3	Bridge-Power
4	Reference
5	Common
6	Common (sense)
7	Piezo / Memory
8	+12 VDC
9	N/C

I/O CONNECTOR

Pin#	<u>Connection</u>
1	Analog Output
2	Analog Common
3	High Setpoint
4	Low Setpoint
5	Digital Common
6	Remote Zero
7	+5V

5. Theory of Operation

The Model 2002 transducer is comprised of two very different sensors which provide a span of measurement extending from 1000 Torr down to less than 1×10^{-4} Torr. The piezoresistive device is a direct force sensor which provides pressure indication from 1000 Torr down to less than 1 Torr. The thin film Pirani device is a thermal conductivity sensor that provides pressure indication from 100 Torr down to less than 1×10^{-4} Torr. The two decade overlap in measurement range is convenient for smooth transition either descending or ascending in pressure. Both sensors are small micro machined die that are bonded to a Au coated Al_2O_3 preform (stress isolation) which in turn is bonded to a TO-8 header. The header is resistance welded into a 316 stainless steel envelope as shown in Figure 5.1.

5.1. Piezoresistive Sensor

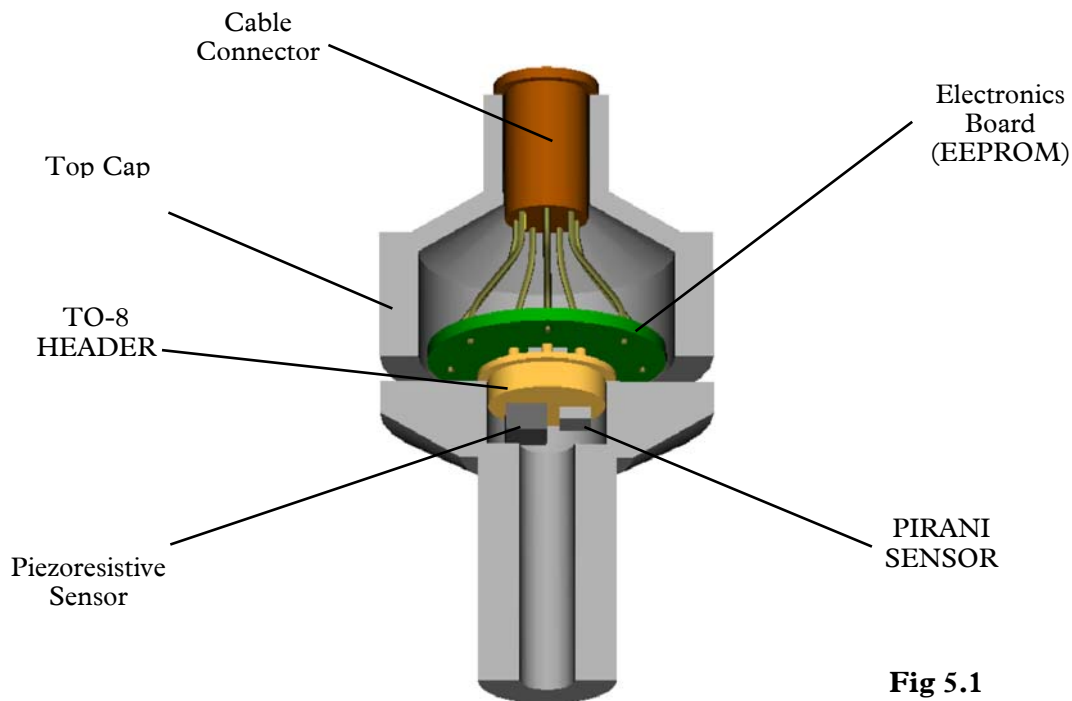

Fig 5.1

Dual Sensor Emulation

Figure 5.2 shows a typical schematic of a B implanted Wheatstone bridge network in a Si diaphragm inverted box type geometry. The inside of the box is evacuated during anodic bonding to a Pyrex substrate. The membrane has maximum deflection at atmosphere (or higher pressure) and the membrane resistances change value as the differential pressure is decreased during pump down. The resulting differential output is

$$V_o = SPV + V_1$$

where

S is the sensitivity
P is the pressure
V is the applied bridge voltage
V₁ is the no load output voltage

Since the sensitivity changes so dramatically with temperature, some correction is required for compensation. The change in output voltage

To insure temperature invariance,

$$\frac{dV_o}{dT} = P \left(\frac{SdV}{dT} + \frac{VdS}{dT} \right)$$

$$\frac{dV_o}{dT} = 0 \quad \text{Therefore} \quad \frac{1}{V} \frac{dV}{dT} = - \left(\frac{1}{S} + \frac{dS}{dT} \right)$$

This requires for any change in sensitivity to be countered by an equal but opposite change in applied voltage. The temperature compensation is a network of temperature dependent resistive components and fixed temperature compensation current source compensation, $TCR = -TCS$.

Sensitivity of the sensor is proportional to the sensor factor (K), the strain gauge positioning of the diaphragm (f) and the diaphragm geometry (q) thus $S\mu Kfq$. Once the defining geometry of the resistive film and piezo membrane have been established, the sensor factor is dependent on the crystal orientation of the membrane material, the doping level and diffusion parameters and the strain gauge geometry. The sensor factor is essentially the change in resistance for a change in strain or,

Boron ion implanted doped Si matrix resistance elements are employed as shown in figure 5.2.

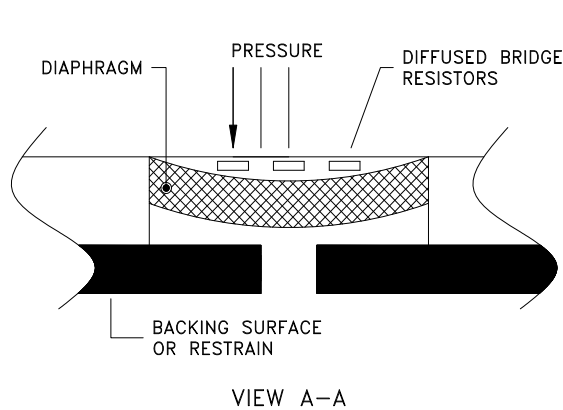

$$K = \frac{\Delta R}{\frac{R}{\frac{\Delta L}{L}}}$$

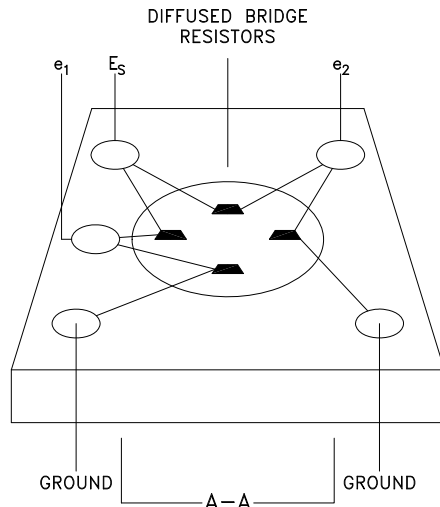

The die is electro statically bonded on to a Pyrex substrate in a good vacuum so that the die cavity is evacuated; this provides maximum deflection at atmospheric pressure. When the sensor is exposed to vacuum the deflection becomes less and less as the die cavity pressure and the vacuum system pressure equalizes. Eventually the strain in the membrane due to DP becomes zero and only the residual strain in the lattice remains. The bridge resistive elements are oriented to give maximum change in bridge resistance which in turn gives maximum voltage out for a given strain.

5.2. Pirani Sensor

Figure 5.3a shows a thin film Pt resistive element on a one micron thick Si₃N₄ continuous membrane surrounded by a thin film Pt reference resistor on a Si substrate. The membrane is heated to a constant 8°C above ambient temperature that is monitored by the substrate resistor. The membrane resistor is approximately 60 Ω and a constant substrate to membrane resistance ratio is maintained at 3.86. Figure 5.3b shows the Pirani die in cross section. A parallel Si lid is eutectically bonded to the Au pads and sits 5 microns above the membrane. As shown, this dimension gives a Knudsen number of greater than 0.01 up to atmospheric pressure, which insures a molecular flow component. At 10 Torr the region above the membrane is totally in the molecular flow regime and thus provides a relatively linear output verses pressure overlapping the linear output versus pressure of the piezo.

The measurement technique is to produce an output signal that is proportional to the power supplied to the heated resistor by using the product of the current and voltage. This rejects errors introduced by resistance changes since the sensor resistance is no longer part of the power equation.

A signal proportional to the power is obtained by multiplying the voltage across the heated sensor and the voltage impressed by the direct current across a constant series resistance. The power supplied to the sensor resistor must equal the heat dissipated (E_t). The three main heat loss routes from the heated sensor are thermal conduction through the silicon nitride membrane to the silicon substrate (E_s) radiation losses (E_r) and thermal conduction through the gas to the silicon substrate (E_g); thus, as shown in Figure 5.3c,

$$E_t = E_s + E_r + E_g$$

The first term, E_s, is dependent on the thermal conductivity of the silicon nitride (K), the temperature difference (ΔT) between the heater and silicon substrate and geometric factors (AM & L). E_s is given by

$$E_s = (K \Delta T A_m)/L$$

A_m is the membrane cross sectional area through which the heat transfer occurs. This is, approximately, the outer circumference of the membrane multiplied by the membrane thickness. L is the distance from the edge of (R_s) the heated sensor resistor to the silicon substrate.

For any particular sensor, all of the factors, except DT, are constants dependent on its construction. The DT is held constant by the control circuit. The thermal loss through the silicon nitride will be a constant value independent of the thermal conductivity and pressure of the gas.

Radiation is another source of thermal losses. It can be determined from

$$E_r = \sigma \epsilon (T_h^4 - T_a^4) A_s$$

Where

σ	=	Stefan-Boltzmann radiation constant
ϵ	=	thermal emissivity of the silicon nitride membrane
A_s	=	surface area of the heated portion of the membrane
T_h	=	temperature of R _s
T_a	=	ambient temperature

This radiation loss is also independent of the thermal conductivity of the gas. It is somewhat dependent upon the absolute temperature of R_s and the ambient temperature, but since DT is kept to less than 20°C, this loss is only approximately 10% of E_s. If ambient changes are small compared to the absolute values of the temperature this loss can approximated as a constant with temperature.

Since the first two losses are essentially constant at high vacuum for a given sensor, we can measure these losses and subtract them from the input power which leaves only the rate of heat transmission through the gas (E_g).

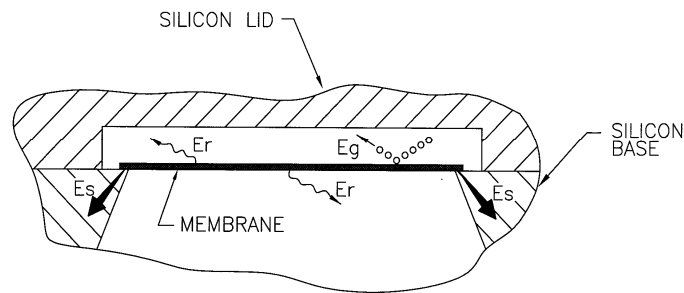
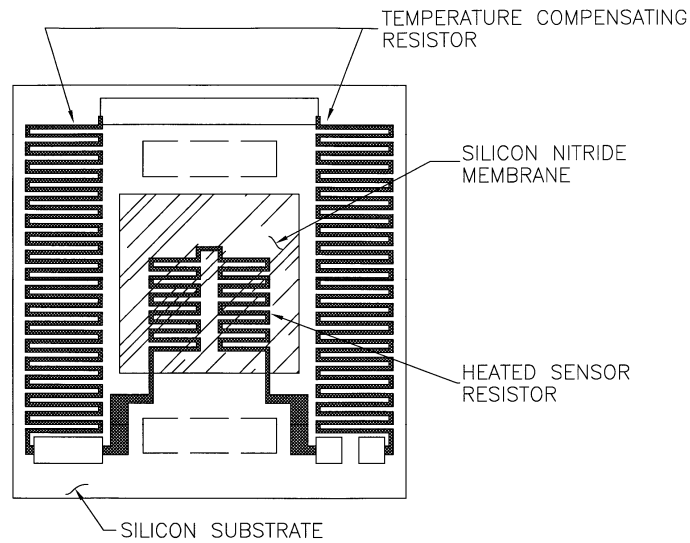

In the viscous flow regime, the E_g loss is directly dependent on the thermal conductivity of the gas (K_g), the surface area of the membrane, the differential temperature and is inversely proportional to distance between the membrane and the lid. It can be written as

$$E_g = (K_g DT A_s)/D_x$$

The thermal conductivity of the gas is essentially constant when in viscous flow where the Knudsen number (Kn) is less than 0.01. In the viscous flow regime there is no change in sensor output with pressure since all of the losses are constants with pressure.

In the molecular flow regime where ($Kn > 1$) the thermal conductivity of the gas becomes directly proportional to the gas pressure as shown below. We can expect then that E_g will be constant at high pressures and directly proportional to the pressure at low pressures. The energy loss E_g , changes between these two controlling equations as the system passes through the transition region ($0.01 < Kn < 1$).

$$E_g = arL_t(273/T_h)^{1/2}(T_h - T_a)AgP$$

Where

- ar = accommodation coefficient
- L_t = free molecule thermal conductivity
- T_h = temperature of heated membrane

- T_a = ambient temperature
- P = pressure
- A_g = surface area of the heated portion of the membrane

For nitrogen at a pressure of 760 Torr and a temperature of 20°C the mean free path (λ) is less than 1×10^{-7} meters and is inversely proportional to pressure. Since the thermal transfer distance (D_x) is a few micrometers, this sensor will remain in the molecular flow regime at a much higher pressure (10 Torr) than is typical for a thermal vacuum gauge. This extends the linear response part of the output curve up into the 1 Torr range. The nonlinear transition region will extend up to 1000 Torr.

5.3. Dual Sensor Operation

The microprocessor in the control unit continuously monitors the outputs of both the piezoresistive sensor and the Pirani sensor. Figure 5.4 shows representations of the sensors output over the pressure range from 10^{-5} Torr to 10^{+3} Torr. The microprocessor uses the output of the piezoresistive sensor at high pressures (>32 Torr) and uses the output of the Pirani sensor at low pressures (<8 Torr). In the crossover region, a software averaging algorithm ensures a smooth transition between the two sensors.

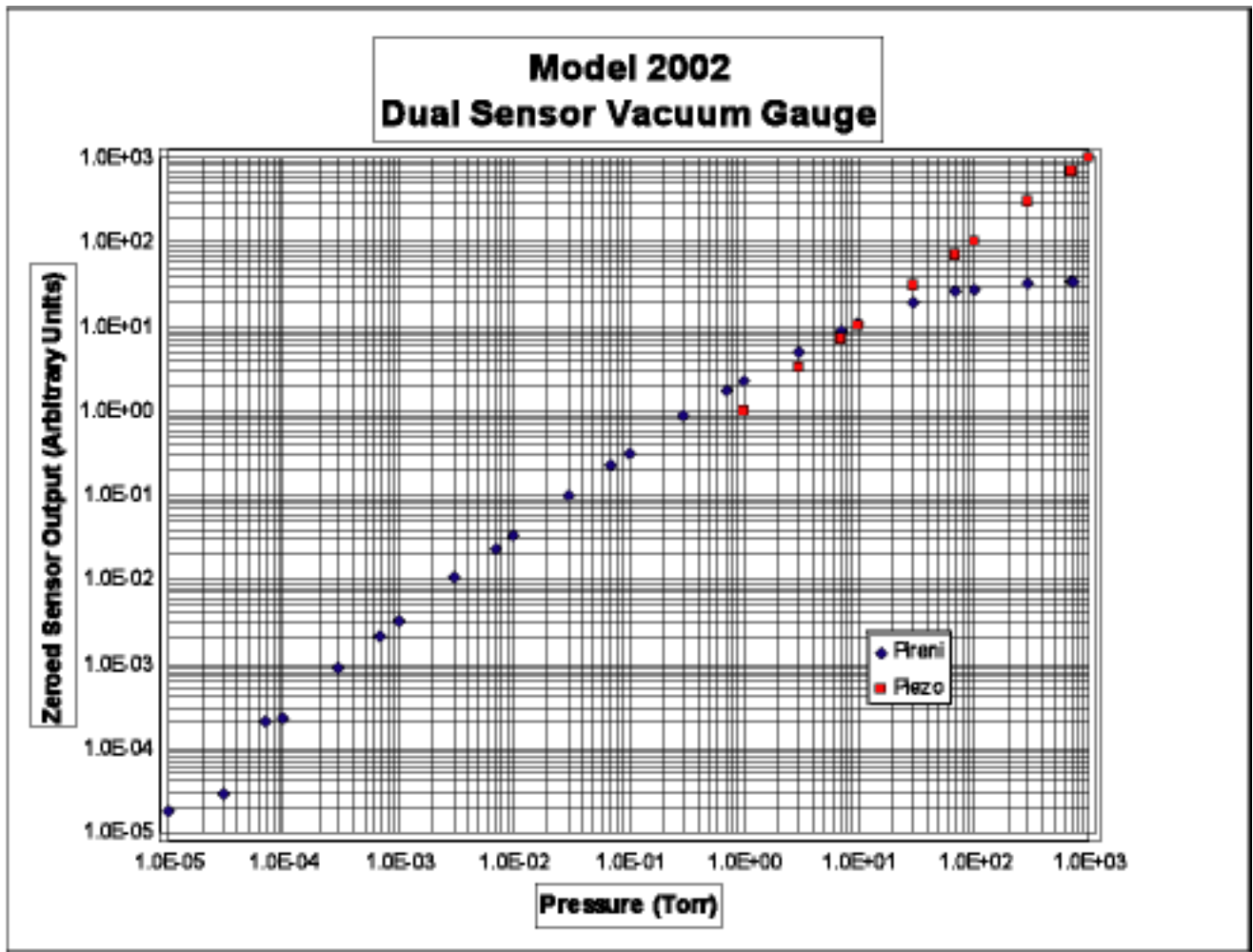

Fig. 5.4

6. Communications Option Board

Both RS-232 and RS-485 communication interface boards are available as an option for the Model 2002. The communication option boards allow data to be output to a host computer with the appropriate interface. Connection to the RS-232 or RS-485 communication interface boards are via a 9 pin D-subminiature female connector.

6.1. RS-232-E Interface Specifications

Format..... EIA standard RS-232-E, full-duplex, no handshaking, asynchronous
 Data Rate 9600 baud
 Character Length Eight data bits
 Parity No parity
 Stop bits One stop bit

A common application of the RS232 version of the HPM-2002, is to connect the pressure gauge directly to the serial port of a PC. This is done by first wiring a communication cable in the manner shown below.

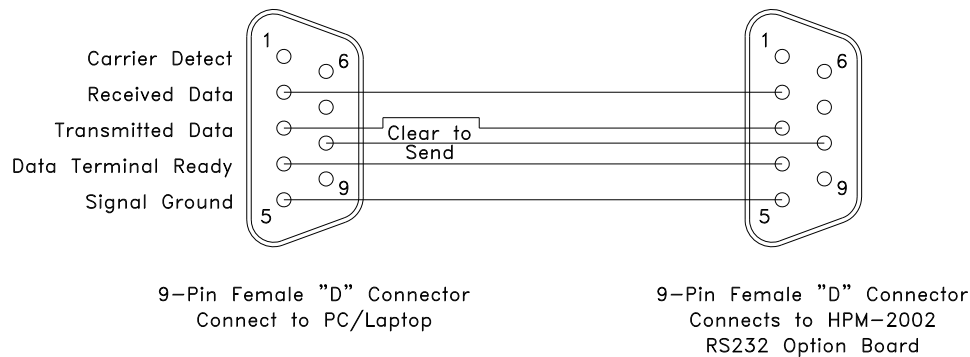

PIN	MNEMONIC	SIGNAL	DESCRIPTION
2	TX	Transmit Data	Transmits data within RS-232-E voltage levels
3	RX	Receive Data	Accepts data within RS-232-E voltage levels
5	SG	Signal Ground	Establishes the common ground reference potential for all interchange circuits
when 232-E.			Communicating via RS-232-e
4	CTS	Clear to Send	Host computer ready to accept data. (Reserved for future use, not implemented by present software).
8	RDY	Ready	Ready to receive data (always high, not implemented by present software).

6.1.1. Interface Connector Pin Assignments for RS-485

(Full duplex-4 wire)(Jumper position 2-3).

PIN	MNEMONIC	SIGNAL	DESCRIPTION
2	TX+	Transmit +	Differential data signal levels to the RS-485 bus
8	TX-	Transmit -	
3	RX+	Receive +	Differential data signal levels to the RS-485 bus
4	RX-	Receive -	

6.1.2. For RS-485 (Half Duplex – 2 wire)

(Jumper position 1-2).

PIN	MNEMONIC	SIGNAL	DESCRIPTION
2	TX+/RX+	Transmit +/Receive+	Differential data signal levels to the RS-485 bus
8	TX-/RX-	Transmit -/Receive -	

6.2. Interface Connector Pin Assignments for RS-232

Note: an alternate method of connecting to a 2 wire bus is to leave the interface configured for full duplex and externally connect pins 2 and 3 to the (+) bus and pins 4 and 8 to the (-) bus.

6.3. Operation of the Serial Interface

Communication with the serial interface of the Model 2002 is via an ASCII data string. In the RS-232 mode the command message consist only of a command string and the terminator. The attention character and address string are not required, but if they are used they **MUST** be valid. If all components of the ASCII data string are valid the command will be accepted and executed. The RS-232 mode is sometimes referred to as point-to-point mode since only one device may be connected to the controller at any given time.

A message to the Model 2002 in the RS-485 mode consists of an attention character followed by the address string, the command string, and the terminator. If all components of the ASCII data string are valid the command will be accepted and executed. The RS-485 mode is also referred to as multipoint mode since up to 31 devices may be connected to the same controller in a network scheme.

The RS-485 address may be display on the model 2002 front panel (with software version 1.60 or higher). Press the MODE switch until the units field is lit, press both the UP nad DOWN switches simultaneously. The units light will now flash. Press the ZERO switch to display the RS-485 address (the address is displayed in it's decimal form). Use the UP or DOWN switch to modify the address. Use the MODE switch to exit this function and save the new address into EEPROM memory.

COMMAND SYNTAX

In the following examples of syntax codes, the special characters are explained:

The characters in square brackets [] represents a command string, either upper or lower case command characters accepted. All characters must follow each other in the string with no spaces or other characters.

The characters within wavy brackets { } contain choices for the appropriate command.

The characters within the symbols < > are the common abbreviations for the one digit ASCII control codes which they represent, (e.g. <CR> represents carriage return).

When entering more than one command in the same data string, they must be separated by a comma.

All command strings must be followed by the terminator character (carriage return <CR>, also known as ENTER).

When a lower case character is present in an example it represents an option.

Character	Description	Valid Inputs:
a	RS-485 Address (hexadecimal 0-9, A-F).....	01 - FF
m	Most Significant Digit Of Mantissa.....	1 - 9
d	Decimal Digit	0 - 9
e	Exponent	0 - 5
u	Unit Of Pressure.....	T, M, or P
,	Command Separator (comma)	N/A
<CR>	Command Terminator (carriage return).....	N/A

Interrogation Commands

Command Description	Format	Sample Response
Transmit Averaged Pressure	P<CR>	Pa: 1.23456e+0 Torr<CR>
Transmit Pirani Pressure	R<CR>.....	Pr: 1.98765e-3 Torr<CR>
Transmit Piezo Pressure	Z<CR>.....	Pz: 7.65432e+2 Torr<CR>
Transmit RS-485 Address	A<CR>.....	Multidrop Address: 01<CR>
Transmit Decimation Ratio	D<CR>	Decimation Ratio: 255<CR>
Transmit Selected Gas #	G<CR>	Gas#: 0<CR>
Transmit High Set point	H<CR>	Hi: 1.00000e+1 Torr<CR>
Transmit Low Set point	L<CR>.....	Lo: 1.00000e-2 Torr<CR>
Transmit Device Status	S<CR>	00044<CR>
Transmit Turnaround Delay	T<CR>	Comm Delay: 6<CR>
Transmit Selected Units	U<CR>	Torr<CR>
Transmit Software Version#	V<CR>.....	Hastings Instruments - Model 2002 Version 1.60 - (07-02-2002)<CR>

Parameter Modification Commands

Command Description	Format	Valid Range:
Modify High Set point	H={m.dd}E{+e}<CR>	1.00000e-9 to 9.99999e+9
Modify Low Set point	L={m.dd}E{-e}<CR>	1.00000e-9 to 9.99999e+9
Modify Selected Gas #	G={d}<CR>	0 To 4 (Decimal)
Modify Selected Units	U={u}<CR>	T, or M, {or P, if Available}
Modify Decimation Ratio	D={dddd}<CR>	63 To 7936..... (Decimal)
Modify RS-485 Address	*{aa}A={aa}<CR>	1 To FF (Hexadecimal)
Modify Turnaround Delay	*{aa}T={dd}<CR>	0 To 255 (Decimal)

Notes:

The setpoints may also be entered as a decimal number, e.g. [H=760.99<CR>] will be same as entering [H=7.6099E+2<CR>].

When inputting setpoint data, it should be entered in the same Units of Pressure as the presently selected Units of Measurement (i.e. Torr, mbar or Pascal). The data is only checked to be a valid number with a one digit exponent before being accepted. There are no limit checks on the data; the user is free to choose any value appropriate to his use of the instrument.

The Turnaround Delay and RS-485 address are unique to multipoint communications. In order to prevent inadvertent modifications of these parameters, the multipoint attention character and the Model 2002's present address [$\star\{aa\}$] MUST be used and are checked for validity before the command is executed.

If the RS-485 address is unknown, the 'UNIVERSAL ADDRESS' [$\star00$] may be used to set the address to a known value, e.g. [$\star00A=35<CR>$] will change the RS-485 address to 35.

Caution: Since all units will respond to the 'UNIVERSAL ADDRESS', make sure that only the unit to be modified is connected to the RS-485 Bus. If more than one unit is connected, this will result in all of the units being set to the same address.

The value entered for the Turnaround Delay is used to modify an internal timer which normally runs at ~8 millisecond, e.g. [$\star\{aa\}T=10<CR>$] will set the delay to ~80 milliseconds.

If the command syntax is not met or if the number is out of range, the HPM-2002 will respond with the ASCII codes for <bell>?<CR>, and the command will be ignored.

Calibration Adjustment Commands

Command Description	Format	Valid Range:
Set Full Scale Calibration	CF={m.d}E{e}<CR>.....	5.12e+2 to 1.023e+3 Torr
	6.83e+2 to 1.365e+3 mbar
	6.83e+4 to 1.365e+5 Pascal
Set Midpoint Calibration	CM={m.d}E{e}<CR>.....	4.00e+0 to 7.999e+0 Torr
	5.34e+0 to 1.066e+1 mbar
	5.34e+2 to 1.066e+3 Pascal
Set Low point Calibration	CL={m.d}E{e}<CR>.....	0 to 1.249e-1 Torr
	0 to 1.666e-1 mbar
	0 to 1.666e+1 Pascal

Notes:

The calibration adjustment data may also be entered as a decimal number, e.g. [CF=760.99<CR>] will be same as entering [CF=7.6099E+2<CR>].

When inputting calibration adjustment data, it must be within the valid range of the presently selected Unit of Measurement (i.e. Torr, mbar or Pascal). The data is checked to be valid before being accepted.

If the command syntax is not met, or if the number is out of range, the HPM-2002 will respond with the ASCII codes for <bell>?<CR>, and the command will be ignored.

Reset / Restore Commands

Command Description	Format	Notes:
Escape	<Esc>	Reset Command Buffer (Ignore prior Input)
Software Reset	/R<CR>	Reinitialize Software
Restore Factory Defaults	/#<CR>	Restore Calibration Register Default Values
Set Zero	/0 <CR>	Store Present Pressure as Instrument ZERO (if Piezo <32 Torr & Pirani <50 mTorr)
Force Zero	!/<CR>	Override Limit Checks And Store Present Pressure as Instrument ZERO

Device Status

When requested to transmit its status the Model 2002 responds with a five digit number which is explained in the following:

	Digit #	1	2	3	4	5
Serial Receiver Overflow	=	4				
Main Board EEPROM Error	=	2				
Probe EEPROM (any) Error	=	1				
Probe EEPROM Not Responding	=		8			
Probe EEPROM Read Error	=		1			
Probe EEPROM Checksum Error	=			4		
Probe EEPROM Verification Error	=			2		
Probe EEPROM Identification Error	=			1		
Communications Syntax Error	=				4	
Piezo Sensor Bad (voltage out of range)	=				2	
Pirani Sensor Bad (voltage out of range)	=				1	
High Setpoint Alarm (pressure exceeds setpoint)	=					4
Low Setpoint Alarm (pressure less than setpoint)	=					2
Gas# Changed (not the same as when unit last calibrated)	=					1

7. Relay Interface Option Board

The relay interface board is available as an option for the Model 2002. Additionally, relays may be added to either the Digital option Board (RS-232 or RS-485) or to the Analog option Board (0-10 Volts or 4-20mA). In either case the relays operate independently of the other options. The relay board allows the TTL logic setpoints (High, Low) to directly control two SPDT relays. Whenever the setpoint indicator light in the front panel is lit, the corresponding relay is energized. The relay contacts are rated for a maximum switching current of 250VA (resistive load). Connection to the relay contacts is made via connector mounted through the rear panel of the Model 2002. Screw terminals, on the mating connector, are designed for wire from 28 AWG through 14 AWG.

7.1. Relay Board Specifications

Each relay board consists of 2 Form C (SPDT) relays with the contacts wired in parallel.

Max. Switching power.....	120W, 250VA (2A @ 125VAC, 1A @ 250VAC)
Max. Switching voltage	220VDC, 250VAC
Max. Switching current.....	4A DC, AC
Max. Carrying current.....	6A DC, AC
UL/CSA rating	1.2A @ 125VAC
.....	1.2A @ 110VDC
.....	4.0A @ 30VDC

7.2. Relay Connector Pin Assignment

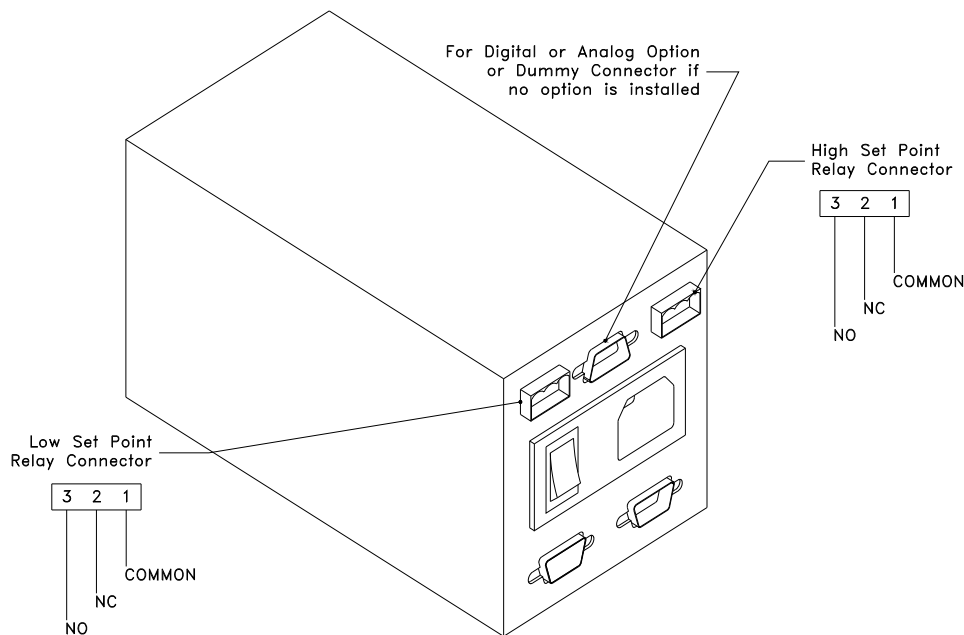

8. 4-20 mA Interface Option Board

The Relay option board in the Model 2002 operates off of the set points defined by the user and programmed into the Model 2002 microprocessor. For more information about configuring these set points refer to Section 3 of this manual.

The 4-20 mA interface board is available as an option for the Model 2002. This board provides dual current channels linearly proportional to the HPM 2002's pressure reading. Please note that use of the Model 2002 with this option requires a CPU with firmware for version 1.6 or later.

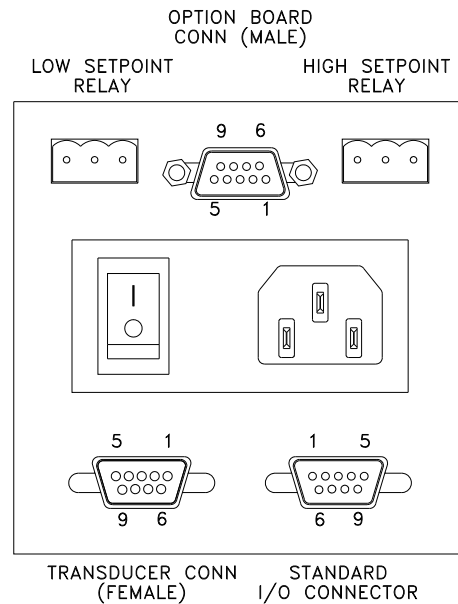

Model 2002
Rear Panel Detail

Fig 8.1

8.1. 4-20 mA Connector Pin Assignments

Interference

Pin	Connection
1.....	Internal loop power out (+) channel 1.
3.....	Loop in (-) channel 1.
8.....	Internal loop power out (+) channel 2.
7.....	Loop in (-) channel 2.

The 4-20 mA board can only be operated with internal loop power.

A schematic (Figure 8.2) is attached to show the proper method to wire into a loop.

Symptom: Fixed display, regardless of pressure

Action: 1. Check sensor for contamination.

8.2. Operation

The 4-20 mA output option board provides dual channel current output linearly proportional to the HPM 2002's pressure reading. The first channel corresponds to the higher pressure range (0-1024 Torr). The second channel corresponds to the lower pressure range (0-1000mTorr). The equations below give the output currents for a given pressure:

$$I(\text{channel1}) = 4\text{mA} + (P(\text{Torr})) * \left(\frac{16\text{mA}}{1024\text{Torr}} \right)$$

$$I(\text{channel2}) = 4\text{mA} + (P(\text{mTorr})) * \left(\frac{16\text{mA}}{1000\text{mTorr}} \right)$$

Note that for both channels, the output is always between 4mA and 20mA. Specifically, when the pressure is below 1 Torr, channel 1 current will be approaching 4mA. Also, when the pressure is above 1 Torr channel 2 current will be saturated at 20mA.

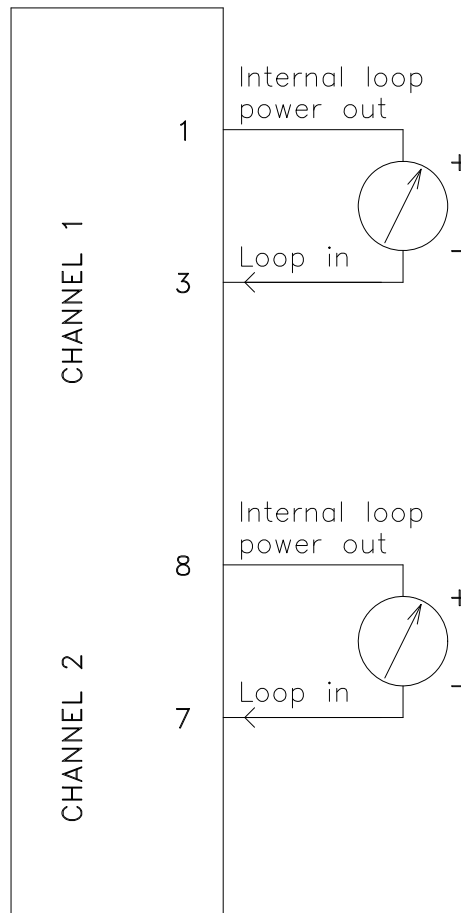

9. 0-10V Interface Option Board

The 0-10 V interface board is available as an option for the Model 2002. This board provides dual voltage channels linearly proportional to the HPM 2002's pressure reading. Please note that use of the Model 2002 with this option requires a CPU with firmware version 1.6 or later for proper operation.

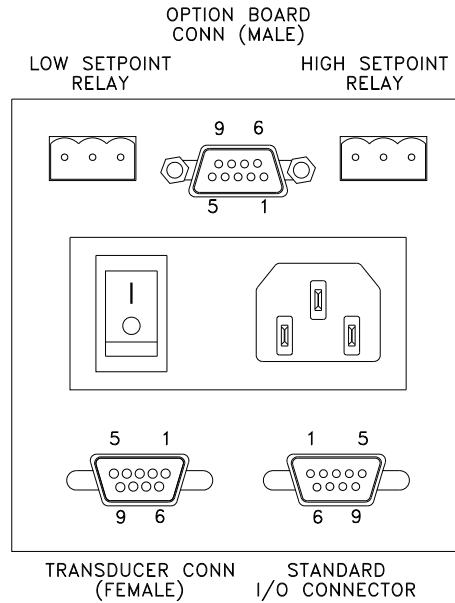

9.1 0-10V Interface Connector Pin Assignmets

<u>Pin</u>	<u>Connection</u>
1.....	Channel 1 Output (+)
2.....	Channel 1 Shield/Analog Common
3.....	Channel 1 Output
7.....	Channel 2 Output (-)
8.....	Channel 2 Output (+)
9.....	Channel 2 Shield/Analog Common

Both output channels are true differential and are short circuit protected with 100 Ω output impedance. While this allows either side of the output channel to be grounded, best results will be obtained by using a differential input measurement system. The output can be modified for single ended use, if necessary contact the factory for details.

The 0-10V output option board, provides voltage outputs proportional to the HPM-2002 pressure reading. The first channel corresponds to the higher-pressure range (0-1024 Torr). The second channel corresponds to the lower pressure range (0-1000mTorr). The equation below gives the output voltage for a given pressure.

$$V(\text{channel1}) = \frac{P(\text{Torr})}{100}$$

$$V(\text{channel2}) = \frac{P(\text{mTorr})}{100}$$

Where:

V (channel 1) is the voltage between pins 1 and 3,

V (channel 2) is the voltage between pins 8 and 7.

P is the indicated pressure.

10. Troubleshooting Guide

Symptom: Power on - No display activity.

Action:

1. Check for proper AC voltage at the outlet.
2. Ensure that the AC power cord connectors are firmly seated in their sockets. (at the outlet and at the instrument.)
3. Check the fuse.
 - a) Remove the power cord from the IEC-320 socket on the back of the instrument.
 - b) Pry the fuse holder out of the socket assembly by using a screwdriver in the small slot inside the IEC-320 socket.
 - c) Check the fuse that is in the fuse clamp. If it is found to be defective, remove it from the clamp. Press the spare fuse case out of the fuse holder body and insert the spare fuse into the fuse clamp.
 - d) Reassemble the power inlet assembly by reversing the above directions.
 - e) Check the power supply for proper operation
4. Check the AC/PCB connection.
 - a) Remove the front panel by removing the bezel and four phillips head screws. (Disconnect AC power prior to removal of the front panel.)
 - b) Slide the display board and the main PCB out of the case.
 - c) Verify that the white AC connector is firmly seated over all five pins of P4.
5. Check the display board connection.
 - a) Verify that the 13 pin SIP connector is firmly seated over all 13 pins of P3 and that the red strip is towards the rear of the case.
 - b) Verify that the 5 pin ribbon connector is firmly seated over all 5 pins of P2 and that the silver side is toward the case.
6. Consult the factory.

Symptom: Rapidly running, random digits on display

Action:

1. Consult the factory.

Symptom: Display shows decimal point and minus sign only

Action:

1. Check microprocessor.
 - a) Remove the front panel.
 - b) Verify that the microprocessor is properly seated in the chip carrier.
2. Consult the factory.

11. WARRANTY

11.1. Warranty Repair Policy

Hastings Instruments warrants this product for a period of one year from the date of shipment to be free from defects in material and workmanship. This warranty does not apply to defects or failures resulting from unauthorized modification, misuse or mishandling of the product. This warranty does not apply to batteries or other expendable parts, or to damage caused by leaking batteries or any similar occurrence. This warranty does not apply to any instrument which has had a tamper seal removed or broken.

This warranty is in lieu of all other warranties, expressed or implied, including any implied warranty as to fitness for a particular use. Hastings Instruments shall not be liable for any indirect or consequential damages.

Hastings Instruments, will, at its option, repair, replace or refund the selling price of the product if Hastings Instruments determines, in good faith, that it is defective in materials or workmanship during the warranty period. Defective instruments should be returned to Hastings Instruments, **shipment prepaid**, together with a written statement of the problem and a Return Material Authorization (RMA) number.

Please consult the factory for your RMA number before returning any product for repair. Collect freight will not be accepted.

11.2. Non-Warranty Repair Policy

Any product returned for a non-warranty repair must be accompanied by a purchase order, RMA form and a written description of the problem with the instrument. If the repair cost is higher, you will be contacted for authorization before we proceed with any repairs. If you then choose not to have the product repaired, a minimum will be charged to cover the processing and inspection. Please consult the factory for your RMA number before returning any product repair.

TELEDYNE HASTINGS INSTRUMENTS
804 NEWCOMBE AVENUE
HAMPTON, VIRGINIA 23669 U.S.A.
ATTENTION: REPAIR DEPARTMENT

TELEPHONE (757) 723-6531
TOLL FREE 1-800-950-2468
FAX (757) 723-3925
E MAIL hastings_instruments@teledyne.com
INTERNET ADDRESS <http://www.teledyne-hi.com>

Repair Forms may be obtained from the "Information Request" section of the Hastings Instruments web site.

12. Diagrams and Drawings

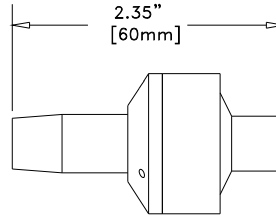
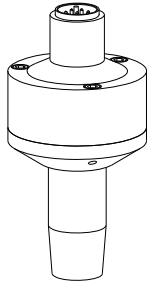

1/8" NPT (HPM-2002-01)

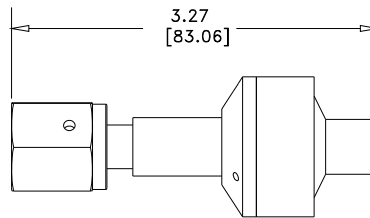
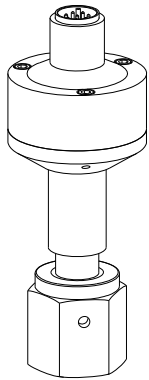

1/4" VCR (HPM-2002-02)

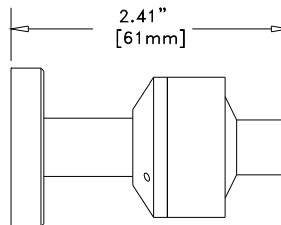
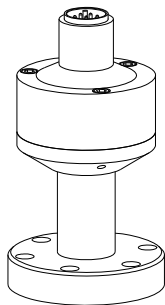

Mini Conflat™ (HPM-2002-03)

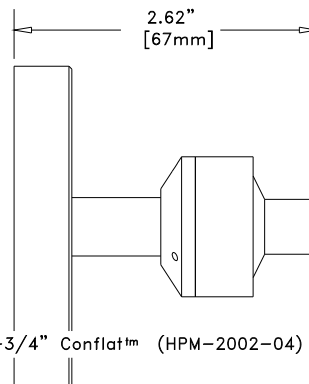
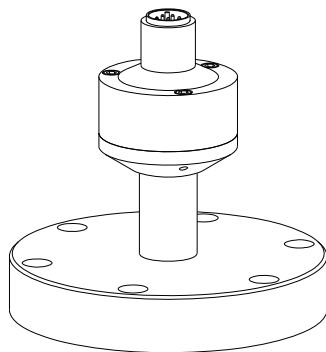

2-3/4" Conflat™ (HPM-2002-04)

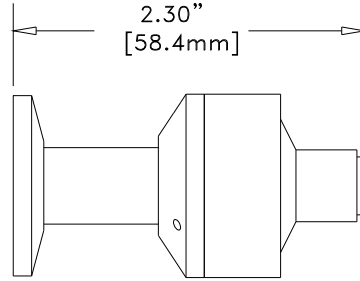
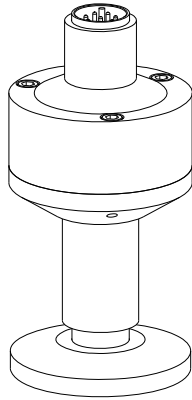

KF-16 (HPM-2002-05)

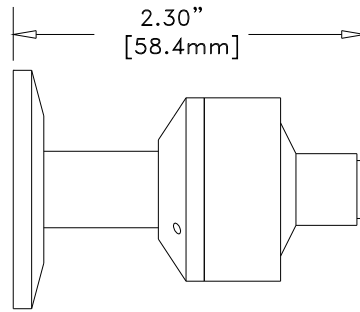
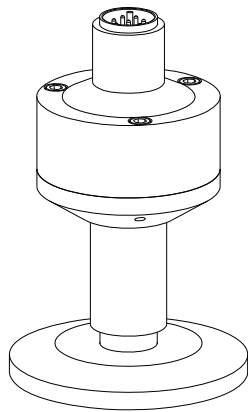

KF-25 (HPM-2002-06)

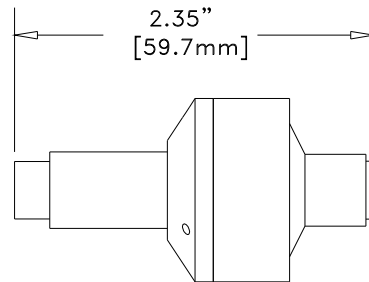
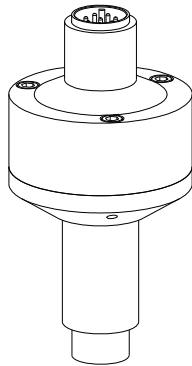

1/2" OD Smooth tube (HPM-2002-07)

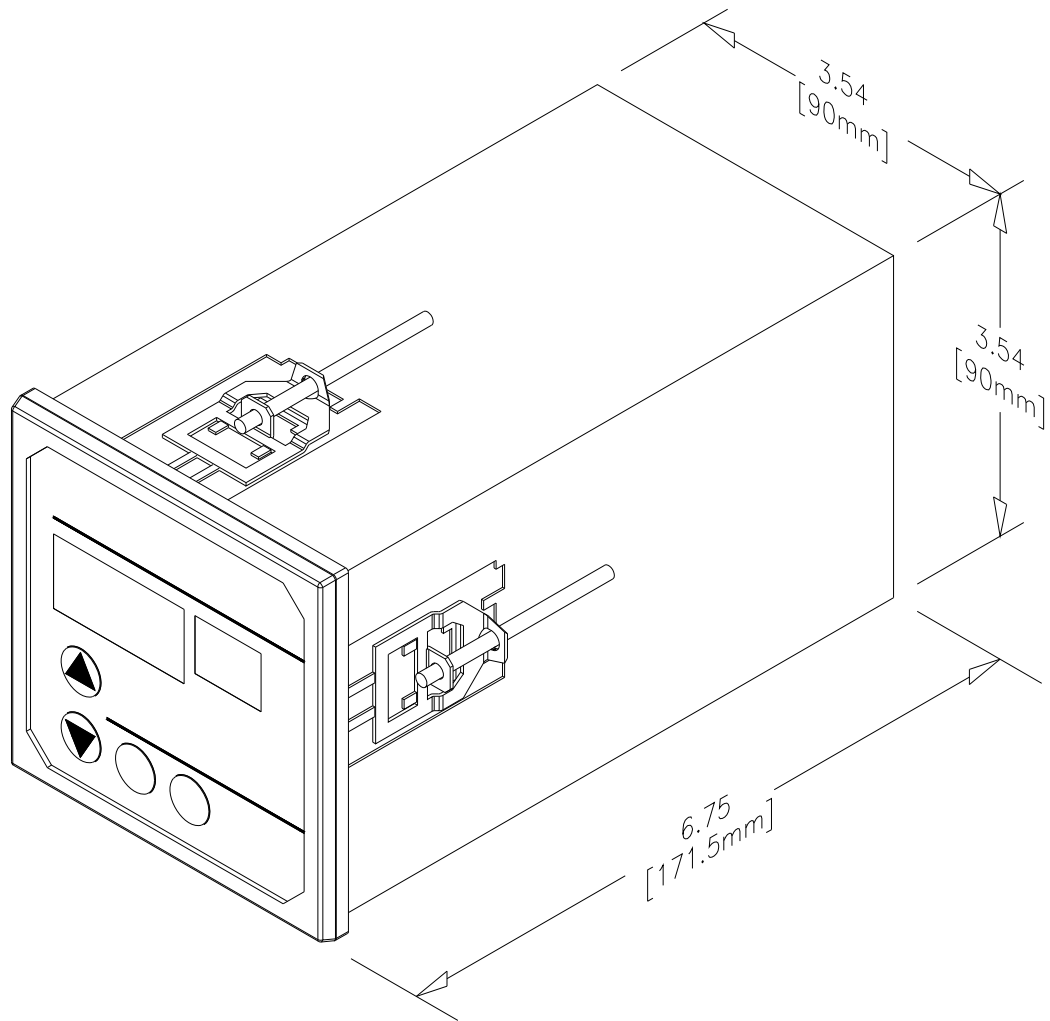

Model 2002
Outline Dimensions

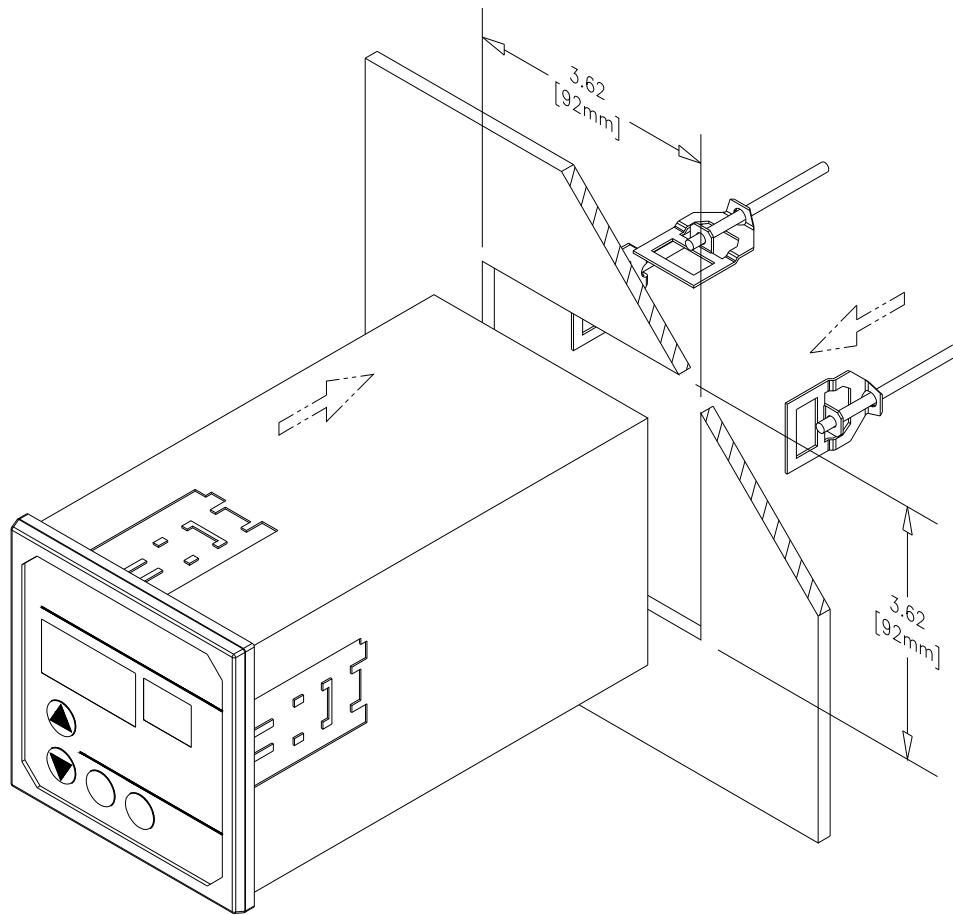

Panel Mounting
and Cut-Out Dimensions

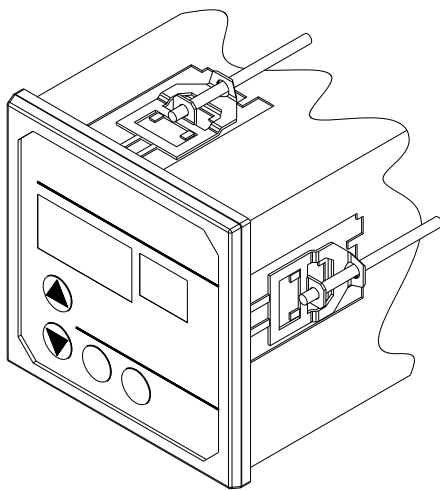

Deep Mounting
Location

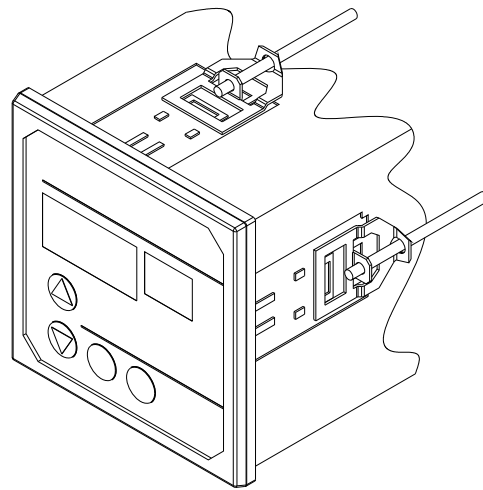

Shallow Mounting
Location