

# TELEDYNE HASTINGS INSTRUMENTS

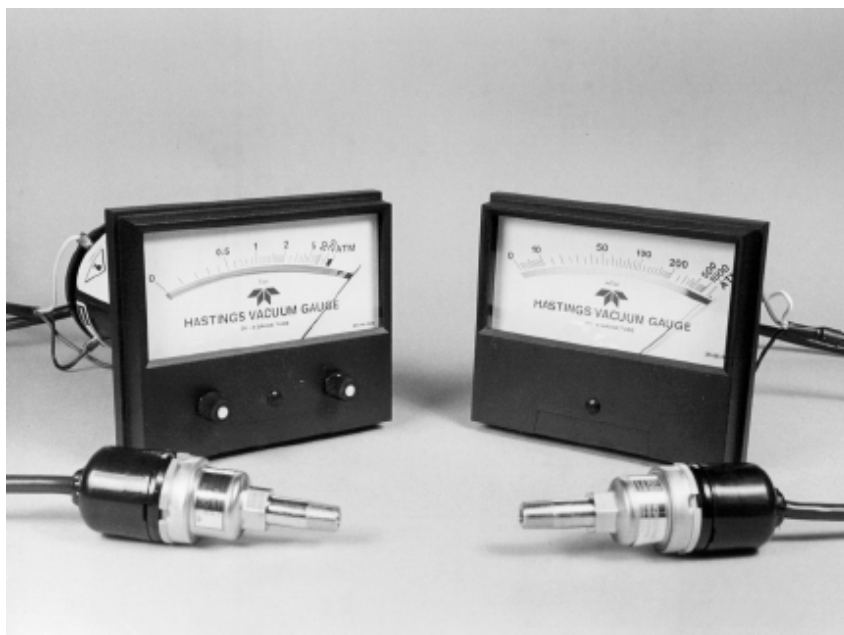

INSTRUCTION MANUAL

## VT/CVT SERIES VACUUM GAUGES and CONTROLLERS



**TELEDYNE**  
**HASTINGS INSTRUMENTS**  
A Teledyne Technologies Company

**ISO 9001**  
CERTIFIED

## Manual Print History

The print history shown below lists the printing dates of all revisions and addenda created for this manual. The revision level letter increases alphabetically as the manual undergoes subsequent updates. Addenda, which are released between revisions, contain important change information that the user should incorporate immediately into the manual. Addenda are numbered sequentially. When a new revision is created, all addenda associated with the previous revision of the manual are incorporated into the new revision of the manual. Each new revision includes a revised copy of this print history page.

Revision A (Document Number 146-0497) .....	April 1997
Revision B (Document Number 146-0999) .....	September 1999
Revision C (Document Number 146-0301) .....	March 2001
Revision D (Document Number 146-0902) .....	September 2002
Revision E (Document Number 146-0805) .....	August 2005
Revision F (Document Number 146-0710) .....	July 2010
Revision F (Document Number 146-1111) .....	November 2011



**Visit [www.teledyne-hi.com](http://www.teledyne-hi.com) for WEEE disposal guidance.**



**CAUTION:** The instruments described in this manual are available with multiple pin-outs. Ensure that all electrical connections are correct.



**CAUTION:** The instruments described in this manual are designed for INDOOR use only.



**CAUTION:** The instruments described in this manual are designed for Class 2 installations in accordance with IAW/IPC standards

---

Hastings Instruments reserves the right to change or modify the design of its equipment without any obligation to provide notification of change or intent to change.

---

# Table of Contents

1.1.	FEATURES .....	4
1.2.	SPECIFICATIONS .....	4
1.3.	SAFETY .....	4
1.4.	ACCESSORIES .....	5
1.5.	DV-6S: NEW DV-6 TUBE FOR SEVERE ENVIRONMENTS .....	5
1.6.	CALIBRATION REFERENCE TUBES .....	5
<b>2.0</b>	<b>INSTALLATION.....</b>	<b>6</b>
2.1.	PANEL MOUNT VACUUM GAUGE AND CONTROLLER .....	6
2.2.	CABINET MOUNT VACUUM GAUGE.....	7
2.3.	EXTERNAL CABLES AND WIRING.....	7
2.4.	VACUUM GAUGE TUBE .....	9
<b>3.0</b>	<b>VACUUM GAUGE OPERATION.....</b>	<b>10</b>
3.1.	METER MECHANICAL ZERO .....	10
3.2.	AC INPUT POWER.....	10
3.3.	PRESSURE MEASUREMENT .....	10
3.4.	CONTROLLER SET POINTS (CVT UNITS ONLY) .....	10
3.5.	OPERATION AND PERFORMANCE CHECK.....	10
3.6.	GAUGE TUBE OPERATION.....	11
3.7.	ANALOG PRESSURE MEASUREMENT .....	11
3.8.	CALIBRATION .....	13
3.8.1.	CALIBRATION USING A VACUUM SYSTEM .....	13
3.8.2.	CALIBRATION USING A HASTINGS REFERENCE TUBE.....	13
<b>4.0</b>	<b>WARRANTY.....</b>	<b>14</b>
4.1.	WARRANTY REPAIR POLICY .....	14
4.2.	NON-WARRANTY REPAIR POLICY.....	14

# 1.0 Installation

This manual contains technical and general information relating to the installation, operation, and calibration of Hastings Vacuum Gauges, Controllers, and Gauge Tubes.

For best performance, Hastings vacuum gauges should be operated with the appropriate Hastings gauge tube. Attempting to use a Hastings vacuum gauge with other manufacturer's tubes may result in damage to both the gauge and tube.

## 1.1. Features

Hastings vacuum gauges and controllers are self-contained instruments that offer extreme versatility for most vacuum applications. The electronic design assures long life and minimal maintenance. Compact VT & CVT Models are ready for mounting onto a panel.

Hastings vacuum gauges and controllers utilize Hastings rugged but sensitive gauge tubes which are designed specifically for each of the three available pressure ranges (consult Hastings Ordering and Dimension guide).

## 1.2. Specifications

Pressure range:

VT-4 series, CVT-14/24,.....0-20 Torr or 0-20 mbar

VT-5, CVT-15/25, ..... 0-100 mTorr or 0-0.1 mbar

VT-6series, CVT-16/26, ..... 0-1000 mTorr or 0-1 mbar

Input power ..... 115 or 230 VAC, 50/60 Hz

Output signal ..... 0-1 VDC (analog, non-linear)

Optional VT series

Standard CVT series

Control relays ..... 5A @ 250 VAC (resistive load)  
5A @ 30 VDC (resistive load)

Cables ..... 6 ft (1.8 m) power  
8 ft (2.4 m) gauge tube

Weight:

Panel mount meters .....1.78 lb (0.81 kg) w/cables

Panels mount controller's.....2.13 lb (0.97 kg) w/cables

Cabinet models .....4.25 lb (2.0 kg) w/cables

## 1.3. Safety

The following symbols and terms may be found on THI products and/or in THI manuals and indicate important information.



When found on the device, this symbol indicates that the operator should refer to the manual for important instructions on the proper use of this device. When found in a manual, this symbol indicates that the reader should understand the implications contained in the text before operating the device.

The WARNING label indicates important information that should be heeded for safe and proper performance of the device.

The label, CAUTION, is used to indicate that damage to the power supply or equipment connected to it, could occur if directions are not followed. Warranty could be invalidated if the instructions in this manual are not followed.

## 1.4. Accessories

THI offers a complete line of system attachments that permit easy maintenance for contaminated operations. Gauge tubes are offered with various system fittings to match almost any system requirement. Additionally, THI's complete line of quick disconnect attachments allows customers to install these special fittings and easily replace sensors without vacuum sealant or Teflon® tape. For particularly dirty systems, Hastings offers a particle dropout trap containing a series of nine separate baffles which prevent solid contaminants from having a direct path to the sensor's thermopile.

## 1.5. DV-6S: New DV-6 tube For Severe Environments

Hastings Instruments has developed a new gauge tube, the DV-6S, which is specifically designed for outdoor use on cryogenic tanks including railcar and tanker truck applications. In addition to the DAVC, the gauge tube is compatible with the hand-held HPM-4/6 and the analog VT-6.

The DV-6S is supplied with a protective cap. The o-ring-sealed cap protects the gauge tube pins from moisture thus significantly reducing corrosion. A metal

lanyard prevents cap loss. The tube is provided with a standard 1/8" NPT fitting; however special fitting requests can often be met.

## 1.6. Calibration Reference Tubes

THI Reference Tubes employ the same metal thermopiles used in all THI Vacuum Gauge Tubes. The thermopile is sealed in a glass capsule that has been evacuated, baked, out-gassed, and then aged to ensure long-term stability. The sealed capsule is then housed in a protective metal shell to provide a rugged, trouble-free assembly.

Once assembled, the reference gauge tube is accurately calibrated to precisely simulate a gauge tube at a given operating pressure. It provides quick and easy instrument re-calibration by merely plugging the instrument and adjusting the calibration potentiometer until the display reads the exact pressure noted on the reference tube.

### Extension Cables for VT Series

55-3	OM-8-OFV	8 Ft Extension Cable
55-22	OM-12-OFV	12 Ft Extension Cable
65-53	OM-25-OFV	25 Ft Extension Cable
65-102	OM-50-OFV	50 Ft Extension Cable
55-142	OM-100-OFV	100 Ft Extension Cable

### Vacuum Gauge Tubes 1000 mTorr Range

Stock #	Model #	Description
55-38	DV-6M	1/8" NPT Standard (Yellow base)
55-38R	DV-6R	1/8" Ruggedized
55-38RS	DV-6	1/8" NPT Rohs Rugged
55-38S	DV-6S	1/8" NPT Rugged/Vibration
55-251	DV-6-KF-16	KF-16™
55-267	DV-6-KF-25	KF-25™
55-283	DV-6-VCR	VCR™
55-38R-CF	DV-6R-CF	Mini Conflat™

### Vacuum Gauge Tubes 100 mTorr Range

55-19	DV-5M	1/8" NPT (Red Base)
55-230	DV-5M -VCR	VCR™

### Vacuum Gauge Tubes 20Torr Range

55-19	DV-4D	1/8" NPT (Purple Base)
55-19R	DV-4R	1/8" NPT Ruggedized
55-258	DV-4D-KF-16	KF-16™
55-266	DV-4D-KF-25	KF-25™
55-227	DV-4D-VCR	VCR™

### Reference Tubes for use with VT/CVT

55-104	DB-20	Ref Tube (DV-6) for DV-6 Calibration
55-101	DB-16D	Ref Tube (DV-4D) for DV-4 Calibration
55-103	DB-18	Ref Tube (DV-5) for DV-5 Calibration

# 2.0 Installation

## 2.1. Panel Mount Vacuum Gauge and Controller

Refer to figures 2.1 and 2.2 for outline dimensions of Hastings VT and CVT series units, to be used when considering mounting locations. Use dimensional drawing (figure 2.3) to cut-out and drill the gauge/controller mounting panel. Install gauge or controller onto panel using hardware supplied with your unit.

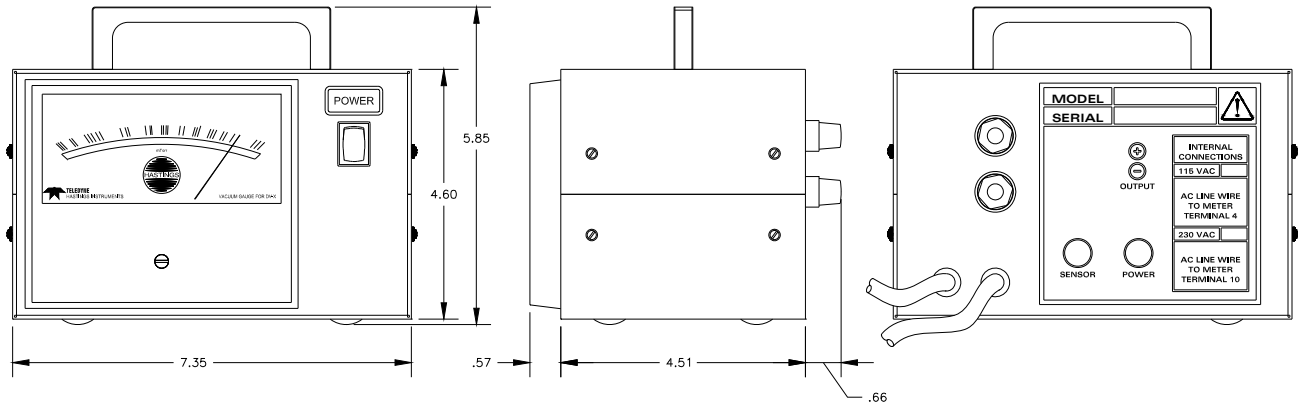

Fig 2.1  
VT Series

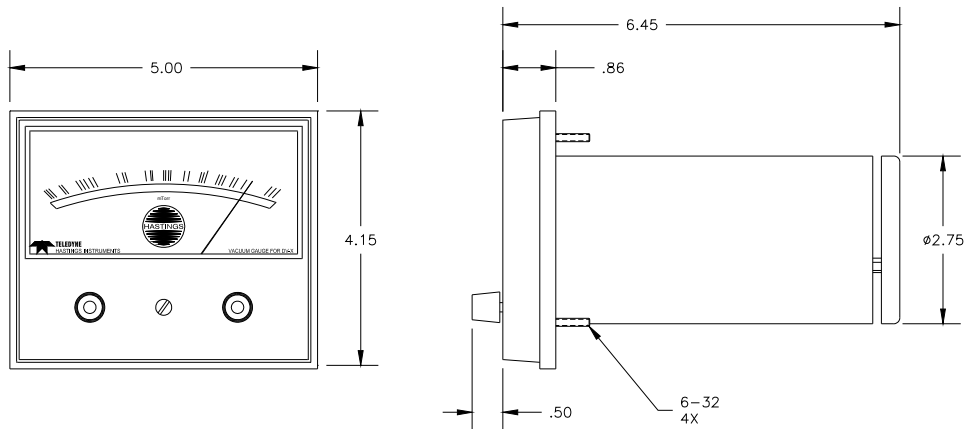
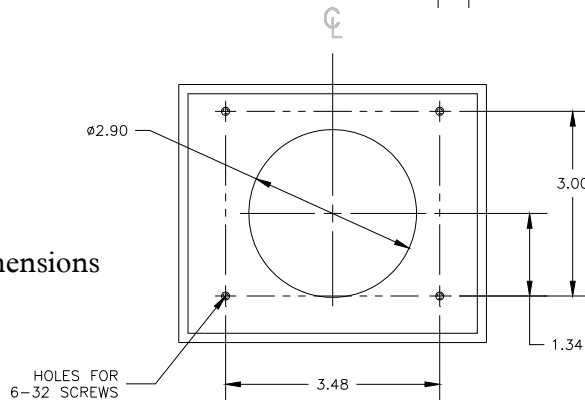

Fig 2.2  
CVT Series

### Mounting Dimensions



## 2.2. Cabinet Mount Vacuum Gauge

Hastings cabinet models can be obtained with 2 - position or 5 - position tube switching functions that will allow the user to display pressure from one or more selected tubes. No special installation is necessary; simply connect the power cord and the gauge tube cables.

**Note: All of the gauge tube cables on either a 2-position or a 5-position unit must be equal in length. Mixing cable lengths on a particular unit will produce a calibration error due to the different resistances of the cables.**

## 2.3. External Cables and Wiring

**WARNING: To prevent shock hazard to personnel, always install protective cover before application of AC power or prior to placing instrument in-service.**

VT series units

Connect the AC power cable, gauge tube cable, and analog output (analog output is only available on units configured from the factory with 0-1 VDC) as detailed in figure 2-4. The terminal block protective cover must be removed to access screw terminals.

Terminal	Function	Description
3	Gauge tube cable	Heated T.C. (blk wire)
4	AC power cable	115 VAC (blk wire)
5	Gauge tube cable	Heated T.C. (wht wire)
6	Gauge tube cable	Compensated T.C. (green wire)
7	Analog output (1vdc)	Negative analog output terminal
8	Analog output (1vdc)	Positive analog output terminal
9	AC power cable	Lo VAC (wht wire)
10	AC power cable	230 VAC (blk wire)
13	COM	chassis ground
14	COM	AC power ground (green/yellow wire)

### WARNING:

**When 115 VAC is connected to the auto transformer, 230 VAC appears at the 230 VAC terminal. The same occurs when you attach 230 VAC to the unit, 115 VAC appears at the 115 VAC terminal.**

Fig 2.4

VT Series Terminal Block

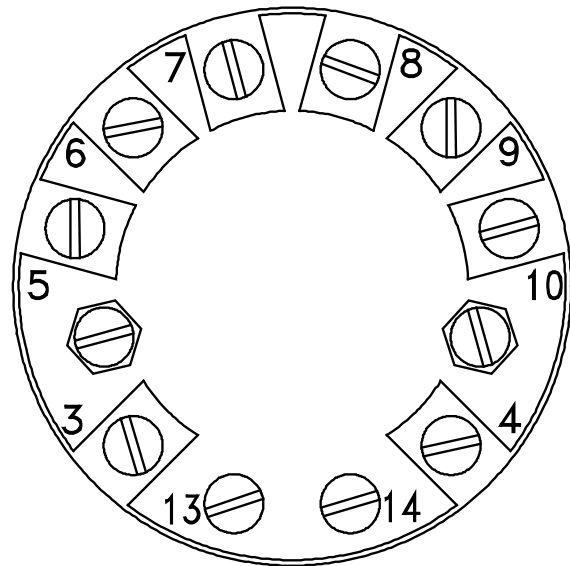

CVT series units

Connect the AC power cable, gauge tube cable, control relay and analog output (analog output is optional on VT and standard on CVT) as detailed in figure 2-5. The terminal block protective cover must be removed to access screw terminals.

TERMINAL FUNCTION DESCRIPTION

TERMINAL	FUNCTION	DESCRIPTION
1	Lo set relay	(Normally Closed) relay contact
2	Lo set relay	(Normally Open) relay contact
3	Gauge tube cable	Heated T.C. (blk wire)
4	AC power cable	115 VAC (blk wire)
5	Gauge tube cable	Heated T.C. (wht wire)
6	Gauge tube cable	Compensated T.C. (green wire)
7	Analog output (1vdc)	negative analog output terminal
8	Analog output (1vdc)	positive analog output terminal
9	AC power cable	Lo VAC (wht WIRE)
10	AC power cable	230 VAC (blk WIRE)
11	Spare	no connection
12	Lo set relay	(COM) relay contact
13	COM	chassis ground
14	COM	AC power ground (green/yellow wire)
15	Hi set relay	(Normally Closed) relay contact
16	Hi set relay	(Normally Open) relay contact
17	Hi set relay	(COM) relay contact

Fig 2.5  
CVT Series  
Terminal Block

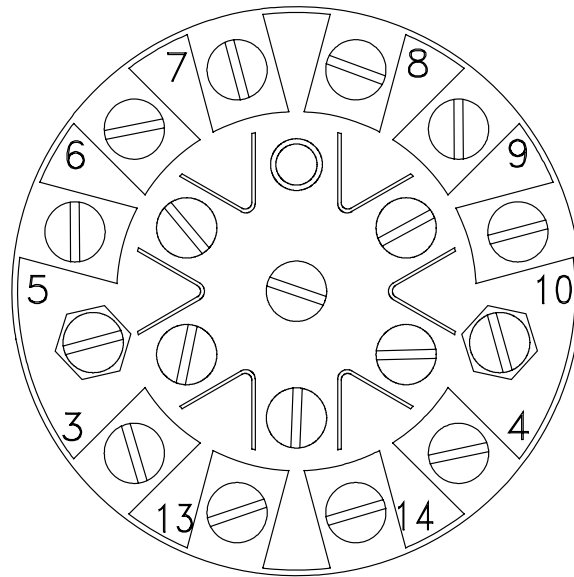

**WARNING:**

**When 115 VAC is connected to the auto transformer, 230 VAC appears at the 230 VAC terminal. The same occurs when you attach 230 VAC to the unit, 115 VAC appears at the 115 VAC terminal.**



## 2.4. Vacuum Gauge Tube

All Hastings gauge tubes are shipped with a protective cap or cover at the evacuation port to reduce contamination and prevent physical damage to the internal thermopile elements. Once the protective cap or cover is removed, a tube can be installed in any convenient position in the vacuum system without adversely affecting calibration or performance. The recommended orientation is with the tube vertical and its stem down. This will aide in preventing condensable materials from remaining in the gauge tube.

Hastings instruments also offer a wide variety of installation accessories for use with your vacuum gauge tube. Please consult the Hastings Ordering and Dimension Guide or contact your factory representative for information on these products.

**WARNING: Compression seal fittings “Quick-Connects” are not for use in systems where the tube can be pressurized above atmosphere.**

# 3.0 Vacuum Gauge Operation

## 3.1. Meter Mechanical Zero

With the gauge in its normal operating position (AC power removed), check that the meter pointer covers the Dot at right-end of the dial face. If the Dot is not covered by the pointer, adjust screw at the front of the meter until the pointer covers the Dot.

## 3.2. AC Input Power

Connect the plug end of power cable into a single phase 115 or 230 V, 50/60 Hz power source (as per unit configuration). When replacing the power cords standard plug with a plug to match a particular system, care should be taken to connect the new plug in accordance with the terminal block connections listed in section 2.4 of this manual.

## 3.3. Pressure Measurement

Connect gauge tube cables octal socket onto the octal base of a gauge tube installed in vacuum system. The gauge will display the system pressure on the meter dial face. To check the accuracy of the gauge, perform the required operations as specified in section 3.5 of this manual.

## 3.4. Controller Set Points (CVT units only)

The CVT series vacuum controllers are provided with either single or double set points. On a single set point controller, the right-front panel knob allows the user to adjust or position the “RED” pointer on the dial face where a desired control function will occur.

On the double set point controller, the left-front panel knob is added to allow the user to adjust or position a second “RED” pointer on the dial face where a desired control function will occur.

On those controllers configured with two front panel knobs; the left knob controls the LO Set pressure (Relay K1), and the right knob controls the HI Set pressure (Relay K2).

Control logic determines that a relay will (energize) when the indicated pressure is lower than the set-pressure, and de-energize when the indicated pressure is higher than the set-pressure or if there is a loss of AC power to the unit.



**CAUTION:** To avoid relay chatter, keep the lower set point above the ultimate system pressure

## 3.5. Operation and Performance Check

All Hastings vacuum gauges, controllers, and tubes have been carefully calibrated and checked at the factory before shipment. When an operational check or calibration is desired, refer to the procedure outlined in this section.

The simplest and quickest way of checking the operation and performance of a gauge and/or gauge tube is to maintain a new or known-good gauge tube on hand for use as a Reference. To check operation, install both the Reference and suspect gauge tubes in a common vacuum

system (locate the gauge tubes as close as possible to each other), then evacuate the system until a stable base pressure is obtained. Alternately connect the vacuum gauge to each gauge tube and record its pressure readings. If the gauge tube-under-test produces a higher pressure reading than the Reference gauge tube, this indicates a calibration shift and is usually the result of contamination (particulate, oil, or other chemical deposits). You can try to restore calibration of the contaminated gauge tube by cleaning it internally with an appropriate solvent such as high-purity isopropyl alcohol (flood interior cavity of gauge tube gently with solvent and allow it to stand and soak for about 15 to 30-minutes). Drain the contaminated solvent and let gauge tube dry in ambient air until all of the cleaning solvent has evaporated. To prevent mechanical damage to the thermopile elements, do not use forced air to dry the gauge tube. Gauge tubes that remain out of calibration after cleaning should be replaced.

### 3.6. Gauge Tube Operation

Operation of the Hastings gauge tube is based on a low voltage AC bridge that heats a noble metal thermopile. A change in pressure in the gauge tube changes the molecular collision rate and therefore the thermal conduction of the gas or gas mixture surrounding the thermopile. This results in a temperature shift in the AC heated thermocouples A and B (Fig. 3.1). The resultant temperature shift causes a change in the DC output from couples A and B inversely with pressure changes. The DC thermocouple C (when installed) is in series with the circuit load. Thermocouple C provides compensation for transient changes in ambient temperature.

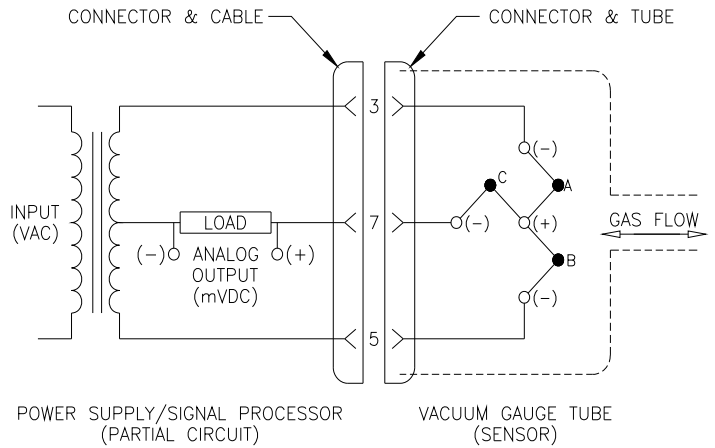

Fig 3.1

### 3.7. Analog Pressure Measurement

An analog Signal Output line, pin 8, supplies a 0 to 1 VDC signal corresponding to the output range of the selected tube. This signal should be measured with respect to the analog Signal Common line, pin 7. See the INSTALLATION section for a diagram showing the Analog Signal pin out.

This signal is equal to an amplified tube millivolt signal. This signal will NOT be linearly proportional to the indicated pressure. 1 volt will correspond to a system pressure that is at least 1 order of magnitude less than the minimum detectable pressure. Increasing pressure will be indicated by a decreasing voltage. The minimum detectable pressure is 0.2 millitorr for DV-5, 1 millitorr for DV-6 and 20 millitorr for DV-4.

Parameters	DV6	DV4	DV5
a	-1623.22	-5.10184	-0.25948
b	-58.0442	-6.91233	-42.23869
c	-11732.2	-4.4943	-2.92598
d	-130.397	-6.30995	-256.9951
e	13338.17	9.563177	3.18016

The voltage signal can be mapped to a pressure value by using the following equation.

Where: 
$$P = \frac{a + cV + eV^2}{1 + bV + dV^2}$$

V = Voltage

P = pressure in Torr for DV4 & DV5 versions and millitorr for DV6

See Chart below

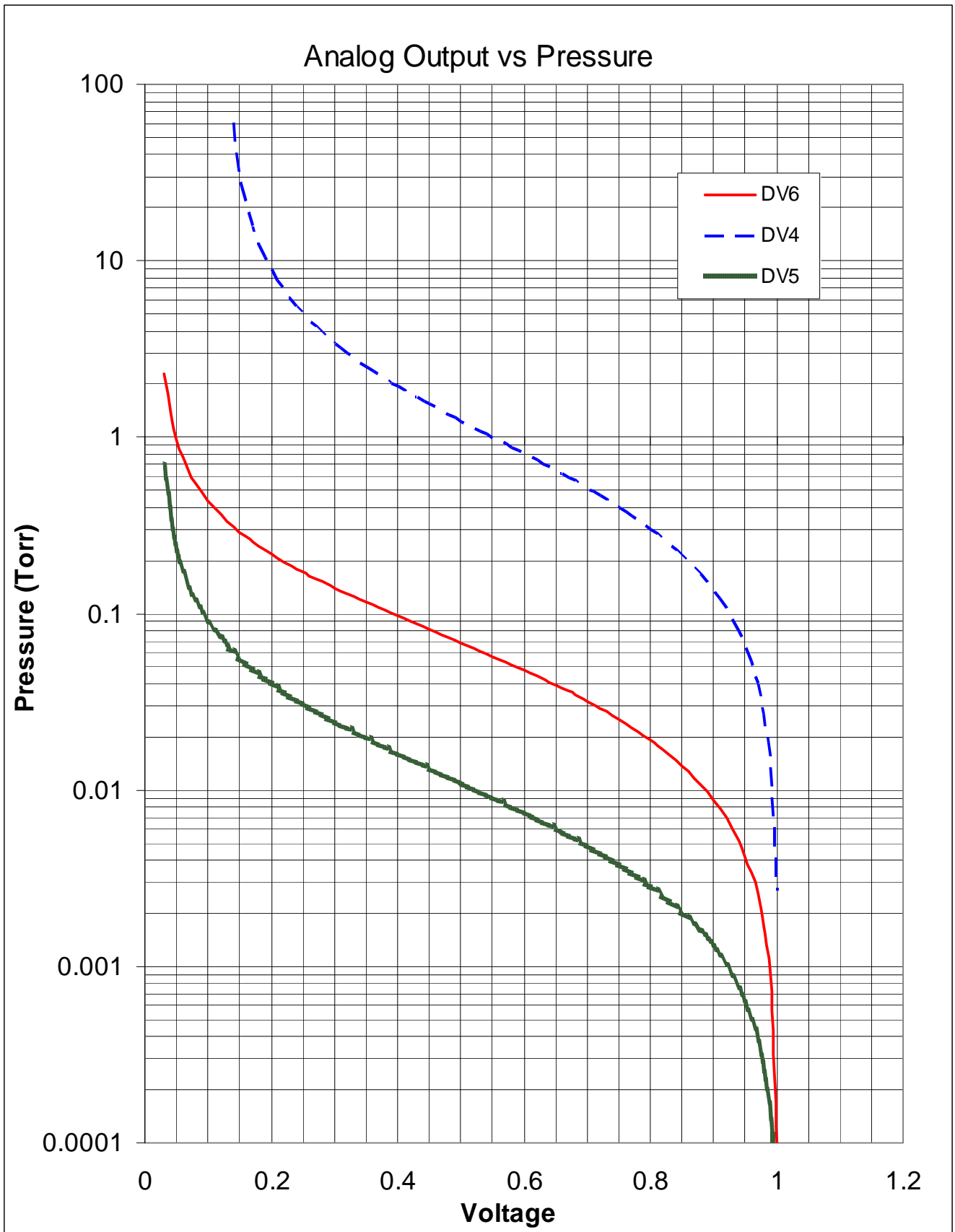

### 3.8. Calibration

Using a vacuum system to calibrate a gauge or gauge/tube combination will result in a more accurate pressure measurement. For instances where this is not possible, calibrating the gauge using a Hastings reference tube provides the best alternative.

**NOTE: For cabinet models, the top-cover must be removed to access the CAL control.**

#### 3.8.1. Calibration Using A Vacuum System

Install the gauge tube in a vacuum system (gauge connected to AC power and stabilized), then evacuate to a pressure one decade or more below the gauge dial face resolution. Connect the gauge to tube and wait until the displayed pressure is stable.

**NOTE: When using a DV-4 type gauge tube, system pressure must be less than  $1.0 \times 10^{-2}$  Torr.**

**When using DV-5 or DV-6 type gauge tubes, system pressure must be less than  $1.0 \times 10^{-5}$  Torr.**

Adjust the gauge CAL. adjustment (figure 3.2) until the meter pointer indicates zero-left on the dial face.

#### 3.8.2. Calibration Using A Hastings Reference Tube

Connect a Hastings reference tube to a stabilized vacuum gauge. Wait until the displayed pressure is stable.

**NOTE: The following table specifies the Hastings reference tube to be used in the calibration of a gauge based upon the type of gauge tube being used:**

<u>Reference tube</u>	<u>Gauge tube</u>
DB-16D	DV-4
DB-18	DV-5
DB-20	DV-6

Adjust the gauge CAL control (figure 3.2) until the meter pointer indicates the pressure specified on the decal of the reference tube in use.

Fig 3.2  
calibration points

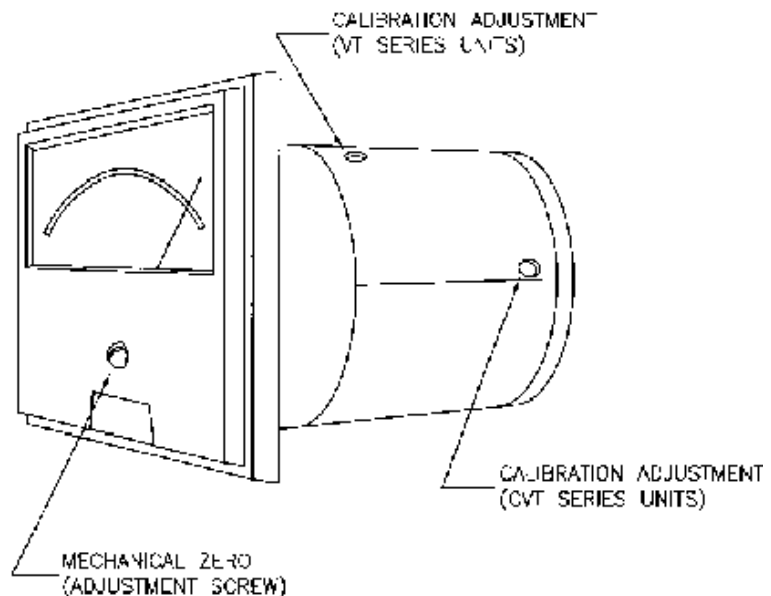

# 4.0 Warranty

## 4.1. Warranty Repair Policy

Hastings Instruments warrants this product for a period of one year from the date of shipment to be free from defects in material and workmanship. This warranty does not apply to defects or failures resulting from unauthorized modification, misuse or mishandling of the product. This warranty does not apply to batteries or other expendable parts, nor to damage caused by leaking batteries or any similar occurrence. This warranty does not apply to any instrument which has had a tamper seal removed or broken.

This warranty is in lieu of all other warranties, expressed or implied, including any implied warranty as to fitness for a particular use. Hastings Instruments shall not be liable for any indirect or consequential damages.

Hastings Instruments, will, at its option, repair, replace or refund the selling price of the product if Hastings Instruments determines, in good faith, that it is defective in materials or workmanship during the warranty period. Defective instruments should be returned to Hastings Instruments, **shipment prepaid**, together with a written statement of the problem and a Return Material Authorization (RMA) number. Please consult the factory for your RMA number before returning any product for repair. Collect freight will not be accepted.

## 4.2. Non-Warranty Repair Policy

Any product returned for a non-warranty repair must be accompanied by a purchase order, RMA form and a written description of the problem with the instrument. If the repair cost is higher, you will be contacted for authorization before we proceed with any repairs. If you then choose not to have the product repaired, a minimum will be charged to cover the processing and inspection. Please consult the factory for your RMA number before returning any product repair.

TELEDYNE HASTINGS INSTRUMENTS  
804 NEWCOMBE AVENUE  
HAMPTON, VIRGINIA 23669 U.S.A.  
ATTENTION: REPAIR DEPARTMENT  
TELEPHONE (757) 723-6531  
1-800-950-2468  
FAX (757) 723-3925  
E MAIL [mailto:hastings\\_instruments@teledyne.com](mailto:hastings_instruments@teledyne.com)  
INTERNET ADDRESS <http://www.teledyne-hi.com>

Repair Forms may be obtained from the “Information Request” section of the Hastings Instruments