

TELEDYNE HASTINGS INSTRUMENTS



INSTRUCTION MANUAL

DIGITAL VT



Manual Print History

The print history shown below lists the printing dates of all revisions and addenda created for this manual. The revision level letter increases alphabetically as the manual undergoes subsequent updates. Addenda, which are released between revisions, contain important change information that the user should incorporate immediately into the manual. Addenda are numbered sequentially. When a new revision is created, all addenda associated with the previous revision of the manual are incorporated into the new revision of the manual. Each new revision includes a revised copy of this print history page.

Revision B (Document Number 162-062005)	June 2005
Revision C (Document Number 162-082005)	August 2005
Revision D (Document Number 162-112005)	November 2005
Revision E (Document Number 162-092007)	September 2007
Revision F (Document Number 162-072009)	July 2009
Revision G (Document Number 162-082010)	August 2010
Revision H (Document Number 162-072012)	July 2012



Visit www.teledyne-hi.com for WEEE disposal guidance.



CAUTION: The instruments described in this manual are designed for INDOOR use only.



CAUTION: The instruments described in this manual are designed for Class 2 installations in accordance with IPC standards

Hastings Instruments reserves the right to change or modify the design of its equipment without any obligation to provide notification of change or intent to change.

Table of Contents

1. GENERAL INFORMATION.....	4
1.1 FEATURES.....	4
1.2 SPECIFICATIONS	4
1.3 SAFETY.....	5
1.4 ACCESSORIES	5
1.4.1 INSTALLATION ACCESSORIES	5
1.4.2 DV-6S: NEW DV-6 TUBE FOR SEVERE ENVIRONMENTS	5
1.4.3 CALIBRATION REFERENCE TUBES	6
2. INSTALLATION	7
2.1 DIGITAL VT, OUTLINE DIMENSIONS.....	7
2.2 DIGITAL VT, FRONT PANEL.....	7
2.3 DIGITAL VT, BACK PANEL	8
2.4 MOUNTING LAYOUT	8
3. VACUUM GAUGE OPERATION	9
3.1 AC INPUT POWER.....	9
3.2 QUICK START	9
3.3 PRESSURE MEASUREMENT	9
3.4 OPERATION AND PERFORMANCE	9
3.5 TUBE SELECTION	10
3.6 GAUGE TUBE OPERATING PRINCIPLE	10
3.7 CALIBRATION PROCEDURE.....	10
3.7.1 PREPARATION.....	11
3.7.2 SET HIGH END.....	11
3.7.3 SET LOW END W/VACUUM SYSTEM.....	11
3.7.4 SET LOW END W/REFERENCE TUBE.....	11
4. WARRANTY AND REPAIR	12
4.1 WARRANTY REPAIR POLICY	12
4.2 NON-WARRANTY REPAIR POLICY	12

1. General Information

This manual contains technical and general information relating to the installation, operation, and calibration of Hastings Vacuum Gauges, and Gauge Tubes.

For best performance, Hastings vacuum gauges should be operated with the appropriate Hastings gauge tube. Attempting to use a Hastings vacuum gauge with other manufacturer's tubes may result in damage to both the gauge and tube.

1.1 Features

The Hastings Instrument's Digital VT, is a digital readout version of the successful VT-Series "Hastings Gauge" which has generated loyal customers for over 50 years. A reputation has been built on exceptional stability, accuracy, and reliability under the most demanding conditions.

A precision A/D converter, with a microprocessor is used to measure the gauge tube's signal output; it converts the measurement to a pressure reading using the gauge tube's well defined output/pressure function, and then display the result.

The Digital VT Vacuum Gauge Meter is available for two Hastings Instruments most popular gauge tube families: The DV-6 and DV-4. The DV-6 range is 0-1000 mTorr. The DV-4 range is 0-20 Torr. All VT-Series Vacuum Gauges feature long life and minimal maintenance.

These instruments utilize Hastings rugged noble metal TC gauge tubes that are designed specifically for each range.

Tubes are matched and interchangeable without calibration adjustments. They are compensated for temperature, rate of temperature change and are corrosion resistant.

1.2 Specifications

DIGITAL VT VACUUM METER:

INPUT POWER..... 4.5-5.3 volts DC, 155 ma
.....W/ INCLUDED POWER CONVERTER 90-240 VAC, 47-63 HZ, 2 WATTS
CABLES (Approx.) 6-ft. power cable and 8-ft. sensor cable included
WEIGHT (Approx.) 1 lb
OPERATING TEMPERATURE RANGE 5°C to 50°C

STANDARD METAL GAUGE TUBE (DV-6R, DV-4R):

OVERPRESSURE 50 psig max.
MATERIAL OF CONSTRUCTION Nickel-Plated steel, Stainless Steel,
.....Glass, Noble Metal, Thermocouples.
CONNECTIONS 1/8-in. NPT male thread
TUBE LEAK TEST 10⁻⁸ SCCS
GLASS Available for high temperature bakeable systems
..... 3/8 in. O. D. (10mm) smooth tabulation
VCR & KF CONNECTIONS VCR® female connection. 9/16-18 UNF, female threads
.....w/0.75 hex, Cajon No. SS-4 VCR-3 and No. SS-4-VCR 1.

CE Standard Compliance	
Test	Standard
SAFETY	EN61010
EMC/EMI Family	EN61326
CONDUCTED/RADIATED	EN55011
ESD	EN61000-4-2
RF	EN61000-4-3
FAST TRANSIENTS	EN61000-4-4
SURGE	EN61000-4-5
CONDUCTED IMMUNITY	EN61000-4-6
VOLTAGE DIPS	EN61000-4-11

1.3 Safety

The following symbols and terms may be found on THI products and/or in THI manuals and indicate important information.



When found on the device, this symbol indicates that the operator should refer to the manual for important instructions on the proper use of this device. When found in a manual, this symbol indicates that the reader should understand the implications contained in the text before operating the device.

The WARNING label indicates important information that should be heeded for safe and proper performance of the device.

The label, CAUTION, is used to indicate that the damage to the power supply or equipment connected to it, could occur if directions are not followed. Warranty could be invalidated if the instructions in this manual are not followed.

1.4 Accessories

1.4.1 Installation Accessories

Hastings Instruments offers a complete line of system attachments that permit easy maintenance for contaminated operations. Gauge tubes are offered with various system fittings to match almost any system requirement. Additionally, Hastings' complete line of quick disconnect attachments allows customers to install these special fittings and easily replace sensors without vacuum sealant or Teflon® tape. For particularly dirty systems, Hastings offers a particle dropout trap containing a series of nine separate baffles which prevent solid contaminants from having a direct path to the sensor's thermopile.

1.4.2 DV-6S: New DV-6 tube For Severe Environments

Hastings Instruments has developed a new gauge tube (DV-6S) which is specifically designed for outdoor use on cryogenic tanks including railcar and tanker truck applications. In addition to the Digital VT, the gauge tube is compatible with the hand-held HPM-4/6 and the analog VT-6.

The DV-6S is supplied with a protective cap. The o-ring-sealed cap protects the gauge tube pins from moisture thus significantly reducing corrosion. A metal lanyard prevents cap loss. The tube is provided with a standard 1/8" NPT fitting; however special fitting requests can often be met.

1.4.3 Calibration Reference Tubes

Hastings Instruments Reference Tubes employ the same Hastings metal thermopiles used in all Hastings Vacuum Gauge Tubes. The thermopile is sealed in a glass capsule that has been evacuated, baked, outgassed, and then aged to ensure long-term stability. The sealed capsule is then housed in a protective metal shell to provide a rugged, trouble-free assembly.

Once assembled, the reference gauge tube is accurately calibrated to precisely simulate a gauge tube at a given operating pressure. It provides quick and easy instrument re-calibration by merely plugging the instrument and adjusting the zero potentiometer until the display reads the exact pressure noted on the reference tube.

2. Installation

2.1 DIGITAL VT, OUTLINE DIMENSIONS

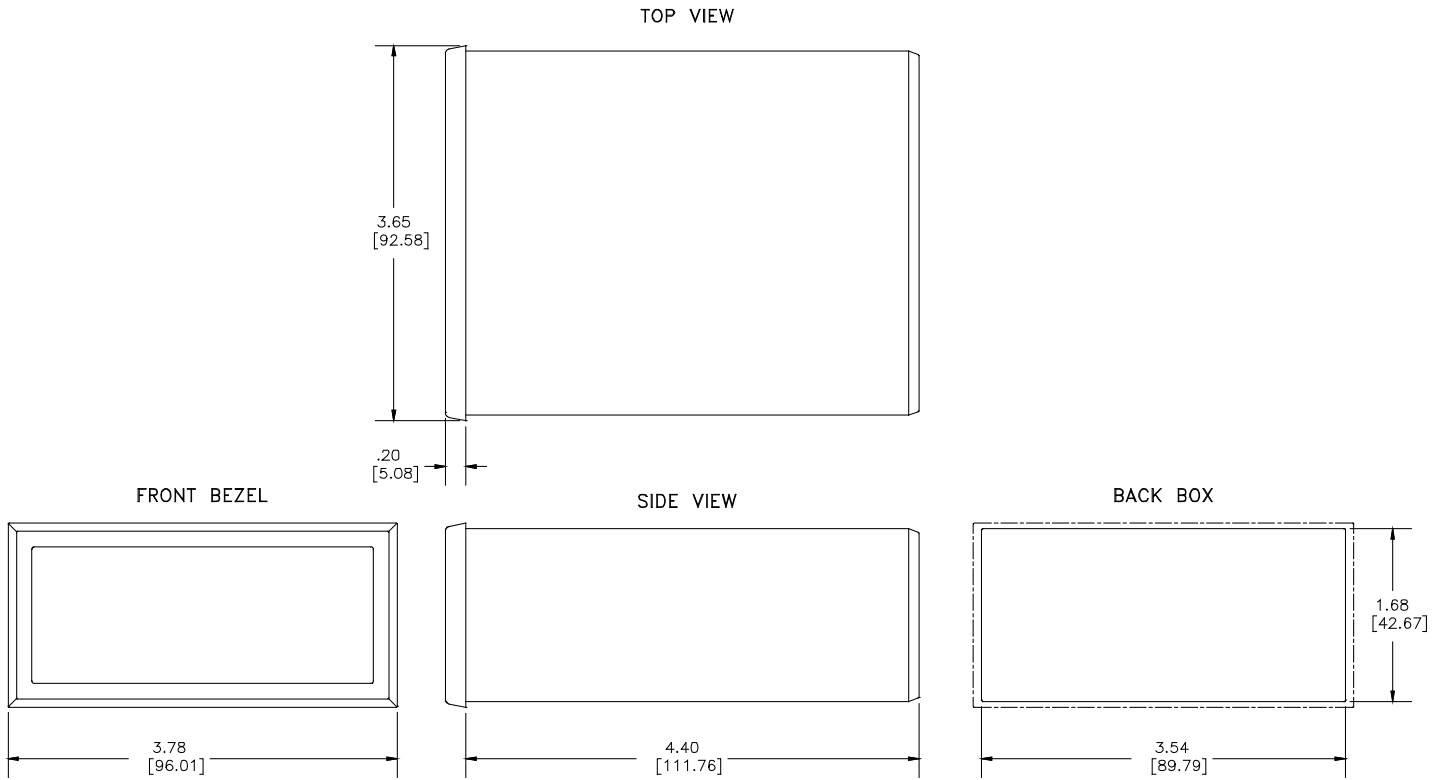

2.2 DIGITAL VT, FRONT PANEL

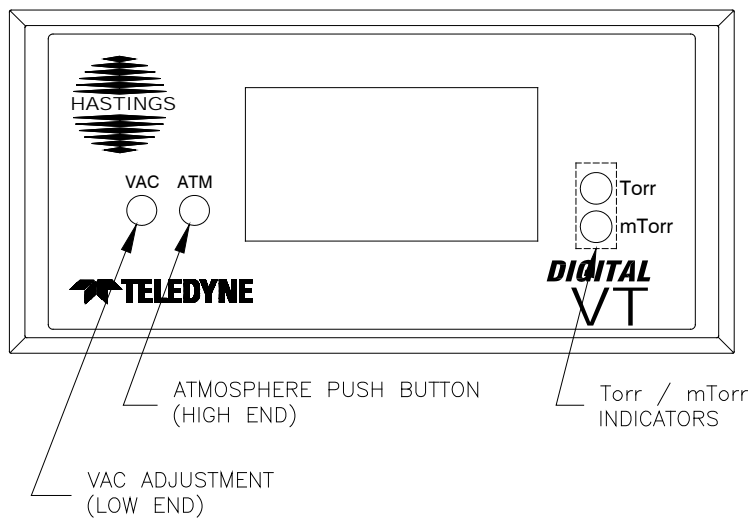

2.3 DIGITAL VT, BACK PANEL

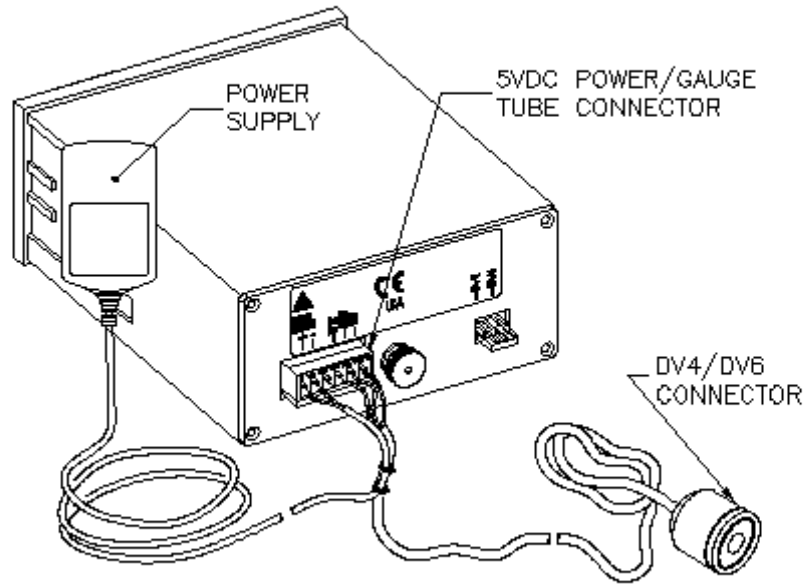

2.4 MOUNTING LAYOUT

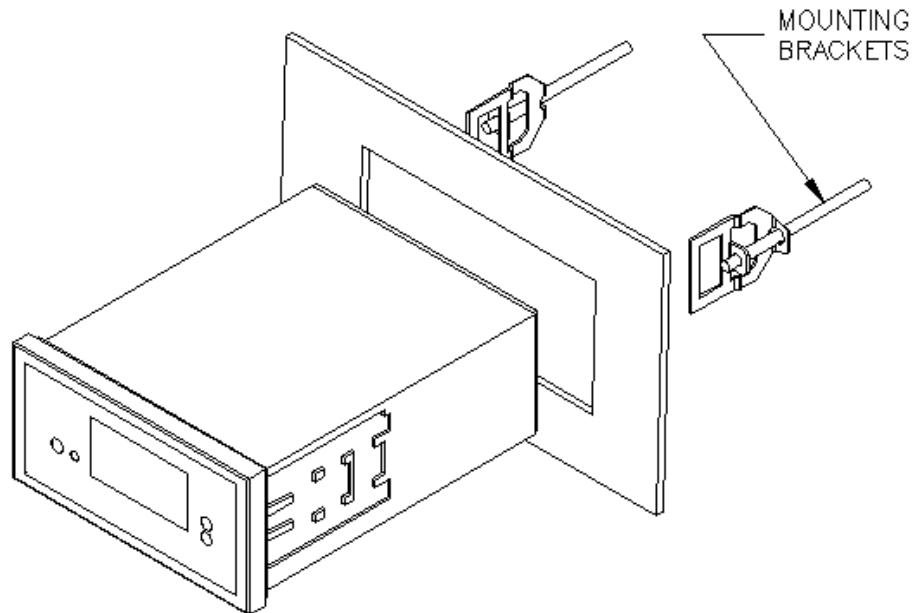

3. Vacuum Gauge Operation

All Hastings gauge tubes are shipped with a protective cap or cover at the evacuation port to reduce contamination and prevent damage to the internal thermopile elements. Once the protective cap or cover is removed, a tube can be installed in any convenient position in the vacuum system without adversely affecting calibration or performance. The recommended orientation is with the tube vertical and its stem down. This will aid in preventing condensable materials from remaining in the gauge tube.

3.1 AC Input Power

The Digital VT Power Supply input is rated as consuming 0.25 Amps @ 120VAC.



The Power/Gauge Tube Cable is assembled at the factory as shown in Fig. 4. It requires no further wiring to be performed. To operate the Digital VT, plug the Power/Gauge Tube Cable into the connector located in the rear of the Digital VT. Connect the plug of the power supply into a single phase 100-230 VAC, 50/60 Hz power source

3.2 Quick Start

1. Plug Digital VT power supply into a 100-230 Hz outlet source.
2. Connect a DV4 or DV6 gauge tube to the Octal Socket cable assembly that is attached to the rear of the Digital VT.
3. The CPU will do a self check/initialization. The digital display should count up and stop momentarily at FFF. (Note: If the digital display shows a "- -", this means the instrument is out of range or gauge tube is unplugged.)
4. The Torr and mTorr LED's should also momentarily illuminate.
5. After the CPU is operating, and the self check/initialization is complete, the display will indicate the output of the DV4 or DV6 tube.
6. No other operator action is required.
7. For a more accurate reading from the DV4 or DV6 tubes, refer to Section 3.7 and perform a calibration of unit.

3.3 Pressure Measurement

Connect the gauge tube cable's octal socket onto the octal base of a gauge tube installed in vacuum system. The gauge will display the system pressure on the Digital VT. To check the accuracy of the gauge, perform the required operations as specified in section 3.7.

3.4 Operation and Performance

The Digital VT will function right "out of the box". For maximum accuracy refer to section 3.7 and perform the calibration procedure.

The simplest and quickest way of checking the operation and performance of a gauge and/or gauge tube, is to keep in hand a new or known-good gauge tube on hand for use as a Reference.

To check operation, install both the Reference and suspect gauge tubes in a common vacuum system (locate the gauge tubes as close as possible to each other), then evacuate the system until a stable base pressure is obtained. Alternately connect the vacuum gauge to each gauge tube and record its pressure readings. If the gauge tube-under-test produces a higher pressure reading than the Reference gauge tube, this indicates a calibration shift and is usually the result of contamination (particulate, oil, or other chemical deposits). You can try to restore calibration of the contaminated gauge tube by cleaning it internally with an appropriate solvent such as high-purity isopropyl alcohol (flood the interior cavity of gauge tube gently with solvent and

allow it to stand and soak for about 15 to 30-minutes). Drain the contaminated solvent and let gauge tube dry in ambient air until all of the cleaning solvent has evaporated. To prevent mechanical damage to the thermopile elements, do not use forced air to dry the gauge tube. Gauge tubes that remain out of calibration after cleaning should be replaced.

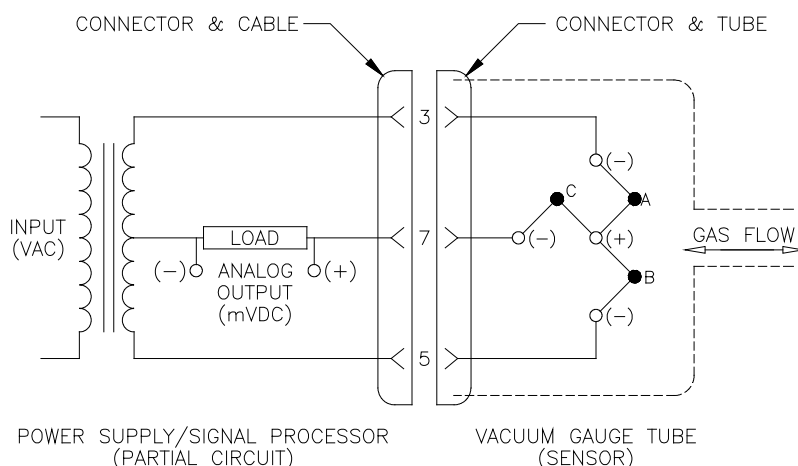

3.5 TUBE SELECTION

The Digital VT can be setup to operate with a Hastings DV4 or DV6 vacuum gauge tube. There is a jumper located on the rear panel which will select the desired tube. Normally the Digital VT will arrive from the factory configured for the tube type specified by the customer order. However if the system pressure range changes, and a different tube type will now be used, the tube type can be changed by moving the jumper position. Position the jumper over the leftmost two pins for DV-4 tubes and over the rightmost two pins for DV-6 tubes. It is recommended that the tube calibration procedure in section 3.7 be performed after changing the tube type.

Note: Complete removal of the jumper will be interpreted by the internal processor as the DV6 configuration

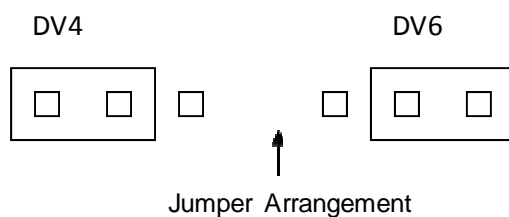

3.6 Gauge Tube Operating Principle

Operation of the Hastings gauge tube is based on a low voltage AC bridge that heats a noble metal thermopile. A change in pressure in the gauge tube changes the molecular collision rate and therefore the thermal conduction of the gas or gas mixture surrounding the thermopile. This results in a temperature shift in the AC heated thermocouples A and B (Fig. 6). The resultant temperature shift causes a change in the DC output from couples A and B inversely with pressure changes. The DC thermocouple C (when installed) is in series with the circuit load. Thermocouple C provides compensation for transient changes in ambient temperature.

3.7 Calibration Procedure

NOTE: ONCE CALIBRATION IS COMPLETE THE CALIBRATION DATA IS PERMANENTLY STORED IN NONVOLATILE MEMORY. A LOSS OF POWER WILL NOT ERASE THE CALIBRATION DATA. TO ERASE THE CALIBRATION DATA, REFER TO STEP 2.

3.7.1 Preparation

1. Plug the Digital VT power supply into an outlet providing 100-230 VAC, 50/60 Hz.
2. CLEAR out any previously entered calibration data.
 - a. Using a pointed object, such as a ballpoint pen, press and hold the “ATM” push button located on the front panel until “CLR” appears on the digital display. The “ATM” button must be held in the pressed position approximately 5 seconds before data is cleared and “CLR” is displayed.
5. Once “CLR” is displayed any previously entered data has been deleted.
6. Plug in DV-4 or DV-6 gage tube. Leave tube at atmospheric pressure.

NOTE: TUBE MUST BE AT ATMOSPHERE TO PROPERLY SET THE HIGH END.

3.7.2 Set High End

- A. Press “ATM” push button until “Set” appears. The high-end setting is now set.

NOTE: The LOW END can be adjusted by either bringing the system to a known vacuum or by using a HASTINGS REFERENCE TUBE.

3.7.3 Set Low End W/Vacuum System

- A. Set system to known vacuum.
- B. Turn the “VAC” pot on front panel until the known vacuum is displayed on digital display. (For DV-4 and/or DV-6 IF KNOWN VACUUM IS BELOW 1 mTorr SET DISPLAY TO ZERO).
- C. The low end is now adjusted.

3.7.4 Set Low End W/Reference Tube.

- A. Connect HASTINGS reference tube.
- B. Turn the “VAC” pot until the value printed on HASTINGS reference tube is displayed on digital Display.
- C. THE LOW END is now adjusted.

NOTE: If re-calibration is required you must first repeat step 2.

IF SEVERAL TUBES ARE TO BE READ AND RE-CALIBRATION FOR EACH TUBE IS NOT DESIRED, YOU MAY CLEAR THE CALIBRATION DATA (STEP 2) AND ONLY ADJUST THE LOW END SETTING ONCE. HOWEVER A LOSS OF ACCURACY WILL BE NOTICED ON THE HIGH END.

Note: The following table specifies the HASTINGS reference tube to be used in the calibration of a gauge based upon the type of gauge tube being used.

Ref. Tube	Gauge Tube
DB-16D	DV-4
DB-20	DV-6

4. Warranty and Repair

4.1 Warranty Repair Policy

Hastings Instruments warrants this product for a period of one year from the date of shipment to be free from defects in material and workmanship. This warranty does not apply to defects or failures resulting from unauthorized modification, misuse or mishandling of the product. This warranty does not apply to batteries or other expendable parts, nor to damage caused by leaking batteries or any similar occurrence. This warranty does not apply to any instrument which has had a tamper seal removed or broken.

This warranty is in lieu of all other warranties, expressed or implied, including any implied warranty as to fitness for a particular use. Hastings Instruments shall not be liable for any indirect or consequential damages.

Hastings Instruments, will, at its option, repair, replace or refund the selling price of the product if Hastings Instruments determines, in good faith, that it is defective in materials or workmanship during the warranty period. Defective instruments should be returned to Hastings Instruments, **shipment prepaid**, together with a written statement of the problem and a Return Material Authorization (RMA) number. Please consult the factory for your RMA number before returning any product for repair. Collect freight will not be accepted.

4.2 Non-Warranty Repair Policy

Any product returned for a non-warranty repair must be accompanied by a purchase order, RMA form and a written description of the problem with the instrument. If the repair cost is higher, you will be contacted for authorization before we proceed with any repairs. If you then choose not to have the product repaired, a minimum will be charged to cover the processing and inspection. Please consult the factory for your RMA number before returning any product repair.

TELEDYNE HASTINGS INSTRUMENTS
804 NEWCOMBE AVENUE
HAMPTON, VIRGINIA 23669 U.S.A.
ATTENTION: REPAIR DEPARTMENT
TELEPHONE (757) 723-6531
1-800-950-2468
FAX (757) 723-3925
E MAIL mailto:hastings_instruments@teledyne.com
INTERNET ADDRESS <http://www.teledyne-hi.com/>

Repair Forms may be obtained from the "Information Request" section of the Hastings Instruments web site.