



Nor-Cal Products



by PFEIFFER VACUUM



Nor-Cal Products

where technology takes shape

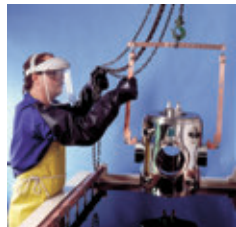
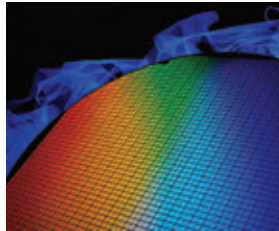
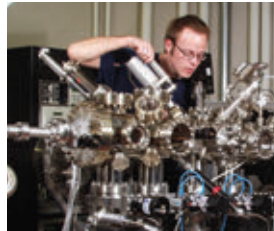

vacuum products catalog

Liquid & Electrical Feedthroughs

Section Ten



10.1	General Information	202
10.2	Liquid Feedthroughs	203
10.3	High Voltage Insulators	205
10.4	Electric Feedthroughs & Connectors	206



Nor-Cal Products, Inc.
 1967 South Oregon St.
 Yreka, CA 96097 USA
 Tel: **800-824-4166**
 or 530-842-4457
 Fax: 530-842-9130
www.n-c.com

Sales Office
 3375 Scott Blvd., Ste. 100
 Santa Clara, CA 95054, USA
 Tel: **408-980-8992**
 Fax: 408-980-8947

Nor-Cal Europe Ltd.
 Suite D, Dittons Engineering Park
 Dittons Road
 Polegate BN26 6HY
 United Kingdom
 Tel: **+44(0)1323 810854**
www.nor-cal.eu

Nor-Cal Korea
 Gadong 2nd Floor, 531-8 Gajang-ro
 Osan-si, Gyeonggi-do,
 South Korea, 18103
 Republic of Korea
 Tel: **+82(0)31-222-6086**
 Fax: +82(0)31-8003-1342

**Nor-Cal Products
 Asia Pacific Pte. Ltd.**
 Serangoon Garden
 P. O. Box 428
 Singapore 915531
 Tel: **+65 6634-1228**
 Fax: +65 6634-1008

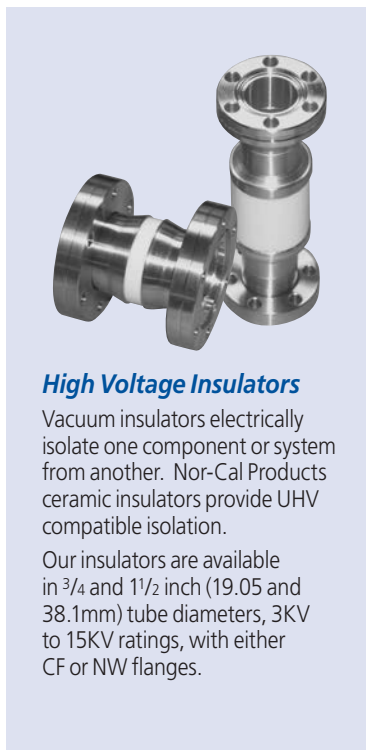

High Voltage Insulators

Vacuum insulators electrically isolate one component or system from another. Nor-Cal Products ceramic insulators provide UHV compatible isolation.

Our insulators are available in $\frac{3}{4}$ and $1\frac{1}{2}$ inch (19.05 and 38.1mm) tube diameters, 3KV to 15KV ratings, with either CF or NW flanges.

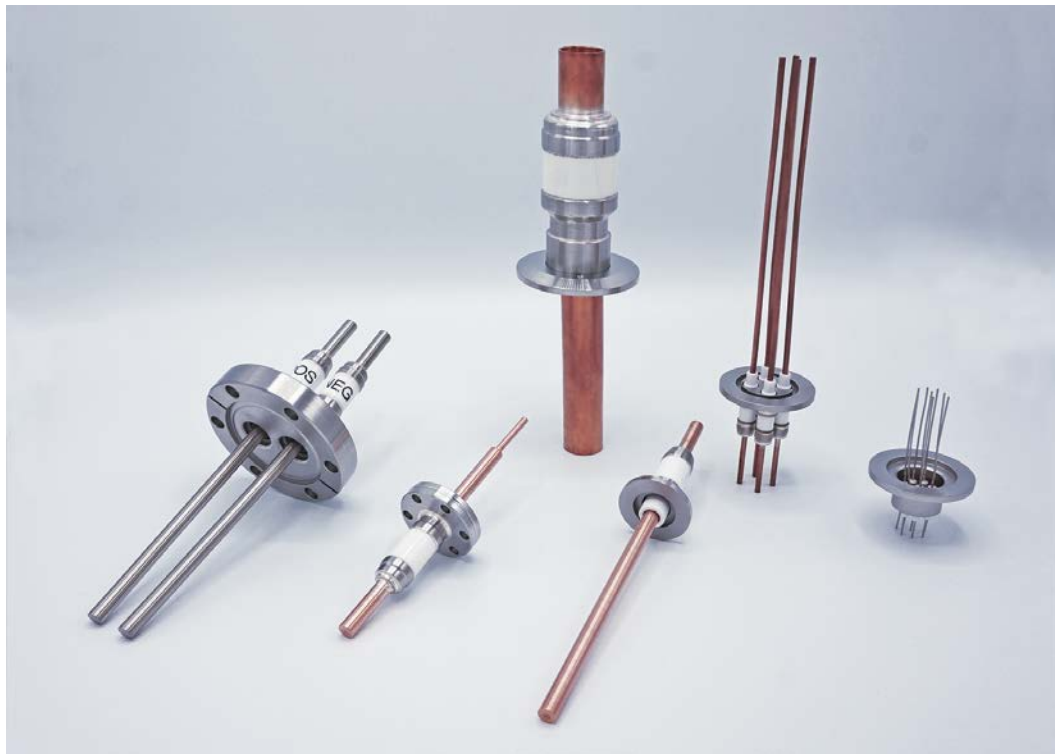

Liquid Feedthroughs

Nor-Cal Products' line of liquid and liquid nitrogen feedthroughs includes the most commonly required for medium, high and ultrahigh vacuum applications. Tubing is .25 and .375 (6.35 and 9.53mm) inch OD, 304 stainless steel with CF or NW flanges. They are available without fittings or terminated with industry standard Swagelok or Cajon VCR fittings. Maximum bakeout with CF flanges is 450°C and 200°C with NWs. Vacuum ranges are 10^{-10} mbar and 10^{-8} , respectively.

Liquid feedthroughs are a cost-effective and reliable way to introduce water into a vacuum system. The .035 inch (.89mm) single wall tube construction is designed for the transport of water as a cooling agent.

Liquid nitrogen feedthroughs are constructed with single and dual coaxial tube geometries. This thermal barrier effectively reduces condensation and ice buildup on the atmosphere side of the feedthrough around the mounting flange interface, protecting the seal's integrity. This is necessary because of the extreme thermal gradients encountered with liquid nitrogen.

Swagelok stainless steel tube compression fittings provide a leakproof, torque-free vacuum seal by swaging the stainless steel tube to which they are mated. These fittings require no gaskets.

Cajon VCR stainless steel compression fittings provide a quick and efficient means of vacuum system assembly. These zero-clearance fittings make them the perfect installation solution when space is limited. Compression of a removable copper gasket creates a vacuum seal between the air and process sides.

Electrical Feedthroughs

Nor-Cal Products' extensive line of electrical feedthroughs are manufactured from ultra-high vacuum grade materials such as high alumina ceramic insulators, OFHC copper or nickel conductors, and 304 stainless steel flanges.

These robust ceramic to metal feedthroughs have electrical ratings for operation with one side in dry atmosphere while the opposite end is in a stable vacuum. They are used in UHV systems with CF flanges or high vacuum systems with NW flanges. CF feedthroughs can be baked to 450°C and NWs to 200°C. Our product line consists of the most commonly required feedthroughs for general vacuum applications. Custom designs or modified standards can readily be supplied.

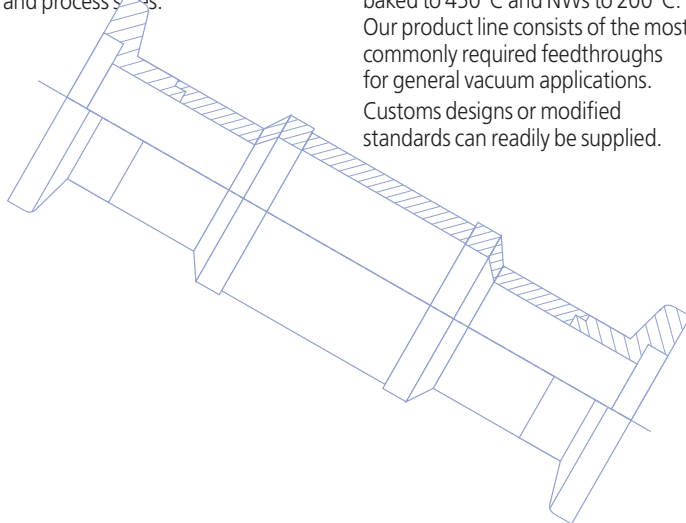

All dimensions are in inches (mm) & weights are in pounds (kg), unless otherwise noted.

Single Liquid Feedthroughs

MODEL NUMBER	FLANGE	TUBE FITTINGS	TUBE OD	A	B
LFT-NW-16-1-025	NW-16	None	0.250 (6.35)	3.00 (76.20)	4.00 (101.60)
LFT-NW-25-1-025	NW-25	None	0.250 (6.35)	3.00 (76.20)	4.00 (101.60)
LFT-NW-25-1-025-2SW	NW-25	2 Swagelok	0.250 (6.35)	4.01 (101.85)	5.01 (127.25)
LFT-NW-25-1-025-2MVCR	NW-25	2 MVCR	0.250 (6.35)	4.03 (102.36)	5.03 (127.76)
LFT-NW-40-1-025	NW-40	None	0.250 (6.35)	3.00 (76.20)	4.00 (101.60)
LFT-NW-40-1-025-2SW	NW-40	2 Swagelok	0.250 (6.35)	4.01 (101.85)	5.01 (127.25)
LFT-NW-40-1-025-2MVCR	NW-40	2 MVCR	0.250 (6.35)	4.03 (102.36)	5.03 (127.76)
LFT-NW-40-1-038	NW-40	None	0.375 (9.53)	3.00 (76.20)	4.00 (101.60)
LFT-NW-50-1-025	NW-50	None	0.250 (6.35)	3.00 (76.20)	4.00 (101.60)
LFT-NW-50-1-025-2SW	NW-50	2 Swagelok	0.250 (6.35)	4.01 (101.85)	5.01 (127.25)
LFT-NW-50-1-025-2MVCR	NW-50	2 MVCR	0.250 (6.35)	4.03 (102.36)	5.03 (127.76)
LFT-NW-50-1-038	NW-50	None	0.375 (9.53)	3.00 (76.20)	4.00 (101.60)
LFT-075-1-025	1.33 CF	None	0.250 (6.35)	3.00 (76.20)	4.00 (101.60)
LFT-075-1-038	2.75 CF	None	0.375 (9.53)	3.00 (76.20)	4.00 (101.60)
LFT-150-1-025	2.75 CF	None	0.250 (6.35)	3.00 (76.20)	4.00 (101.60)
LFT-150-1-025-2SW	2.75 CF	2 Swagelok	0.250 (6.35)	4.01 (101.85)	5.01 (127.25)
LFT-150-1-025-2MVCR	2.75 CF	2 MVCR	0.250 (6.35)	4.03 (102.36)	5.03 (127.76)
LFT-150-1-038	2.75 CF	None	0.375 (9.53)	3.00 (76.20)	4.00 (101.60)

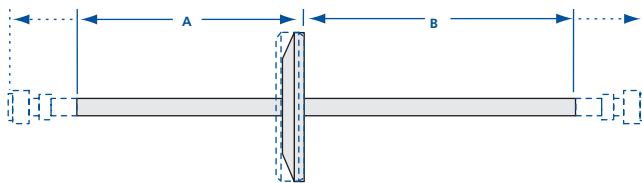

SPECIFICATIONS

Materials

Flange: 304 stainless steel

Vacuum range

Metal seal: $\geq 10^{-10}$ mbar (UHV)
Elastomer seal: $\geq 10^{-8}$ mbar (High vacuum)

Temperature range

Metal seal: -270°C to 450°C
Elastomer seal: -20°C to 200°C

Dual Liquid Feedthroughs

MODEL NUMBER	FLANGE	TUBE FITTINGS	TUBE OD	A	B
LFT-NW-40-2-025	NW-40	None	0.250 (6.35)	3.00 (76.20)	4.00 (101.60)
LFT-NW-40-2-025-4SW	NW-40	4 Swagelok	0.250 (6.35)	4.01 (101.85)	5.01 (127.25)
LFT-NW-40-2-025-4MVCR	NW-40	4 MVCR	0.250 (6.35)	4.03 (102.36)	5.03 (127.76)
LFT-NW-50-2-025	NW-50	None	0.250 (6.35)	3.00 (76.20)	4.00 (101.60)
LFT-NW-50-2-025-4SW	NW-50	4 Swagelok	0.250 (6.35)	4.01 (101.85)	5.01 (127.25)
LFT-NW-50-2-025-4MVCR	NW-50	4 MVCR	0.250 (6.35)	4.03 (102.36)	5.03 (127.76)
LFT-150-2-025	2.75 CF	None	0.250 (6.35)	3.00 (76.20)	4.00 (101.60)
LFT-150-2-025-4SW	2.75 CF	4 Swagelok	0.250 (6.35)	4.01 (101.85)	5.01 (127.25)
LFT-150-2-025-4MVCR	2.75 CF	4 MVCR	0.250 (6.35)	4.03 (102.36)	5.03 (127.76)
LFT-150-2-038	2.75 CF	None	0.375 (9.53)	3.00 (76.20)	4.00 (101.60)

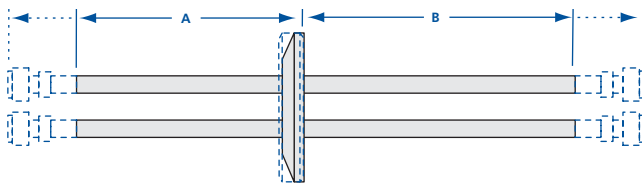

SPECIFICATIONS

Materials

Flange: 304 stainless steel

Vacuum range

Metal seal: $\geq 10^{-10}$ mbar (UHV)
Elastomer seal: $\geq 10^{-8}$ mbar (High vacuum)

Temperature range

Metal seal: -270°C to 450°C
Elastomer seal: -20°C to 200°C

All dimensions for optional fittings are referenced from the seal face

All dimensions are in inches (mm) & weights are in pounds (kg), unless otherwise noted.





Single Liquid Nitrogen Feedthroughs

SPECIFICATIONS

- Materials**
Flange: 304 stainless steel
- Vacuum range**
Metal seal: $\geq 10^{-10}$ mbar (UHV)
Elastomer seal: $\geq 10^{-8}$ mbar (High vacuum)
- Temperature range**
Metal seal: -270°C to 450°C
Elastomer seal: -20°C to 200°C

MODEL NUMBER	FLANGE	TUBE FITTINGS	TUBE OD	A	B
LNF-NW-16-1-025	NW-16	None	0.250 (6.35)	5.50 (139.70)	4.50 (114.30)
LNF-NW-25-1-025	NW-25	None	0.250 (6.35)	5.50 (139.70)	4.50 (114.30)
LNF-NW-25-1-025-2SW	NW-25	2 Swagelok	0.250 (6.35)	6.51 (165.35)	5.51 (139.95)
LNF-NW-25-1-025-2MVCR	NW-25	2 MVCR	0.250 (6.35)	6.53 (165.86)	5.53 (140.46)
LNF-NW-40-1-025	NW-40	None	0.250 (6.35)	5.50 (139.70)	4.50 (114.30)
LNF-NW-40-1-025-2SW	NW-40	2 Swagelok	0.250 (6.35)	6.51 (165.35)	5.51 (139.95)
LNF-NW-40-1-025-2MVCR	NW-40	2 MVCR	0.250 (6.35)	6.53 (165.86)	5.53 (140.46)
LNF-NW-40-1-038	NW-40	None	0.375 (9.53)	5.50 (139.70)	4.50 (114.30)
LNF-NW-50-1-025	NW-50	None	0.250 (6.35)	5.50 (139.70)	4.50 (114.30)
LNF-NW-50-1-025-2SW	NW-50	2 Swagelok	0.250 (6.35)	6.51 (165.35)	5.51 (139.95)
LNF-NW-50-1-025-2MVCR	NW-50	2 MVCR	0.250 (6.35)	6.53 (165.86)	5.53 (140.46)
LNF-NW-50-1-038	NW-50	None	0.375 (9.53)	5.50 (139.70)	4.50 (114.30)
LNF-075-1-025	1.33 CF	None	0.250 (6.35)	5.50 (139.70)	4.50 (114.30)
LNF-075-1-038	1.33 CF	None	0.375 (9.53)	5.50 (139.70)	4.50 (114.30)
LNF-150-1-025	2.75 CF	None	0.250 (6.35)	5.50 (139.70)	4.50 (114.30)
LNF-150-1-025-2SW	2.75 CF	2 Swagelok	0.250 (6.35)	6.51 (165.35)	5.51 (139.95)
LNF-150-1-025-2MVCR	2.75 CF	2 MVCR	0.250 (6.35)	6.53 (165.86)	5.53 (140.46)
LNF-150-1-038	2.75 CF	None	0.375 (9.53)	5.50 (139.70)	4.50 (114.30)

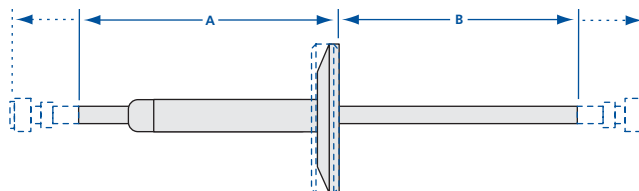

Dual Liquid Nitrogen Feedthroughs

SPECIFICATIONS

- Materials**
Flange: 304 stainless steel
- Vacuum range**
Metal seal: $\geq 10^{-10}$ mbar (UHV)
Elastomer seal: $\geq 10^{-8}$ mbar (High vacuum)
- Temperature range**
Metal seal: -270°C to 450°C
Elastomer seal: -20°C to 200°C

MODE NUMBER	FLANGE	TUBE FITTINGS	TUBE	A	B	C	D
LNF-NW-40-2-025	NW-40	None	0.250 (6.35)	6.50 (165.10)	3.50 (88.90)	5.50 (139.70)	4.50 (114.30)
LNF-NW-40-2-025-4SW	NW-40	4 Swagelok	0.250 (6.35)	7.51 (190.75)	4.51 (114.55)	6.51 (165.35)	5.51 (139.95)
LNF-NW-40-2-025-4MVCR	NW-40	4 MVCR	0.250 (6.35)	7.53 (191.26)	4.53 (115.06)	6.53 (165.86)	5.53 (140.46)
LNF-NW-50-2-025	NW-50	None	0.250 (6.35)	6.50 (165.10)	3.50 (88.90)	5.50 (139.70)	4.50 (114.30)
LNF-NW-50-2-025-4SW	NW-50	4 Swagelok	0.250 (6.35)	7.51 (190.75)	4.51 (114.55)	6.51 (165.35)	5.51 (139.95)
LNF-NW-50-2-025-4MVCR	NW-50	4 MVCR	0.250 (6.35)	7.53 (191.26)	4.53 (115.06)	6.53 (165.86)	5.53 (140.46)
LNF-150-2-025	2.75 CF	None	0.250 (6.35)	6.50 (165.10)	3.50 (88.90)	5.50 (139.70)	4.50 (114.30)
LNF-150-2-025-4SW	2.75 CF	4 Swagelok	0.250 (6.35)	7.51 (190.75)	4.51 (114.55)	6.51 (165.35)	5.51 (139.95)
LNF-150-2-025-4MVCR	2.75 CF	4 MVCR	0.250 (6.35)	7.53 (191.26)	4.53 (115.06)	6.53 (165.86)	5.53 (140.46)
LNF-150-2-038	2.75 CF	None	0.375 (9.53)	6.50 (165.10)	3.50 (88.90)	5.50 (139.70)	4.50 (114.30)

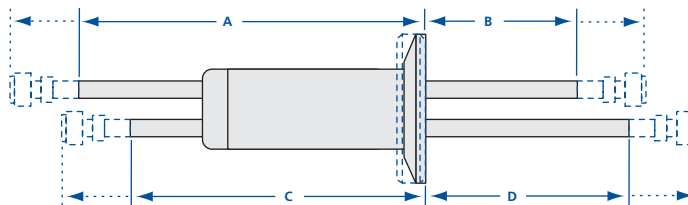

All dimensions for optional fittings are referenced from the seal face

All dimensions are in inches (mm) & weights are in pounds (kg), unless otherwise noted.

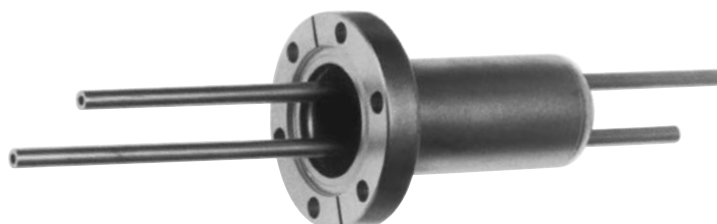

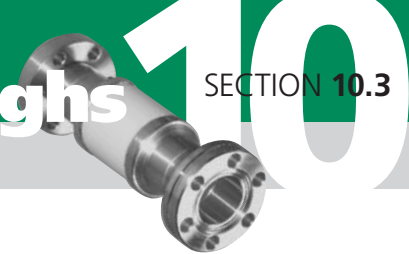

Vacuum insulators (also known as vacuum breaks and isolators) are used to electrically isolate one component or system from another. Nor-Cal uses a ceramic insulator with 95% minimum aluminum oxide content, which is silver brazed to two Kovar sleeves, creating a UHV compatible insulator. The insulator is then welded to the appropriate vacuum flange. Standard vacuum insulators are available in two tube diameters, 3/4 and 1 1/2 inches (19.05 and 38.1mm). The 3/4 inch (19.05mm) size is rated up to 10KV, while the 1 1/2 inch (38.1mm) size is offered in two voltage ratings (3KV and 15KV). All three voltage ratings are available with either two NW (ISO-KF) flanges for high vacuum applications or with one non-rotatable and rotatable CF (Conflat) flange for ultra-high vacuum applications. Other sizes, current ratings and flange combinations are available on request.

SPECIFICATIONS

Materials

Flanges: 304 stainless steel
Sleeve: Kovar
Insulator: Ceramic
(95% aluminum oxide content)
Magnetic: Yes

Vacuum range

Metal seal: $\geq 10^{-13}$ mbar (UHV)
Elastomer seal: $\geq 10^{-8}$ mbar (High vacuum)

Temperature range

Metal seal: $\leq 450^\circ\text{C}$
Elastomer seal: $\leq 150^\circ\text{C}$ sustained,
 $\leq 200^\circ\text{C}$ intermittent
Gradient: $25^\circ\text{C}/\text{minute}$ maximum

CF High Voltage Insulators

MODEL NUMBER	TUBE OD	MAX. VOLTAGE (kV)	A	B	C	D	E	F
HVI-075-10	3/4 (19.05)	15	3.62 (91.95)	1.00 (25.40)	0.63 (16.00)	1.33 (33.78)	1.04 (26.42)	0.75 (19.05)
HVI-150-3	1 1/2 (38.10)	5	2.65 (67.31)	0.25 (6.35)	1.37 (34.80)	2.73 (69.34)	1.66 (42.16)	1.25 (31.75)
HVI-150-15	1 1/2 (38.10)	30	4.20 (106.68)	2.00 (50.80)	1.37 (34.80)	2.73 (69.34)	1.66 (42.16)	1.25 (31.75)

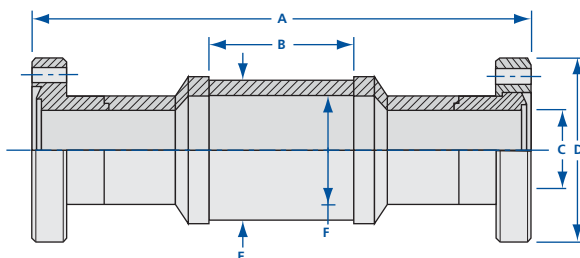

NW High Voltage Insulators

MODEL NUMBER	TUBE OD	MAX. VOLTAGE (kV)	A	B	C	D	E	F
HVI-NW-16-10	3/4 (19.05)	15	3.62 (91.95)	1.00 (25.40)	0.63 (16.00)	1.18 (29.97)	1.04 (26.42)	0.75 (19.05)
HVI-NW-40-3	1 1/2 (38.10)	5	2.28 (57.91)	0.25 (6.35)	1.37 (34.80)	2.16 (54.86)	1.66 (42.16)	1.25 (31.75)
HVI-NW-40-15	1 1/2 (38.10)	30	4.03 (102.36)	2.00 (50.8)	1.37 (34.80)	2.16 (54.86)	1.66 (42.16)	1.25 (31.75)

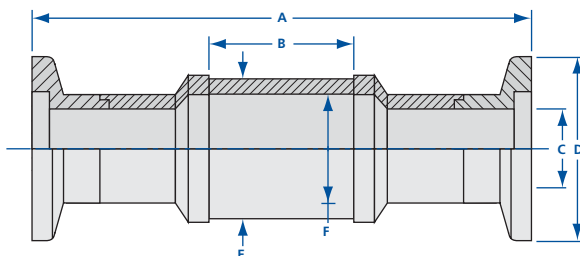

All dimensions are in inches (mm) & weights are in pounds (kg), unless otherwise noted.



SPECIFICATIONS

Materials

Flange: 304 stainless steel
Conductors: OFHC copper
Insulator: Alumina ceramic

Electrical

Voltage: 5 KVDC
Current: 150 Amps

Connector: Use with vacuum connector
MCF-VC (see page 216)

Vacuum range

Metal seal: $\geq 10^{-10}$ mbar (UHV)
Elastomer seal: $\geq 10^{-8}$ mbar (High vacuum)

Temperature range

Metal seal: -270°C to 450°C
Elastomer seal: -20°C to 200°C

Medium Current Copper Feedthroughs

These electrical feedthroughs transmit either high voltage, high current or a combination of both. They are used for sample heating, in-vacuum coating, electron beam evaporation, sputtering and other high vacuum applications. High-purity, high-strength, low-loss alumina ceramic surfaces maximize strike and creep distances. The air-side ceramic surfaces have a high temperature glass coating which reduces surface roughness and contamination.

MODEL NUMBER	FLANGE	NUMBER OF FEEDTHROUGHS	A	B
MCF-NW-16-1	NW-16	1	3.23 (82.04)	4.03 (102.36)
MCF-NW-25-1	NW-25	1	3.23 (82.04)	4.03 (102.36)
MCF-NW-40-1	NW-40	1	3.13 (79.50)	4.13 (104.90)
MCF-NW-40-2	NW-40	2	3.23 (82.04)	4.03 (102.36)
MCF-NW-40-3	NW-40	3	3.23 (82.04)	4.03 (102.36)
MCF-NW-40-4	NW-40	4	3.23 (82.04)	4.03 (102.36)
MCF-NW-50-1	NW-50	1	3.13 (79.50)	4.13 (104.90)
MCF-NW-50-2	NW-50	2	3.23 (82.04)	4.03 (102.36)
MCF-NW-50-3	NW-50	3	3.23 (82.04)	4.03 (102.36)
MCF-NW-50-4	NW-50	4	3.23 (82.04)	4.03 (102.36)
MCF-075-1	1.33 CF	1	3.21 (81.53)	4.05 (102.87)
MCF-150-1	2.75 CF	1	3.18 (80.77)	4.08 (103.63)
MCF-150-2	2.75 CF	2	3.18 (80.77)	4.08 (103.63)
MCF-150-3	2.75 CF	3	3.18 (80.77)	4.08 (103.63)
MCF-150-4	2.75 CF	4	3.18 (80.77)	4.08 (103.63)

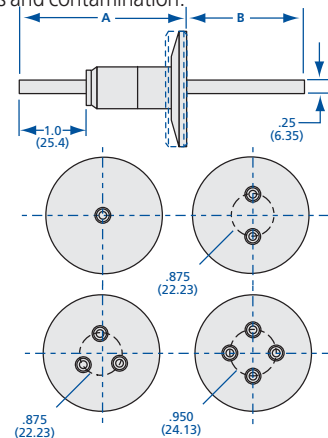

Medium Current Nickel Feedthroughs

The nickel rod conductors on these electrical feedthroughs offer an alternative to copper for use in environments and processes that attack copper surfaces.

MODEL NUMBER	FLANGE	NUMBER OF FEEDTHROUGHS	A	B
MCF-NW-16-1N	NW-16	1	3.23 (82.04)	4.03 (102.36)
MCF-NW-25-1N	NW-25	1	3.23 (82.04)	4.03 (102.36)
MCF-NW-40-1N	NW-40	1	3.13 (79.50)	4.13 (104.90)
MCF-NW-40-2N	NW-40	2	3.23 (82.04)	4.03 (102.36)
MCF-NW-40-3N	NW-40	3	3.23 (82.04)	4.03 (102.36)
MCF-NW-40-4N	NW-40	4	3.23 (82.04)	4.03 (102.36)
MCF-NW-50-1N	NW-50	1	3.13 (79.50)	4.13 (104.90)
MCF-NW-50-2N	NW-50	2	3.23 (82.04)	4.03 (102.36)
MCF-NW-50-3N	NW-50	3	3.23 (82.04)	4.03 (102.36)
MCF-NW-50-4N	NW-50	4	3.23 (82.04)	4.03 (102.36)
MCF-075-1N	1.33 CF	1	3.21 (81.53)	4.05 (102.87)
MCF-150-1N	2.75 CF	1	3.18 (80.77)	4.08 (103.63)
MCF-150-2N	2.75 CF	2	3.18 (80.77)	4.08 (103.63)
MCF-150-3N	2.75 CF	3	3.18 (80.77)	4.08 (103.63)
MCF-150-4N	2.75 CF	4	3.18 (80.77)	4.08 (103.63)

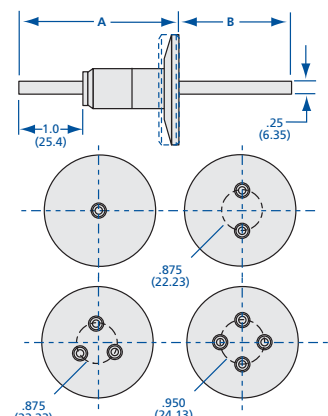

Water Cooled Medium Current Copper Feedthroughs

These water cooled electrical feedthroughs transmit power and coolants simultaneously. They conduct higher current loads than solid rod conductors of equal size when properly cooled. Grounding of system is necessary for safety.

MODEL NUMBER	FLANGE	NUMBER OF FEEDTHROUGHS	A	B
MCF-NW-16-1W	NW-16	1	3.23 (82.04)	4.03 (102.36)
MCF-NW-25-1W	NW-25	1	3.23 (82.04)	4.03 (102.36)
MCF-NW-40-1W	NW-40	1	3.13 (79.50)	4.13 (104.90)
MCF-NW-40-2W	NW-40	2	3.23 (82.04)	4.03 (102.36)
MCF-NW-40-3W	NW-40	3	3.23 (82.04)	4.03 (102.36)
MCF-NW-40-4W	NW-40	4	3.23 (82.04)	4.03 (102.36)
MCF-NW-50-1W	NW-50	1	3.13 (79.50)	4.13 (104.90)
MCF-NW-50-2W	NW-50	2	3.23 (82.04)	4.03 (102.36)
MCF-NW-50-3W	NW-50	3	3.23 (82.04)	4.03 (102.36)
MCF-NW-50-4W	NW-50	4	3.23 (82.04)	4.03 (102.36)
MCF-075-1W	1.33 CF	1	3.21 (81.53)	4.05 (102.87)
MCF-150-1W	2.75 CF	1	3.18 (80.77)	4.08 (103.63)
MCF-150-2W	2.75 CF	2	3.18 (80.77)	4.08 (103.63)
MCF-150-3W	2.75 CF	3	3.18 (80.77)	4.08 (103.63)
MCF-150-4W	2.75 CF	4	3.18 (80.77)	4.08 (103.63)

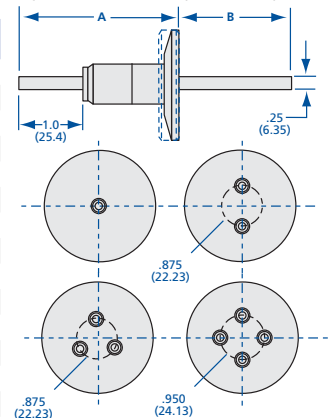

SPECIFICATIONS

Materials

Flange: 304 stainless steel
Conductors: OFHC copper tube
Insulator: Alumina ceramic

Electrical

Voltage: 12 KVDC

Vacuum range

Metal seal: $\geq 10^{-10}$ mbar (UHV)
Elastomer seal: $\geq 10^{-8}$ mbar (High vacuum)

Temperature range

Metal seal: -270°C to 450°C
Elastomer seal: -20°C to 200°C

All dimensions are in inches (mm) & weights are in pounds (kg), unless otherwise noted.

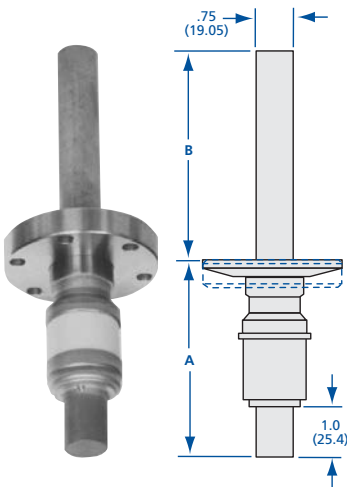

Single High Current Copper Feedthroughs

These electrical power feedthroughs accommodate a higher electrical current due to the size of the copper rod.

MODEL NUMBER	FLANGE	CURRENT	A	B
HCF-NW-40-1	NW-40	600 Amps	3.85 (97.79)	3.40 (86.36)
HCF-NW-50-1	NW-50	600 Amps	3.85 (97.79)	3.40 (86.36)
HCF-150-1	2.75 CF	600 Amps	3.90 (99.06)	3.35 (85.09)

Single Water Cooled High Current Copper Feedthroughs

MODEL NUMBER	FLANGE	A	B
HCF-NW-40-1W	NW-40	3.85 (97.79)	3.40 (86.36)
HCF-NW-50-1W	NW-50	8.85 (224.79)	3.40 (86.36)
HCF-150-1W	2.75 CF	3.90 (99.06)	3.35 (85.09)

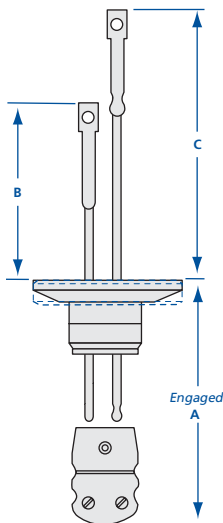

Thermocouple Feedthroughs

Thermocouple feedthroughs carry instrumentation signals while providing electrical isolation and hermetic sealing. They are leak free in high and ultra high vacuum environments and are composed of only inorganic materials. The insulators are made of high purity, high strength, low-loss alumina ceramic.

MODEL NUMBER	FLANGE	A	B	C
TC-NW-16-1	NW-16	2.40 (60.96)	3.00 (76.20)	4.00 (101.60)
TC-NW-25-1	NW-25	2.02 (51.31)	3.38 (85.85)	4.38 (111.25)
TC-NW-40-1	NW-40	1.90 (48.26)	3.50 (88.90)	4.50 (114.30)
TC-NW-50-1	NW-50	1.90 (48.26)	3.50 (88.90)	4.50 (114.30)
TC-075-1	1.33 CF	2.40 (60.96)	3.00 (76.20)	4.00 (101.60)
TC-150-1	2.75 CF	1.95 (49.53)	3.45 (87.63)	4.45 (113.03)

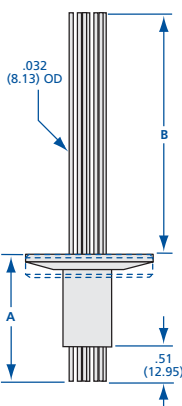

8-Pin Instrumentation Feedthroughs

Multipin instrumentation feedthroughs are typically used to transmit signal voltages and currents. Applications such as electron beam evaporation, electron microscopy and surface science analysis utilize these feedthroughs to control processes.

MODEL NUMBER	FLANGE	A	B
IFT-NW-16-8P	NW-16	1.32 (33.53)	1.18 (29.97)
IFT-NW-25-8P	NW-25	0.92 (23.37)	1.58 (40.13)
IFT-NW-40-8P	NW-40	0.82 (20.83)	1.68 (42.67)
IFT-NW-50-8P	NW-50	0.82 (20.83)	1.68 (42.67)
IFT-075-8P	1.33 CF	1.32 (33.53)	1.18 (29.97)
IFT-150-8P	2.75 CF	0.87 (22.10)	1.63 (41.40)

SPECIFICATIONS

Materials
 Flange: 304 stainless steel
 Conductors: OFHC copper
 Insulator: Alumina ceramic

Electrical
 Voltage: 3 KVDC peak

Vacuum Range
 Metal Seal: $\geq 10^{-10}$ mbar (UHV)
 Elastomer Seal: $\geq 10^{-8}$ mbar (High vacuum)

Temperature Range
 Metal seal: -270°C to 450°C
 Elastomer seal: -20°C to 200°C

SPECIFICATIONS

Materials
 Flange: 304 stainless steel
 Conductors: Chromel/Alumel
 Insulator: Alumina ceramic

Connectors
 Plug color: Yellow
 Thermocouple: Type K

Included hardware: Plugs, screws and nuts for vacuum and atmosphere lead attachment

Vacuum range
 Metal seal: $\geq 10^{-10}$ mbar (UHV)
 Elastomer seal: $\geq 10^{-8}$ mbar (High vacuum)

Temperature range
 Metal seal: -270°C to 450°C
 (plug disconnected)
 Elastomer seal: -20°C to 150°C

SPECIFICATIONS

Materials
 Flange: 304 stainless steel
 Conductors: 0.032 OD nickel wire
 Insulator: Alumina ceramic

Electrical
 Voltage: 500 VDC
 Current: 2 Amps

Connector: Use with vacuum connector IFT-VC (see page 216)

Vacuum range
 Metal seal: $\geq 10^{-10}$ mbar (UHV)
 Elastomer seal: $\geq 10^{-8}$ mbar (High vacuum)

Temperature range
 Metal seal: -270°C to 450°C
 Elastomer seal: -20°C to 200°C



BNC Coaxial Feedthroughs

The BNC (Bayonet Naval Connection) electrical feedthrough consists of two concentric conductor paths which are separated and insulated with high-purity alumina ceramic. It is commonly used in 50 to 70 ohm low power instrumentation lines.

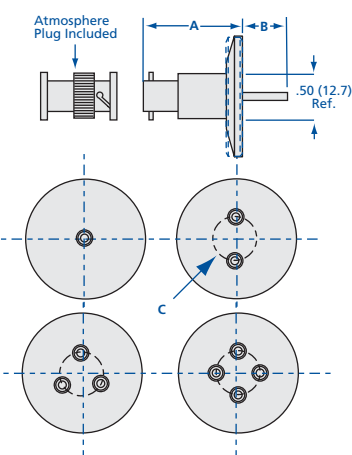

SPECIFICATIONS

Materials	
Flange:	304 stainless steel
Conductors:	Stainless steel
Insulator:	Alumina ceramic
Electrical	
Voltage:	500 VDC @10 ⁻⁴ mbar
Current:	3 Amps
Connector: Use with vacuum connector BNC-VC (see below), atmosphere connector included	
Vacuum range	
Metal seal:	≥10 ⁻¹⁰ mbar (UHV)
Elastomer seal:	≥10 ⁻⁸ mbar (High vacuum)
Temperature range	
Metal seal:	-270°C to 450°C
Elastomer seal:	-20°C to 200°C

MODEL NUMBER	FLANGE	NUMBER OF FEEDTHROUGHS	A	B	C
BNC-NW-16-1	NW-16	1	1.43 (36.32)	0.32 (8.13)	-
BNC-NW-25-1	NW-25	1	1.43 (36.32)	0.32 (8.13)	-
BNC-NW-40-1	NW-40	1	1.33 (33.78)	0.42 (10.67)	-
BNC-NW-40-2	NW-40	2	1.33 (33.78)	0.42 (10.67)	0.75 (19.05)
BNC-NW-40-3	NW-40	3	1.33 (33.78)	0.42 (10.67)	0.75 (19.05)
BNC-NW-40-4	NW-40	4	1.43 (36.32)	0.32 (8.13)	0.90 (22.86)
BNC-NW-50-1	NW-50	1	1.33 (33.78)	0.42 (10.67)	-
BNC-NW-50-2	NW-50	2	1.33 (33.78)	0.42 (10.67)	0.75 (19.05)
BNC-NW-50-3	NW-50	3	1.33 (33.78)	0.42 (10.67)	0.75 (19.05)
BNC-NW-50-4	NW-50	4	1.33 (33.78)	0.42 (10.67)	0.90 (22.86)
BNC-075-1	1.33 CF	1	1.41 (35.81)	0.34 (8.640)	-
BNC-150-1	2.75 CF	1	1.38 (35.05)	0.37 (9.40)	-
BNC-150-2	2.75 CF	2	1.38 (35.05)	0.37 (9.40)	0.95 (24.13)
BNC-150-3	2.75 CF	3	1.38 (35.05)	0.37 (9.40)	0.95 (24.13)
BNC-150-4	2.75 CF	4	1.38 (35.05)	0.37 (9.40)	0.95 (24.13)

MHV Coaxial Feedthroughs

The MHV (Miniature High Voltage or High Voltage BNC) electrical feedthroughs operate in medium to high power with higher voltage requirements. MHV and BNC feedthroughs look similar but are very different in electrical rating. They should never be cross-mated since their electrical ratings are not compatible.

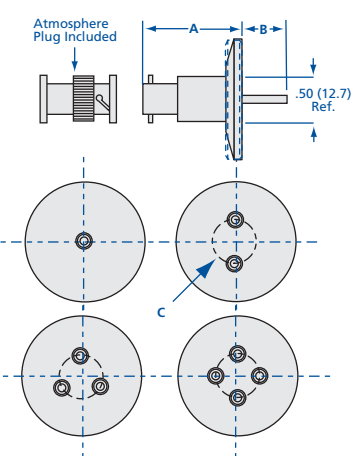

SPECIFICATIONS

Materials	
Flange:	304 stainless steel
Conductors:	Stainless steel
Insulator:	Alumina ceramic
Electrical	
Voltage:	5 KV
Current:	3 Amps
Connector: Use with vacuum connector MCF-VC (see below), atmosphere connector included	
Vacuum range	
Metal seal:	≥10 ⁻¹⁰ mbar (UHV)
Elastomer seal:	≥10 ⁻⁸ mbar (High vacuum)
Temperature range	
Metal seal:	-270°C to 450°C
Elastomer seal:	-20°C to 200°C

MODEL NUMBER	FLANGE	NUMBER OF FEEDTHROUGHS	A	B	C
MHV-NW-16-1	NW-16	1	1.43 (36.32)	0.25 (6.35)	-
MHV-NW-25-1	NW-25	1	1.43 (36.32)	0.25 (6.25)	-
MHV-NW-40-1	NW-40	1	1.33 (33.78)	0.35 (8.89)	-
MHV-NW-40-2	NW-40	2	1.33 (33.78)	0.35 (8.89)	0.75 (19.05)
MHV-NW-40-3	NW-40	3	1.33 (33.78)	0.35 (8.89)	0.75 (19.05)
MHV-NW-40-4	NW-40	4	1.43 (36.32)	0.25 (6.35)	0.90 (22.86)
MHV-NW-50-1	NW-50	1	1.33 (33.78)	0.35 (8.89)	-
MHV-NW-50-2	NW-50	2	1.33 (33.78)	0.35 (8.89)	0.75 (19.05)
MHV-NW-50-3	NW-50	3	1.33 (33.78)	0.35 (8.89)	0.75 (19.05)
MHV-NW-50-4	NW-50	4	1.33 (33.78)	0.35 (8.89)	0.90 (22.86)
MHV-075-1	1.33 CF	1	1.41 (35.81)	0.27 (6.86)	-
MHV-150-1	2.75 CF	1	1.38 (35.05)	0.30 (7.62)	-
MHV-150-2	2.75 CF	2	1.38 (35.05)	0.30 (7.62)	0.95 (24.13)
MHV-150-3	2.75 CF	3	1.38 (35.05)	0.30 (7.62)	0.95 (24.13)
MHV-150-4	2.75 CF	4	1.38 (35.05)	0.30 (7.62)	0.95 (24.13)

Electrical Feedthrough Connectors

MODEL NUMBER	USE WITH	MATERIAL	MAXIMUM CURRENT (AMPS)	QUANTITY
MCF-VC	Medium Current	Beryllium Copper with SS Screws	100	10 per Pkg.
BNC-VC	BNC and MHV	Beryllium Copper with SS Screws	15	10 per Pkg.
IFT-VC	8-Pin Instrumentation	Beryllium Copper	10	10 per Pkg.

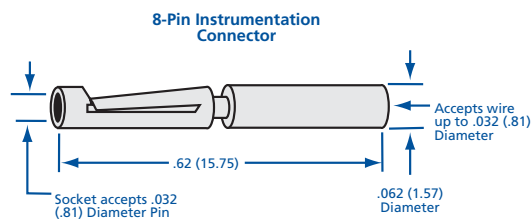
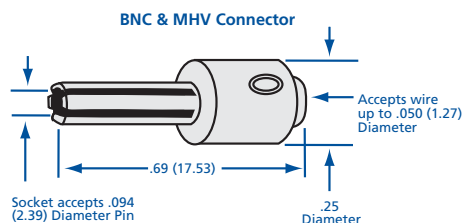
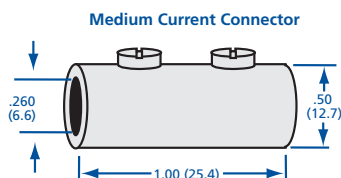

Order Information

Regional Sales Contacts

Nor-Cal Products



by PFEIFFER VACUUM

Manufacturing & Corporate Global Headquarters

1967 South Oregon Street, Yreka, CA 96097

Phone: 530-842-4457 | Toll Free: 800-824-4166 | Fax: 530-842-9189

Silicon Valley Sales & Applications Office

3375 Scott Blvd., Suite 100, Santa Clara, CA 95054

Phone: 408-980-8992 | Fax: 408-980-8947 | E-mail: ncsales@n-c.com

DIRECT SALES:

www.n-c.com | 1-800-824-4166 | ncsales@n-c.com

Locate your
sales representative
at
www.n-c.com/sales
or call
800-824-4166
for assistance

Send drawings
and quote
requests to
ncsales@n-c.com

Follow us on
LinkedIn

Sylvie Bouhier

*European
Regional Sales Manager*

Ph: +44 (0)799 057 1405
sbouhier@nor-cal.eu

Nor-Cal Products, Europe

Suite D, Dittons Engineering Park
Dittons Road, Polegate BN26 6HY
United Kingdom

Ph: +44 (0)1323 810 854

www.nor-cal.eu

Lena Tan

*Asia-Pacific
Regional Sales Manager*

Ph: +65 6634-1228
sales@n-c.asia

Nor-Cal Products, Asia Pacific

2 Ang Mo Kio Street 64 #01-03A
ECON Industrial Building
Singapore 569084

MAILING ADDRESS:

Nor-Cal Products, Asia Pacific

Serangoon Garden
P. O. Box 428
Singapore 915531

IT Jang

*South Korea
Regional Sales Manager*

Ph: +82-10-7554-0117
itjang@n-c.com

Nor-Cal Products, South Korea

Gadong 2nd Floor, 531-8 Gajang-ro,
Osan-si, Gyeonggi-do,
South Korea, 18103
Republic of Korea

Ph: +82-31-8003-1341

Fax: +82-31-8003-1342

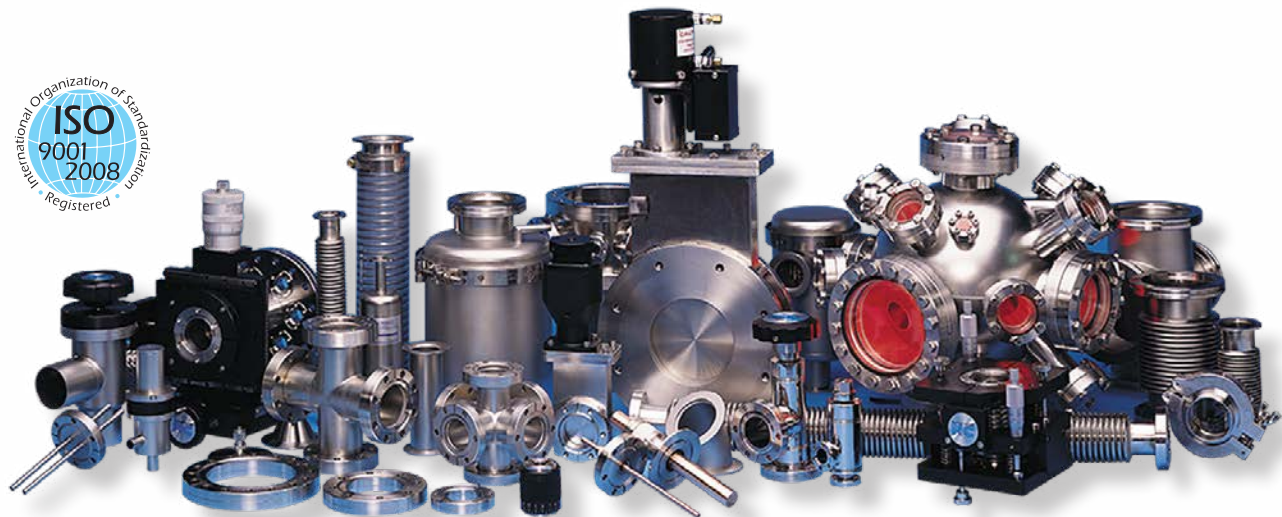

Terms & Conditions of Sale

Payment terms are net 30 days from the date of the invoice once credit has been approved. Otherwise, C.O.D. Most major credit cards are accepted.

If payment in full is not received within 30 days, a 1.5% per month late charge may be added to the unpaid balance. Discounts may be revoked if an account is not paid within these terms.

MINIMUM ORDERS: The minimum domestic order is \$40. The minimum international order is \$100.00.

QUANTITY PRICING:

Quantity pricing is valid on single shipments only.

AVAILABILITY: Our inventory is updated automatically, but there is always a possibility that an item may be unavailable or sold-out. If this occurs, customers are notified as soon as possible and alternative options are offered if available.

PACKAGING: The factory will determine the most cost effective method to package items for shipment. A \$5.00 USD per cardboard box charge will be applied to all orders with a maximum charge of \$25.00 USD per shipment. Large products requiring a wooden crate will be charged an amount consistent with the fabrication of the necessary crate.

FOB POINT: All orders ship FOB Yreka from 1967 S. Oregon, Yreka, California, 96097, USA unless quoted otherwise.

LOST OR DAMAGED ITEMS: Nor-Cal does not assume responsibility for items lost or damaged in transit, or for any direct or indirect damages incurred. Shipping damages are to be handled by the customer. Nor-Cal will provide the tracking number and contact information for the shipping company as needed. All items are purchased at the customer's risk.

EXPORTED COMMODITIES: US Export administration Regulations must be followed. Diversion contrary to US Law is prohibited.

Pricing & Dimensions

In order to meet the changing needs of our customers we periodically make design revisions in our standard product line. As a result, the dimensions, pricing and specifications are subject to change without notice. International pricing may also vary.

SPECIAL TOOLING: Products ordered to non-standard specifications should state specification requirements in detail. Fee for special tooling may apply. On request, test report(s) and/or certification(s) can be supplied at additional cost.

Discounts

OEM and quantity discounts are available to qualified customers.

Return Policy

An RMA (Return Materials Authorization) number must be obtained from Nor-Cal Products before returning any merchandise. The RMA form can be found under SUPPORT in the footer of pages at www.n-c.com. To expedite the assignment of an RMA number, complete the form online and submit online. You may also print and email the completed form to rma@n-c.com or fax to the attention of the RMA Coordinator at 866-640-9012.

- Nor-Cal Products reserves the right to refuse the return of non-stocked items. A twenty-five (25) percent restocking fee may be charged.
- Nor-Cal Products shall incur no liability for damage, shortages or other cause alleged to have occurred at, or prior to, delivery to the carrier unless buyer shall have entered full details thereof on its receipt to the carrier. Products over 60 days old from the date of shipment will not be accepted for return.
- Nor-Cal Products must be allowed time to investigate all returns.

Cancellations & Rescheduling

Any request by customers to reschedule or cancel in total or part of any purchase order must be approved at the sole discretion of Nor-Cal Products and shall be subject to the following conditions. Nor-Cal must receive written notice of Request for Cancellation or Reschedule, stating the reasons therefore.

Customer shall be liable for payment of the following charges to Nor-Cal in the event of Cancellation or Reschedule.

- For all charges incurred (including overhead, G&A, and profit) prior to the date that notice of cancellation is received by Nor-Cal for all parts peculiar to customer's requirements. Upon payment by the customer of these charges, such parts become the property of customer, Nor-Cal will store said parts for a reasonable period of time pending the receipt of customer's instructions for disposition. Such storage is at customer's risk and may be subject to storage charges if stored by Nor-Cal for longer than 30 days from the cancellation date; plus
- Charges to convert modified standard parts for return to Nor-Cal's inventory; plus
- A restocking charge of twenty (25) percent of the purchase price of the cancelled item.

Warranty Products manufactured by Nor-Cal Products are warranted against defects in material and workmanship for a period of twelve (12) months from the date of shipment from Nor-Cal Products to the buyer. Any modification to the product by the buyer or their agent voids this warranty. Liability under this warranty is expressly limited to the replacement or repair (at Nor-Cal Products' option) of defective parts. Nor-Cal Products may at any time discharge its warranty as to any of its products by refunding the purchase price and taking back the products. This warranty applies only to parts manufactured and labor provided by Nor-Cal Products under valid warranty claims received by Nor-Cal Products within the applicable warranty period and shall be subject to the terms and conditions hereof.

- Expendable items such as tubes, heaters, sources, bellows, etc., by their nature, may not function for one year; if such items fail to give reasonable service for a reasonable period of time, as determined solely by Nor-Cal Products, they will be repaired or replaced by Nor-Cal Products at its election.
- All warranty replacement or repair of parts shall be limited to equipment malfunctions which, in the sole opinion of Nor-Cal Products, are due or traceable to defects in original materials or workmanship. Malfunctions caused by abuse or neglect of the equipment are expressly not covered by this warranty. Nor-Cal Products expressly disclaims responsibility for any loss or damage caused by the use of its products other than in accordance with proper operating and safety procedures. Reasonable care must be taken by the user to avoid hazards.
- The buyer shall give Nor-Cal Products prompt notice of any claim under this warranty. If Nor-Cal Products, in its sole discretion, determines that the product does not conform to this warranty, Nor-Cal Products shall replace or repair the product free of charge. If such replacement or repair is not feasible, Nor-Cal Products may, at its sole option, refund the purchase price.
- In-warranty repaired or replacement parts are warranted only for the remaining unexpired portion of the original warranty period applicable to the parts which have been repaired or replaced.
- After the expiration of the applicable warranty period, the buyer shall be charged at Nor-Cal Products' then current prices for parts and labor plus transportation.
- Except as stated herein, Nor-Cal Products makes no warranty, expressed or implied (either in fact or operation of law), statutory or otherwise: and, except as stated herein, Nor-Cal Products shall have no liability for special or consequential damages of any kind or from any cause arising out of the sale, installation, or use of any of its products. Statements made by any person, including representatives of Nor-Cal Products, which are inconsistent or in conflict with the terms of this warranty shall not be binding upon Nor-Cal unless reduced to writing and approved by an officer of Nor-Cal Products.
- This warranty shall not extend to any product, that in Nor-Cal Products' judgment, has been affected by damage or wear resulting from operations performed after the sale, or misuse, abrasion, negligence, accident, tampering, faulty installation, inadequate maintenance, damage or casualty.

DISCLAIMER OF WARRANTY: NOR-CAL MAKES NO WARRANTIES WITH RESPECT TO THIS SALE, WHETHER EXPRESSED OR IMPLIED, EXCEPT AS STATED HEREIN, NOR-CAL PRODUCTS MAKES NO WARRANTY OF MERCHANTABILITY OR FITNESS FOR A PARTICULAR PURPOSE.

LIMITATION OF REMEDY AND DAMAGES: THE EXCLUSIVE REMEDY OF THE BUYER WITH RESPECT TO THE TRANSACTIONS CONTEMPLATED HEREIN SHALL BE THE REPLACEMENT OR REPAIR OF SAID PRODUCTS, OR THE RETURN OF THE PURCHASE PRICE, AS SET FORTH UNDER "WARRANTY".

EXCEPT AS HEREIN PROVIDED, EVERY FORM OF LIABILITY FOR DIRECT OR CONSEQUENTIAL DAMAGE FOR LOSS, ARISING FROM CONTRACT, TORT OR OTHERWISE, IS EXPRESSLY EXCLUDED AND DENIED, INCLUDING WITHOUT LIMITATION, LOSS OR DAMAGES TO BUILDINGS, CONTENTS, PRODUCTS OR PERSONS.

Order Information

Patents & Trademarks

Nor-Cal Products, Inc. patents and trademarks:

Genesis Modular Valves are manufactured under patent number 6289932

Intellisys Pressure Control Products are manufactured under patent number 6612331

Genesis is a trademark of Nor-Cal Products, Inc.

Intellisys is a registered trademark of Nor-Cal Products, Inc.

Other registered patents and trademarks:

Magnetic Linear/Rotary Feedthroughs are manufactured under patent number 5514925

Sample Transfer Systems are manufactured under patent number 5705128

Alumel is a registered trademark of Concept Alloys, Inc.

Cajon is a registered trademark of Swagelok Company

Chemraz is a registered trademark of Greene Tweed Company

Chromel is a registered trademark of Concept Alloys, Inc.

ConFlat is a registered trademark of Varian Associates Corp.

DeviceNet is a trademark of the Open DeviceNet Vendor Association (ODVA)

Dupra is a registered trademark of Daikin Industries, Ltd.

Ethernet is a trademark of Xerox Corporation

EVAC-CeFix is a registered trademark of EVAC AG

Inconel is a registered trademark of Special Metals Corp.

KF is a registered trademark of Leybold Vacuum Products Inc.

Kalrez is a registered trademark of DuPont Dow Elastomers

Kovar is a registered trademark of CRS Holdings Inc.

Macor is a registered trademark of Corning, Inc.

Microdot is a registered trademark of Tyco Electronics Corp.

Modbus is a registered trademark of Schneider Electric USA Inc.

Omicron is a registered trademark of Omicron Electric GmbH

Pendurroll is a patented technology of V-Tex Corporation

Perlast is a registered trademark of Precision Polymer Engineering LTD.

SolidWorks is a registered trademark of Dassault Systèmes SolidWorks Corp.

Swagelok is a registered trademark of Swagelok Company

UL is a registered trademark of Underwriters Laboratories, Inc.

VCR is a registered trademark of Swagelok Company

Windows is a registered trademark of Microsoft Corporation

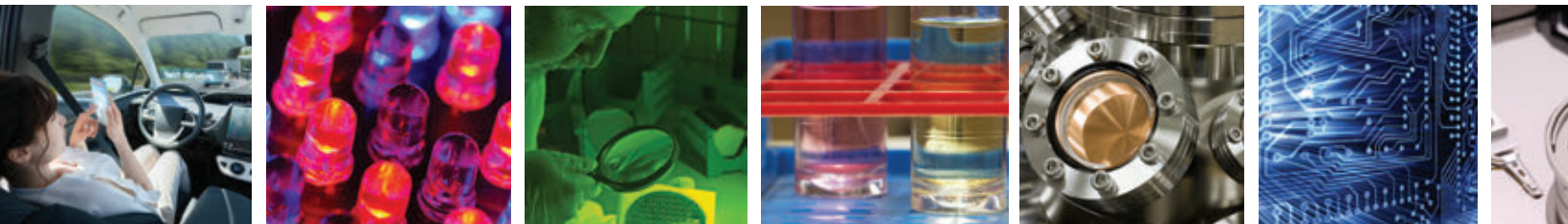

Nor-Cal Products



by PFEIFFER VACUUM

Nor-Cal Products, Inc.
1967 South Oregon Street
Yreka, California 96097
800-824-4166 or 530-842-4457
Fax: 530-841-9189
www.n-c.com