

Bayard-Alpert Pirani Gauge

FRG-720

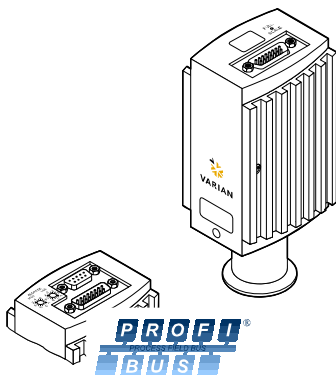

Short Operating Instructions
Incl. EC Declaration of Conformity

Product Identification

In all communications with VARIAN, please specify the information on the product nameplate. For convenient reference copy that information into the space provided below.

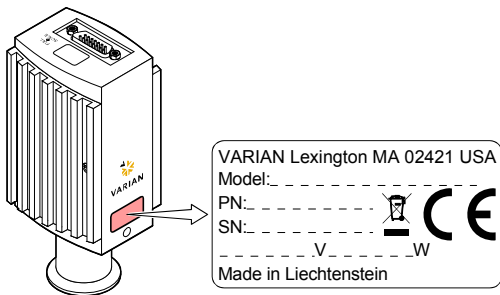

Validity

This document applies to products with part numbers

Without display

FRG720KF25	(DN 25 ISO-KF)
FRG720CF35	(DN 40 CF-R)

With display

FRG720KF25D	(DN 25 ISO-KF)
FRG720CF35D	(DN 40 CF-R)

With Profibus interface and 2 switching functions

FRG720KF25P	(DN 25 ISO-KF)
FRG720CF35P	(DN 40 CF-R)

The part number (PN) can be taken from the product nameplate.

If not indicated otherwise in the legends, the illustrations in this document correspond to the gauge with part number FRG720KF25. They apply to the other gauges by analogy.

We reserve the right to make technical changes without prior notice.

All dimensions in mm.

Intended Use

The FRG-720 gauge has been designed for vacuum measurement of gases in the pressure range of 5×10^{-10} ... 1000 mbar. It must not be used for measuring flammable or combustible gases in mixtures containing oxidants (e.g. atmospheric oxygen) within the explosion range.

The gauge can be operated in connection with a VARIAN AGC-100 Vacuum Gauge Controller, a VARIAN Turbo AG Rack Controller, or with another controller.

Functional Principle

Standard Gauge

Over the whole measuring range, the gauge has a continuous characteristic curve and its measuring signal is output as logarithm of the pressure.

The gauge functions with a Bayard-Alpert hot cathode ionization measurement system (for $p < 2.0 \times 10^{-2}$ mbar) and a Pirani measurement system (for $p > 5.5 \times 10^{-3}$ mbar). In the overlapping pressure range of 2.0×10^{-2} ... 5.5×10^{-3} mbar, a mixed signal of the two measurement systems is output. The hot cathode is switched on by the Pirani measurement system only below the switching threshold of 2.4×10^{-2} mbar (to prevent filament burn-out). It is switched off when the pressure exceeds 3.2×10^{-2} mbar.

Profibus Gauge





The Profibus gauge has a fieldbus interface that conforms to the Profibus DPV1 standard (→  [5]). Two adjustable switching functions are integrated in the gauges. The corresponding relay contacts are available at the sensor cable connector.

The basic sensor and sensor electronics of the Profibus gauge are the same as in the standard FRG-720.

Contents

Product Identification	2
Validity	2
Intended Use	3
Functional Principle	3
1 Safety	6
1.1 Symbols Used	6
1.2 Personnel Qualifications	6
1.3 General Safety Instructions	7
1.4 Liability and Warranty	7
2 Technical Data	8
3 Installation	16
3.1 Vacuum Connection	16
3.2 Power Connection	19
3.3 Profibus Cable Connection	22
4 Operation	23
4.1 Gas Type Dependence	23
4.2 Display	24
4.3 Profibus Interface	25
4.4 Switching Function Profibus Gauge	26
5 Deinstallation	28
6 Maintenance, Repair	30
6.1 Adjustment at Atmospheric Pressure	30
6.2 Zero Point Adjustment	33
7 Returning the Product	34
8 Disposal	35
Further Information	36
EC Declaration of Conformity	37

For cross-references within this document, the symbol (→  XY) is used, for cross-references to further documents, listed under further information, the symbol (→  [Z]).

1 Safety

1.1 Symbols Used



DANGER

Information on preventing any kind of physical injury.



WARNING

Information on preventing extensive equipment and environmental damage.



Caution

Information on correct handling or use. Disregard can lead to malfunctions or minor equipment damage.

1.2 Personnel Qualifications



Skilled personnel

All work described in this document may only be carried out by persons who have suitable technical training and the necessary experience or who have been instructed by the end-user of the product.

1.3 General Safety Instructions

- Adhere to the applicable regulations and take the necessary precautions for the process media used.
Consider possible reactions between the materials and the process media.
Consider possible reactions (e.g. explosion) of the process media due to the heat generated by the product.
- Adhere to the applicable regulations and take the necessary precautions for all work you are going to do and consider the safety instructions in this document.
- Before beginning to work, find out whether any vacuum components are contaminated. Adhere to the relevant regulations and take the necessary precautions when handling contaminated parts.

Communicate the safety instructions to all other users.

1.4 Liability and Warranty

VARIAN assumes no liability and the warranty becomes null and void if the end-user or third parties

- disregard the information in this document
- use the product in a non-conforming manner
- make any kind of interventions (modifications, alterations etc.) on the product
- use the product with accessories, not listed in the corresponding product documentation.

The end-user assumes the responsibility in conjunction with the process media used.

Gauge failures due to contamination or wear and tear as well as expendable parts (filament) are not covered by the warranty.

2 Technical Data

Measurement

Measurement range (air, O ₂ , CO, N ₂)	5×10 ⁻¹⁰ ... 1000 mbar continuous
Accuracy (after 5 min. stabilization)	15% of reading in the range 1×10 ⁻⁸ ... 10 ⁻² mbar
Repeatability (after 5 min. stabilization)	5% of reading in the range 1×10 ⁻⁸ ... 10 ⁻² mbar

Emission

Switching on threshold	2.4×10 ⁻² mbar
Switching off threshold	3.2×10 ⁻² mbar
Emission current p ≤ 7.2×10 ⁻⁶ mbar	5 mA
7.2×10 ⁻⁶ mbar < p < 3.2×10 ⁻² mbar	25 μA
Emission current switching 25 μA ⇒ 5 mA	7.2×10 ⁻⁶ mbar
5 mA ⇒ 25 μA	3.0×10 ⁻⁵ mbar

Degas

Current (p < 7.2×10 ⁻⁶ mbar)	≈ 16 mA (P _{degas} ≈ 4.0 W)
Control input signal	0 V/+24 VDC, high active
Duration	< 3 min. followed by automatic deactivation.

In degas mode, the gauge keeps supplying pressure readings, the tolerances of which can be higher than during normal operation.

Output signal

Output signal (measuring signal)	0 ... +10 V
Measuring range	+0.774 ... +10 V (5×10^{-10} ... 1000 mbar)
Voltage vs. pressure	logarithmic, 0.75 V/decade
Error signal (→  [1])	
Hot cathode error	≈+0.3 VDC
Pirani error	≈+0.5 VDC
Minimum loaded impedance	10 kΩ



Identification

Gauge identification	42 kΩ between Pin 10 and Pin 5 (sensor cable)
----------------------	--

Switching Functions (Profibus gauge only)

Number	2 (setpoints A and B)
Adjustment range	1×10^{-9} ... 100 mbar adjustable via potentiometers, one floating, normally open relay contact per setpoint
Hysteresis	10% of the threshold value
Relay contact rating	
Voltage	≤60 VDC
Current	≤0.5 ADC

RS232C Interface







Data rate	9600 Baud
Data format	binary, 8 data bits, one stop bit, no parity bit, no handshake
Connector	
Standard gauge	→  19
Profibus gauge	→  20

Further information on the RS232C interface →  [1].

Profibus Interface

(Profibus gauges only)





Standard applied	→  [5]
Communication protocol, Data format	→  [2], [5]
Interface, physical	RS485
Data rate	≤12 MBaud, →  [2], [5]
Node address	00 ... 7D _{hex} (0 ... 125 _{dec})
Connection	D-Sub, 9-pin, female, →  22
Cable	shielded, special Profibus cable, →  [3], [5]
Cable length, system wiring	according to Profibus specifications, →  [3], [5]

Display (part no. FRG720KF25D and FRG720CF35D only)

Display panel	LCD matrix, 32×16 pixels, with background illumination
Dimensions	16.0 mm × 11.2 mm
Pressure unit	mbar (default), Torr, Pa
Changing the pressure unit	via RS232C, →  [1]

Supply







DANGER



The gauge may only be connected to power supplies, instruments or control devices that conform to the requirements of a grounded extra low voltage (SELV). The connection to the gauge has to be fused. ¹⁾

¹⁾ VARIAN controllers fulfill these requirements.

Voltage at the gauge	+24 VDC (+20 ... +28 VDC), (Ripple $\leq 2 V_{pp}$) ²⁾
Power consumption	
Standard	≤ 0.5 A
Degas	≤ 0.8 A
Emission start (200 ms)	≤ 1.4 A
Fuse required ¹⁾	1.25 AT
Power consumption	
Standard gauge	≤ 16 W
Profibus gauge	≤ 18 W

Electrical Connection

Connection	D-Sub, 15-pin, male
Standard gauge	→  19
Profibus gauge	→  20
Sensor cable	
For analog values only, without degas function	4 conductors plus shielding
For analog values, with degas function	5 conductors plus shielding
All functions, incl. RS232C interface	7 conductors plus shielding
Profibus gauge	depending on the functions used, max. 15 conductors plus shielding
Cable length (24 VDC)	≤ 35 m (0.25 mm ² / conductor) ≤ 50 m (0.34 mm ² / conductor) ≤ 100 m (1.0 mm ² / conductor)
For RS232C operation	≤ 30 m

Grounding concept	
Standard gauge	→  19
Profibus gauge	→  20

²⁾ Consider the voltage drop as function of the sensor cable length.

Materials Exposed to Vacuum

Housing, supports, screens	stainless steel
Feedthroughs	NiFe, nickel plated
Insulator	glass
Cathode	iridium, yttrium oxide (Y ₂ O ₃)
Cathode holder	molybdenum, platinum
Pirani element	tungsten, copper

Internal volume	
DN 25 ISO-KF	≈24 cm ³
DN 40 CF-R	≈34 cm ³
Admissible pressure max.	2 bar (absolute)

Ambient

Admissible temperatures	
Storage	-20 ... +70 °C
Operation	0 ... +50 °C
Bakeout	+80 °C ³⁾
Tube extension	+150 °C ³⁾

Relative humidity	
Year's mean	≤65% (no condensation)
During 60 days	≤85% (no condensation)
Use	indoors only altitude up to 2000 m NN
Mounting orientation	any
Degree of protection	IP 30

³⁾ Flange temperature, horizontally mounted, without electronics.

Dimensions [mm]

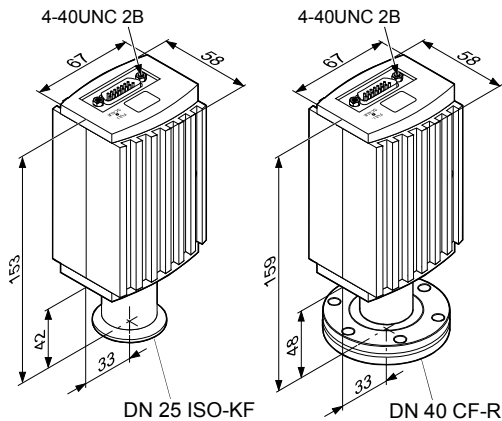

Weight

FRG720KF25, FRG720KF25D	≈285 g
FRG720CF35, FRG720CF35D	≈550 g
FRG720KF25P	≈430 g
FRG720CF35P	≈695 g

Measurement Signal vs. Pressure

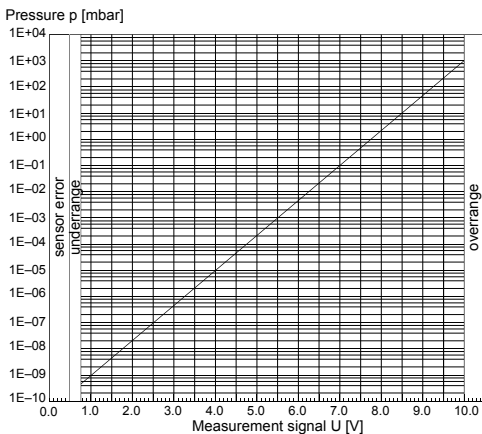

$$p = 10^{(U-7.75)/0.75+c}$$

U	p	c
[V]	[mbar]	0
[V]	[Pa]	2
[V]	[Torr]	-0.125

where

- p pressure
- U measurement signal
- c constant (depending on pressure unit)

Gas Type Dependence

For gases other than air, the pressure reading in the range $p < 10^{-3}$ mbar can be converted by means of the following formula:

$$p_{\text{eff}} = C \times \text{pressure reading}$$

Gas type	Calibration factor C	Gas type	Calibration factor C
He	5.9	air, O ₂ , CO, N ₂	1.0
Ne	4.1	H ₂	2.4
Kr	0.5	Xe	0.4
Ar	0.8		

3 Installation

3.1 Vacuum Connection



DANGER

DANGER: overpressure in the vacuum system
>1 bar

Injury caused by released parts and harm caused by escaping process gases can result if clamps are opened while the vacuum system is pressurized.

Do not open any clamps while the vacuum system is pressurized. Use the type of clamps which are suited to overpressure.



DANGER

DANGER: line voltage

Products that are not professionally connected to ground can be extremely hazardous in the event of a fault.

The gauge must be electrically connected to the grounded vacuum chamber. This connection must conform to the requirements of a protective connection according to EN 61010:

- CF connections fulfill this requirement.
- For gauges with KF connection, use a conductive metallic clamping ring.



Caution



Caution: vacuum component

Dirt and damages impair the function of the vacuum component.

When handling vacuum components, take appropriate measures to ensure cleanliness and prevent damages.



Caution



Caution: dirt sensitive area

Touching the product or parts thereof with bare hands increases the desorption rate.

Always wear clean, lint-free gloves and use clean tools when working in this area.



The gauge may be mounted in any orientation. To keep condensates and particles from getting into the measuring chamber preferably choose a horizontal to upright position.

The gauge is supplied with a built-in grid. For potentially contaminating applications and to protect the electrodes against light and fast charged particles, installation of the optional baffle is recommended (→  [1]).



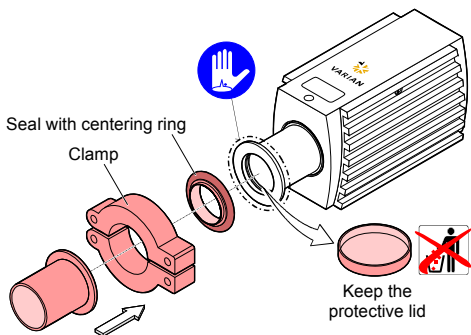

Vacuum connection must be free of grease.

Remove the protective lid and install the product to the vacuum system.



3.2 Power Connection

 Make sure the vacuum connection is properly made (→  16).

1 If no sensor cable is available, make one according to the following diagram.

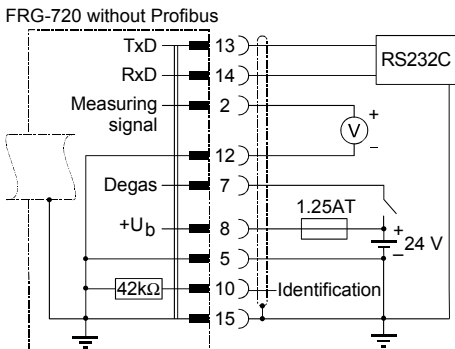

Electrical connection

- Pin 2 Signal output (measuring signal) 0 ... +10 V
- Pin 5 Supply common, GND
- Pin 7 Degas on, active high +24 VDC
- Pin 8 Supply +24 VDC
- Pin 10 Gauge identification
- Pin 12 Signal common, GND
- Pin 13 RS232C, TxD
- Pin 14 RS232C, RxD
- Pin 15 Shielding, housing, GND

Pins 1, 3, 4, 6, 9 and 11 are not connected internally.

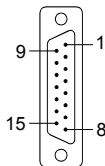

D-Sub, 15-pin female, soldering side

FRG-720 with Profibus

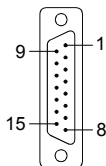
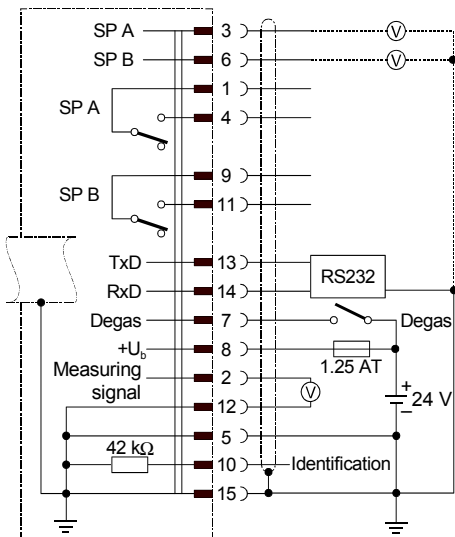

D-Sub, 15-pin female,
soldering side

Electrical connection

- Pin 1 Relay Switching function A, COM contact
- Pin 2 Signal output (measuring signal) 0 ... +10 V
- Pin 3 Threshold value (Setpoint) A, 0 ... +10 V
- Pin 4 Relay Switching function A, N.O. contact
- Pin 5 Supply common, GND
- Pin 6 Threshold value (Setpoint) B, 0 ... +10 V
- Pin 7 Degas on, active high +24 V
- Pin 8 Supply voltage +24 V
- Pin 9 Relay Switching function B, COM contact
- Pin 10 Gauge identification
- Pin 11 Relay Switching function B, N.O. contact
- Pin 12 Signal common GND
- Pin 13 RS232, TxD
- Pin 14 RS232, RxD
- Pin 15 Shielding, housing GND

- 2** Connect the sensor cable to the gauge.
- 3** Secure the cable connector with the lock screws and connect the sensor cable to the controller.

3.3 Profibus Cable Connection

- 1** If no Profibus cable is available, make one according to the following indications:

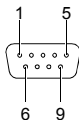

D-Sub, 9-pin,
male, soldering side



Pin 1	Do not connect
Pin 2	Do not connect
Pin 3	RxD/TxD-P
Pin 4	CNTR-P ⁴⁾
Pin 5	DGND ⁵⁾
Pin 6	VP ⁵⁾
Pin 7	Do not connect
Pin 8	RxD/TxD-N
Pin 9	Do not connect

- 2** Connect the Profibus cable to the gauge and secure the cable socket to the gauge with the lock screws.

⁴⁾ Only to be connected if an *optical link* module is used.

⁵⁾ Only required as line termination for devices at the ends of bus system (→  [5]).



4 Operation

When the supply voltage is applied, the measurement signal is available between pins 2 (+) and 12 (-) (relationship between measurement signal and pressure →  14 and  [1]).

The Profibus gauge can also be operated via the corresponding fieldbus interface (Profibus) (→  [1] for details and further functions).

Allow for a stabilizing time of ≈ 10 minutes. Once the gauge has been switched on, permanently leave it on irrespective of the pressure.

4.1 Gas Type Dependence

The measurement value is gas type dependent. The pressure reading applies to dry air, O₂, CO and N₂. For other gases, it has to be converted (→  15 and  [1]).

4.2 Display

(part no. FRG720KF25D and FRG720CF35D only)

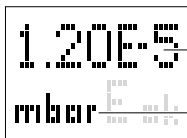

Pressure reading

Pressure unit

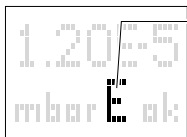

Function display

- (non) Pirani operation
- E Emission 25 μ A
- E. Emission 5 mA
- D Degas
- A 1000 mbar adjustment (Pirani)

Error Display

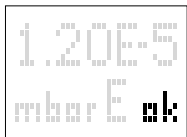

- 0k no error (green background illumination)
- 5 Pirani sensor warning (red background illumination)
- 9 Pirani sensor error (red background illumination)



- 8 BA sensor error (red background illumination)

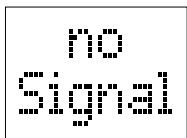

Internal data connection failure (red background illumination)

4.3 Profibus Interface

(part no. FRG720KF25P and FRG720CF35P only)



Caution



Caution: data transmission errors
 If the gauge is operated with the RS232 and Profibus interfaces at the same time, data transmission errors may occur.

The gauge must not be operated with the RS232 and the Profibus interfaces at the same time.

Operating Software

For operating the gauge via Profibus, prior installation of the gauge specific GSD file is required on the bus master side (controller, PLC). This file can be downloaded under www.varianinc.com.

Setting the Device Address "ADDRESS"

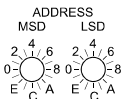

The node address (0 ... 125_{dec}) is set in hexadecimal form (00 ... 7D_{hex}) via the "ADDRESS", "MSD", and "LSD" switches. The node address is polled by the firmware when the gauge is switched on. If the setting deviates from the stored value, the new value is taken over into the NVRAM. If a value >125_{dec} (>7D_{hex}) is entered, the node address setting currently stored in the device remains valid but it can now be defined via Profibus ("Set slave Address", →  [2]).



The factory setting of the device address is 5C_{hex}.

The device address setting can also be made via Profibus (→  [2]).

4.4 Switching Function Profibus Gauge

The threshold values of switching functions A and B can be set within the pressure range 1×10^{-9} mbar ... 100 mbar via potentiometers "SETPOINT A" and "SETPOINT B". For the corresponding threshold voltages $U_{\text{Threshold}}$, the following equation applies:

$$U_{\text{Threshold}} = 0.8129401 \times (\log p_{\text{Setpoint}} - c + 9.30102999)$$

Constant c depends on the pressure unit (\rightarrow  14 and \rightarrow  [1]).

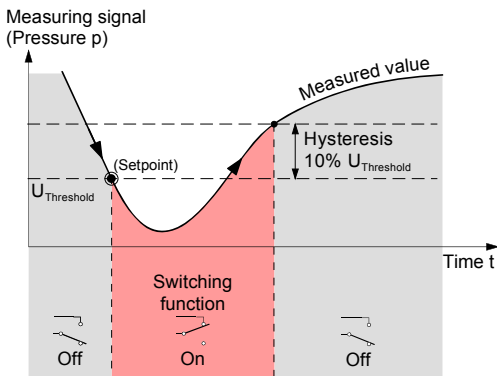

The hysteresis of the switching functions is 10% of the threshold setting.

- 1** Put the gauge into operation.
- 2** Connect the +lead of a voltmeter to the threshold measurement point of the selected switching function ("Setpoint A" Pin 3, "Setpoint B" Pin 6) and its -lead to Pin 5.

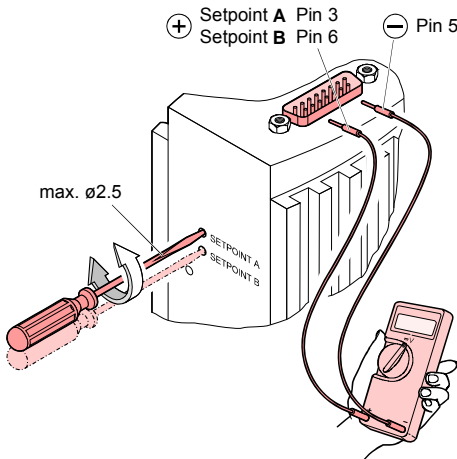

- 3** Using a screwdriver (max. $\varnothing 2.5$ mm), set the threshold of the selected switching function (Setpoint A, B) to the desired value $U_{\text{Threshold}}$.

A functional check of the switching functions (On/Off) is only possible via fieldbus interface (\rightarrow  [2] for Profibus gauge) or by measuring the relay contacts with a continuity checker/ohmmeter (\rightarrow "Power Connection", sensor cable connector).

5 Deinstallation

 **DANGER**

DANGER: contaminated parts

Contaminated parts can be detrimental to health and environment.

Before beginning to work, find out whether any parts are contaminated. Adhere to the relevant regulations and take the necessary precautions when handling contaminated parts.

 **Caution**

Caution: vacuum component

Dirt and damages impair the function of the vacuum component.

When handling vacuum components, take appropriate measures to ensure cleanliness and prevent damages.

 **Caution**

Caution: dirt sensitive area

Touching the product or parts thereof with bare hands increases the desorption rate.

Always wear clean, lint-free gloves and use clean tools when working in this area.

- 1** Vent the vacuum system.
- 2** Put the gauge out of operation.

- 3 Unfasten the lock screws and unplug the cable socket (and also the interface cable at Profibus gauge).
- 4 Remove the gauge from the vacuum system and put the protective lid in place.

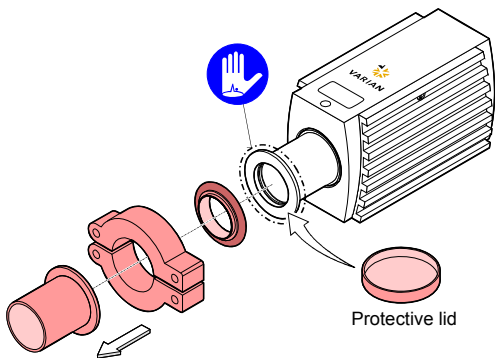

6 Maintenance, Repair

In case of severe contamination or a malfunction, the sensor can be replaced (→  [1]).



Gauge failures due to contamination or wear and tear as well as expendable parts (filaments) are not covered by the warranty.

6.1 Adjustment at Atmospheric Pressure

The gauge is factory calibrated. If used under different climatic conditions, at extreme temperatures, through aging or contamination and after exchanging the sensor, the characteristic curve can be offset and readjustment can become necessary. Only the Pirani element can be adjusted and only at atmosphere.

Readjustment becomes necessary if

- at atmosphere, the output voltage is $< +10$ V
- the display reads $<$ atmospheric pressure (if the gauge has a display)
- at atmosphere, the digital value at the RS232C interface is $<$ atmospheric pressure
- at atmosphere, the digital value received by the bus controller of the fieldbus gauges (Profibus) is $<$ atmospheric pressure
- when venting the vacuum system, the output voltage reaches 10 V before the measured pressure has reached atmosphere (gauges with display will show the error "5" at atmosphere (Pirani sensor warning)).
- when the vacuum system is vented, the digital value of the RS232C interface reaches its maximum before the measured pressure has reached atmosphere
- when the vacuum system is vented, the digital value received by the bus controller of the Profibus reaches its maximum before the measured pressure has reached atmosphere.

Standard Gauge

- 1 If you are using a seal with centering ring and filter, check that they are clean or replace them if necessary (→  [1] "Deinstallation").
- 2 Put the gauge into operation.



Operate the gauge for ≈ 10 minutes at atmospheric pressure. If the gauge was operated within the BA range, a cooling-down time of ≈ 30 minutes is to be expected (gauge temperature = environmental temperature).

- 3 Adjusting the gauge

Gauge without display

Gauge with display

Insert a pin ($\approx \varnothing 1.3 \times 50$ mm) through the opening marked <FULL SCALE> and push the button for at least 5 seconds.

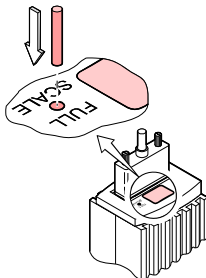
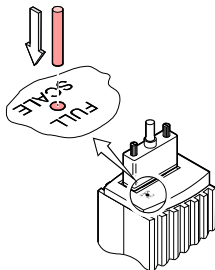



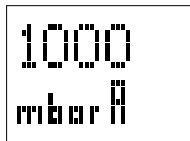

Automatic adjustment

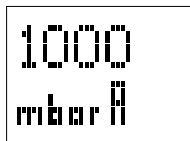

Adjustment completed



Profibus Gauge

- 1 If you are using a seal with centering ring and filter, check that they are clean or replace them if necessary (→  [1] "Deinstallation").
- 2 Put the gauge into operation.



Operate the gauge for ≈10 minutes at atmospheric pressure. If the gauge was operated within the Ioni range, a cooling-down time of ≈30 minutes is to be expected (gauge temperature = environmental temperature).

- 3 Push the button for at least 5 seconds.

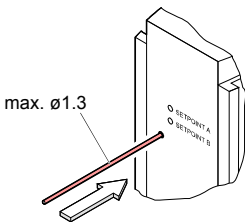

The gauge is now automatically adjusted. The adjustment takes ≈ 4 s.

6.2 Zero Point Adjustment

A zero point adjustment is recommended

- after the sensor has been exchanged
- if display shows "FAIL 5"
- as part of the usual maintenance work for quality assurance

The push button used for the adjustment at atmospheric pressure is also used for the zero point adjustment

- 1 Operate gauge for approx. 10 minutes at a pressure of $\leq 1 \times 10^{-4}$ mbar.
- 3 Push the button for at least 2 seconds.



The adjustment is done automatically and ends after 2 minutes.

7 Returning the Product



WARNING



WARNING: forwarding contaminated products
Contaminated products (e.g. radioactive, toxic, caustic or biological hazard) can be detrimental to health and environment.

Products returned to VARIAN should preferably be free of harmful substances. Adhere to the forwarding regulations of all involved countries and forwarding companies and enclose a duly completed declaration of contamination.

Products that are not clearly declared as "free of harmful substances" are decontaminated at the expense of the customer. Products not accompanied by a duly completed declaration of contamination are returned to the sender at his own expense.

8 Disposal

 **DANGER**

DANGER: contaminated parts

Contaminated parts can be detrimental to health and environment.

Before beginning to work, find out whether any parts are contaminated. Adhere to the relevant regulations and take the necessary precautions when handling contaminated parts.

 **WARNING**

WARNING: substances detrimental to the environment

Products or parts thereof (mechanical and electric components, operating fluids etc.) can be detrimental to the environment.







Dispose of such substances in accordance with the relevant local regulations.

Separating the Components

After disassembling the product, separate its components according to the following criteria:

- Contaminated components
Contaminated components (radioactive, toxic, caustic or biological hazard etc.) must be decontaminated in accordance with the relevant national regulations, separated according to their materials, and disposed of.
- Other components
Such components must be separated according to their materials and recycled.

Further Information

-  [1] www.varianinc.com
Instruction Manual
Bayard-Alpert Pirani Gauge FRG-720
tqna03e1
Varian Vacuum Technologies, Lexington, MA 02421,
USA
-  [2] www.varianinc.com
Communication Protocol
Profibus FRG-720
tqra33e1
Varian Vacuum Technologies, Lexington, MA 02421,
USA
-  [3] www.profibus.com
Profibus User Organization
-  [4] www.profibus.com
Profibus Profile Guidelines
Part 1 - Identification & Maintenance Functions
-  [5] IEC 61158 Type 3 elements: Industrial communication
networks – Fieldbus specifications
IEC 61784: Industrial communication networks –
Fieldbus profiles
-  [6] www.varianinc.com
Instruction Manual
AGC-100 Vacuum Gauge Controller
tqnb01e1
Varian Vacuum Technologies, Lexington, MA, 02421
USA

EC Declaration of Conformity



We, VARIAN, hereby declare that the equipment mentioned below complies with the provisions of the Directive relating to electromagnetic compatibility 2004/108/EC.

Products

Bayard-Alpert Pirani Gauge

FRG-720

Standards

Harmonized and international/national standards and specifications:

- EN 61000-6-2:2005 (EMC: generic immunity standard)
- EN 61000-6-3:2007 (EMC: generic emission standard)
- EN 61010-1:2001 (Safety requirements for electrical equipment for measurement, control and laboratory use)
- EN 61326:2006 (EMC requirements for electrical equipment for measurement, control and laboratory use)

Manufacturer / Signature

Varian Vacuum Technologies, 121 Hartwell Avenue, Lexington, MA, 02421 USA

19 May 2010



John Ehmann
General Manager

Notes

Notes



t q ma 0 3 e 1

VARIAN 
vacuum technologies

121 Hartwell Avenue
Lexington, MA, 02421 USA
Tel: (781) 861 7200
Fax: (781) 861 5437
custserv@varianinc.com

www.varianinc.com