

87-900-843-01

June 1992

Instruction Manual



Turbo-V80 pumps

Model 969-9017

Model 969-9018

Model 969-9019

away

C

()

C

Table of Contents

Section		Page
-	Safety summary	ii
<hr/>		
I	Description	
<hr/>		
1-1	General	1-1
1-2	Turbo-V80 pump description	1-1
1-2.1	TurboV-80 pump specifications	1-2
1-2.2	TurboV-80 pump outline	1-4
<hr/>		
II	Installation & Operation	
<hr/>		
2-1	Turbo-V80 pump inspection	2-1
2-2	Turbo-V80 pump installation	2-1
2-2.1	Oil fill	2-1
2-2.2	Typical Turbo-V pump interconnections	2-2
2-2.3	High-vacuum flange connection	2-2
2-2.4	Forepump connection	2-3
2-2.5	Vent valve connection	2-3
2-2.6	Water-cooling connection	2-3
2-2.7	Electrical connection	2-3
2-3	General operation	2-4
2-4	Bakeout procedure	2-4
<hr/>		
III	Maintenance & Spare parts	
<hr/>		
3-1	General	3-1
3-2	Turbo-V80 pump maintenance	3-1
3-2.1	Oil change	3-1
3-2.2	Cleaning	3-1
3-2.3	Bearing replacement	3-2
3-3	Accessories	3-3

SAFETY SUMMARY

Operators and service personnel must be aware of all hazards associated with this equipment. They must know how to recognize hazardous and potentially hazardous conditions, and know how to avoid them. The consequences of unskilled, improper, or careless operation of the equipment can be serious. This product must only be operated and maintained by trained personnel. Every operator or service person must read and thoroughly understand operation/maintenance manuals and any additional information provided by Varian. All warnings and cautions should be read carefully and strictly observed. Address any safety, operation, and/or maintenance questions to your nearest Varian office.

The following format is used in this manual to call attention to hazards:

WARNING

Warnings are used when failure to observe instructions or precautions could result in injury or death.

CAUTION

Cautions are used when failure to observe instructions could result in damage to equipment, whether Varian-supplied or other associated equipment.

NOTE

Information to aid the operator in obtaining the best performance from the equipment.

1-1 General

The Turbo-V80 pump is a turbomolecular pump suitable for a variety of vacuum applications. It evacuates chambers from atmosphere to the 10^{-9} mbar (Torr) range when backed by a two-stage mechanical pump.

It features high pumping speeds for all gases, especially heavy hydrocarbon molecules, and vapours. The mechanical structure of the pump rotor and bearings makes it resistant to accidental air inrushes. The pump is powered by the Turbo-V80 controller, a solid-state frequency converter with control features for automatic operation with other system components.

On request, a rotary frequency converter is available to power the pump in lieu of the solid-state frequency converter and is recommended for use in environments where radiation is present, such as particle accelerators, etc. Figure 1-1 is a picture of the Turbo-V80 pump.

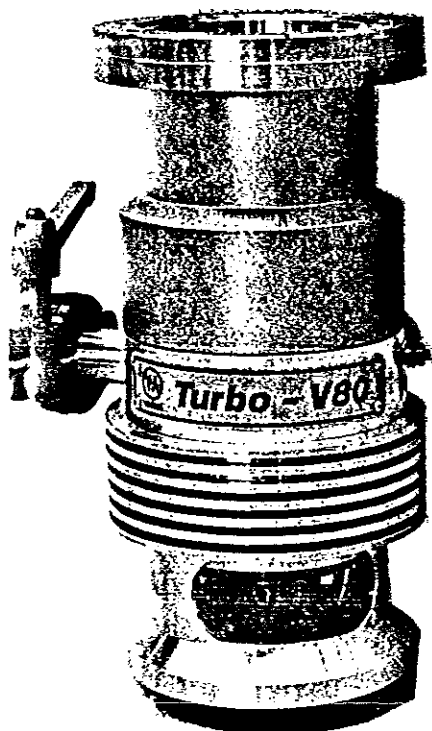

Figure 1-1 - Turbo-V80 pump

1-2 Turbo-V80 pump description

The Turbo-V80 pump is available with the following inlet flanges:

- Model 969-9017
with an ISO-100 high-vacuum flange.
- Model 969-9018
with a 6" O.D. ConFlat[®] UHV flange.
- Model 969-9019
with a 4" ANSI high-vacuum flange.

The Turbo-V80 pump incorporates a medium-frequency electric motor which drives the rotor turbine counterclockwise as observed through the inlet flange. The rotor has 12 bladed stages and achieves a speed of about 215 m/sec at the tip of the blades. The motor operates at 54 volts, 1000 Hz. It starts with a frequency ramp with a higher voltage-to-frequency ratio in order to minimize slip losses during the starting stage.

A water integrated device surrounds the pump stator and is used to cool the oil and the motor, which operates in the forevacuum region of the pump.

Thermistor sensors are mounted directly on the motor stator and pump body to prevent excessive temperatures.

The motor stator and the thermistors are wired to a 5-pin socket which accepts the pump power cable.

The turbine is made of 12 high resistance light alloy disks with the blades machined from the solid disk. The first three high vacuum stages have blade angles of 40°, while the four intermediate stages have blade angle of 30° and the lower stages in the forevacuum region have blade angles of 20°.

The turbine rotor is supported on high-precision ball bearings located on the forevacuum side of the pump and lubricated by a synthetic oil.

The pump is balanced after assembly with a residual vibration amplitude below 0.02 micrometers. Any disassembly of the turbine causes a partial loss in balance; the pump may need to be balanced again.

The stator blades are half-disks and are held in place by spacers that together support the entire stator assembly.

Lubrication is supplied by Varian T.A. oil. On request, Varian can supply pumps specially prepared for lubrication with Fomblin fluorinated fluid. It is strongly recommended not to mix different oils due to the lack of compatibility.

The oil is centrifugally pumped from the conical nose of the shaft into the pump and is ejected above the upper bearing. As it falls, it lubricates and cools the bearing, and finally draining back to the transparent oil sump where any particulates are filtered by either the magnet or the small metering hole in the sump.

The pump must be mounted vertically, with a maximum allowable slope of 10°. It can be suspended by the inlet flange or rest upon its support pedestal.

An NW 16 KF flange is provided for the foreline manifold.

Cooling water is connected to the pump via two riffled nozzles on the cooling device.

20 l/s = 0.09 GPM

1-2.1 TurboV-80 pump specifications

High vacuum flange: - ConFlat® - ISO - ANSI	4 1/2" O.D. 63 (nominal diameter) 2"
Forevacuum flange Vent port flange	NW 16 KF NW 10 KF
Pumping speed for: - N ₂ - He - H ₂	75 l/s (refer to fig. 1-2) 55 l/s 45 l/s
Base pressure*	(refer to fig. 1-3) 1 x 10 ⁻⁹ mbar (8 x 10 ⁻¹⁰ Torr)
Compression ratio for: - N ₂ - He - H ₂	3 x 10 ⁶ 5 x 10 ² 100
Recommended fore-pump:	Varian SD 90 (4.5 m ³ /h) (3.2 CFM)
Start-up time	25 seconds
Operating: - Position - Voltage - Frequency - Ambient temperature	Vertical (max slope 10°) 54 Vac ±15% - 3 phase 1000 Hz ± 2% 20°C ± 15°C
Nominal speed	60,000 rpm
Max bakeout temperature	120°C at high-vacuum flange
Noise level	≤50 DB (A) at 1 meter
Water-cooled: - Flow rate - Temperature - Pressure	? 20 l/s (0.09 GPM) + 10°C to 25°C 2 to 4 mbar (30 to 60 Psig)
Lubricant: - type - charge	Varian T.A. oil (Fomblin on request) 35 cm ³
Storage temperature	-20°C to 70°C
Weight	5.2 Kg (11.5 lbs)

* According to DIN 28 428, the base pressure is the pressure measured in the test dome 48 hours after bake-out using the ConFlat flanged Turbopump with the recommended forepump.

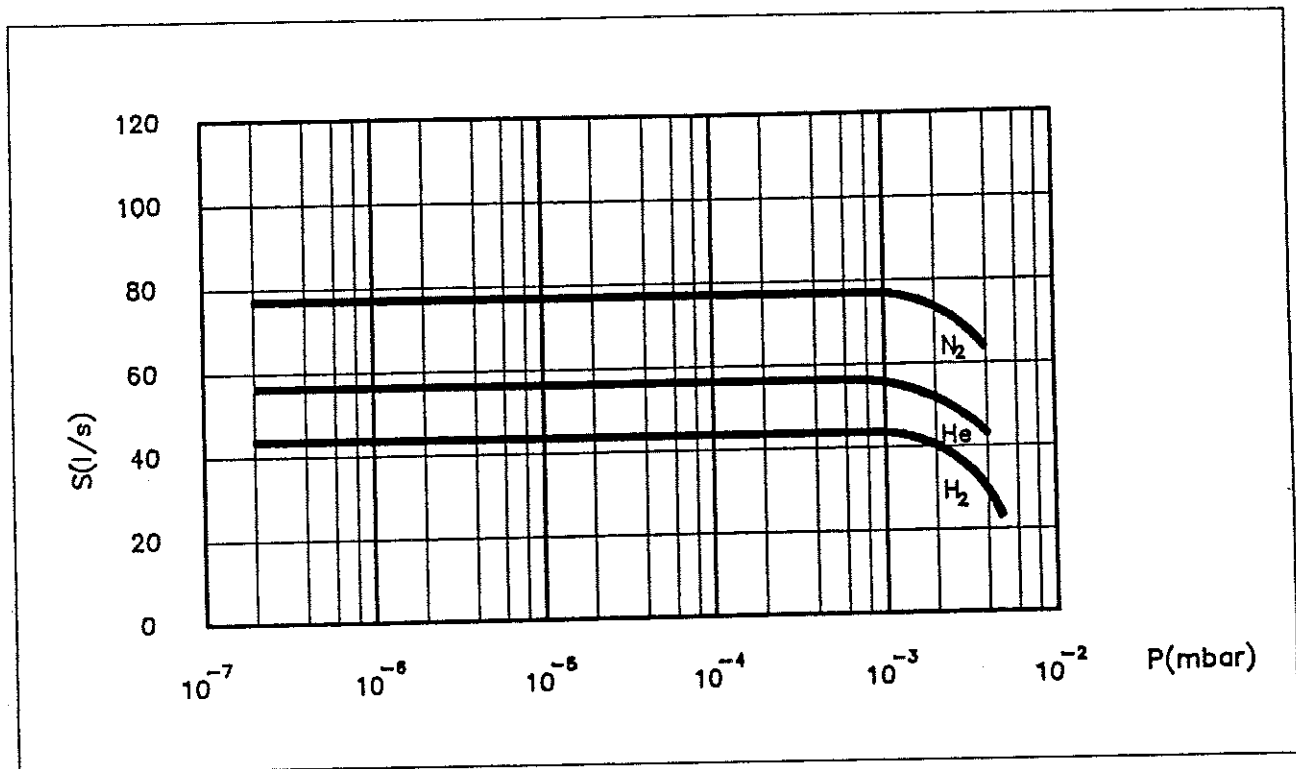

Figure 1-2 - Pumping speed vs inlet pressure

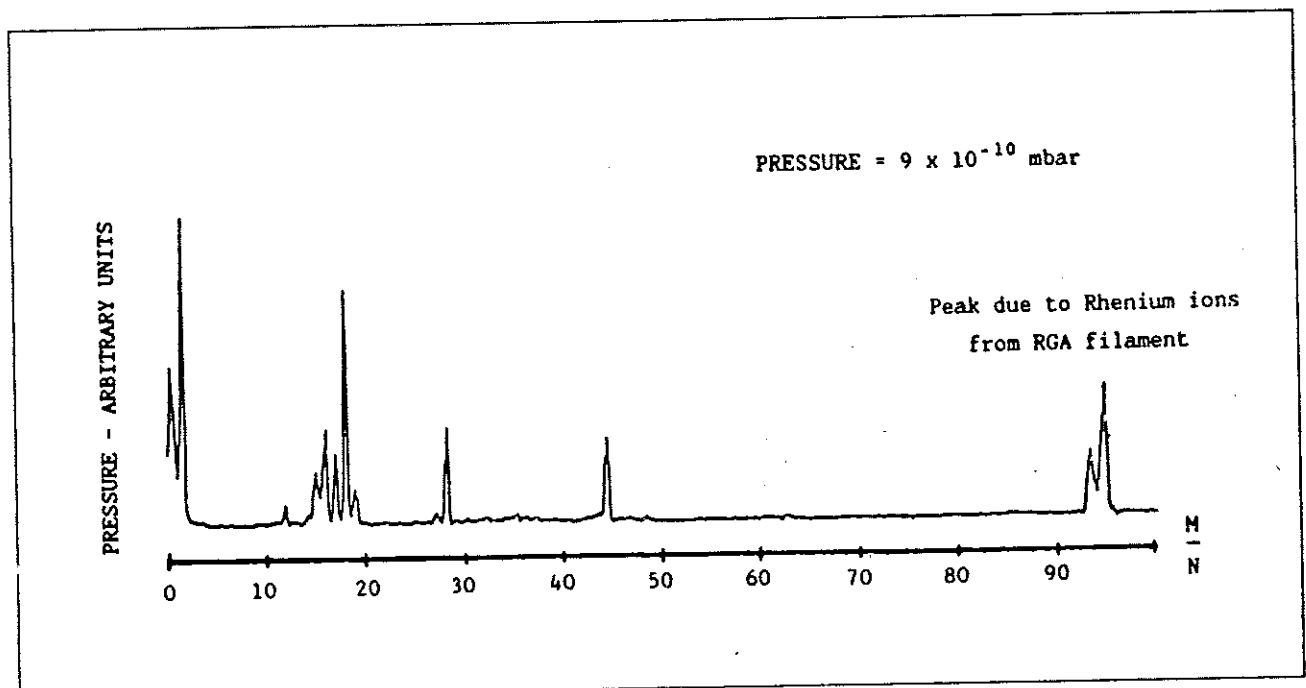

Figure 1-3 - Typical residual gas spectrum
for an unbacked system

1-2.2 TurboV-80 pump outline

The outline dimensions for the TurboV-80 are shown in figure 1-4.

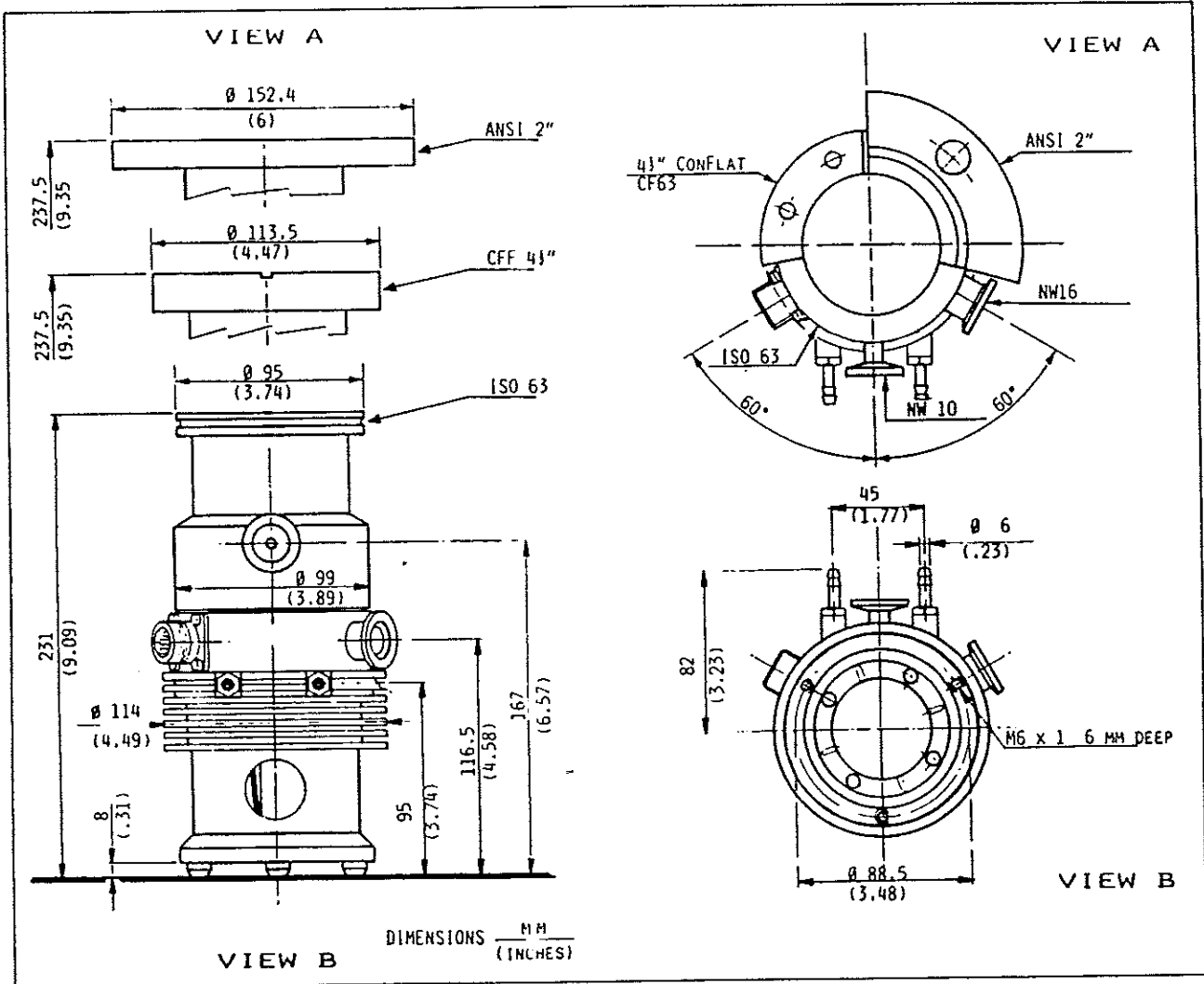

Figure 1-4 - TurboV-80 pump outline

2-1 Turbo-V80 pump inspection

The Turbo-V80 pump is shipped with the oil packaged separately to avoid contamination. The packaging of the Turbo-V80 pump is designed to minimize the possibility of shipping damages.

Take care when unpacking to avoid dropping or jarring the pump.

NOTE

The pump is not harmed by exposure to atmospheric pressure although it is good vacuum practice to keep it sealed until it is installed on the system.

CAUTION

Avoid handling parts exposed to high vacuum with bare fingers. Always use gloves or other protection to avoid pump contamination.

2-2 Turbo-V80 pump installation

2-2.1 Oil fill

Prior to installation of the pump, the oil sump must be filled with oil.

- a) Remove the four socket screws at the bottom of the pump and detach the empty oil sump.
- b) Check the cleanliness of the sump, then fill it with the recommended oil up to the marked level.

NOTE

The oil level will be lower than the OIL mark when the pump is in operation.

- c) Insert the magnet in the outer annulus of the sump (fig. 2-1).
- d) Place the O-ring into the seat and reattach the sump immediately to avoid particulate contamination of the oil. Do not overtighten the screws to prevent breakage of the plastic flange.

NOTE

When the pump is first operated with a new charge of oil, for some minutes after starting a foam formation due to outgassing will be visible through the oil sump. After several minutes the oil will become clear and will drip back into the sump.

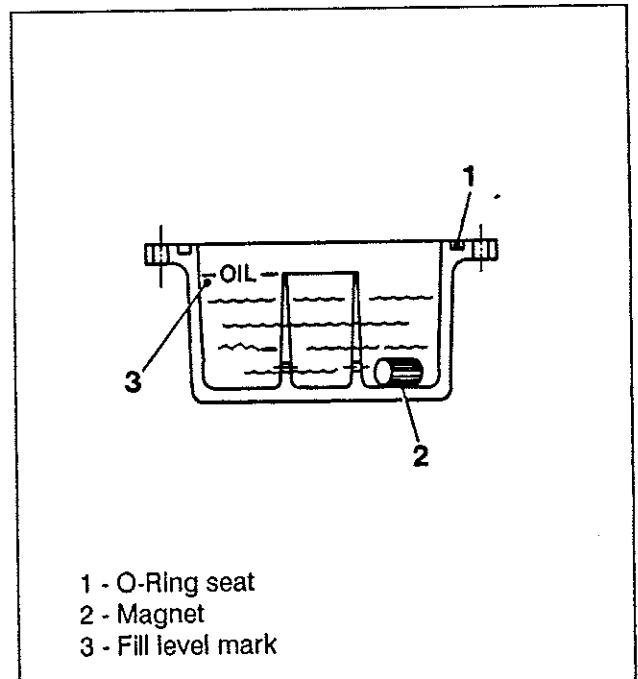

Figure 2-1 - Oil sump

2-2.2 Typical Turbo-V pump interconnections

Figure 2-2 shows the typical pump interconnections.

- 1) Turbo-V controller
- 2) Pump vent valve
- 3) High vacuum isolation valve (optional)
- 4) System vent valve (optional)
- 6) Ion gauge
- 7) Foreline flange
- 8) Forepump exhaust mist eliminator
- 9) Forepump with internal anti-suck back valve
- 10) Forepump control relay
- 11) Cooling water connections
- 13) Turbo-V80 pump

2-2.3 High-vacuum flange connection

The pump must be installed vertically with a maximum slope of 10°. The pump can either rest on its support pedestal or it can be suspended from the high-vacuum flange. If a vibration isolator or a metal bellows is used to connect the pump to the chamber, the pump must be securely anchored in place.

WARNING
<p>To avoid injury to personnel and damage to the equipment, if the pump is supported by its pedestal, make sure it is steady and unable to tip over. If necessary, attach the pump pedestal to the bench using the M6 threaded holes in the pedestal where the rubber feet are installed. These holes are located on an 88.5-mm (3.48") diameter.</p>

If the pump is operated in the presence of a magnetic field, precautions must be taken. Please contact Varian sales to assist you on this application.

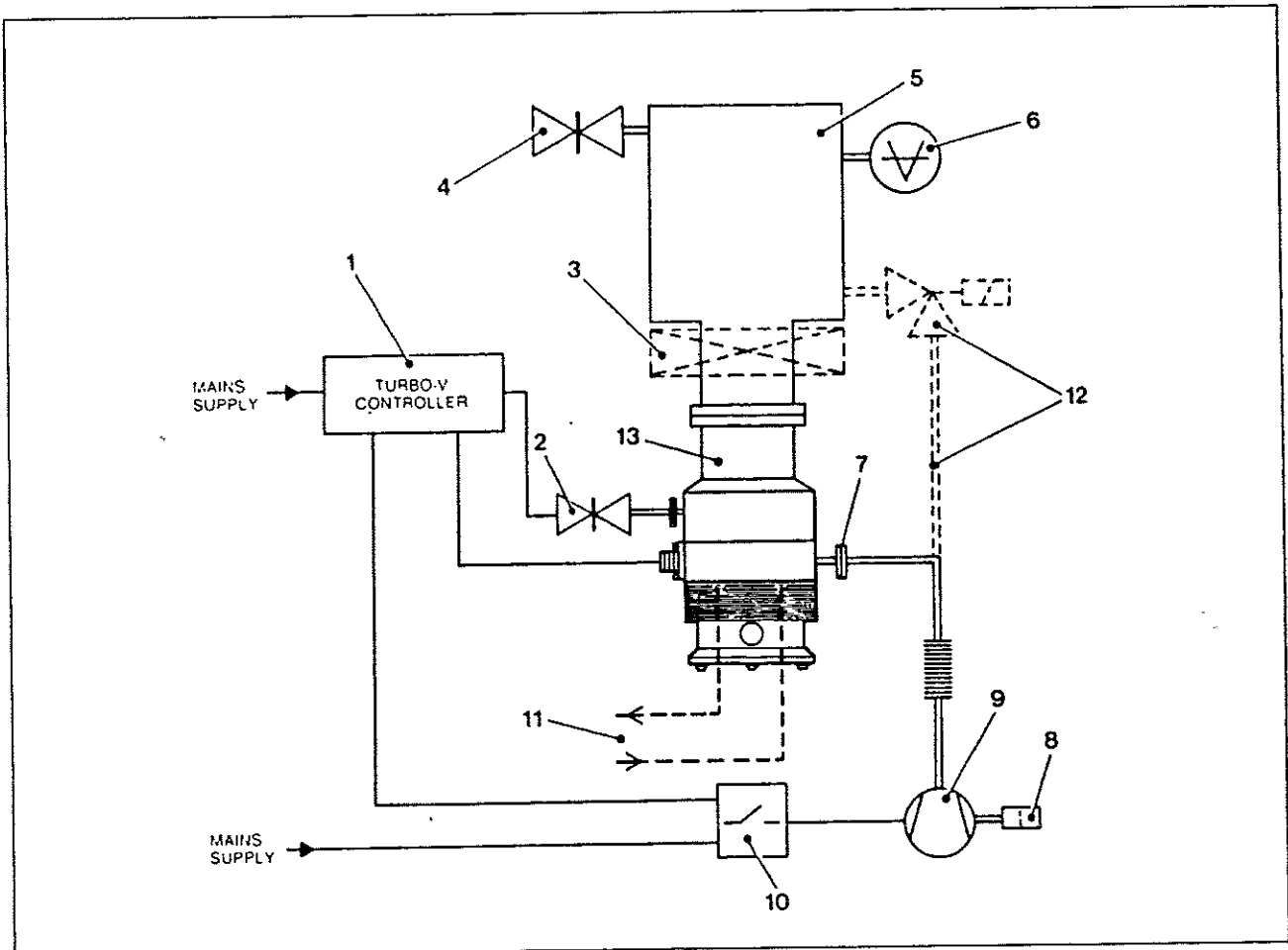

Figure 2-2 - Typical Turbo-V pump interconnections

When ready to install the pump, remove the shipping cover. Do not allow any foreign material to fall into the pump. Inspect mating hardware for cleanliness before connection to pump.

Apply high-temperature lubricant to the screw threads before installation, as proper lubrication simplifies sealing and disassembly.

Fel-Pro C-100 is recommended for this application.

NOTE

Lubrication is essential to prevent galling of the screw after bakeout.

2-2.4 Forepump connection

An NW 16 KF flange is provided at the foreline port. A flexible hose or vacuum tubing can be used to connect to the mechanical pump. If a rigid pipe is used, bellows must be installed in order to minimize the vibration transmitted from the mechanical pump to the turbomolecular pump.

The forepump must have an integral anti-suck back valve to prevent backstreaming oil into the turbomolecular pump.

2-2.5 Vent valve connection

If the pump is to be vented through the vent port, remove the screw plug and install the (optional) vent flange, then connect the vent valve.

If the Turbo-V vent device is used, the pump will be vented once the delay time has elapsed after power failure or normal shutdown.

An inlet filter can be used to prevent any particulate admission into the pump when venting to air, or the pump can be vented with dry gas.

2-2.6 Water-cooling connection

Two rifled nozzles that accept 6 mm ($1/4$ " I.D. rubber or plastic tubing are provided on the cooling jacket for the water connections.

The two nozzles are interchangeable as to supply/return connection.

Water temperature should be between $+10^{\circ}\text{C}$ and $+25^{\circ}\text{C}$ with a pressure between 2 and 4 mbar. Both open circuit with water drainage systems and closed-loop refrigerated systems may be used; however, it is advisable to make sure that the tubing is fixed by clamps, to ensure that the tubes do not detach during operation.

CAUTION

To prevent excessive electrochemical corrosion, the resistivity of the cooling water must be greater than 2×10^4 ohm-cm. Water not meeting this specification may corrode or obstruct the fittings and damage the cooling jacket.

The Turbo-V80 pump can operate for about 10 minutes without water, but a water flow switch can be installed to interlock the controller and/or to give an early alarm.

If no flow switch is installed on the water line, the thermistor mounted inside the pump will switch off the power to prevent pump damage when the internal temperature exceeds 60°C .

2-2.7 Electrical connection

WARNING

Before connecting the Turbo-V80 pump to the controller make sure that the required ground connection has been made.

Connect the controller ground terminal to the pump ground through the ground cable.

The electrical connection to the Turbo-V80 pump is through a 5-pin connector, where pins B, C and D are used for the motor and pins A and E for the thermistor (resistance is approximately 200 ohms at 20°C).

If the thermistor is disconnected, the pump cannot start.

2-3 General operation

Make all vacuum manifold and electrical connections as directed in Sect. II and refer to Turbo-V Controller Instruction Manual to operate the Turbo-V pump.

WARNING

To avoid injury to personnel, operate the Turbo-V pump only when the pump inlet is connected to the system or blanked off.

CAUTION

To prevent damage to the turbomolecular pump when the pump is running, avoid shocks or sudden change of position of the Turbo-V pump.

NOTE

*The forepump and the Turbo-V pump can be switched on at the same time if a pressure less than 1 mbar (0.75 Torr) is obtained in the chamber within the Turbo-V pump start-up time.
If the vacuum chamber is larger, it may be roughed down before starting the Turbo-V80 pump.*

2-4 Bakeout procedure

Varian recommends that the system chamber and the pump flange are heated to shorten the pumpdown time to base pressure.

CAUTION

The maximum temperature allowed at the high-vacuum flange is 120°C. Make sure that this temperature is never exceeded.

If the pump accessory heater is used, switch it on upon start-up to bake out the turbopump during pumpdown. If the pump becomes overheated for any reason, the thermistor will remove power from the pump. To achieve best ultimate vacuum, wait until the chamber cools to room temperature after bakeout.

NOTE

Do not bake out the Turbo-V pump when it is operating at a pressure above 10^{-4} mbar range.

3-1 General

A replacement pump is available on an advance exchange basis through Varian Service.

3-2 Turbo-V80 pump maintenance

WARNING

To avoid injury to personnel, wait until the Turbo-V pump stops completely before disconnecting it from the chamber.

3-2.1 Oil change

The oil must be changed every six months or whenever the oil becomes opaque or dark brown.

To change the oil:

- a) Unscrew the four screws attaching the oil sump to the pump.
- b) Lower the sump, empty the old oil.
- c) Clean the sump thoroughly with Freon (do not use alcohol) and fill with a new charge of oil. Place the magnet in the external basin of the sump.
- d) Reattach the sump immediately to avoid particulate contamination, making sure the O-ring is properly cleaned and seated. Do not overtighten screws to avoid breakage of the plastic flange.

NOTE

Do not mix oil; use only Varian T.A. oil.

3-2.2 Cleaning

If the pump becomes contaminated for any reason, it will extend system pumpdown times. It is then necessary to clean the pump in order to remove all foreign matter deposited on the rotor blades.

Cleaning must be performed in the following order (refer to fig. 3-1):

- 1) Remove the heater-if installed. Remove the oil sump and let the oil drain for about two hours.
- 2) Prepare a very clean container and fill it with a suitable solvent.

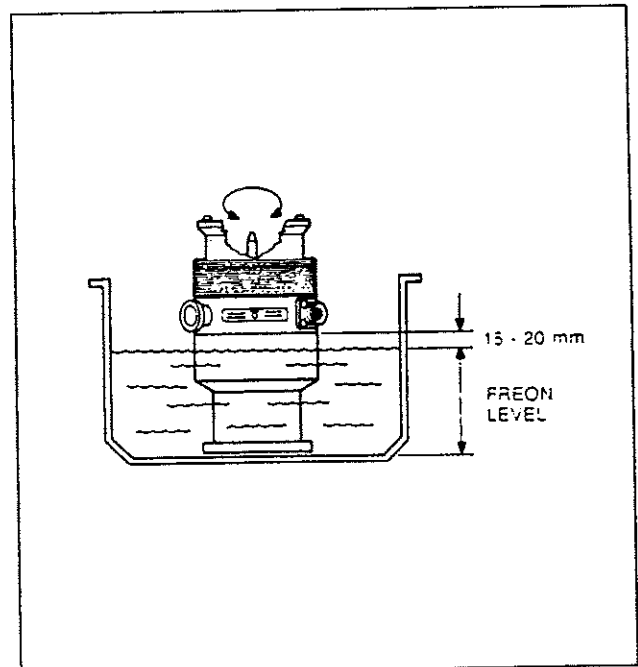

Figure 3-1 - Assembly pump cleaning

- 3) After the oil has completely drained, turn the pump upside-down and lower it into the solvent bath. Make sure that the solvent level is 15-20 mm below the end of the pump upper body envelope when inverted (refer to fig. 3-1).

CAUTION

Do not immerse the pump any further to prevent damage to the motor and the bearings.

- 4) With the pump immersed in solvent to the indicated level, slowly rotate the rotor by turning the conical shaft by hand. This turning motion wipes the rotor blades clean of any contamination.
- 5) Repeat this cleaning operation 2 or 3 times, replacing the solvent each time with new solvent.
- 6) Remove the pump from the solvent and rest it on a flat, clean surface still in the inverted position for at least 10 minutes, to allow the pump interior to dry properly. Take care not to scratch the inlet flange sealing area.
- 7) Place the pump in upright position. Clean the sump and fill it with a new charge of oil. Insert the magnet in the outer annulus and mount the sump on the pump.
- 8) The pump is ready to be installed.

3-2.3 Bearing replacement

The bearings are the only parts of the pump subject to wear and they must be replaced about every 15,000 hours or when noise exceeds the specification values.

Bearing replacement can only be carried out using special tools by Varian Service-trained technicians.

Bearing replacement must be done in a dust-free environment. Contact Varian Service for detailed information.

3-3 Accessories

Description	Part Number
Inlet screen	969-9301
Pump heater 120 Vac	969-9802
Pump heater 220 Vac	969-9801
Mating ISO 63 blank flange	969-9111
Centre ring ISO 63 (with O-ring)	969-9112
ISO clamp kit (pkg./4)	969-9113
Mating 4 ¹ / ₂ " ConFlat flange (bored)	954-5078
Screws, nut, washers (pkg/25)	953-5022
Thread lubricant Fel-Pro C100	953-0031
Vibration isolator ISO 63	969-9341
Vibration isolator 4 ¹ / ₂ " CFF	969-9331
Forepump SD 90, 220V, 50 Hz, 1 ph.	949-0867-280
Forepump SD 90, 1 ph. universal motor	0420-P1201-307
Vent flange NW 10 KF	969-9109
Turbo-V vent device 120V, 50-60 Hz	969-9831
Emergency vent valve	969-9832
Varian T.A. oil 100 cc	969-9901
Varian T.A. oil 1000 cc	969-9902

For a complete overview of Varian's extensive vacuum product line, please refer to the Varian vacuum catalog.

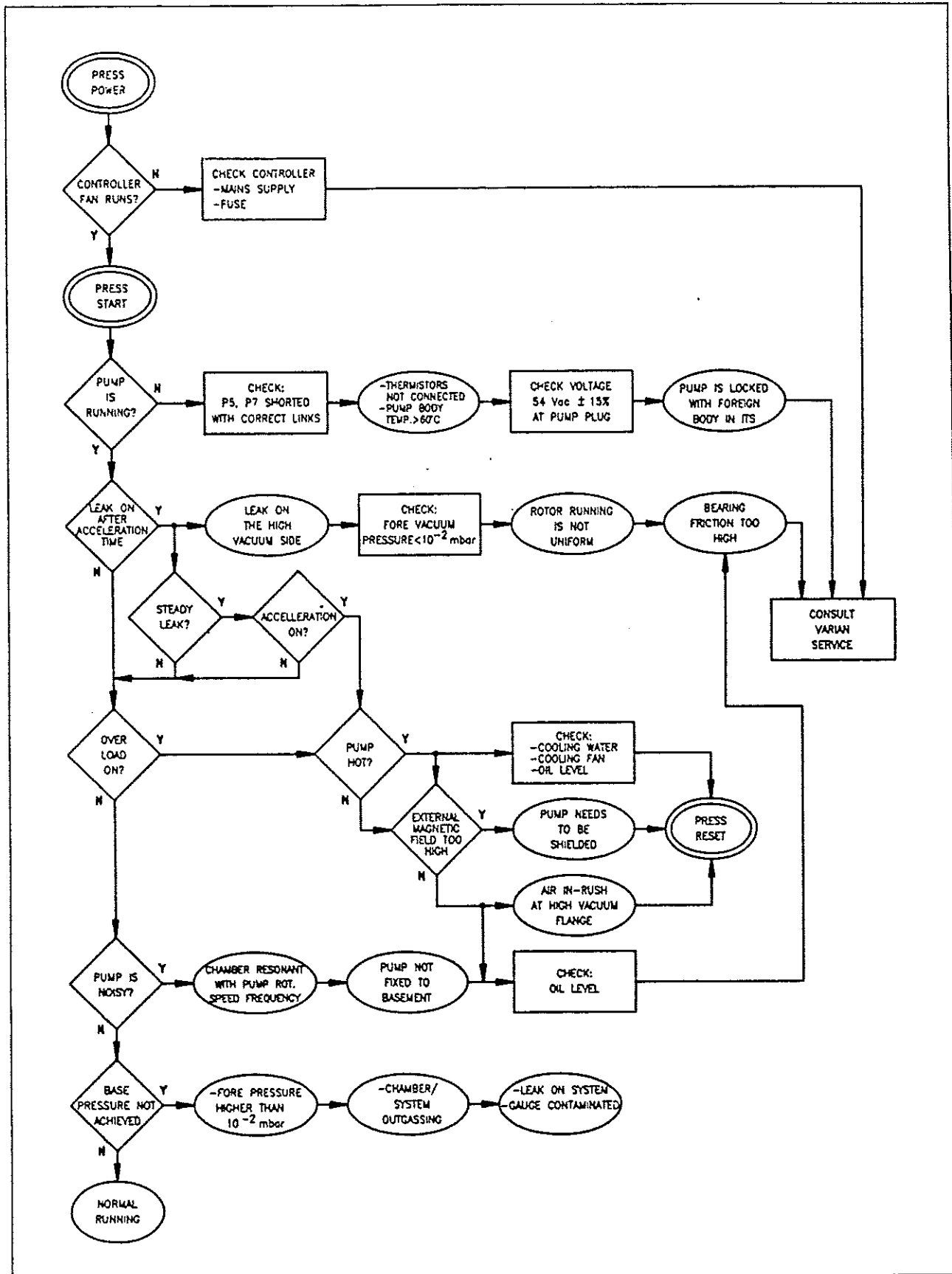

Figure 3-2 - Turbo-V pump troubleshooting chart
using Turbo-V controller 969-9412 or 969-9512

Varian S.p.A. - Vacuum Products Torino
Via Varian 54, 10040 Leinì (Torino) - Italy
Tel. (39) 11 9979111 - Telefax: (39) 11 9979350 - Telex: 210297

Varian Vacuum Products Lexington
121 Hartwell Avenue - Lexington, MA 02173 USA
Tel.: (617) 861-7200 - Telefax: (617) 860-5437 - Telex: 710-321-0019

FRANCE

Varian S.A.
Quartier de Courtaboeuf
B.P. 12
F-91941 Les Ulis-Cedex
Tel.: (33) 16 9863838
Telefax: (33) 16 9282308

INDIA

Varian Vacuum Products
No. 7 Community Center, 1st Floor
Basant Lok, Vasant Vihar
New Delhi 110057, India
Tel.: (91) 11 6883391
Telefax: (91) 11 6873664
Telex: 3182038

USA, SOUTH & CENTRAL AMERICA

Varian Vacuum Products
121 Hartwell Avenue
Lexington, MA 02173
Tel.: (617) 861 7200
Telefax: (617) 860 5437
Telex: 710 321 0019
Toll free nr.: 1-800-882-7426

GERMANY, AUSTRIA

Varian GmbH
Vacuum Products
Kuehnstrasse 71 D
22045 Hamburg
Tel.: (49) 40 6696033/34
Telefax: (49) 40 6682282
Telex: 211798

KOREA

Varian Korea Ltd.
433-1 Mogok-Dong, Songtan
Kyungi-Do, Korea 459-040
Tel.: (82) 333 6655171
Telefax: (82) 333 6650118
Telex: VARKOR K 28663

CANADA

Varian Canada Inc.
6705 Millcreek Drive, Unit 5
Mississauga, Ontario L5N 5R9
Tel.: (416) 819 8188
Telefax: (416) 819 8348
Toll free nr.: 1-800-663-2727

U.K.

Varian Ltd.
28 Manor Road
GB-Walton-on-Thames
Surrey KT1 2QF
Tel.: (44) 932 243741
Telefax: (44) 932 228769
Telex: 928070

JAPAN & OTHER ASIAN COUNTRIES

Varian, Vacuum Products Japan
Sumitomo Shibaura Bldg.
4-16-36 Shibaura
Minato-ku, Tokyo, 108 Japan
Tel.: (81) 3 5232 1211
Telefax: (81) 3 5232 1710

AUSTRALIA

Varian Australia Pty Ltd
6/81 Frenchs Forest Road
Frenchs Forest NSW 2086
Australia
Tel.: (61) 2 451 9133
Telefax: (61) 2 452 2600

ITALY

Varian S.p.A. - VP Sales Office
Via Varian 54
I-10040 Leinì (Torino)
Tel. (39) 11 9979111
Telefax: (39) 11 9979330
Telex: 210297

Service Center & Warehouse:
Varian Vacuum Products
5-8-11 Kita-Shinagawa,
Shinagawa-ku
Tokyo 141, Japan
Tel.: (81) 3 3449 4539
Telefax: (81) 3 3449 4597

OTHER COUNTRIES

Varian S.p.A. - VP. Sales Office
Via Varian 54
I-10040 Leinì (Torino) - Italy
Tel.: (39) 11 9979111
Telefax: (39) 11 9979 330
Telex: 210297

