

Translation of the Original Operating Instructions

Diaphragm Pump



MVP 015-4

Index

	Page
1. Safety Precautions.....	3
1.1. For Your Orientation	3
1.2. Pictogram Definitions	3
2. Understanding The Pump.....	4
2.1 Main Features	4
2.2. Differences Between The Pump Types.....	4
3. Installation.....	5
3.1. Setting Up The Pump And Location	5
3.2. Connecting The Vacuum Side.....	5
3.3. Connecting The Exhaust Side	5
3.4. Connecting To Mains Power	5
4. Operations.....	6
4.1. Important Information.....	6
4.2. Switching ON/OFF The Pump	6
4.2. Intermittent Operations	6
5. What To Do In Case Of Breakdown?	7
6. Maintenance.....	8
6.1. Precautionary Measures During Maintenance Work	8
6.2. Cleaning And Replacing Valves And Membranes	8
6.3. Dismantling The Pump	8
6.4. Assembling The Pump.....	8
7. Service	10
8. Technical Data.....	11
8.1. Substances Which Come Into Contact With The Medium	11
8.2. Dimensions.....	12
9. Spare Parts	12
10. Accessories.....	12
Conformity Declaration	last page

Please note:

Current operating instructions are also available via
www.pfeiffer-vacuum.net.

1. Safety Precautions

- ☞ Read and follow all the instructions in this manual.
- ☞ Inform yourself regarding:
 - ☞ Hazards which can be caused by the pump;
 - ☞ Hazards which can arise in your system;
 - ☞ Hazards which can be caused by the medium being pumped.
- ☞ Avoid exposing any part of the body to vacuum.
- ☞ Observe all safety and accident prevention regulations.
- ☞ Check regularly that all safety requirements are being complied with.
- ☞ Do not carry out any unauthorised conversions or modifications on the pump.
- ☞ When returning the pump to us please note the shipping instructions in Section 7.
- ☞ Do observe strictly the proper use.

Proper use

- The Diaphragm Pump may only be used for the purpose of generating vacuum.
- Do not pump corrosive or explosive gases.
- Do not pump liquids.
- Do not operate the pump in locations where there is an explosion hazard.
- Accessories other than those named in this manual may not be used without the agreement of Pfeiffer Vacuum.
- Do not use the connecting line between the heads of the pump as a handle.
- Equipment must be connected only to a suitable fused and protected electrical supply and a suitable earth point.
- Ensure that installation is in compliance with limitations from the degree of protection, see section "Technical Data".

Improper Use

The following are regarded as improper:

- The pumping of corrosive gases (except with corrosive gas processes version).
- The pumping of explosive gases.
- Operating the pump in locations where there is an explosion hazard (a special version for this application is available on request).
- The pumping of gases which are contaminated with particles, dust and condensate.
- The Pump may not be used for the purpose of generating pressure.
- The pumping of liquids.
- Connection to pumps and units which is not permitted according to their operating instructions.
- Connection to units which contain touchable and voltage carrying parts.

Improper use will cause any rights regarding liability and guarantees to be forfeited.

1.1. For Your Orientation

Instructions in the text

➔ Operating instructions: Here you have to do something!

Symbols used

The following symbols are used throughout in the illustrations:

- Ⓥ Vacuum flange
- Ⓛ Exhaust flange
- ⚡ Power supply connection

Position numbers

Identical components and accessories parts have the same position numbers in all illustrations.

1.2. Pictogram Definitions



Danger of personal injury.



Danger of damage to the pump or system.



Danger of burns from touching hot parts.



Danger of an electric shock.



Attention to particularly important information on the product, handling the product, or to a particular part of the documentation.

Modifications reserved

2. Understanding The Pump

2.1. Main Features

Diaphragm Vacuum Pump MVP 015-4

- 1 Membrane head 1
- 2 Membrane head 2
- 3 Membrane head 3
- 4 Membrane head 4
- 5 Vacuum flange (direct screw joint)
- 6 Voltage supply
- 7 Exhaust (silencer)
- 9 Capacitor

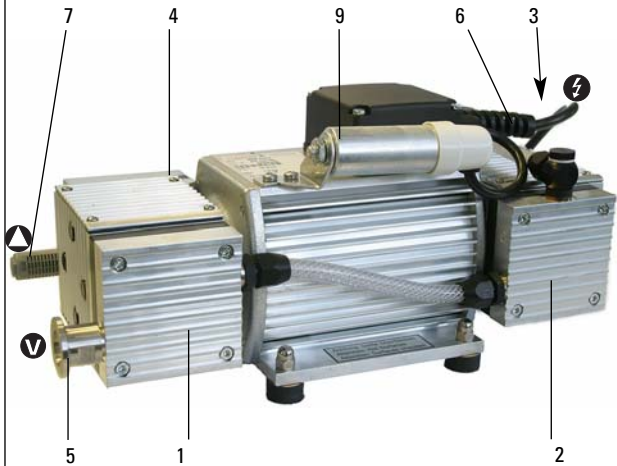

The diaphragm pump can be applied in all areas where an oil-free, dry vacuum is required.

Particularly the pump is suitable as backing pump for many Pfeiffer Vacuum turbopumps in applications involving light gas loads only.

Further applications:

- Pumping stations
- Plants
 - Research
 - Laboratories
 - Analytical
 - Chemistry
 - Leak detection

2.2. Differences Between The Pump Types

Features	Unit	MVP 015-4
Volume flow rate at 1000 mbar and 50 Hz	l/min	15
Pump stages		four-stage
Connection of the membrane heads		1-->2 in series 3-->4 in series
Final pressure at 50 Hz	mbar	< 0.5
Mains connection	Connecting cable hard-wired in terminal box, without mains switch	

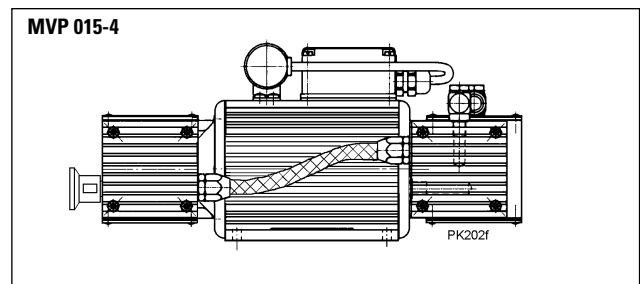

3. Installation

3.1. Setting Up The Pump And Location

- ➔ Place pump on a smooth, even surface.
- ➔ Anchor the pump if it is to be erected in a stationary position.
- ➔ Avoid mechanical stresses due to rigid connections. Insert elastic hoses or resilient elements as couplings between the pump and rigid pipes.
- ➔ Anchoring is not necessary if the pump is not erected in a stationary position.
- ➔ Maximum ambient temperature +12 ... +40 °C.
- ➔ Where rack installation is involved, ensure adequate ventilation. If pump is installed above 1000 m above mean sea level check compatibility with applicable safety requirements, e. g. DIN VDE 0530 (motor may overheat due to insufficient cooling).

3.2. Connecting The Vacuum Side

- Remove locking cap on intake connection.
- Make connection between the vacuum system and pump as short as possible.
- Connect pump with intake connection to the apparatus.
- If liquid - which would generate vapours - is present in the system to be evacuated, a condensate trap must be fitted upstream of the pump.

3.3. Connecting The Exhaust Side



Pressure can rise to dangerous levels in exhaust lines. Therefore, lay exhaust side lines without shut-off units. Do not connect the exhaust side with a closed system on account of the danger of bursting.

In certain applications, exhaust gases and vapours can be very hot and represent a health and/or environment hazard. Lay lines from the pump sloping downwards so that condensate cannot run back into the pump, otherwise fit a separator.

3.4. Connecting To Mains Power

The pump is driven by AC motors with the following possible variants:

230 V + 5% / -10%, 50 Hz

120 V + 5% / -10%, 60 Hz



Power connections must comply with local regulations. Voltage and frequency information given on the rating plate must correspond to the mains voltage and frequency values. The pump may only be connected to mains current with earthed conductor.



Pump versions where the thermostatic winding protection protrudes must be appropriately wired to ensure the motor is protected.

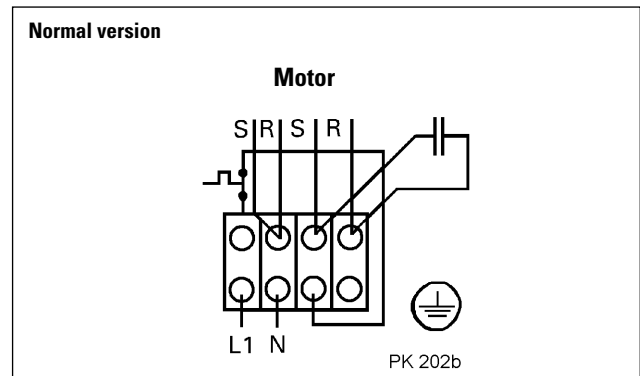

4. Operations

4.1. Important Information



Before starting, ensure that impermissibly high pressures cannot build up on the pressure side. Interchanging the connections causes dangerous excess pressure levels.

The pumps should only start, when the pressure difference is max. 1 bar between admission and exhaust, because the motor will be blocked and damage.



When the pump is running, surfaces and motor casing become hot.

4.2 Switching ON/OFF The Pump

The pump can be switched on and off at all times.



Prevent internal condensation, transfer of liquids or dust. The diaphragm and valves will be damaged, if liquids are pumped in significant amount over lengthy periods!

If the pump is subjected to condensates it should be allowed to run for a few minutes under atmospheric pressure before switching off.

4.3 Intermittent Operations

To prolong the life of diaphragm pumps, intermittent operations can be selected with lesser gas throughputs of < 0.18 mbar l/s. This means that, dependent on the turbo pump power take-up, the backing pump will be switched on and off. Turbo pump power take-up is dependent on the fore-vacuum pressure and gas throughput.

- By comparing the power take-up with an upper and a lower limit value, the relative switch-on duration with lesser gas throughputs can be reduced to approx. 1 to 60%
- To avoid too frequent switching on, the buffer volume in the fore-vacuum line should amount to < 0.5 liter from approx. 0.018 mbar l/s.

Possible intermittent operations variations are shown in the following diagram:

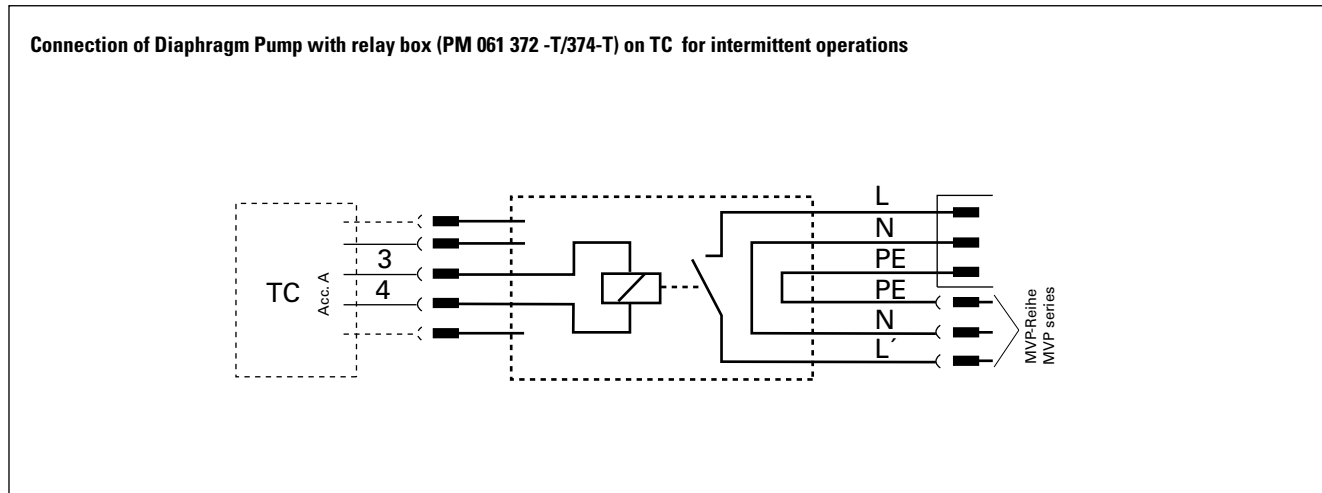

5. What To Do In The Case Of Breakdowns ? ---

Problem	Possible cause	Remedy
Pump does not attain final pressure	<ul style="list-style-type: none"> • Condensate in the pump • Valves/diaphragms defective/dirty • Leak in system 	<ul style="list-style-type: none"> • Run pump for a longer period under atmospheric pressure • Clean or replace valves and diaphragms, see section 6. • Repair leak
Unusual operating noises	Valves/diaphragms defective Dirt in the working chamber Silencer loose or missing Valves defective Motor fan defective Con-rod or motor bearing defective	See maintenance in section 6. Clean working chamber. Check silencer; clean or replace. Change valves. Change motor fan. Inform Pfeiffer-Service.
Pump does not start	No mains voltage Phase failure Motor overheating Ambient temperature < 12 °C Dirty valves/diaphragms Over-pressure in the exhaust line	Check power supply. Check fuse. Allow the motor to cool down and depress mains switch off/on. Warm pump. See maintenance in section 6. Open exhaust line (open exhaust valve).
Pump switches off	<ul style="list-style-type: none"> • Sticking diaphragms • Wrong mains voltage 	<ul style="list-style-type: none"> • Clean pump (see section 6.) • Correct as per rating plate

6. Maintenance

6.1. Precautionary Measures During Maintenance Work



Whenever working on the pump ensure the motor cannot get switched on. If necessary, remove pump from the system for inspection. Before dismantling allow the pump to cool down.

- ➔ Only dismantle the pump as far is necessary to effect repairs.
- ➔ Use only benzine or the like for cleaning. Do not use solvents.

6.2. Cleaning And Replacing Valves And Membranes

Under normal operating conditions, the pump is maintenance free. The valves and the diaphragms are wear parts. If the rated ultimate vacuum is no longer achieved, the pump interior, the diaphragms and the valves must be cleaned and the diaphragms and valves must be checked for cracks or other damage.

Depending on individual cases it may be efficient to check and clean the pump heads on a regular basis. In case of normal wear the **lifetime of the diaphragms and valves is > 10000 operating hours.**



There can be different numbers of washers 17 in each membrane head. Ensure the correct assignment for mounting when dismantling the membrane heads. Don't confuse the washers 17.

6.3. Dismantling The Membrane Head

- ➔ Allow the pump to cool down before dismantling.
- ➔ Using an SW 14 key, unscrew direct screw joint (20) of interhead connection (10) on diaphragm head 1 (see marks on the housing).
- ➔ As far as possible place pump on its side so that the head to be dismantled points up.
- ➔ Using an SW 3 key, unscrew the four Allan head screws (11) and remove head cover (12), taking care with the two valve plates (13) and sealing rings (14).
- ➔ Remove intermediate plate (15).
- ➔ Use a small screwdriver to carefully ease out diaphragm (16) and manually unscrew from the connecting rod (right-hand thread). Look out for possible washers (17).
- ➔ Clean all parts with alcohol and examine diaphragms, valves and seals for possible damage and renew as necessary. If a new diaphragm is to be fitted, the washers (17) of the old diaphragm must be used again otherwise the pump will not attain the required pressure.

6.4. Assembling The Membrane Head

- ➔ Assemble all parts in reverse order. The connecting rod should be positioned in the upper dead point when fitting the diaphragm. Ensure correct positioning of all parts.
- ➔ Check correct sealing ring seating.
- ➔ Re-make hose connection and re-tighten direct screw joint (20).
- ➔ Test pump for function.

Dismantling the membrane head

- | | |
|---------------------|-----------------------|
| 11 Allan head screw | 15 Intermediate plate |
| 12 Head cover | 16 Diaphragm |
| 13 Valve plate | 17 Washer |
| 14 Sealing ring | |

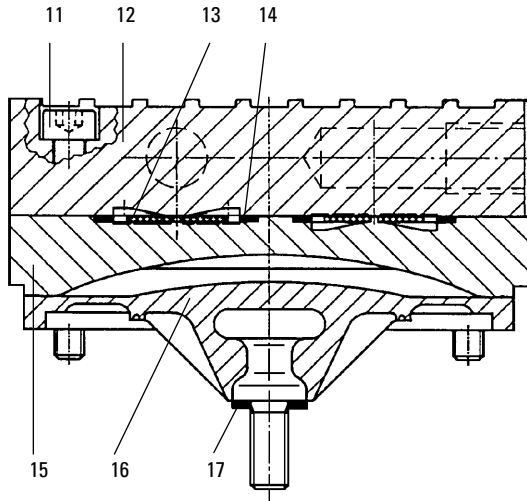

- | |
|--------------------------------------|
| 1 Membrane head 1 |
| 2 Membrane head 2 |
| 4 Membrane head 4 |
| 5 Vacuum flange (direct screw joint) |
| 7 Exhaust (silencer) |
| 9 Capacitor |
| 10 Interhead connection 1-2 |
| 10a Interhead connection 2-3 |
| 11 Allan head screw |
| 20 direct screw joint |

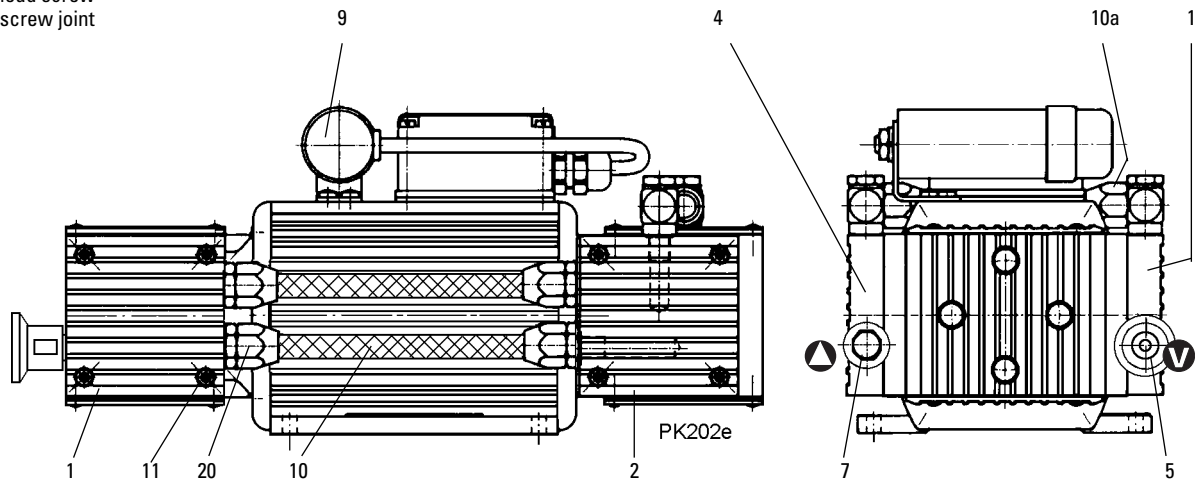

7. Service

Do Make Use Of Our Service Facilities

In the event that repairs are necessary to your pumping station, a number of options are available to you to ensure any system down time is kept to a minimum:

- Have the pump repaired on the spot by our Pfeiffer Vacuum Service Engineers;
- Return the individual components to the manufacturer for repairs;
- Replace individual components with a new value exchange units.

Local Pfeiffer Vacuum representatives can provide full details.

Before Returning:

- ➔ Dismantle all accessories.
- ➔ Attach a clearly visible notice: "Free of contamination" (to the unit being returned, the delivery note and accompanying paperwork).

Harmful substances" are substances and preparations as defined in current legislation. Pfeiffer Vacuum will carry out the decontamination and invoice this work to you if you have not attached this note. This also applies where the operator does not have the facilities to carry out the decontamination work. Units which are contaminated microbiologically, explosively or radioactively cannot be accepted as a matter of principle.

Fill out the service request and the declaration on contamination

- ➔ Download the forms "Service Request" and "Declaration on Contamination".¹⁾
- ➔ Fill out the "Service Request" form and send it by fax or e-mail to your Pfeiffer Vacuum service address.
- ➔ Include the confirmation on the service request from Pfeiffer Vacuum with your shipment.
- ➔ Fill out the contamination declaration and enclose it in the shipment (required!).

Please get in touch with your local Pfeiffer Vacuum representatives if there are any questions regarding contamination.



Decontaminate units before returning or possible disposal. Do not return any units which are microbiologically, explosively or radioactively contaminated.

Returning contaminated units

If contaminated have to be returned for maintenance/repair, the following instructions concerning shipping must be followed:

- ➔ Neutralise the pump by flushing with nitrogen or dry air.
- ➔ Seal all openings to the air.
- ➔ Seal pump or unit in suitable protective foil.
- ➔ Return equipment only in suitable, rugged shipping containers and by complying with the currently valid shipping regulations.



Repair orders are carried out according to our general conditions of sale and supply.

- ➔ If repairs are necessary, please send the unit together with a short damage description to your nearest Pfeiffer Vacuum Service Center.

¹⁾ Forms under www.pfeiffer-vacuum.net

8. Technical Data

Size	Unit	MVP 015-4
Connections		
Intake side		G 1/8" +silencer
Pressure side		G 1/8" +silencer
Nominal volume flow rate at 1000 mbar		
50 Hz	l/min	15
60 Hz	l/min	18
Volume flow rate at 10 mbar		
50 Hz	l/min	4
60 Hz	l/min	4,5
Final pressure	mbar	≤ 0.5
Permissible exhaust pressure	mbar	1050
Leakrate to vacuum chamber when pump is switched off	mbar l/sec	≤ 5·10 ⁻³
Integral Leakrate	mbar l/sec	≤ 1·10 ⁻³
Max. operating altitude (a. s. l.)	m	approx. 2000
Max. permissible gas- and environment temperature	°C	+12 ... +40
Overload protection (coiled temperature switch)	°C	118
Noise level	dB(A)	ca. 52
Motor (insulation material class B)		IP 54
Power at 230 V 50 Hz	W	80
Power at 115 V 60 Hz	W	80
Weight, approx.	kg	7.5

8.1. Substances Which Come Into Contact With The Medium

Pump components	Substances in contact with the media (MVP 015-4)
Diaphragm	EPDM
Valves	EPDM
Pump head	Aluminium
Tupee	PVC
Swivelling screw-fitting	Aluminium
Silencer	Polyamide

8.2. Dimensions

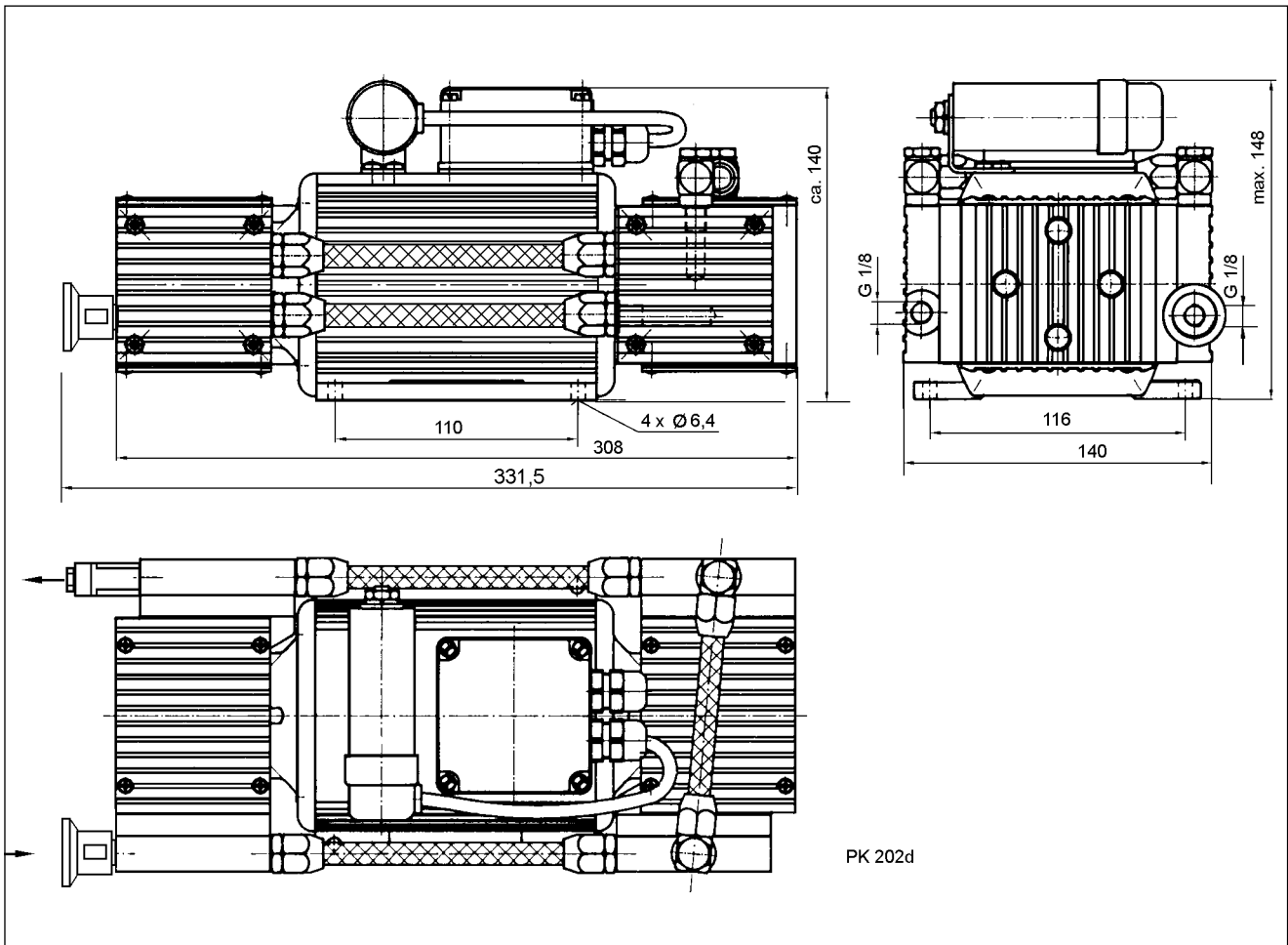

9. Spare Parts

Pos.	Description	Pieces	Size	Number	Comments/relevant	Ord. Quantity
	MVP 015-4 Spare parts pack contains all necessary wear parts:	2		PU E22 009 -T	not included in the delivery consignment	
7	Silencer	1		PO 920 567 E	not included in the delivery consignment	

When ordering accessories and spare parts please be sure to state the full part number. When ordering spare parts please state additionally the unit type and unit number (see rating plate). Please use this list as an order form (by taking a copy).

10. Accessories

Description	Pieces	Size	Number	Comments/relevant
Relaybox, 1 phas. 5A for connection to TC 110	1	94 x 65 x 57 (mm)	PM 061 372 -T	
Relaybox, 1 phas. 5A for connection to TC 400	1	94 x 65 x 57 (mm)	PM 061 374 -T	



Konformitätserklärung Declaration of Conformity

nach EG-Richtlinie/according to the EC directive:

- Maschinen/Machinery 2006/42/EG (Anhang/Annex II, Nr. 1 A)

Hiermit erklären wir, dass das unten aufgeführte Produkt allen einschlägigen Bestimmungen der EG-Maschinenrichtlinie 2006/42/EG entspricht. Zusätzlich entspricht das unten aufgeführte Produkt allen einschlägigen Bestimmungen der EG-Richtlinie "Elektromagnetische Verträglichkeit" 2004/108/EG . Bevollmächtigter für die Zusammenstellung der technischen Unterlagen ist Herr Sebastian Oberbeck, Pfeiffer Vacuum GmbH, Berliner Straße 43, 35614 Aßlar.

We hereby declare that the product cited below satisfies all relevant provisions of EC Machinery Directive 2006/42/EC. In addition, the product cited below satisfies all relevant provisions of EC Directive "Electromagnetic Compatibility" 2004/108/EC .

The agent responsible for compiling the technical documentation is Mr. Sebastian Oberbeck, Pfeiffer Vacuum GmbH, Berliner Straße 43, 35614 Aßlar.

Produkt/Product:

MVP 015-4

Angewendete Richtlinien, harmonisierte Normen und angewendete, nationale Normen und Spezifikationen/
Guidelines, harmonised standards and national standards and specifications which have been applied:

DIN EN ISO 12100-1 : 2004
DIN EN ISO 12100-2 : 2004
DIN EN 1012-2 : 1996

DIN EN 60335-1 : 2007
DIN EN 55014-1 : 2007
DIN EN 55014-2 : 2009

DIN EN 61000-3-2 : 2006
DIN EN 61000-3-3 : 2009

Unterschriften/Signatures:

Pfeiffer Vacuum GmbH
Berliner Str. 43
35614 Asslar
Germany

(M. Bender)
Geschäftsführer
Managing Director

(Dr. M. Wiemer)
Geschäftsführer
Managing Director

CE/2010

Vacuum is nothing, but everything to us!



Turbopumps



Rotary vane pumps



Roots pumps



Dry compressing pumps



Leak detectors



Valves



Components and feedthroughs



Vacuum measurement



Gas analysis



System engineering



Service

PFEIFFER  **VACUUM**

Pfeiffer Vacuum Technology AG · Headquarters/Germany

Tel. +49-(0) 64 41-8 02-0 · Fax +49-(0) 64 41-8 02-2 02 · info@pfeiffer-vacuum.de · www.pfeiffer-vacuum.net