

Vacuum Pumps

Instrumentation

Fittings and Valves



LEYBOLD VACUUM

GA 05.123/3.02

idealvac.com
Ideal
vacuum products
(505)872-0037
idealvac.com

TURBOVAC
340 M
340 MC
340 MCT
341 MCT

Turbomolecular Pumps
with Magnetic Bearing

Cat. No.

855 80/81/82/83

894 32, 855 97

894 33

894 34

Operating Instructions

Contents

	Page
1 Description	3
1.1 Design of the TURBOVAC	4
1.2 Temperature control	4
1.3 Purge gas	6
1.4 Standard specification	6
1.5 Technical data	7
1.6 Ordering data	9
2 Installation	10
2.1 Operating environment	10
2.2 Connecting the TURBOVAC to the vacuum chamber	10
2.3 Connecting the backing pump	14
2.4 Connecting the cooling	15
2.5 Connecting the purge gas valve and power failure airing valve	18
2.6 Attaching the flange heater	20
2.7 Connecting the TURBOTRONIK	20
3 Operation and Control	21
3.1 Switching on	21
3.2 Operation	21
3.3 Bake-out	22
3.4 Switching off	22
3.5 Venting	23
3.6 Power failure - Cable break	24
4 Maintenance	25
4.1 Replacing the diaphragm filter of the purge gas and venting valve	25
4.2 Removing the pump from the system	26
4.3 Service at Leybold's	26

Warning

Indicates procedures that must be strictly observed to prevent hazards to persons.

Caution

Indicates procedures that must be strictly observed to prevent damage to, or destruction of the TURBOVAC.

Figures

The references to diagrams, e. g. (1/2) consist of the Fig. No. and the Item No. in that order.

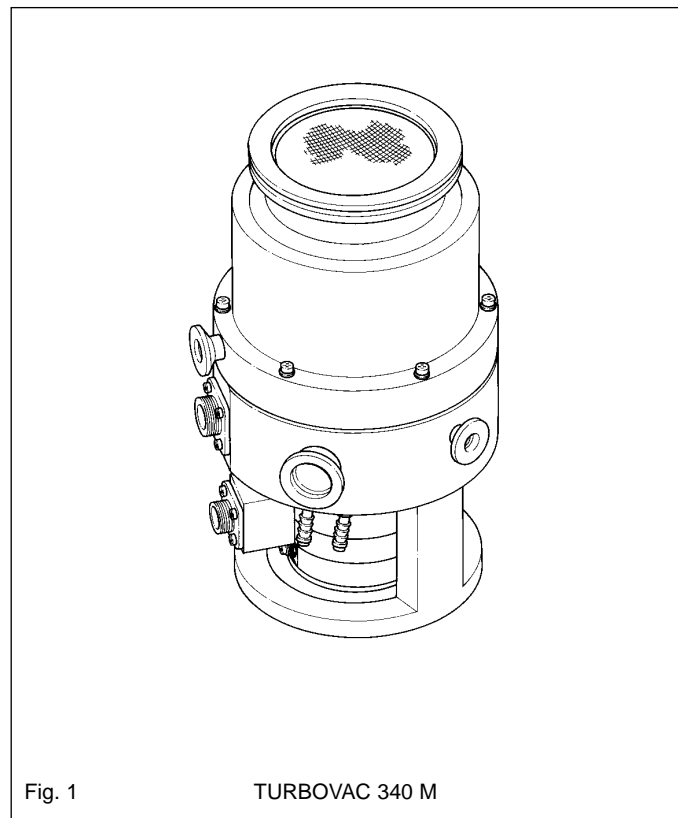

Leybold-Service

If a pump is returned to Leybold, indicate whether the pump is free of substances damaging to health or whether it is contaminated. If it is contaminated also indicate the nature of hazard. Leybold must return any pump without a declaration of contamination to the sender's address.

We reserve the right to alter the design or any data given in these Operating Instructions. The illustrations are not binding.

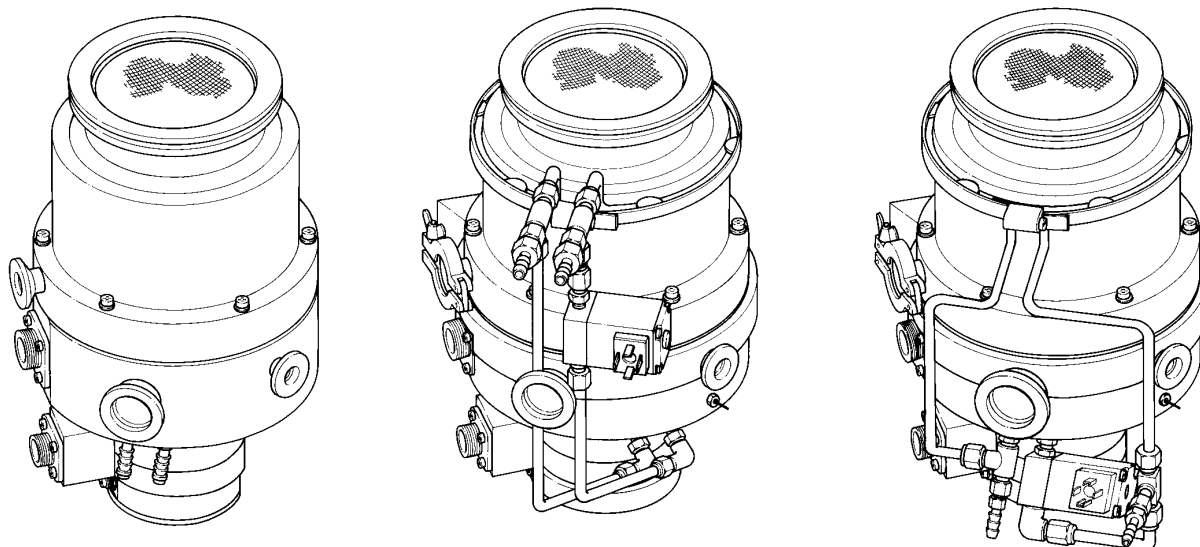

Fig. 2 TURBOVAC 340 MC

TURBOVAC 340 MCT

TURBOVAC 341 MCT

1 Description

The TURBOVAC 340 M, 340 MC, 340 MCT, and 341 MCT are turbomolecular pumps utilizing magnetic bearings. They are designed to evacuate vacuum chambers down to pressure values in the high-vacuum range.

The rotor and stator plates of the TURBOVAC 340 MC, 340 MCT, and 341 MCT are protected with a special ceramic layer.

The TURBOVAC 340 MCT and 341 MCT are equipped with a temperature control device.

The TURBOTRONIK frequency converter and a backing pump will be required for the operation of the TURBOVAC.

The TURBOVAC 340 M, 340 MC, 340 MCT, and 341 MCT, referred to below simply as "TURBOVAC", are the product of joint development activities by Leybold and the Research Center at Jülich.

Compatibility with pumped media

Turbomolecular pumps are **not** suitable for pumping either liquids or gases which contain dust particles.

Turbomolecular pumps without the protective gas feature are suitable only for moving air or inert gases. They are **not** suitable for pumping corrosive or reactive gases.

The TURBOVAC are fitted with purge gas device. The gas protects only the bearing section and the TURBOVAC motor.

Some media (e.g. aluminium chloride) can sublime in the pump and form deposits. Thick coatings can interfere with the clearances required for operation and ultimately cause the pump to seize. Deposits can be prevented in some processes by heating the pump. Please direct any queries to the manufacturer.

Corrosive gases (such as chlorine) can damage the rotors.

During operation the pressure inside the TURBOVAC is so low that there is no danger of ignition (at pressures below about 100 mbar). A hazardous condition will be created if flammable mixtures enter the hot pump at pressures above 100 mbar. During operation the pump can reach temperatures as high as 120°C. Sparks could occur in case of damage to the pump and these could ignite explosive mixtures.

We would be glad to consult with you as regards the media which can safely be handled with this unit, with or without purge gas.

1.1 Design of the TURBOVAC

The TURBOVAC is similar in design to the turbomolecular pumps equipped with ball bearings; it comprises basically the pump housing, the multi-stage rotor with the stator package, the drive, and a magnetic bearing. The rotor is made from an aluminum alloy. The pump is designed for operation with purge gas.

A suspension system without contact between moving parts was achieved by providing a permanently magnetic, passive bearing located near the center of gravity, this working in conjunction with a permanently magnetized stabilizer with coils effective in the axial direction. The coils are partially actively regulated by a non-contacting axial sensor with a downline electronic controller.

This bearing concept allows for low-vibration operations and insures operation of the TURBOVAC in any mounting position.

Two touch-down bearings are provided to stabilize the rotor mechanically if impacts occur during operation. These bearings use no lubricant. They also provide axial support of the pump rotor when the frequency converter is switched off.

A DC motor without commutator is used to power the rotor.

Drive voltage for the motor and the operating voltage for the active magnetic bearing are supplied by the TURBOTRONIK frequency converter. It also handles automatic monitoring of these systems.

1.2 Temperature control - TURBOVAC MCT

The TURBOVAC MCT are equipped with a temperature control to keep the temperature at the TURBOVAC constant within a narrow control range. This unit comprises essentially

- a temperature control unit (TCU),
- a temperature sensor Pt 100
- a heating collar,
- a cooling coil for the pump housing and
- a magnet valve for the cooling water.

The heating collar, the magnet valve, and the cooling coil are attached to the TURBOVAC MCT, the Pt 100 and the temperature control unit are accessories.

The temperature sensor measures continuously the temperature at the basic flange. The TURBOTRONIK switches the heating collar on or opens the magnet valve to allow cooling water to flow.

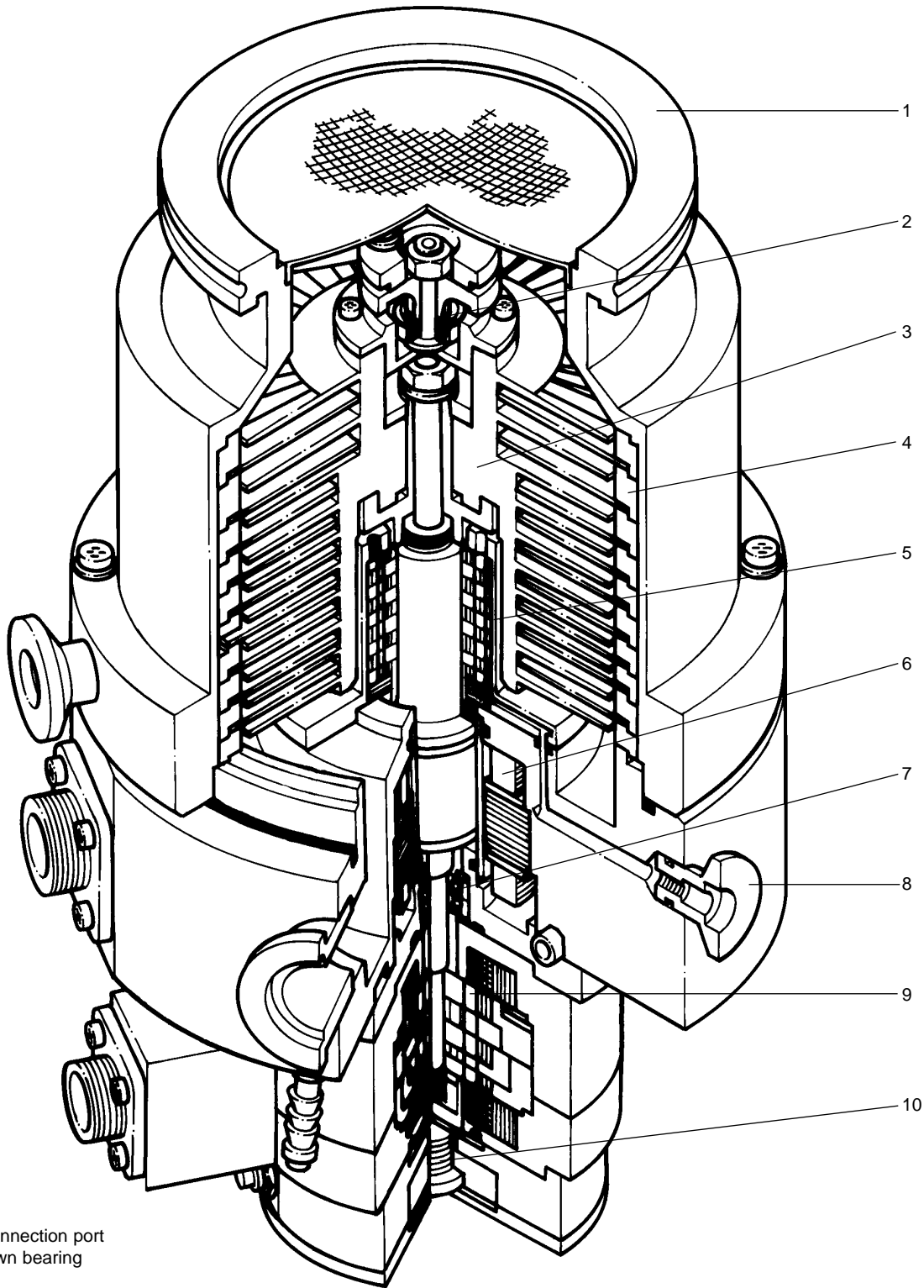

Key to Fig. 3

- 1 High-vacuum connection port
- 2 Upper touch-down bearing
- 3 Rotor
- 4 Stator elements
- 5 Permanent-magnet bearing at center of gravity
- 6 DC motor
- 7 Bottom touch-down bearings
- 8 Purge gas connection
- 9 Stabilizer
- 10 Axial sensor

Fig. 3 TURBOVAC 340 M turbomolecular pump

Key to Fig. 4

- 1 Purge gas connecting flange
- 2 Throttle nozzle
- 3 Sintered metal filter
- 4 O-rings
- 5 Diaphragm filter
- 6 Hose nozzle
- 7 Venting bypass
- 8 Solenoid valve
- 9 Plug
- 10 Pin

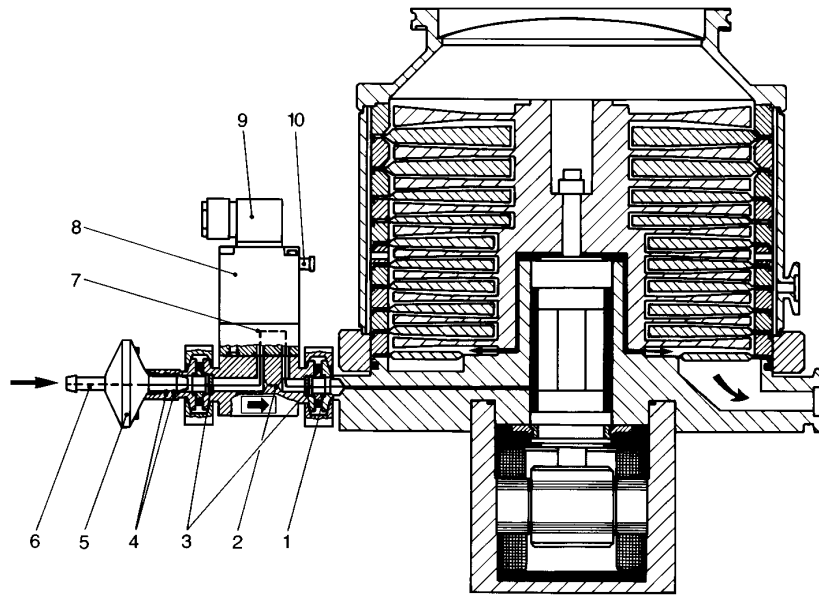

Fig. 4 Purge gas and venting valve fitted to a TURBOVAC (schematic)

1.3 Purge gas

We recommend a purge gas and venting valve for purge gas operation. It is a throttle for supplying a dosed quantity of purge gas to turbomolecular pumps, and a venting valve for turbomolecular pumps.

It is **not suitable for shutting off** the purge gas connection of a TURBOVAC.

Nitrogen, argon or dry air are used as the purge gas. The purge gas flows through the filter and the throttle nozzle, into the purge gas connection (4/1) of the turbomolecular pump. The motor and bearing area of the pump is protected with purge gas.

Since the motor and bearing area is connected to the forevacuum area only by a narrow slit, a pressure higher can build up there than in the forevacuum area. This results in continuous gas flow from the motor area to the forevacuum area. The gas flow prevents aggressive, corrosive gases or dust entering the motor and bearing area.

1.4 Standard specification

The turbomolecular pumps are shipped complete, sealed in a PE bag containing a desiccant.

The maximum effective life of the desiccant is one year.

The electronic frequency converter as well as the connection lines required for operation must be ordered separately.

High-vacuum connection ISO-K

Splinter guard, centering ring with FPM sealing ring, outer ring.

High-vacuum connection ANSI

Splinter guard, FPM sealing ring.

Forevacuum connection port

Centering ring with FPM O-ring and clamping ring.

Both the purge gas port and the venting port are blanked off for shipping.

High-vacuum and fore-vacuum connection are sealed with plastic caps for transport.

PE = Polyethylen

FPM = Fluor caoutchouc, resistant to temperatures of up to 150°C (302°F)

1.5 Technical data

TURBOVAC		340 M	340 M	340 MC	340 MC	340 MCT	341 MCT
High-vacuum connection flange	DN	100 ISO-K 100 CF	160 ISO-K 160 CF	100 ISO-K	160 ISO-K	100 ISO-K	100 ISO-K
Pumping speed for							
N ₂	l·s ⁻¹	270	400	270	400	270	270
He	l·s ⁻¹	370	400	370	400	370	370
H ₂	l·s ⁻¹	340	370	340	370	340	340
Compression for							
N ₂		> 10 ⁹	> 10 ⁹	> 10 ⁹	> 10 ⁹	> 10 ⁹	> 10 ⁹
He		6.4·10 ⁴	6.4·10 ⁴	6.4·10 ⁴	6.4·10 ⁴	6.4·10 ⁴	6.4·10 ⁴
H ₂		2.5·10 ³	2.5·10 ³	2.5·10 ³	2.5·10 ³	2.5·10 ³	2.5·10 ³
Ultimate pressure as to DIN 28 400	mbar	< 10 ⁻¹⁰	< 10 ⁻¹⁰	< 10 ⁻¹⁰	< 10 ⁻¹⁰	< 10 ⁻¹⁰	< 10 ⁻¹⁰
Max. forevacuum pressure at rated speed	mbar	5·10 ⁻¹	5·10 ⁻¹	5·10 ⁻¹	5·10 ⁻¹	5·10 ⁻¹	5·10 ⁻¹
Speed	min ⁻¹	51,600	51,600	43,860	51,600	43,860	43,860
Run-up time	min	3.5	3./2125	3.5	3.5	3.5	3.5
Braking time with/without venting	min	1 / 6	1 / 6	1 / 6	1 / 6	1 / 6	1 / 6
Cooling		not required	not required	water	water	water	water
Cooling connection, hose nipple	mm	-	-	7.5	7.5	7.5	7.5
Cooling water temperature	°C (°F)	-	-	15 - 25 (59 - 77)	15 - 25 (59 - 77)	15 - 25 (59 - 77)	15 - 25 (59 - 77)
Cooling water throughput rate at 15°C/59°F	l·h ⁻¹	-	-	20	20	20	20
Max. bake-out temperature at CF flange	°C/°F	100/212	100/212	-	-	-	-
Mounting position		any	any	any	any	any	any
Weight	ca. kg	16	16	16	32	16	16
Forevacuum connection flange	DN	25 KF	25 KF	25 KF	25 KF	25 KF	40 KF
Purge gas connection flange	DN	10 KF	10 KF	10 KF	10 KF	10 KF	10 KF
Venting connection flange	DN	10 KF	10 KF	10 KF	10 KF	10 KF	10 KF
Recommended backing pump TRIVAC							
at normal operation		D 16 B	D 16 B	-	-	-	-
for purge gas operation		D 25 B/BCS	D 25 B/BCS	D 25 B/BCS	D 25 B/BCS	D 25 B/BCS	D 25 B/BCS

Purge gas valve

Purge gas connection pressure, abs.	1.0 - 1.5 bar
Purge gas	dry nitrogen, argon or similar
Purge gas throughput	
at purge gas pressure 1.0 bar	see
at purge gas pressure 1.5 bar	Fig. 17
Purge gas connection, hose nipple	6 mm (1/4")

Description

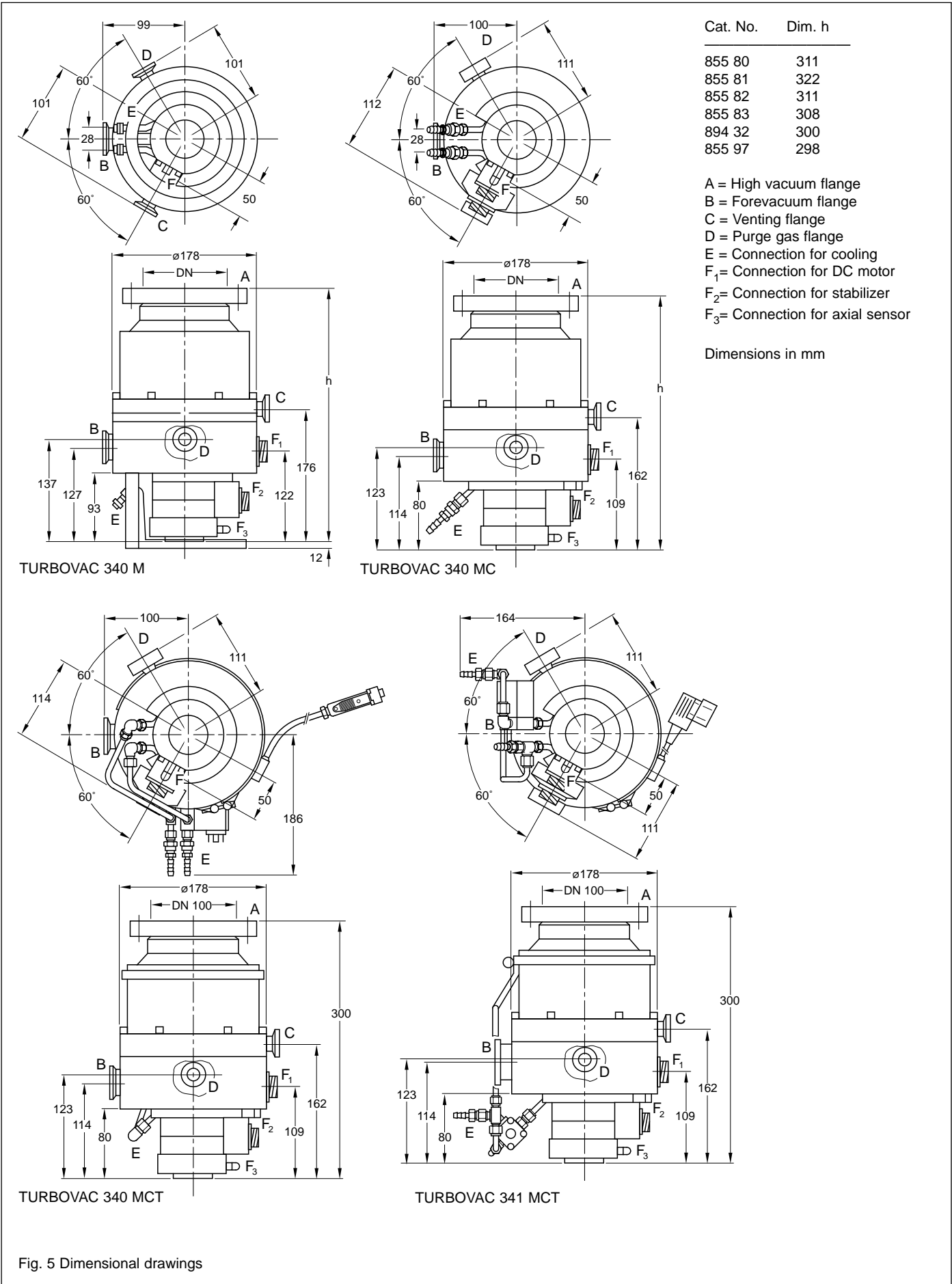

Fig. 5 Dimensional drawings

1.6 Ordering data

TURBOVAC with high vacuum connection flange	340 M	340 MC	340 MCT	341 MCT
DN 100 ISO-K	855 80	894 32	894 33	894 34
DN 100 CF	855 81			
DN 160 ISO-K	855 82	855 97		
DN 160 CF	855 83			
Electronic frequency converter TURBOTRONIK NT	340 M 857 29 (230 V) 857 30 (120 V) 857 31 (100 V)	340 MA 857 32 (120 V)	340 MA 857 32 (120 V)	341 MA 857 34 (208 V)
	+ Accessories for temperature control (see TURBOTRONIK Operating Instructions)			
Connection lines	Set of connection lines 857 70 (3 m long) 857 71 (5 m long) 857 72 (10 m long) 857 73 (20 m long)	Connection line motor 859 10 (3 m long) Connection line bearing 859 11 (3 m long)	Connection line motor 859 12 (20 m long) Connection line bearing 859 13 (20 m long)	

Accessories

Flange heater

DN 100 CF, 230 V	854 27
DN 160 CF, 230 V	854 37
DN 100 CF, 110 V	854 28
DN 160 CF, 110 V	854 38

Purge gas and venting valve

110 V, 50/60 Hz	855 28/48
230 V, 50/60 Hz	855 29/49
24 VDC, 5 W	174 17

Spare diaphragm filter

Spare O-ring; 2 necessary	200 17 876 239 63 110
------------------------------	--------------------------

Power failure airing valve

230 V	174 26
24 V DC, 5 W	174 19

Venting valve, manual

173 24

Adsorption trap, DN 25 KF

854 15

Aluminum oxide; 1.3 kg

854 10

Microfilter

DN 100 ISO-K	887 21
DN 160 ISO-K	887 22

Seal kit

200 91 240

Seal kit + Operating Instructions

200 91 437

2 Installation

When moving the pumps, a lifting fork can be used at the lower surfaces on the base flange; see fig. 6. Having unpacked the TURBOVAC only put it down onto its sealed high-vacuum connection flange. Every other possibility will be too unstable.

Caution

Be careful not to damage the sockets and coolant connections during transportation.

Do not stand below the pump while connecting or removing the TURBOVAC.

The noise level when the pump is running is below 70 dB(A). No acoustic insulation is required.

Warning



Never expose any parts of the body to the vacuum.

Caution

If not equipped with adequate accessories the TURBOVACs are **not** suitable for pumping dusty, aggressive or corrosive media. In case of aggressive or corrosive media the pumps must be operated with purge gas. When pumping media containing dust, insert a microfilter; see Section 1.6. Observe also Section "Compatibility" at the beginning of this Operating Instructions.

2.1 Operating environment

When using the TURBOVAC inside a magnetic field, the magnetic induction at the pump housing must not exceed 5 mT, up to 8 mT is permissible for intermittent exposure; (1 mT (milliTesla) = 10 G (Gauß))

Exceeding this limit value can cause excessive rotor heating due to the eddy currents generated in this situation. It is therefore necessary to provide suitable shielding in such cases.

The standard version of the TURBOVAC is resistant to radiation at levels up to 10^3 Gy. (1 Gy (Gray) = 100 rad)

The ambient temperature must not exceed 45°C (113°F).

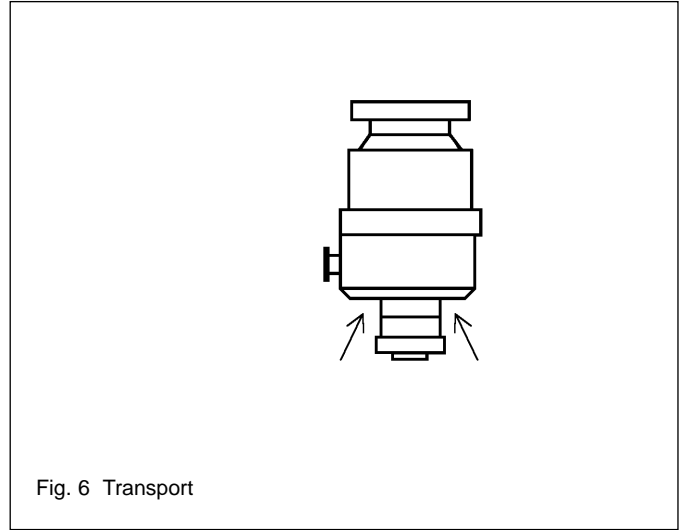

2.2 Connecting the TURBOVAC to the vacuum chamber

Warning



The pump must be securely attached. If the pump were to become blocked, insufficient attachment could cause the pump to break away or allow internal pump parts to be discharged. Never operate the pump (in bench tests, for instance) without its being connected at the vacuum chamber.

If the pump should suddenly seize, the deceleration torque of 880 Nm will have to be absorbed by the system. To accomplish this, 8 clamping screws are necessary for fastening the ISO-K high-vacuum flange:

Clamping bolts made of steel must be torqued down to 35 Nm, those made of stainless steel to 50 Nm.

When installing CF flanges, use only the bolts provided (tightening torque 30 Nm).

You will find the order numbers for the (clamping) bolts in the Leybold-Catalog.

The TURBOVAC is shipped in a sealed PE bag with desiccant. Do not open the package until immediately before installing.

Remove the covers and blanking flanges only just before attaching, to ensure that the TURBOVAC is installed under the cleanest possible conditions.

Pay attention to maximum cleanliness when connecting.

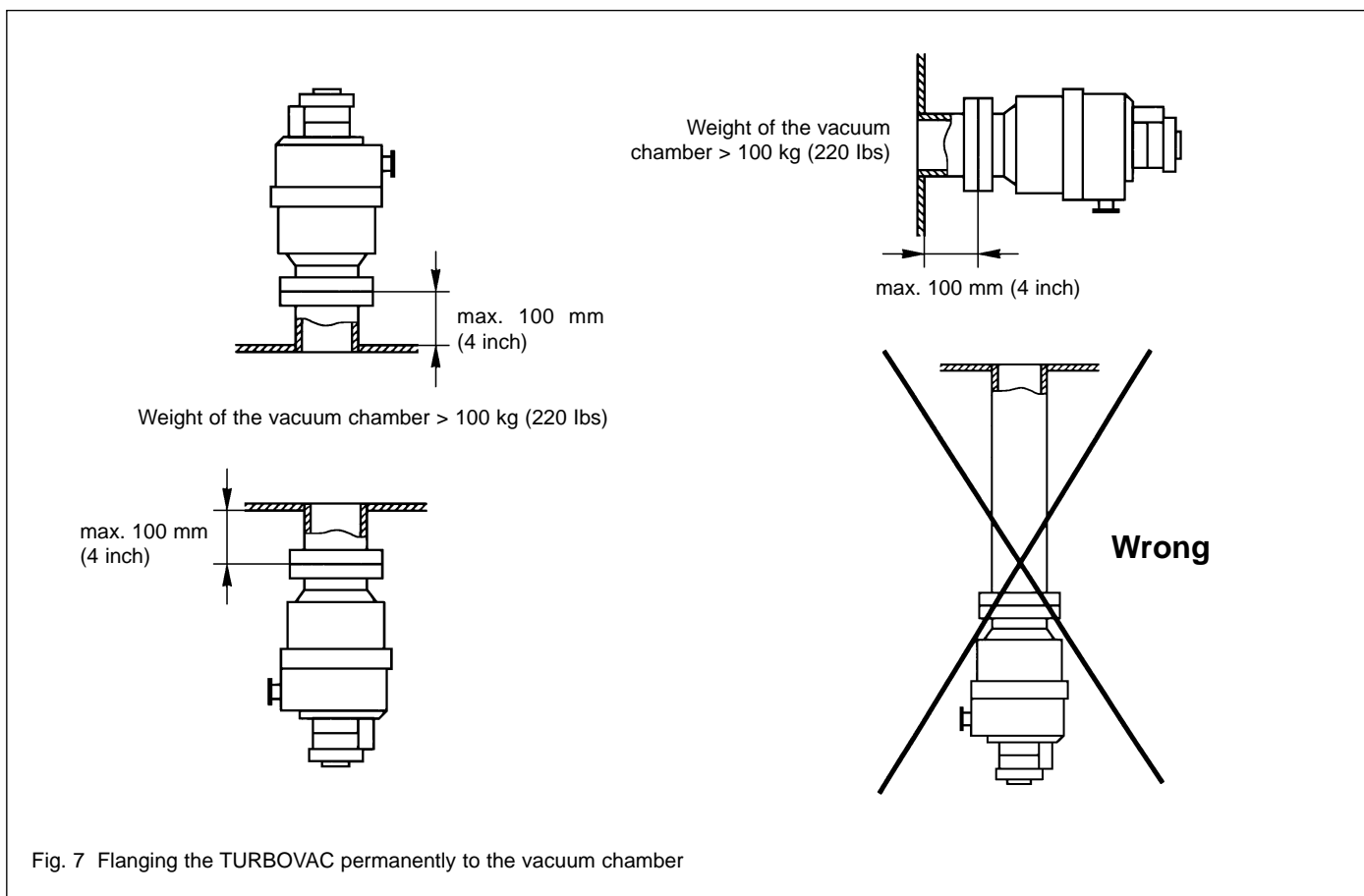

The TURBOVAC runs low in vibration and noise. No vibrations or resonances from outside equipment may be allowed to be transferred to the TURBOVAC.

The TURBOVAC is sensitive to low-frequency vibrations.

Foreign objects entering the pump through the high-vacuum flange can cause serious damage to the rotor. That's why the splinter guard supplied must always be kept installed.

Damages caused during operation without the splinter guard are excluded from warranty.

Mount the TURBOVAC as close as possible to the vacuum chamber. If the TURBOVAC is permanently flanged to a vacuum chamber with a weight exceeding 100 kg, it will not be necessary to secure it in any other way.

In case of lighter vacuum vessels secure the pump additionally.

Use vibration absorbers when flange mounting the pump in order to decouple highly sensitive equipment and to keep external vibrations from being transmitted to the TURBOVAC. In this case the TURBOVAC is to be mounted separately from the vacuum chamber or use vibration absorbers for the attachment to the vacuum chamber; refer to Fig. 8 for details.

Do not use the plastic foot to attach the TURBOVAC.

Flanging on ISO-K-flanges

When connecting the high-vacuum flange, fit the O-ring at the centering ring. The O-ring should be flat and even; it must not be twisted. Then add the outer ring; see Fig. 9.

Use the clamps to join securely the flange and the mating flange.

A collar flange is required when using ultra-high-vacuum sealing washers.

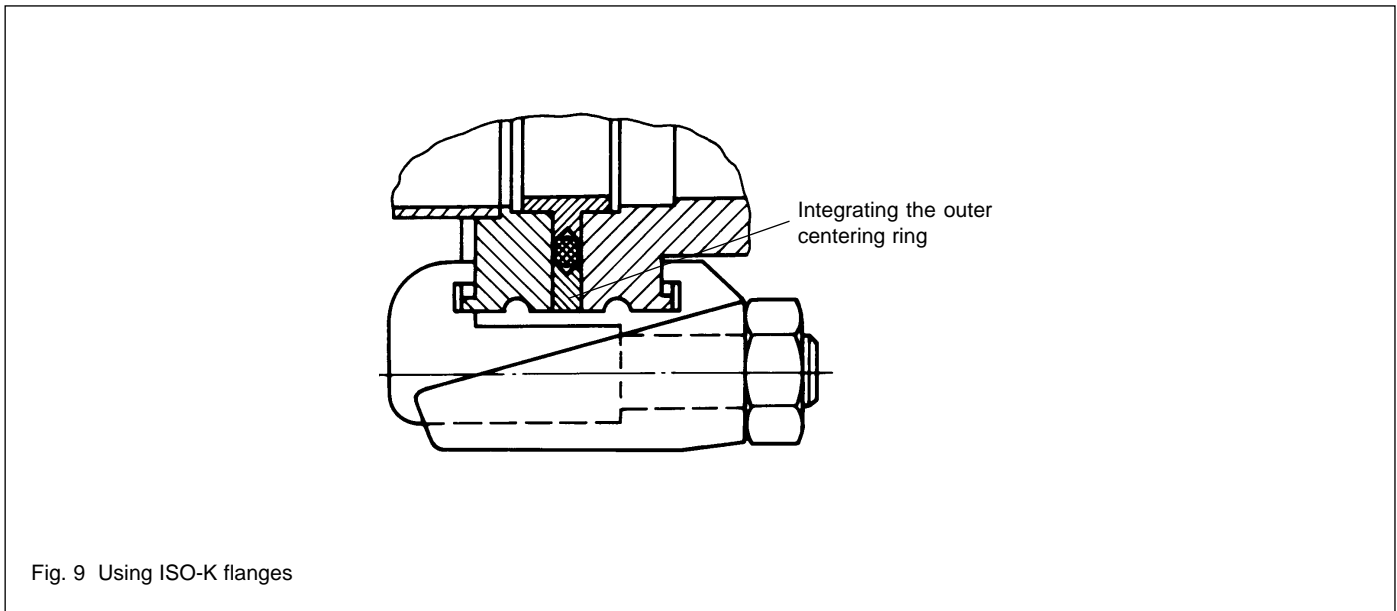
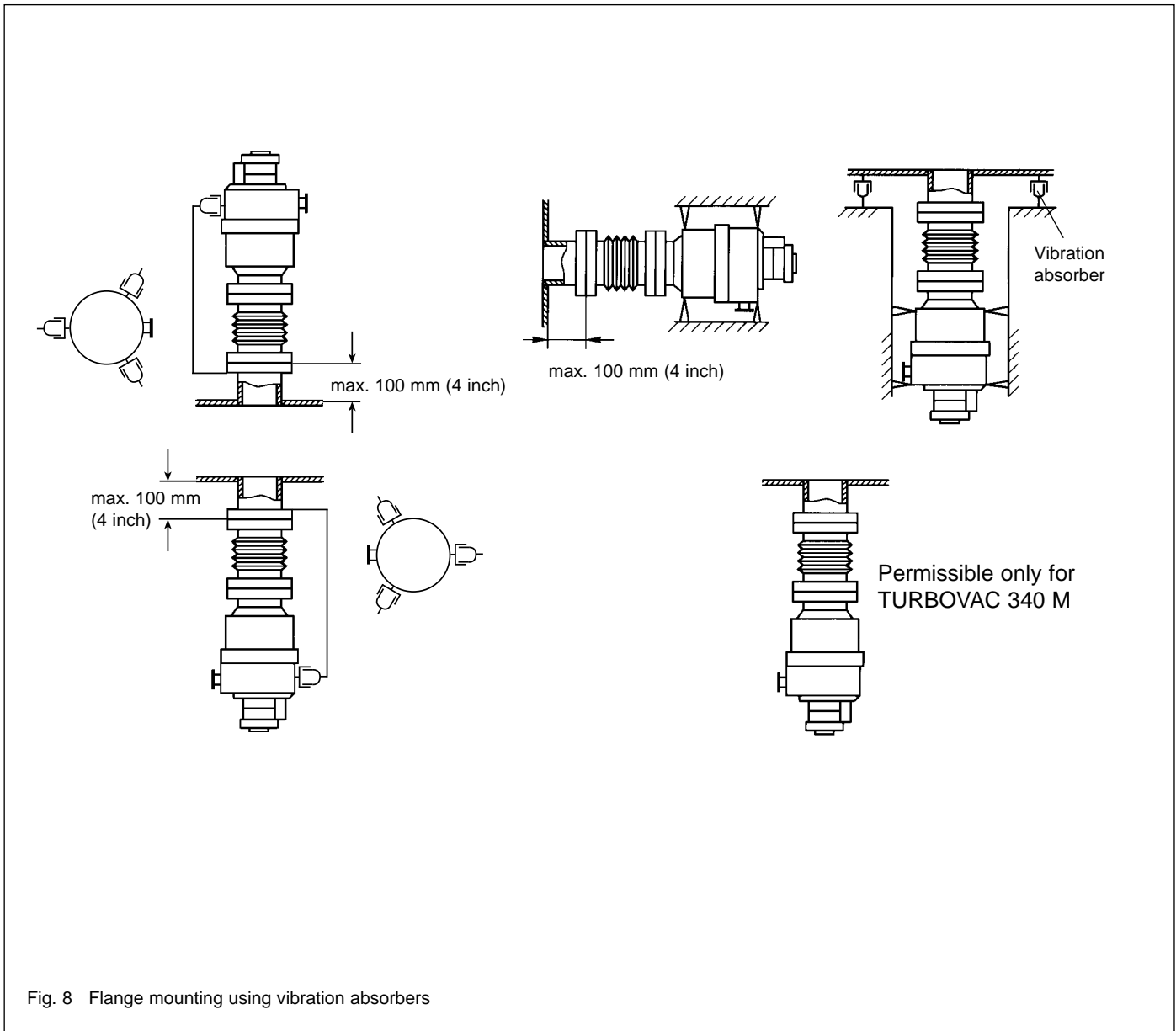

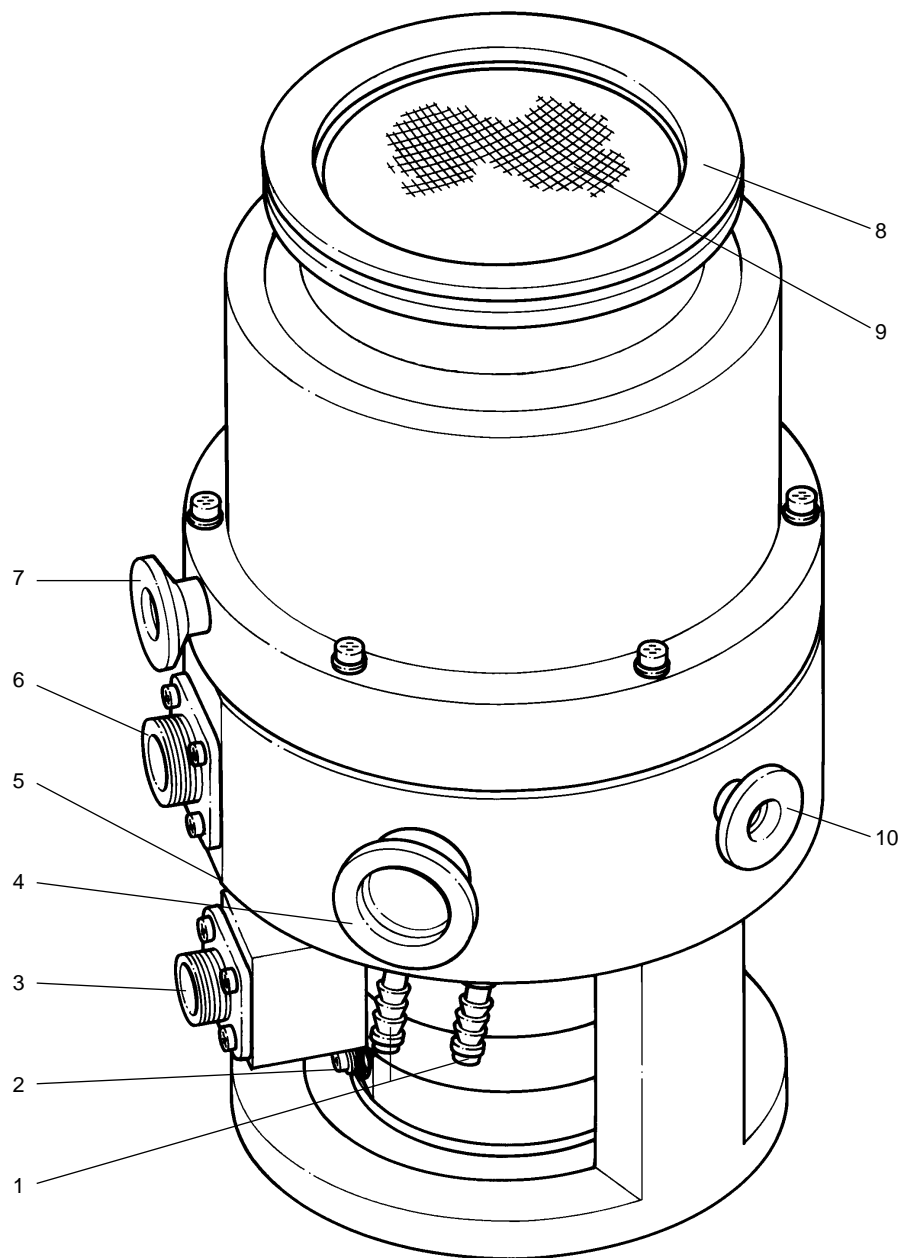

Key to Fig. 10

- 1 Cooling water connection
- 2 Connection for axial sensor
- 3 Stabilizer connection
- 4 Forevacuum connection flange
- 5 Red LED, lights when the magnetic bearing is active
- 6 DC motor connection
- 7 Venting flange
- 8 High-vacuum connection flange
- 9 Splinter guard
- 10 Purge gas connection flange

Fig. 10 Connection fittings

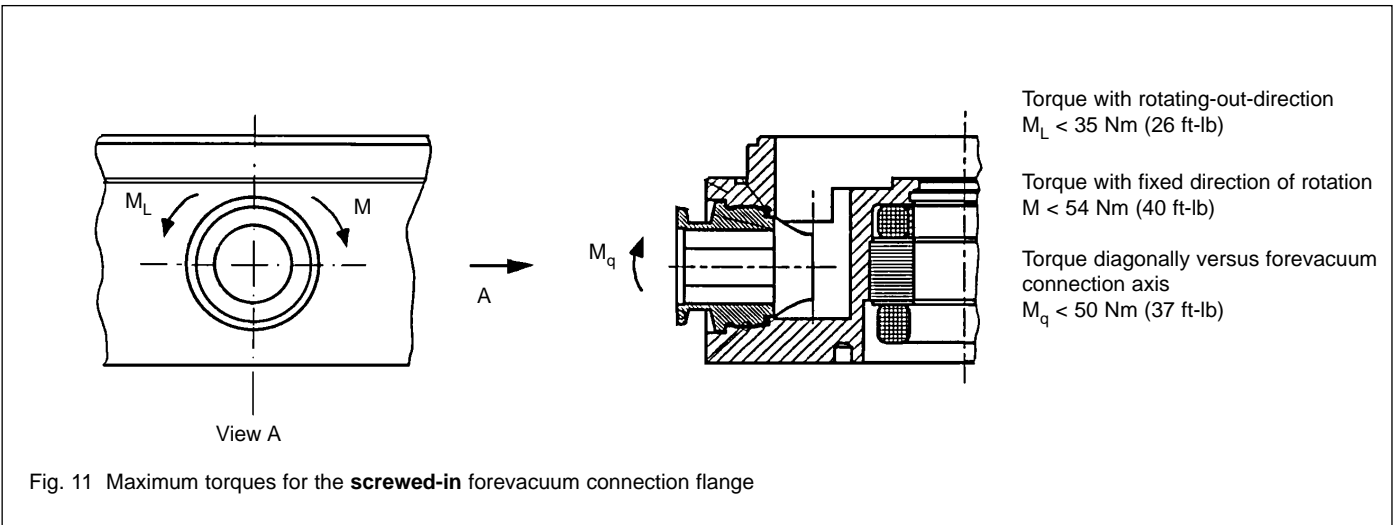

2.3 Connecting the backing pump

A two-stage rotary vane pump is required as the backing pump to support operation of the TURBOVAC.

We recommend using our TRIVAC-B pumps for this purpose.

It is possible to use the dry-compression DRYVAC backing pump for operation of the TURBOVAC. Since the DRYVAC has a higher ultimate pressure than two-stage rotary pumps, the admissible throughput of the TURBOVAC will drop when operating with a DRYVAC.

Connect the backing pump connection flange of the TURBOVAC to the backing pump.

Fig. 12 shows schematically the design of a pump system incorporating a TURBOVAC turbomolecular pump and a TRIVAC backing pump with integral anti-suckback valve.

When using a backing pump not having an integrated anti-suckback valve, a separate safety valve should be used. The safety valve keeps oil from backstreaming from the backing pump and into the TURBOVAC when the system is not running.

We recommend installing a sorption trap in the fore-line to insure that the forevacuum chamber in the TURBOVAC remains largely free of oil vapors during operation, too.

Be sure that there is sufficient vibration decoupling between the TURBOVAC and the backing pump.

The torque on the forevacuum connection flange must not exceed the values shown in Fig. 11.

Warning



The forevacuum line must be tight. Hazardous gases can escape at leaks or the gases being pumped can react with the air or humidity.

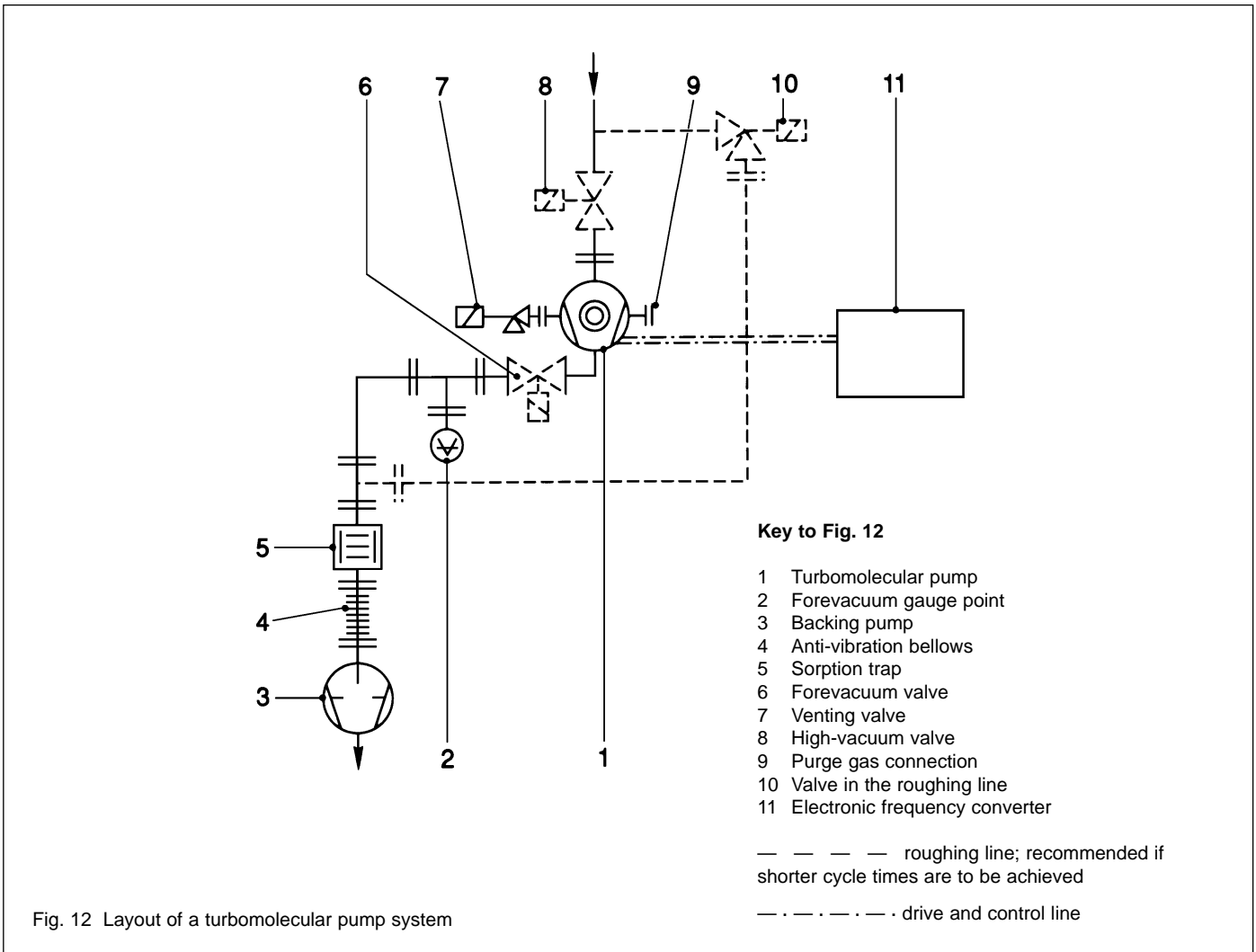

Fig. 12 Layout of a turbomolecular pump system

2.4 Connecting the cooling

In normal operation the TURBOVAC will not require any cooling.

Water cooling will be needed, however,

- for processes where the pump temperature must be regulated,
- for processes where an intake pressure of $p > 10^{-3}$ mbar is maintained over an extended period of time,
- when continuous temperatures in the vacuum chamber exceed 150°C (302°F) and the pump is mounted on top of the vacuum chamber,
- when continuous temperatures in the vacuum chamber exceed 250°C (482°F) regardless of where the pump is mounted.
- when heating of the basic pump flange is necessary or wanted.

The maximum permissible temperature in the vacuum chamber is 300°C (572°F) when operating the TURBOVAC with water cooling.

Use only clean, soft water.

Connect the cooling water feed and drain lines at the hose nipples. Do not mix up water inlet and water outlet. Use hose clamps to keep the hoses from slipping off.

Coolant water pressure may not exceed 6 bar.

The temperature of the cooling water should be between 15°C and 25°C (59°F and 77°F).

Temperatures which are slightly lower (between 10°C and 15°C; 50°F and 59°F) are permissible but there will be danger of condensation on or in the pump.

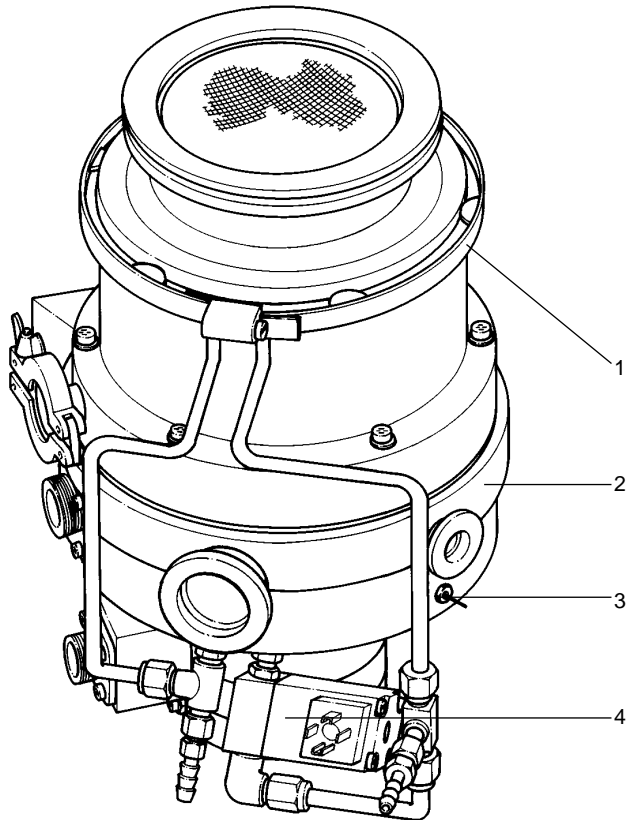

Key to Fig. 13

- 1 Cooling coil for pump housing
- 2 Heating collar
- 3 Temperature sensor Pt 100
- 4 Magnetic valve for water cooling

Fig. 13 TURBOVAC 341 MCT; 340 MCT similar

Slightly higher temperatures (between 25°C and 30°C; 77°F and 86°F) are also acceptable and present no hazard to the pump. Considerably higher temperatures may cause a drop in performance, since the TURBOTRONIK will slow down pumping speed if temperatures are too high.

The temperature control (TCU) on the TURBOTRONIK MA may indicate the operation status FAILURE.

Turn off the cooling water supply before venting the TURBOVAC and when it is not running in order to avoid condensate formation in the pump.

If immediate pump shut-down in case of cooling water supply failure is required, then a flow monitor will have to be inserted in the drain line. For details, refer to the Operating Instructions GA 05.299 flow monitor.

**Temperature control
(for TURBOVAC 340/341 MCT only)**

For connection and operation of the temperature control see also Operating Instructions for the TURBOTRONIK.

Plug in the connection line heating collar - TURBOTRONIK to the heating collar and at the socket HEATER of the TURBOTRONIK.

Plug in the connection line cooling water magnetic valve - TURBOTRONIK at the cooling water magnetic valve and at the socket COOLER of the TURBOTRONIK.

Screw in the Pt 100 temperature sensor. Maximum torque = 2.5 Nm = 1.8 ft-lb. Insert the plug of the Pt 100 connection line at the socket Pt 100 of the TURBOTRONIK.

Warning



The basic flange heater can become so hot during operation (> 80°C, 176 °F) that they represent a burn hazard: Provide protection against contact with the hot components.

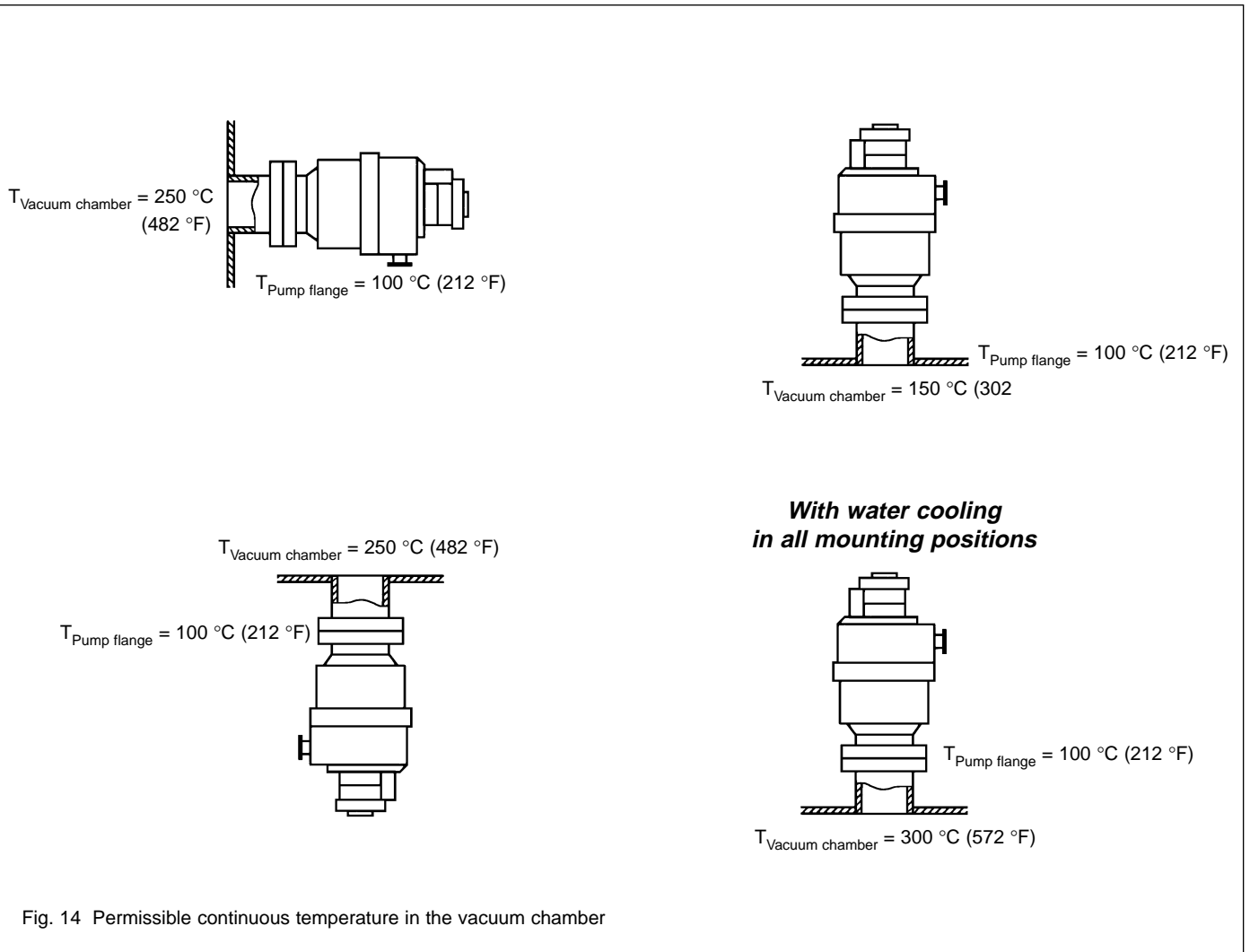

Fig. 14 Permissible continuous temperature in the vacuum chamber

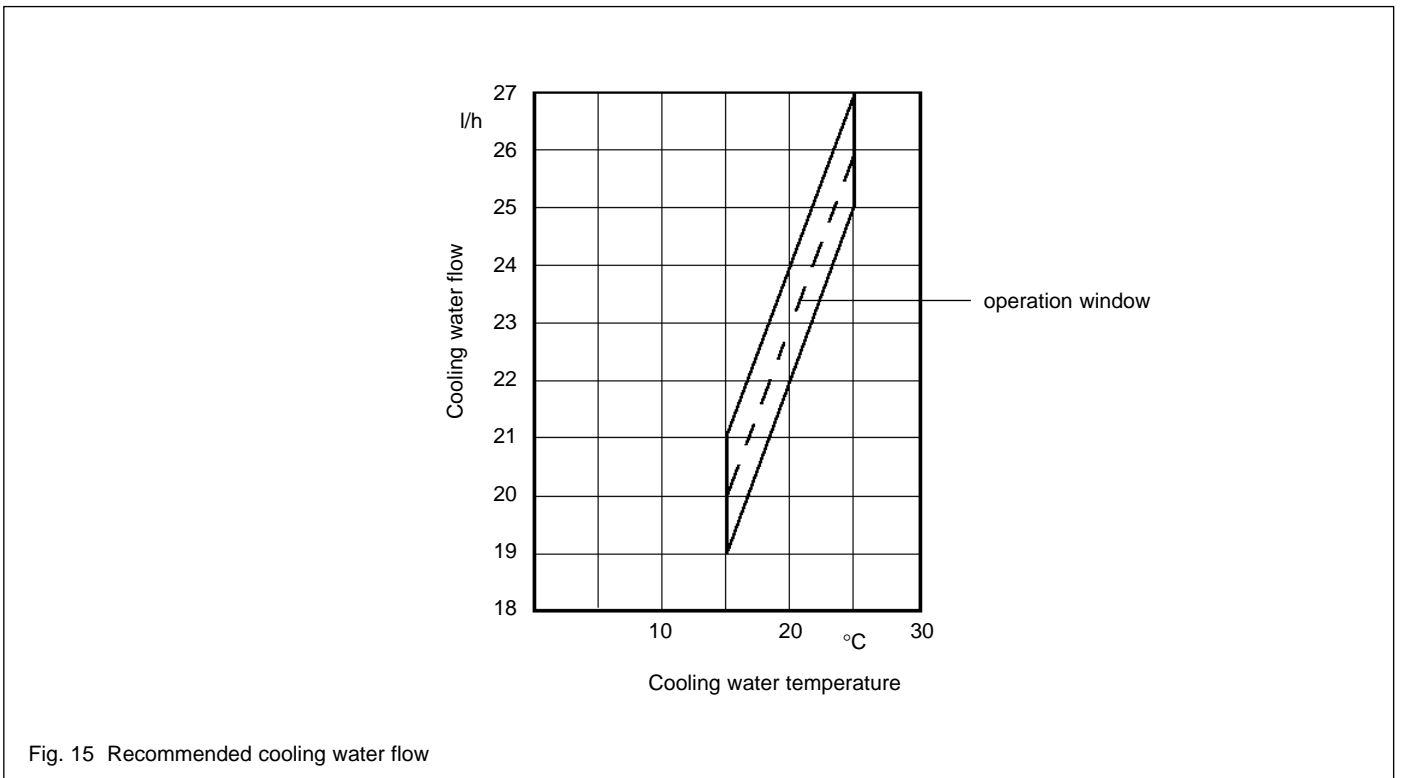

Fig. 15 Recommended cooling water flow

2.5 Connecting the purge gas or power failure airing valve

Connect either a power failure airing valve to venting flange (10/7) or a purge gas valve to the purge gas flange (10/10).

Which of the two valves is used will depend on the nature of the process.

When pumping **clean, non-corrosive gases** you should install the power failure airing valve. This valve keeps the TURBOVAC from continuing to run for a long time after it has been switched off; it also keeps oil from diffusing back from the fore-line.

Connect a purge gas valve when pumping **reactive media**.

Leybold will provide technical support when making the decision as to which media can be pumped with or without purge gas.

When using purge gas, the larger volume of gas at the forevacuum port may require the use of a backing pump providing higher pumping speed; see Section 1.5.

A turbomolecular pump operated with purge gas **must** be vented through the purge gas connection when switched off; hazardous gases may otherwise enter the motor and bearing area.

Connection of the purge gas valve

Flange the purge gas valve directly onto the purge gas connecting flange (10/10), (16/1) of the pump.

The arrow on the valve must point in the direction of flow of the purge gas, i.e. towards the pump.

The pin (16/10) must be in the withdrawn position, and with the valve fitted must also point towards the pump. If the pin is pushed in, the bypass of the purge gas valve cannot be opened. In this case, the valve operates as a simple purge gas valve, without the venting facility.

Connect the purge gas hose to the hose nozzle (16/6) and secure using a hose clip.

Set the purge gas pressure at the inlet of the purge gas valve to 1.0 - 1.5 bar absolute pressure (0.0 psig to 7.5 psig).

When taking purge gas from a pressure tank or a central supply system, use only combined pressure reducing and regulating valves with flow meters which can supply both the low purge gas flow and the considerably larger ventilation gas volumes.

Electrical connection must only be performed by a qualified electrician in accordance with the local regulations.

Release the M3 retaining screw and withdraw the plug (16/9).

Connect the 3-core mains lead.

Replace the plug and secure.

The venting bypass (16/7) is open when de-energized.

The purge gas channel (16/2) is permanently open.

Connect the purge gas valve to the TURBOTRONIK.

Key to Fig. 16

- 1 Purge gas connecting flange
- 2 Throttle nozzle
- 3 Sintered metal filter
- 4 O-rings
- 5 Diaphragm filter
- 6 Hose nozzle
- 7 Venting bypass
- 8 Solenoid valve
- 9 Plug
- 10 Pin

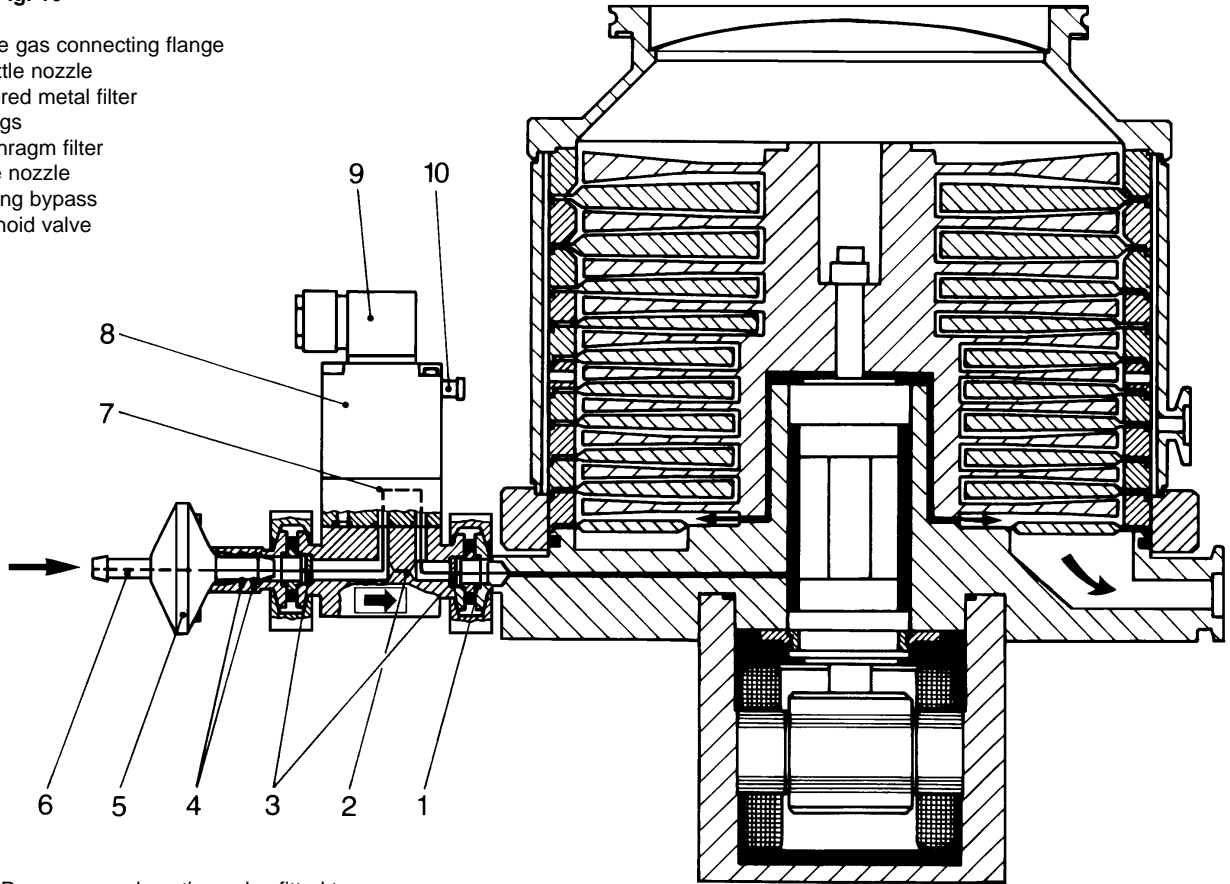

Fig. 16 Purge gas and venting valve fitted to a TURBOVAC (schematic)

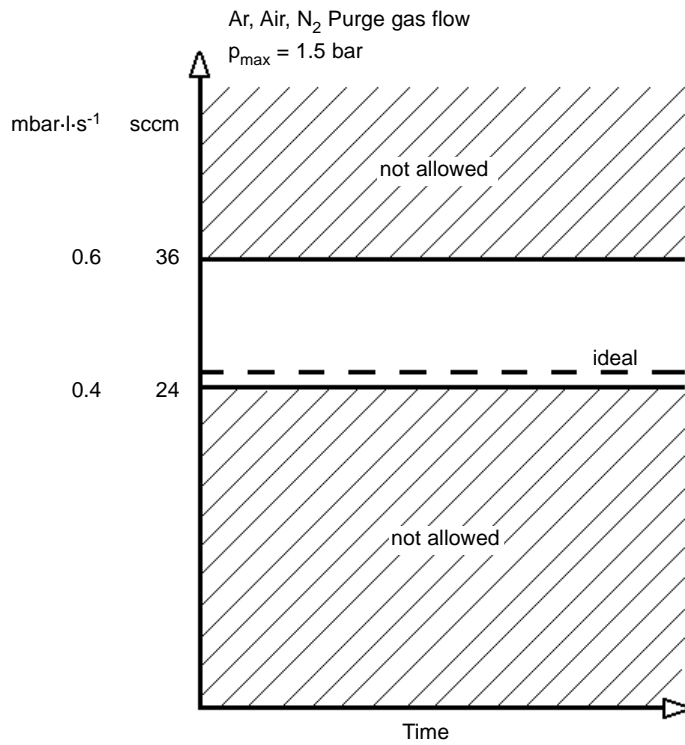

Fig. 17 Recommended purge gas flow

2.6 Attaching the flange heater

(only for pumps with CF flange)

The flange heater is used to bake out, under automatic control, the high-vacuum port at the TURBOVAC and the mating flange on the vacuum chamber.

The flange heater is to be mounted directly to the high vacuum intake flange (10/8) of the TURBOVAC. This is to be done when the pump is flange-mounted.

Warning



The flange heater can become so hot during operation (> 80°C, 176 °F) that they represent a burn hazard. Provide protection against contact with the hot components.

2.7 Connecting the TURBOTRONIK

Refer to the TURBOTRONIK Operating Instructions for details regarding its mounting, connection and operation.

The electronics for the magnetic bearings will have to be adjusted to accommodate the particular pump mounting orientation; information on this is given in the TURBOTRONIK Operating Instructions.

Warning



The pump may be operated only with a suitable frequency converter and connector cables.

Peak voltages of up to 130 V may be present at the connector line between the frequency converter and the pump; mains voltage is present at the fan, the valves and their feed leads.

Route all cables so as to protect them from damage.

The protection rating for the connectors is IP20.

Do not expose the pump, the frequency converter or the connections to dripping water.

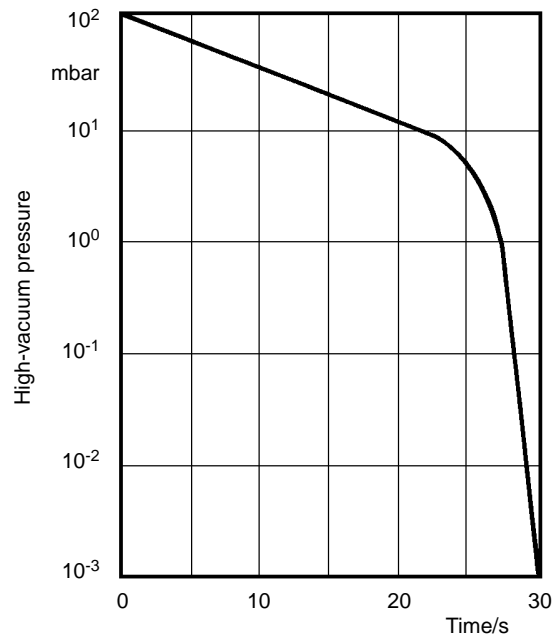

Fig. 18 Minimum pump out time for the TURBOVAC

3 Operation

3.1 Switching on

First of all, open the purge gas supply, then press the START button at the TURBOTRONIK; see the TURBOTRONIK Operating Instructions.

In case of corresponding connection the temperature control and the backing pump will be activated when switching on the TURBOTRONIK.

The backing pump and the TURBOVAC can be switched on simultaneously. In such a situation the TURBOVAC serves from the very outset as an effective baffle.

If the TURBOVAC is to be switched on after a certain delay period, pre-evacuation can take place through the TURBOVAC even though it is not running.

Do not suddenly expose the TURBOVAC to an already evacuated vacuum chamber. The pressure surge may cause the rotor to make contact with the touch-down bearings. This will cause increased wear.

The pump may make noise during the run-up and run-down phases. This happens when, in the lower speed range, the touch-down bearings are touched intermittently. This has neither an influence on the pump nor on the process.

3.2 Operation

The magnetic bearing in the TURBOVAC are immune to wear. In addition to the magnetic bearings, the TURBOVAC is equipped with touch-down bearings which protect the rotor against mechanical contact with the stator if the pump is subjected to external shock loading and when the pump is switched off. These touch-down bearings use no lubricant and thus have a limited service life. Please observe the following in order to obtain maximum service life.

- Avoid shock and vibrations when the pump is running. Shocks perpendicular to the rotation axis are particularly harmful. If the pump should appear to be running in the mechanical bearings continuously while operating at rated speed (and thus making noise), switch off and vent the TURBOVAC; see Section 3.5.

- Avoid a frequent switching on and off.

- Do not disconnect the TURBOVAC and TURBOTRONIK while they are operating; see Section 3.6. A red LED (10/5) lights when the magnetic bearing is active. Only if the red LED has gone off the connecting cable to the TURBOVAC can be disconnected in case of necessity.

Warning



Monitor the purge gas flow continuously. Insufficient purge gas flow can result in:

- Process gases entering the motor and bearing area of the TURBOVAC
- Process gases escaping from the purge gas valve
- Humidity entering the pump.

The purge gas valve is not a shut-off valve.



TURBOVAC with temperature control or flange heater

Warning



The heating collar will be hot during operation. Burn hazard!

Operating failures will be indicated by the TURBOTRONIK; refer to the Section Troubleshooting Guide in the Operating Instructions of the TURBOTRONIK.

3.3 Bake-out

(only for TURBOVAC with CF flange)

If pressures in the range of 10^{-8} mbar and lower are to be achieved the vacuum vessel with its containing components must be baked out. In addition, the TURBOVAC can be baked out using the flange heater provided for this purpose.

The TURBOVAC must be running while baking out.

During the bake-out phase the temperature at the high-vacuum connection port must not exceed 100°C (212°F). Protect the rotor against intensive, direct heat radiation.

When baking out at the forevacuum side, at a sorption trap, for instance, be sure that the components which are flanged on directly are not heated to beyond 80°C (176°F). The backing pump must be in operation.

3.4 Switching off

See the TURBOTRONIK Operating Instructions.

Vent the TURBOVAC before it comes to a full standstill; see Section 3.5.

The TURBOTRONIK controls the venting automatically provided a purge gas valve or a power failure airing valve is connected to the TURBOTRONIK.

Caution

Only switch off the TURBOVAC at the TURBOTRONIK. Switching off through the mains switch is not permissible since it results in an increasing wear of the touch-down bearings.

Press the STOP key at the TURBOTRONIK and wait until the pump has come to a standstill.

Close off the cooling water supply immediately after switching off the TURBOVAC in order to avoid condensate formation in the pump.

The backing pump may be switched off once the TURBOVAC has stopped.

When using TRIVAC-B pumps, the anti-suckback valve will close automatically, closing off the fore-line. On backing pumps without vacuum lock close the valve in the forevacuum line.

If the TURBOVAC has been used for pumping of corrosive gases it should be purged with dry nitrogen for one hour before switching off. During down times of the system take care that neither ambient air nor cleaning agents enter the pump.

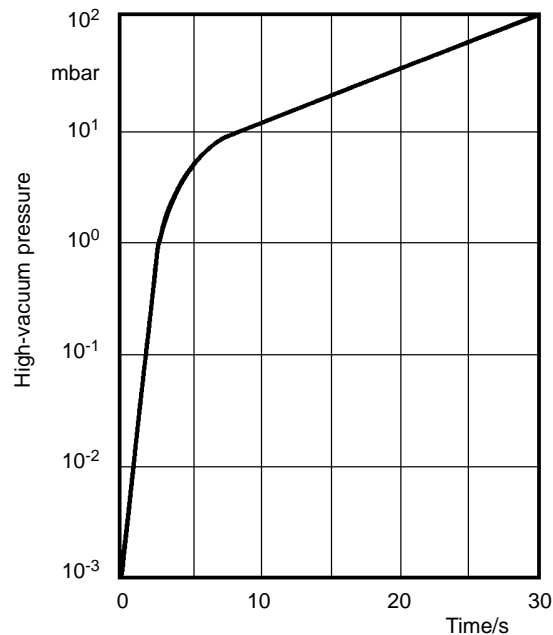

Fig. 19 Curve for safe venting of the TURBOVAC; pressure rise as a function of venting time

3.5 Venting

Vent the TURBOVAC each time it is shut down, in order to prevent any return diffusion of oil vapors out of the fore-line and into the high-vacuum side.

The TURBOTRONIK controls the venting automatically provided a purge gas valve or a power failure airing valve is connected to the TURBOTRONIK.

Use dry nitrogen, for instance, for venting purposes.

There are three methods for venting the TURBOVAC:

1. In processes requiring purge gas, the pump will have to be vented through the purge gas valve when it is shut off.

First switch off the TURBOVAC and then the backing pump; afterwards open the venting bypass.

Leave the venting bypass open as long as hazardous gases from the vacuum chamber or the rotor or stator of the TURBOVAC can enter the motor and bearings' chamber.

If the vacuum chamber is vented with protective gas the bypass must either be opened simultaneously or before.

If the TURBOVAC is vented only via the purge gas valve the prescribed pressure rise curve for the TURBOVAC will be maintained.

Caution

The pressure in the motor and bearing chamber of the TURBOVAC must always be higher than that in the forevacuum chamber.

2. For pumps with CF-connection flange which are operated without purge gas we recommend venting the pump through the venting connection flange. A throttle integrated into the pump eliminates any potential damage to the pump during venting.

3. The pump can be vented from the high-vacuum side.

Caution

Do not suddenly expose the pump to venting. In all cases the values shown in the pressure rise curve in Fig. 19 must be observed.

The pump can be vented while running at full speed.

Do not vent the TURBOVAC via the forevacuum connection as oil vapors could enter the TURBOVAC.

3.6 Power failure - Cable break

If there is a power failure or if the mains plug is accidentally disconnected, the TURBOTRONIK automatically switches over to generator operation to drive the TURBOVAC. In this way the active magnetic bearing control circuits will be kept in operation as the pump runs down, until the rotor seats on the touch-down bearings once it has reached a low speed.

If the connections between the TURBOVAC and the TURBOTRONIK are interrupted, the automatic generator mode and the emergency supply of the magnetic bearing control will be disabled. In this case the rotor will seat directly on the touch-down bearings and runs down making audible running noises. It cannot be excluded that the touch-down bearings would be irreparably damaged in such a situation.

The connection cables between TURBOVAC and TURBOTRONIK are protected against accidental interruption. If, nevertheless, the connection cable is interrupted through mechanical destruction, brake the TURBOVAC until it comes to a standstill via venting.

Once the rotor has set down from the nominal speed on the touch-down bearings, wait about 1 hour before restarting the pump, allowing it sufficient time to cool down.

Caution

The touch-down bearings use no lubricant and thus have a limited service life.

After several rotor run-downs from nominal speed into the touch-down bearings get in contact with the LH after sales service in order to have the bearings' tolerances checked.

4 Maintenance

The TURBOVAC are maintenance-free. Wear only occurs at the touch-down bearings when hard shocks have to be supported.

Regenerate or replace the agent in the sorption trap at regular intervals; for details on the sorption trap please refer to the corresponding Operating Instructions.

4.1 Changing the diaphragm filter of the purge gas and venting valve

The diaphragm filter becomes clogged with time, depending on the degree purity of the purge gas, and must be changed. The purge gas flow must not fall below 90% of the desired value.

Warning



If the purge gas supply has been interrupted during operation of the pump, the diaphragm filter may be contaminated with hazardous substances. The appropriate safety measures must be carried out before any work is performed.



To change the diaphragm filter, first switch off the pump. Having vented the pump sufficiently, shut off the purge gas supply.

Remove the purge gas hose from the hose nozzle (20/6). Withdraw the diaphragm filter (20/5).

We recommend renewing the O-rings (20/4).

Push the new diaphragm filter in as far as to the stop.

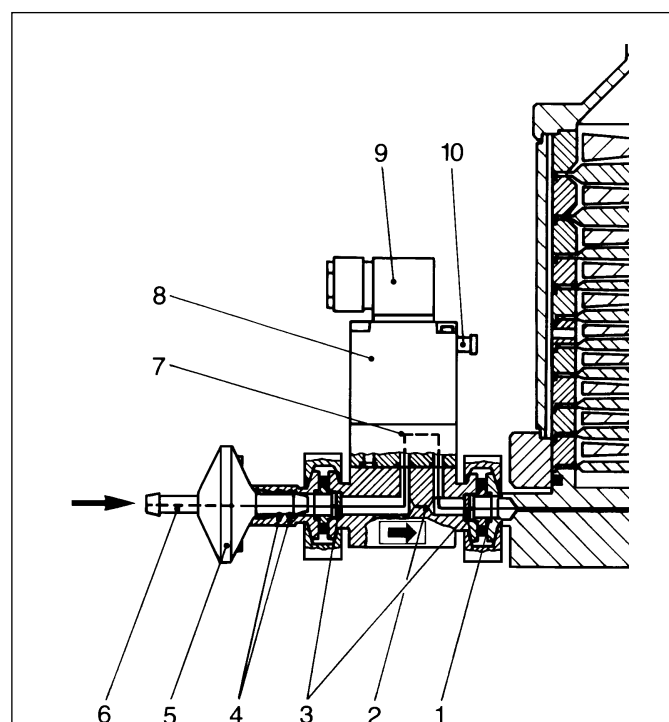

Key to Fig. 20

- 1 Purge gas connecting flange
- 2 Throttle nozzle
- 3 Sintered metal filter
- 4 O-rings
- 5 Diaphragm filter
- 6 Hose nozzle
- 7 Venting bypass
- 8 Solenoid valve
- 9 Plug
- 10 Pin

Fig. 20 Changing the diaphragm filter

Caution

If the used diaphragm filter has been contaminated by process gases, it must be disposed of as industrial waste.

Reconnect the purge gas hose to the hose nozzle.

If you send a purge gas valve to Leybold for repair, indicate any harmful substances which may be in or at the valve.

To do so, use a preprinted form which we'll send to you on request. You find a copy at the end of the Operating Instructions.

4.2 Removing the pump from the system

Press the STOP button at the TURBOTRONIK and wait until the pump has come to a standstill.

Afterwards turn the mains switch to the „0“ position.

The cables between the TURBOVAC and the TURBOTRONIK may be disconnected only after the red LED at the rear of the TURBOTRONIK has gone out.

TURBOVAC pumps which are used in semiconductor processes, for example, are contaminated with process gases. These gases may be toxic and hazardous to health. In addition, deposits with similarly dangerous properties may have formed. Many of these gases and deposits form acids when they come into contact with humid air. This will result in serious corrosion damage to the pump.

To avoid health hazards and corrosion damage when the pumps are detached from the system, use the packing set.

Failure to seal a contaminated TURBOVAC voids the warranty.

The seal kit contains the following

- dry cartridge,
- plastic caps for high-vacuum, forevacuum, venting and purge gas connection flanges.
- plastic adhesive film
- polyethylene bag with cable ties.

Warning



If the pump has previously pumped hazardous gases take the appropriate safety measures before opening the intake or exhaust port.



Use gloves, a breathing mask or protective clothing to avoid skin contact with toxic or highly corrosive substances. Work under a fume hood.



Proceed as follows to seal the turbomolecular pump immediately after removing it from your process.

Purge the pump with purge gas for one hour with the backing pump running. This helps to remove a large quantity of the process gases from the pump.

Remove the pump from the process.

Note

If the venting port was sealed with a blank flange, it isn't necessary to clean, tape and install its cap.

Clean the high-vacuum, backing, venting and purge gas connection flange as necessary for good adhesion of tape.

Place the dry cartridge onto the inlet screen. Don't use loose crystals. The holes of the dry cartridge must point **towards the inlet screen**.

Firmly seal all ports with plastic adhesive film.

Cover each connection ports with its plastic cap.

Place the pump in the plastic bag and secure it with the cable tie.

Attach the fully completed form „Turbopump Field Failure Report“.

Pack the pump so that it cannot be damaged during shipping and so that no contaminants can escape from the packaging.

4.3 Service at Leybold's

If you send a pump to Leybold indicate whether the pump is free of substances damaging to health or whether it is contaminated. If it is contaminated also indicate the nature of hazard. To do so, you must use a pre-printed form which we shall send to you upon request.

A copy of this form is printed at the end of the Operating Instructions: „Declaration of Contamination of Vacuum Equipment and Components“.

Either fasten this form at the pump or simply enclose it to the pump. Don't pack the form with the pump into the PE bag.

This declaration of contamination is necessary to comply with legal requirements and to protect our staff.

Leybold must return any pump without a declaration of contamination to the sender's address.

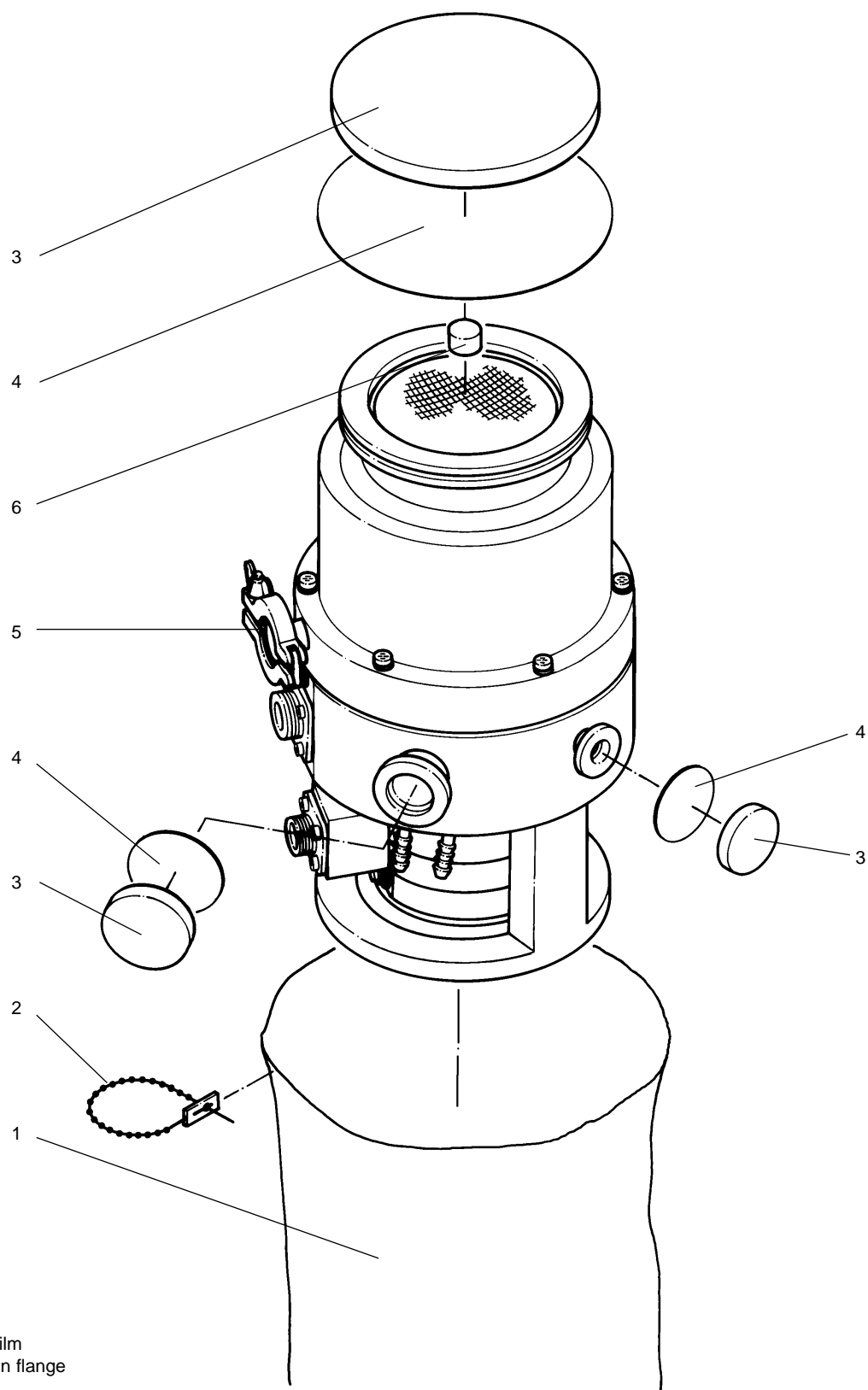
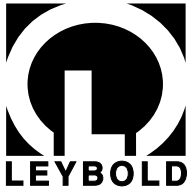

Fig. 21 Sealing the TURBOVAC tightly



Declaration of Contamination of Vacuum Equipment and Components

The repair and/or service of vacuum equipment and components will only be carried out if a correctly completed declaration has been submitted. Non-completion will result in delay. The manufacturer could refuse to accept any equipment without a declaration.

This declaration can only be completed and signed by authorized and qualified staff.

1. Description of Vacuum Equipment and Components

- Equipment type/model: _____
- Code No.: _____
- Serial No.: _____
- Invoice No.: _____
- Delivery date: _____

2. Reason for Return

3. Condition of the Vacuum Equipment and Components

- Has the equipment been used?
yes no
- What type of pump oil/liquid was used? _____
- Is the equipment free from potentially harmful substances?
yes (go to Section 5)
no (go to Section 4)

4. Process related Contamination of Vacuum Equipment and Components:

- toxic yes no
- corrosive yes no
- explosive*) yes no
- biological hazard*) yes no
- radioactive*) yes no
- other harmful substances yes no

*) Vacuum equipment and components which have been contaminated by biological explosive or radioactive substances, will not accepted without written evidence of decontamination!

Please list all substances, gases and by-products which may have come into contact with the equipment:

Trade name Product name Manufacturer	Chemical name (or Symbol)	Dangerous material class	Measures if spillage	First aid in case of human contact
1.				
2.				
3.				
4.				
5.				

5. Legally Binding Declaration

I hereby declare that the information supplied on this form is complete and accurate. The despatch of the contaminated vacuum equipment and components will be in accordance with the appropriate regulations covering Packaging, Transportation and Labelling of Dangerous Substances.

Name of organisation or company: _____

Address: _____ Post code: _____

Tel.: _____

Fax: _____ Telex: _____

Name: _____

Job title: _____

Date: _____ Company stamp: _____

Legally binding signature: _____

Form TMP-1 ... Turbopump Field Failure Report

Field Service IR No.: _____ RMA No. (if returning to factory): _____

Service Center: _____

Customer: _____

Turbopump Model: _____ Turbopump Pump Part Number: _____

Turbopump Serial Number: _____

Complaint: _____

Process: _____

OEM Equipment Name and Model: _____

Process Gas: _____

Was the turbopump replaced? Yes; No.

If yes, replacement pump P/N: _____ replacement pump S/N: _____

Date Installed: _____ Date Removed: _____

Date Received: _____

Date Examined: _____ Examined by: _____

Received Condition: _____

Findings: _____

Cause of Failure: _____

Recommendations: _____

Remarks/Questions: _____

LEYBOLD AG



EEC Manufacturer's Declaration

in the sense of EEC Directive on Machinery 89/392/EWG, Annex IIb



We - Leybold Vacuum GmbH - herewith declare that operation of the incomplete machine defined below, is not permissible until it has been determined that the machine into which this incomplete machine is to be installed, meets the regulations of the EEC Directive on Machinery.

Catalog Numbers: 855 80/81/82/83
894 32, 855 97
894 33
894 34

At the same time we herewith certify conformity with EEC Directive on Low-Voltages 73/23/EWG.

When using the appropriate Leybold accessories, e.g. connector lines, flange heaters, valves, or fans, and when powering the pump with the specified Leybold frequency converters, the protection level prescribed in the EMC Guidelines will be attained

Applied harmonized standards:

- EN 292 Part 1 & 2 Nov. 1991
- pr. EN 1012 Part 2 1993
- EN 60 204 1993

Designation: Turbomolecular pump

Models: TURBOVAC 340 M
340 MC
340 MCT
341 MCT

Applied national standards and technical specifications:

- DIN 31 001 April 1983
- DIN ISO 1940 Dec. 1993

Cologne, December 20, 1995

Handwritten signature of Bischoff in black ink.

Bischoff, Business Area Manager
Turbomolecular pumps

Cologne, December 20, 1995

Handwritten signature of Hofmann in black ink.

Hofmann, Design Department Manager
Turbomolecular pumps

LK.GT.0054.02.12.95

1.80.5.635.54 CD 12.95

Printed in Germany on chlorine-free bleached paper

LEYBOLD AG

Vacuum
Bonner Strasse 498 (Bayenthal)
D-50968 Cologne
Phone: +49 (0221) 347-0
Fax: +49 (0221) 347-1250