

Vakuum-Lösungen

Applikations-
Unterstützungen

Service

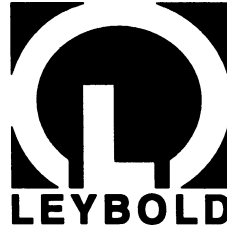

LEYBOLD VAKUUM

GA 05.212/7



TURBOTRONIK

NT 10

NT 12

NT 13

Elektronische
Frequenzwandler

Electronic frequency
converters

Kat.-Nr. / Cat. No.

859 00

859 01

859 04

859 05

859 06

859 07

**Gebrauchsanleitung
Operating Instructions**

idealvac.com
Ideal
vacuum products
(505)872-0037
idealvac.com

TABLE OF CONTENTS

SAFETY-WARNING INFORMATION	4
1 DESCRIPTION	5
1.1 Function and design	5
1.1.1 TURBOTRONIK NT 10	6
1.1.2 TURBOTRONIK NT 12	6
1.1.3 TURBOTRONIK NT 13 with pressure trigger	6
1.2 Technical data	7
1.3 Scope of supply	7
1.4 Accessories	9
2 TURBOTRONIK NT10 CONNECTION AND OPERATION	
2.1 Equipment configuration	10
2.1.1 Supply voltage range	10
2.1.2 Relay assignment	10
2.1.3 Resonance monitoring	10
2.2 Installing TURBOTRONIK	11
2.3 Electrical connection	11
2.3.1 Connecting the relay contacts	11
2.4 Operating modes/remote control	12
1. Operation via the "START" and "STOP" buttons	12
2. Remote control via 2 external pushbuttons	12
3. Remote control via an external switch	13
4. Automatic start when the power is switched-on	13
2.5 Operator control	13
3 TURBOTRONIK NT12 CONNECTION AND OPERATION	
3.1 Equipment configuration	14
3.1.1 Supply voltage range	14
3.1.2 Relay assignment	14
3.1.3 Resonance monitoring function	14
3.2 Installing TURBOTRONIK	15
3.3 Electrical connection	15
3.3.1 Connecting the relay contacts	15
3.4 Operating modes/remote control	16
1. Remote control via 2 external pushbuttons	16
2. Remote control via an external switch	17
3. Automatic start when the power is switched-on	17
3.5 Operator control	17
4 TURBOTRONIK NT13 CONNECTION AND OPERATION	
4.1 Equipment configuration	18
4.1.1 Supply voltage range	18
4.1.2 Relay assignment	18
4.1.3 Resonance monitoring function	18
4.2 Installing TURBOTRONIK	19

TABLE OF CONTENTS

4.3 Electrical connection	19
4.3.1 Connecting the relay contacts	19
4.3.2 Connecting the test sockets	20
4.4 Operating modes/remote control	21
4.5 Operator control	21

5 SETTING THE EQUIPMENT CONFIGURATION

5.1 Selecting the supply voltage range	22
5.2 Withdrawing the PC boards	23
5.3 Locations of the plug-in and jumpers	24
5.4 Relay statuses	24
5.5 Setting the configuration of relay K1	25
5.6 Setting the configuration of relay K2	25
5.7 Setting the resonance monitoring funct.	26
5.8 Jumper field S2	26
5.9 Measuring the motor frequency	27
5.10 Connecting examples for remote control	28

6 TROUBLESHOOTING

EC DECLARATION OF MANUFACTURE	31
--	-----------

EC DECLARATION OF CONFORMITY	32
---	-----------

FACTORY CERTIFICATE	33
----------------------------------	-----------

<i>Fig. 1 TURBOTRONIK NT10.....</i>	<i>6</i>
<i>Fig. 2 TURBOTRONIK NT12.....</i>	<i>6</i>
<i>Fig. 3 TURBOTRONIK NT13.....</i>	<i>6</i>
<i>Fig. 4 Dimension drawings of the Turbotronik NT10, NT12, NT13 ...</i>	<i>8</i>
<i>Fig. 5 Rear panel of the TURBOTRONIK NT10.....</i>	<i>12</i>
<i>Fig. 6 TURBOTRONIK NT 12, pin assignment</i>	<i>16</i>
<i>Fig. 7 TURBOTRONIK NT 13, pin assignment</i>	<i>20</i>
<i>Fig. 8 Voltage at the front panel test sockets</i>	<i>20</i>
<i>Fig. 9 Setting the supply voltage range</i>	<i>22</i>
<i>Fig. 10 Supply voltage selector switch TURBOTRONIK NT12</i>	<i>22</i>
<i>Fig. 11 PC board layouts</i>	<i>24</i>
<i>Fig. 12 - 16 Setting the configuration of relay K1</i>	<i>25</i>
<i>Fig. 17 - 21 Setting the configuration of relay K2</i>	<i>25/26</i>
<i>Fig. 22 Setting the resonance monitoring function</i>	<i>26</i>
<i>Fig. 23 - 26 Jumper field S2.....</i>	<i>27</i>
<i>Fig. 27 Diagram, measuring the motor frequency</i>	<i>27</i>
<i>Fig. 28 Measuring the motor frequency</i>	<i>27</i>
<i>Fig. 29 - 34 Connecting examples for remote control</i>	<i>28</i>

Note

(5/3) = refers to figure. The first digit refers to the number of the figure, the second digit to the position.



Qualified personnel

Proper use and operation



Definition of caution

Definition of warning

Warning about the potential hazards of this equipment

This unit has voltages at hazardous potentials! Death, severe bodily injury or significant material damage can occur if the instructions in this Instruction Manual are not observed. Only appropriately qualified personnel may work with this equipment. This personnel must be knowledgeable about all of the warning information and measures which are specified in this Instruction Manual for the transport, installation, operator control and troubleshooting of the equipment. The successful and safe handling of this equipment requires that it is professionally transported, installed and handled.

Caution

Disconnect the equipment from the supply and lock-out against accidental reclosure before opening-up the equipment. When connecting an external voltage of > 42 V to the terminals of the unit, the VDE safety regulations must be observed!

Caution

This device contains devices which can be destroyed by electrostatic discharge (ESD)!

Qualified personnel are personnel who are either suitably qualified electricians or have had some form of electrical training in the sense of EN 60204 Part 1, 3.55 and 3.30.

The electronic frequency converters NT10, NT12 and NT13 are exclusively used for feeding turbo-molecular pumps

- ◆ TURBOVAC 50 (Cat. No. 854 00, 854 01, 854 02 and 853 99)
- ◆ TURBOVAC 50D (Cat. No. 856 60, 856 61, 856 62 and 856 63)

The connecting cables, specified under Section 1.4 must be used to connect-up the above mentioned turbo-molecular pumps.

The EC manufacturer's declaration becomes null and void if the unit is changed without consulting us beforehand, or if it is used for another purpose than it was originally designed for!

It is not permissible to make changes or modifications on the equipment for safety reasons. We retain the right to change the mechanical design and revise the technical data.

Caution: Is specified for working- and operating procedures which must be precisely maintained in order to avoid personnel being subject to hazards.

Warning: Refers to working- and operating procedures which must be precisely maintained in order to prevent the equipment being damaged or destroyed.

Keep the Instruction Manual in a safe place for future use!

1.1 Function and design

Application and function

The electronic TURBOTRONIC NT 10, NT 12 and NT 13 frequency converters are used to drive TURBOVAC 50 and 50 D. They differ as follows:

- the housing
- the connectors,
- operator control possibilities
- scope of supply, and
- in the configuration in which they are supplied.

The electronic frequency converters convert the single-phase supply voltage into a three-phase AC voltage to control the TURBOVAC induction motor.

The frequency converters operate according to a specific cycle: The motor is driven for approximately 1 second and the monitoring measurements are executed in the following 0.1 seconds.

Operating statuses

The following operating statuses are displayed using LEDs:

- supply voltage present
- run-up
- standard and
- fault Optionally

Various signals are available via 2 relay outputs.

Run-up and operation

After the start, the pump continuously accelerates with the maximum current. This is identified by the yellow LED „ACCEL“ (acceleration) which is lit. The green „NORMAL“ LED is lit and the „ACCEL“ LED goes dark when approximately 90% of the rated speed is reached.

The speed is continuously monitored and controlled. When the speed cannot be maintained, even at the maximum current, as a result of external influences, e.g. excessive gas feed, the speed decreases and the pump continues to operate.

When a rotational frequency of approximately 500 Hz is fallen below, the „ACCEL“ LED lights-up on the frequency converter. The TURBOTRONIK now attempts to accelerate the pump up to its reference frequency.

Outputs

The frequency converter outputs are no-load- and short-circuit proof.

The electronic TURBOTRONIK frequency converters can be connected to external open-loop control- and monitoring devices with electrical isolation.

The cable connections between TURBOTRONIK - TURBOVAC can be a maximum of 100 m.

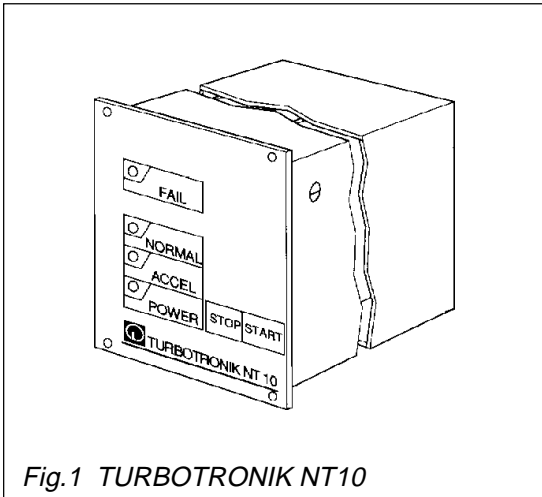

Fig.1 TURBOTRONIK NT10

1.1.1 TURBOTRONIK NT 10

Desktop unit or
for mounting in a rack 1/4 19", 3 HE

Front panel: Membrane keypad, 4 LEDs, "START" and "STOP" keys

Housing: Extruded aluminum housing.

Rear panel: 10-pin Phönix connector for remote monitoring and control, 5-pin connector to connect the TURBOVAC, 3 m long power cable with protective contact connector and

▶ power switch

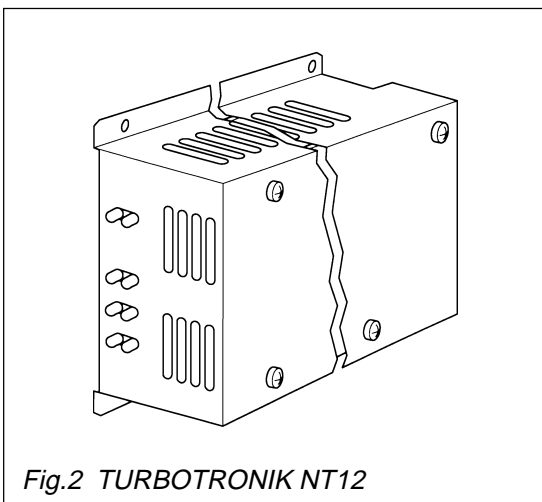

Fig.2 TURBOTRONIK NT12

1.1.2 TURBOTRONIK NT 12

Chassis unit

Front panel: 4 LEDs.

Housing: Sheet-steel housing with screen plate

Rear panel: Plug connector strip in accordance with DIN 41 612 with 15 contacts to connect the TURBOVAC, the power and the remote control and monitoring.

▶ **Note**

A switch must be installed on the system side to allow the equipment to be isolated from the supply!

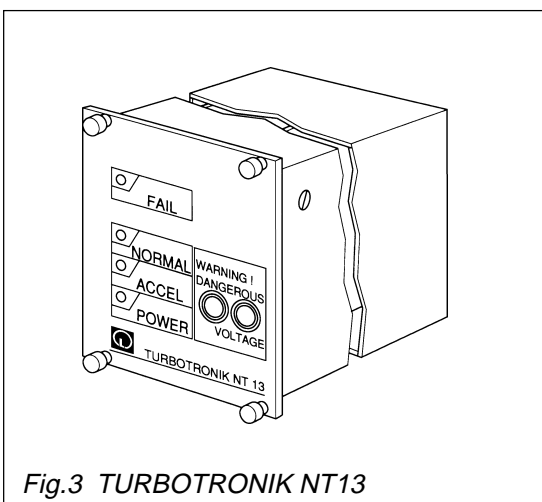

Fig.3 TURBOTRONIK NT13

1.1.3 TURBOTRONIK NT 13 with pressure trigger

For mounting in rack ¼ 19" rack, 3 HE

Front panel: Membrane-coated front panel with 4 LEDs and 2 test sockets

Housing: Extruded-aluminum housing.

Rear panel: Sheet steel, plug connector strip in accordance with DIN 41 612 with 15 contacts to connect the TURBOVAC, the power and the remote control and monitoring.

▶ **Note**

A switch must be installed on the system side to permit the equipment to be isolated from the line supply!

1.2 Technical data	
Supply	Supply voltage ranges 100-140 V AC, -10%/+16% Can be switched-over to 200-240 V AC, ±10% Supply frequency 50/60 Hz Line fuse (F1 internal) T 1A / 250 V Rated speed of the TURBOVAC 72,000 RPM = 1200 Hz
Power consumption	Briefly when accelerating up to 64 VA (45 W) Continuously in operation (rated speed) 35 VA (18 W) Idle operation (no-load) 6 VA (3 W)
Outputs	Voltage 3 x 150 V Supply frequency 1200 Hz Frequency range of the output voltage 220-1250 Hz
Ambient temperature	in operation 0°C - 40°C storage -40°C to +85°C
Max. load capability of the relay contacts	Switching voltage ≤ 250 V AC, ≤ 30 V DC Switching current ≤ 6 A AC, ≤ 5 V DC Switching power for DC ≤ 150 W Switching power for AC ≤ 1500 VA
Degree of protection	The units have degree of protection IP20 in accordance with EN 60 529. An increased degree of protection, e.g. IP54 can only be realized by mounting the units in other housings.
Weight	TURBOTRONIK NT 10 1.5 kg TURBOTRONIK NT 12 1.5 kg TURBOTRONIK NT 13 1.5 kg
Dimensions and housing dimensions (refer to Fig. 4)	TURBOTRONIK NT 10 1/4 19", 3 HE TURBOTRONIK NT 13 1/4 19", 3 HE

1.3 Scope of supply

The connecting cable to the TURBOVAC is **not** included in the scope of supply!

1.3.1 TURBOTRONIK NT 10

TURBOTRONIK NT 10, miniature fuses, mating connector for the Phönix connector (control terminal strip X10), attachable feet for desktop operation, 4 adhesive feet, four M 3x8 screws, the power cable is permanently attached.

1.3.2 TURBOTRONIK NT 12

TURBOTRONIK NT 12, miniature fuses

1.3.3 TURBOTRONIK NT 13

TURBOTRONIK NT 13, miniature fuses, 4 screws for rack installation

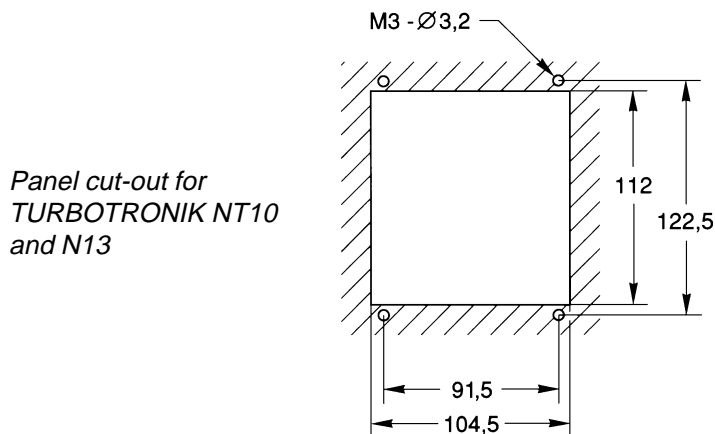
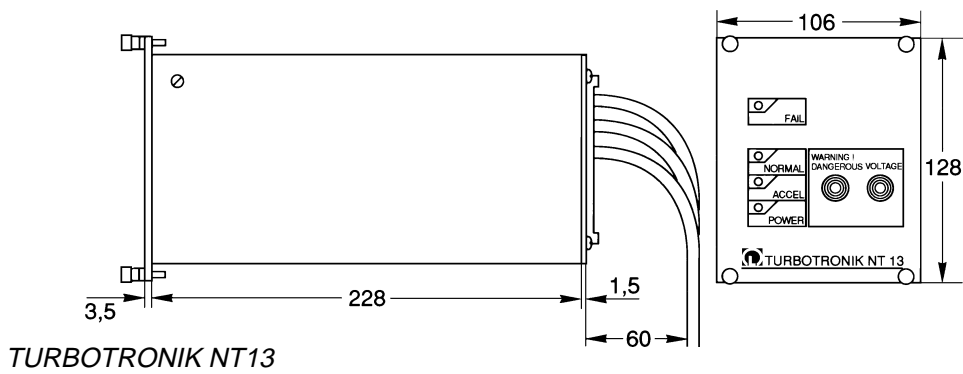
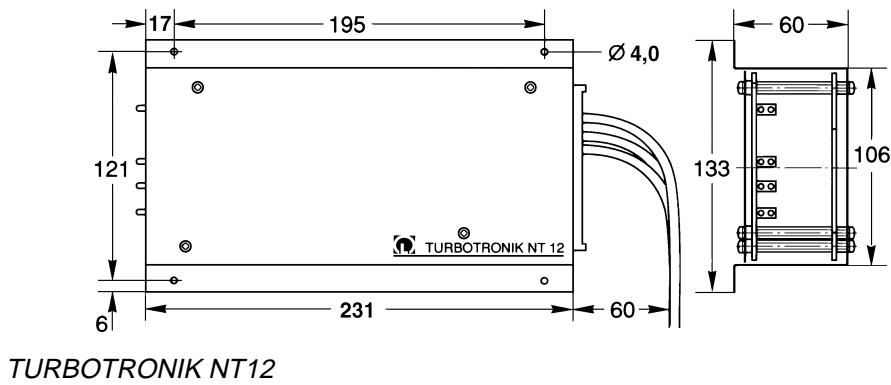
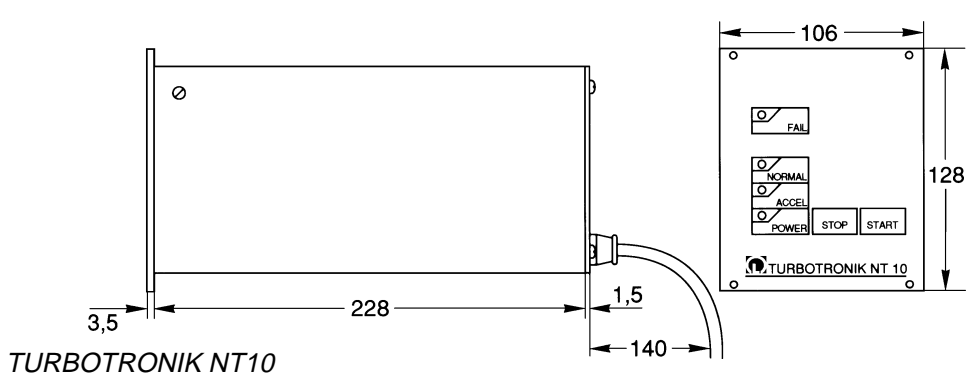

Fig. 4 Dimension drawings of the TURBOTRONIK NT10, NT12, NT13

1.4 Accessories

Ordering information

	Cat. No.
Electronic frequency converter	TURBOTRONIK NT 10
	200 V - 240 V 859 00
	100 V - 120 V 859 01
	TURBOTRONIK NT 12
200 V - 240 V 859 04	
100 V - 120 V 859 05	
	TURBOTRONIK NT 13
200 V - 240 V 859 06	
100 V - 120 V 859 07	

Connecting cable

Connecting cable from the TURBOVAC to

TURBOTRONIK NT10

3 m long 857 50
5 m long 857 51
10 m long 857 52
20 m long 857 53

TURBOTRONIK NT12

3 m long 857 54

TURBOTRONIK NT13

1 m long 857 56

A mating connector for the plug connector strips X11 including 15 contact pins are supplied with the connecting cable (only NT12, NT13).

Accessories to mount NT 12 in a rack on request.



The equipment may only be connected-up by a suitably trained electrician or under his supervision in accordance with the valid IEC (international), EN (European) and/or domestic guidelines.

Caution

The TURBOTRONIK NT10 has parts and components at hazardous voltage levels. **Before** carrying out any work with the equipment open, it must be isolated from the line supply and locked-out against accidental re-closure.

2.1 Equipment configuration

2.1.1 Supply voltage range

TURBOTRONIK NT10 can be operated with two supply voltages; between 200-240 V or between 100-120 V.

It is set in the factory for a specific supply voltage range which can be identified by the Order No., refer to the Catalog No. under Section 1.4.



Caution

TURBOTRONIK will be damaged if it is connected to the wrong line supply voltage.

Refer to Section 5.1 when changing-over the supply voltage range.

2.1.2 Relay assignment

TURBOTRONIK NT10 has 2 relays; the "NORMAL" (K1) and "FAIL"/ fault (K2) signals are available at its outputs.

Relay K1 is available as changeover contact. The relay function of K2 can be changed using a jumper. Further, relay K2 can be changed over from an NO contact to an NC contact.

Relay **K2** can be used to control the "pre-vacuum pump". In this case, it is active after the start, and inactive after the TURBOVAC has been brought to a standstill, also refer to Section 5.

2.1.3 Resonance monitoring

TURBOTRONIK NT 10 has a resonance monitoring function for the TURBOVAC 50D. The resonance monitoring function shuts down the drive and displays a fault if the pump remains in the speed range between 45,000 and 55,000 RPM for longer than approximately 1 minute. When shipped, the resonance monitoring function is active, and can be disabled when operating the TURBOVAC 50; also refer to Section 5.6.

Caution

If TURBOVAC 50D is used without the resonance monitoring function, this can lead to bearing damage.

Status when shipped

Changing-over the relay assignment

K2: Contrlling the pre-vacuum pump

Tip

We recommend that if you change the relay assignment or if the resonance monitoring is disabled, then this should either be noted on the equipment itself, or documented in the associated Instruction Manual.

Operating as desktop unit**Rack installation****2.2 Installing TURBOTRONIK**

TURBOTRONIK NT 10 is supplied in a housing as desktop unit. When required, feet can be attached to the lower side. The feet can be attached by inserting them into the lowest groove of the corner strip from the back and pushing them towards the front until they lock-in. Attach the four adhesive feet to the lower side of the equipment feet and in the rear area of the unit.

TURBOTRONIK NT 10 can be installed in a rack. Ensure that it is adequately ventilated. In operation, it is not permissible that the ambient temperature exceeds 40°C.

If the rear panel of the TURBOTRONIK is no longer accessible after it has been installed, switch-on the power switch (5/2) beforehand.

Four holes in the front panel are used to install it in 19" racks.

2.3 Electrical connection

Insert the connecting cable to the TURBOVAC at the socket (5/4) and at the TURBOVAC motor. The connector is secured using the screw provided.

Note

It is impossible to incorrectly insert the pump connector as a result of the different pins. When correctly assembled, this plug connection has degree of protection IP65.

If you assemble your own connecting cable, observe that it can be a maximum of 100 m long. Only use double-screened cables with the appropriate insulation. If you require any further information, please inquire.

**Protective conductor connection****Caution**

High discharge currents! If the connecting cable between the TURBOVAC and TURBOTRONIK is longer than 10 m, protective ground must be connected to both units.

Connect the grounding cable (5/3) to the central grounding rail. Connect the supply using the power cable (5/1).

2.3.1 Connecting the relay contacts

The "NORMAL" and "ACCEL" (acceleration) operating statuses can be interrogated at pins 5,6,7.

- Pins 6-7 closed: "NORMAL"
- Pins 5-6 closed: "ACCEL", standstill or fault

When a fault occurs, pins 9 and 10 are jumpered (NO contact).

► The relays can be assigned differently, also refer to Section 2.3.2 and Chapter 5.



The supply voltage or functional low voltage can be connected to the relay contacts. Observe the appropriate safety regulations.

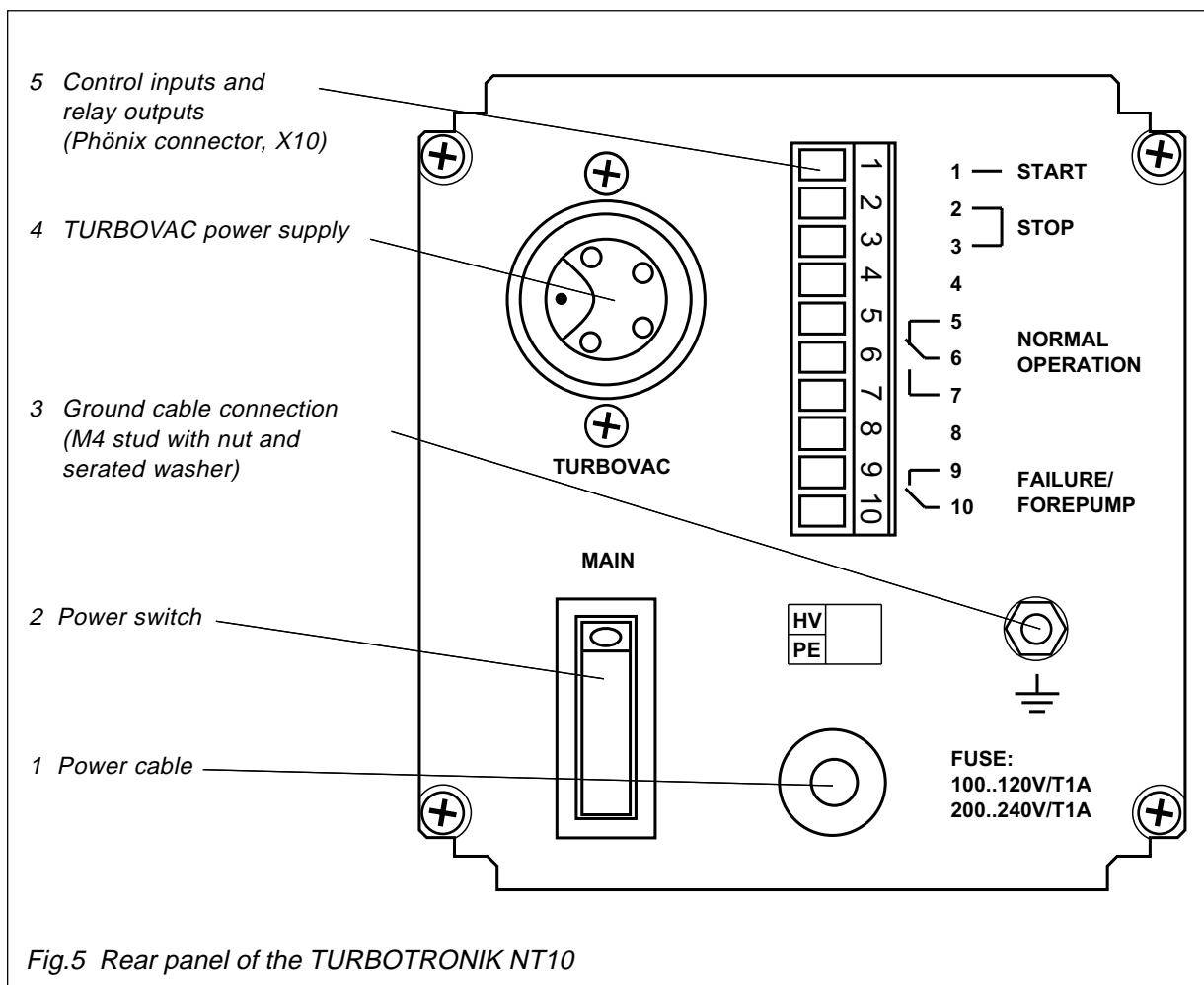

2.4 Operating modes/remote control

When TURBOTRONIK NT 10 is shipped, **4 operating modes** are possible by appropriately connecting inputs 1, 2 and 3 of control connector X10 at the rear panel of the TURBOTRONIK.

The equipment configuration can also be changed-over to other functions using plug-in jumpers and other jumpers; also refer to Section 5.

Refer to Section 5.9 for circuit examples for remote control.

Operating mode 1

1. Operation via the "START" and "STOP" buttons

Jumper between pins 2 and 3 (status when shipped). The TURBOVAC is started and stopped using the "START" and "STOP" buttons on the membrane keypad.

Operating mode 2

2. Remote control via 2 external pushbuttons

The TURBOVAC starts if "START" (pin 1) is connected to pin 2 for a minimum of 3 seconds using an NO contact. The TURBOVAC stops if the connection between the two inputs, pin 2 and 3 "STOP" is disconnected using an NC contact.

Operating mode 3**3. Remote control via an external switch**

Connect pins 1 and 2 (jumper).

The TURBOVAC starts if "STOP2" (pin 3) is connected to the jumper, pin 1-2. The TURBOVAC stops if this connection is interrupted.

Operating mode 4**4. Automatic start when the power is switched-on**

Connect the three pins 1, 2 and 3 with one another. TURBOVAC starts automatically when the supply voltage is connected.

TURBOTRONIK can also be controlled via relays, optocouplers or open-collector circuits.

2.5 Operator control**Starting TURBOVAC**

Switch-on TURBOTRONIK, the "POWER" LED must light-up.

Depress the "START" button, or start TURBOVAC via remote control, refer to Section 2.4.

The pump runs-up. The "ACCEL" LED (acceleration) lights-up.

The "NORMAL" LED lights-up and the "ACCEL" LED goes dark when approximately 90% of the rated speed is reached.

**Switching-off
TURBOVAC**

Depress the "STOP" button, or shutdown TURBOVAC via remote control, refer to Section 2.4.

Only the "POWER" LED is lit.

After a fault has been removed, also depress the "STOP" button, or shutdown TURBOVAC via remote control and then restart it.



The equipment may only be connected-up by a suitably trained electrician or under his supervision in accordance with the valid IEC (international), EN (European) and/or domestic guidelines.

Caution

The plug connector strip of TURBOTRONIK NT12 is not shockproof. Thus, the equipment must be installed in a housing which is shockproof. The TURBOTRONIK NT 12 has components and parts at hazardous voltage levels. Before carrying out any work with the equipment open, it must be isolated from the line supply and locked-out against accidental re-closure.

3.1 Equipment configuration

3.1.1 Supply voltage range

TURBOTRONIK NT 12 can be operated with two supply voltages; between 200-240 V or between 100-120 V. It is set in the factory for a specific supply voltage range which can be identified by the Order No., refer to Catalog No. under Section 1.4.

Caution

TURBOTRONIK will be damaged if it is connected to the wrong line supply voltage.

Refer to Section 5.1 when changing-over the supply voltage range.

3.1.2 Relay assignment

TURBOTRONIK NT 12 has 2 relays; the "NORMAL" (K1) and "FAIL"/ fault (K2) signals are available at its outputs when the equipment is shipped.

These relay functions can be changed using a jumper. Further, both relays can be changed over from an NO contact to an NC contact. Also refer to Section 5

Status when shipped

Changing-over the relay assignment

K2: Controlling the pre-vacuum pump

Relay **K2** can be used to control the "pre-vacuum pump". In this case, it is active after the start, and inactive after the TURBOVAC has been shutdown.

3.1.3 Resonance monitoring function

TURBOTRONIK NT 12 has a resonance monitoring function for the TURBOVAC 50D. The resonance monitoring function shuts down the drive and displays a fault if the pump remains in the speed range between 45,000 and 55,000 RPM for longer than approximately 1 minute. When shipped, the resonance monitoring function is active, and can be disabled when operating the TURBOVAC 50; also refer to Section 5.6.

**Tip**

We recommend that if you change the relay assignment or if the resonance monitoring function is disabled, then this should either be noted on the equipment itself, or documented in the associated Instruction Manual.

Caution

If TURBOVAC 50D is used without the resonance monitoring function, this can lead to bearing damage.

Further, the assignment of the control inputs can be changed so that the motor frequency of the TURBOVAC can be measured, also refer to Section 5.8.

3.2 Installing TURBOTRONIK

Mount the TURBOTRONIK using M3 bolts. The cover has 4 holes for this purpose, refer to *Fig. 4, Dimension drawings*

Ensure that the equipment is adequately ventilated! In operation, it is not permissible that the ambient temperature exceeds 40°C.

3.3 Electrical connection

The supply, the TURBOVAC, relays and control inputs are connected via the plug connector strip at the rear of the unit; refer to Fig. 6 for the pin assignment.

**Caution**

The line supply voltage can be present at various locations of the connector strip. Only touch the connector connections when the TURBOTRONIK is isolated from the line supply.

A mating connector to the plug connector strip is supplied with the connecting cable to TURBOVAC. Connect the connecting cable in accordance with the attached drawing "installation information, pump cable".

If you assemble your own connecting cable, observe that it can be a maximum of 100 m long. Only use double screened cables with the appropriate insulation. If you require any further information please inquire.

**Protective conductor connection****Caution**

High discharge currents! If the connecting cable between the TURBOVAC and TURBOTRONIK is longer than 10 m, protective ground must be connected to both units.

3.3.1 Connecting the relay contacts

The "NORMAL" and "ACCEL" (acceleration) operating statuses can be interrogated at pins 8 and 10.

- Pins 8-10 closed: "NORMAL"
- Pins 8-10 open: "ACCEL", standstill or fault

When a fault occurs, relay 2 pulls-in and pins 12 and 14 are jumpered (NO contact).

► The relays can be assigned differently, also refer to Section 5.4.



The supply voltage or functional extra low voltage can be connected to the relay contacts. Observe the appropriate safety regulations.

Messerkontaktleiste X11

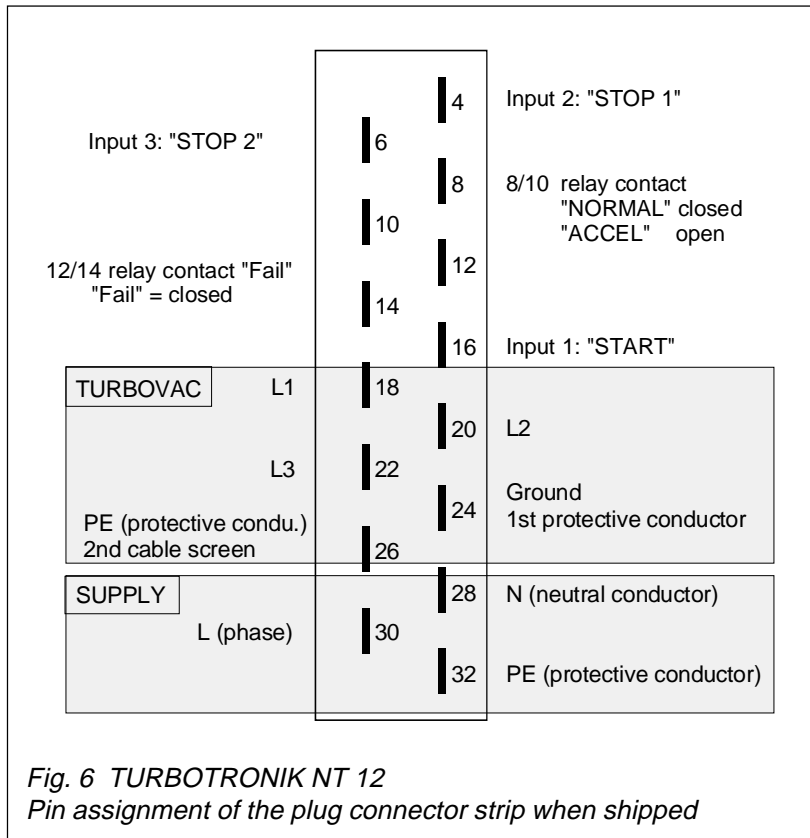

3.4 Operating modes/remote control

When TURBOTRONIK NT 12 is shipped, 3 operating modes are possible by appropriately connecting inputs, pins 4, 6 and 16 of the plug connector strip.

► The equipment configuration can also be changed-over to other functions using plug-in jumpers and other jumpers; also refer to Section 5.

Refer to Section 5.9 for circuit examples for remote control.

Operating modet 1

1. Remote control via 2 external pushbuttons

TURBOVAC starts if "START" (pin 16) is connected for at least 3 seconds with pin 4 via an NO pushbutton. TURBOVAC stops if the connection to the "STOP" inputs (pins 4 and 6) is interrupted using an NC contact.

Operating mode 2**2. Remote control via an external switch**

Establish a connection between pins 4 and 16.

TURBOVAC starts if "STOP2" (pin 6) is connected to pin 4 via a switch. TURBOVAC stops if the connection is re-interrupted.

Operating mode 3**3. Automatic start when the power is switched-on**

Connect all of the three pins (4, 6, 16) with one another. TURBOVAC starts automatically when the supply voltage is connected.

TURBOTRONIK can also be controlled via relays, optocouplers or open-collector circuits.

3.5 Operator control**Starting TURBOVAC**

Switch-on the TURBOTRONIK power supply, the "POWER" LED must light-up.

Start TURBOVAC via remote control, refer to Section 3.4.

TURBOVAC accelerates. The "ACCEL" (acceleration) LED lights-up.

The "NORMAL" LED lights-up and the "ACCEL" LED goes dark when approximately 90% of the rated speed is reached.

**Switching-off
TURBOVAC**

Switch-off TURBOVAC via the remote control; refer to Section 3.4.

Only the "POWER" LED is lit.

After a fault has been removed, also shutdown the TURBOVAC via the remote control and then restart it.



The equipment may only be connected-up by a suitably trained electrician or under his supervision in accordance with the valid IEC (international), EN (European) and/or domestic guidelines.

Caution

The plug connector strip of TURBOTRONIK NT13 is not shockproof. Thus, the equipment must be installed in a housing which is shockproof. The TURBOTRONIK NT13 has components and parts at hazardous voltages. Before carrying out any work with the equipment open, it must be isolated from the line supply and locked-out against accidental re-closure.

4.1 Equipment configuration

4.1.1 Supply voltage range

TURBOTRONIK NT 13 can be operated with two supply voltages; between 180-260 V or between 90-140 V.

It is set in the factory for a specific supply voltage range which can be identified from the Order No., refer to Catalog No. under Section 1.4.



Caution

TURBOTRONIK will be damaged if it is connected to the wrong line supply voltage.

Refer to Section 5.1 when changing-over the supply voltage range.

4.1.2 Relay assignment

TURBOTRONIK NT13 has 2 relays; Relay **K 1** is used as pressure trigger. It is switched, if a specified DC link current in the TURBOTRONIK is fallen below. This DC link current corresponds to a specific pressure under defined conditions.

When shipped, relay **K 2** is not used. When it is connected, the supply voltage outputs at pins 12 and 14 are no longer available.

The relays, when required, can be assigned, so that K1 indicates the "NORMAL" operating status, and relay K2 can be used to indicate faults or to control the pre-vacuum pump. Further, it is possible to changeover from NC contact to NO contact. Also refer to Section 5.

4.1.3 Resonance monitoring function

TURBOTRONIK NT 13 has a resonance monitoring function for the TURBOVAC 50D. The resonance monitoring function shuts down the drive and displays a fault if the pump remains in the speed range between 45,000 and 55,000 RPM for longer than approximately 1 minute.

When shipped, the resonance monitoring function is active, and can be disabled when operating the TURBOVAC 50; also refer to Section 5.6.

Status when shippel

Changing-over the relay assignment

Tip

We recommend that if you change the relay assignment or if the resonance monitoring function is disabled, then this should either be noted on the equipment itself, or documented in the associated Instruction Manual.



Rack mounting

Caution

If TURBOVAC 50D is used without the resonance monitoring function, this can lead to bearing damage.

4.2 Installing TURBOTRONIK

TURBOTRONIK NT13 is designed for mounting in 19" racks. Four holes are provided in the front panel for mounting.

Ensure that the equipment is adequately ventilated and, in operation, it is not permissible that the ambient temperature exceeds 40°C.

4.3 Electrical connection

The supply, the TURBOVAC, relays and control inputs are connected via the plug connector strip at the rear of the unit; refer to Fig. 7 for the pin assignment.



Caution

The line supply voltage can be present at various locations on the connector strip. Only touch the connector connections when the TURBOTRONIK is isolated from the line supply.

A mating connector to the plug connector strip is supplied with the connecting cable to TURBOVAC. Connect-up the connecting cable in accordance with the attached drawing "installation information, pump cable".

If you assemble your own connecting cable, observe that it can be a maximum of 100 m long. Only use double screened cables with the appropriate insulation. If you require any further information please inquire.



Protective conductor connection

Caution

High discharge currents! If the connecting cable between the TURBOVAC and TURBOTRONIK is longer than 10 m, protective ground must be connected to both units.

4.3.1 Connecting the relay contacts (also refer to Fig. 8)

A pressure trigger can be interrogated at pins 8 and 10

- Pins 8-10 closed: The DC link current in the TURBOTRONIK is lower than a specified limit value
- Pins 8-10 open: The DC link current in the TURBOTRONIK is greater than a specified limit value.

The limit value setting is very dependent on the particular application. When required, please contact us.

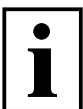

The supply voltage or functional extra low voltage can be connected to the relay contacts. Observe the appropriate safety regulations.

**Plug connector strip X11
NT13**

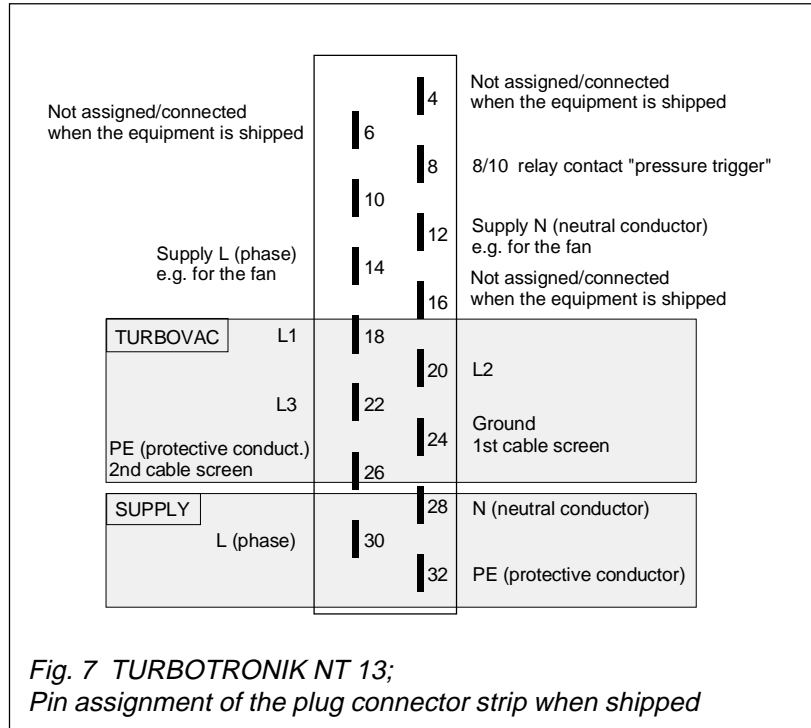

4.3.2 Connecting the test sockets

A voltage is available at the front panel test sockets, which is proportional to the DC link current in the TURBOTRONIK (1 mV = 1 mA). For specific operating statuses, this current can be assigned a particular inlet pressure; *also refer to Fig. 8.*

The relationship between the pressure and current depends on the particular application. Please contact us if you have any questions.

Voltage at the test sockets

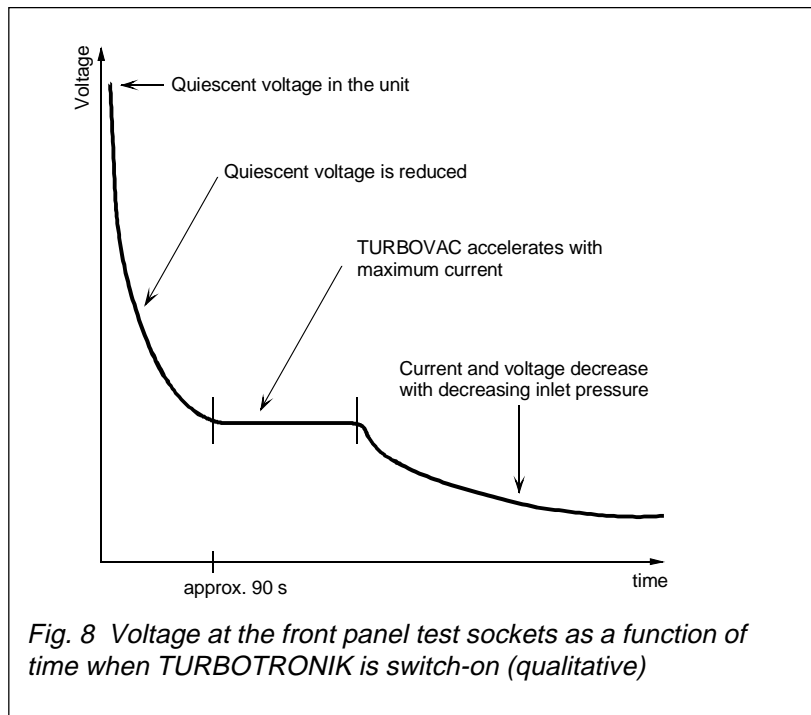

**Caution**

The measuring voltage is at line supply potential. Use insulated cables to connect-up a measuring unit so that it is not possible to come into contact with this voltage.

Changing the operating mode**4.4 Operating modes/remote control**

When shipped, the only mode which can be used with the TURBOTRONIK NT 13 is **“automatic start after the supply is switched-on”**.

TURBOTRONIK NT 13 can also be changed-over to remote control, as is described in Section 3.4 for TURBOTRONIK NT 12. Also refer to Section 5.

Starting TURBOVAC**4.5 Operator control**

Switch-on the power for the TURBOTRONIK, the **“POWER”** LED must light-up. TURBOVAC simultaneously starts.

The **“ACCEL”** (acceleration) LED lights-up.

The **“NORMAL”** LED lights-up and the **“ACCEL”** LED goes dark when approximately 90% of the rated speed is reached.

The pressure trigger relay (pins 8 and 10) closes when the DC link current in the TURBOTRONIK falls below the specified limit value.

Switching-off TURBOVAC

Shutdown TURBOVAC and TURBOTRONIK by switching-off the supply voltage.

After a fault has been removed, also shutdown TURBOVAC and TURBOTRONIK, and then switch-on again.

5.1 Selecting the supply voltage range

TURBOTRONIK NT10 and NT13

The supply voltage selector switch (9/3) is located inside the unit close to the front panel.

- Remove the two screws (9/1) on the righthand and lefthand sides of the unit, and carefully remove the front panel by swinging it out towards the lefthand side.
- Changeover the supply voltage selector switch (9/3). Re-install the front panel. When changing-over the supply voltage range, the fuse does not have to be changed

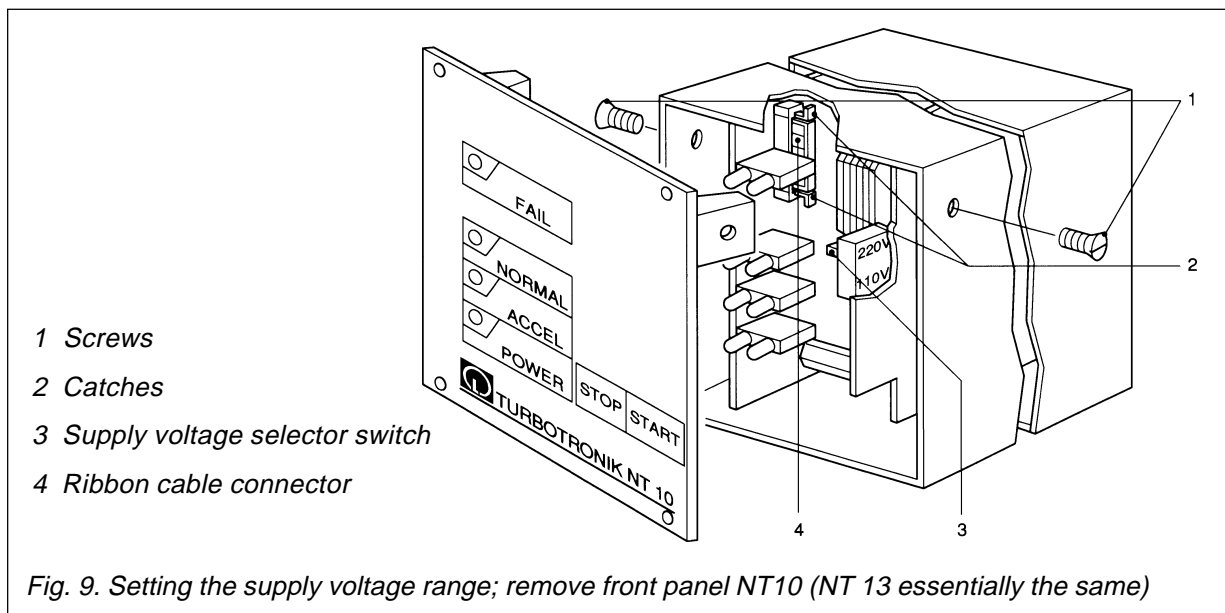

TURBOTRONIK NT12

The supply voltage selector switch of the TURBOTRONIK NT12 is accessible from the front through an air ventilation slot. It can be changed-over from the outside using a small screwdriver; also refer to the labelling on the housing.

When changing-over the supply voltage range, the fuse does not have to be changed.

Setting the supply voltage range for NT12

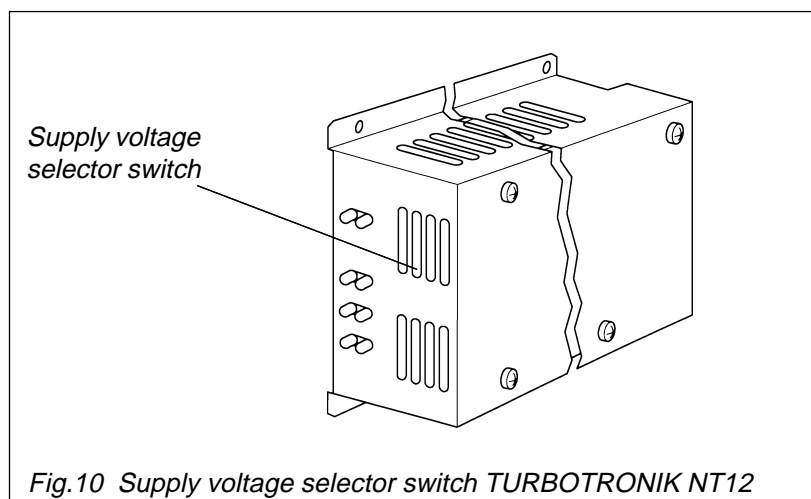



5.2 Withdrawing the PC boards

The PC boards must be removed from the housing so that the jumpers and wire jumpers are accessible to change the equipment configuration. Refer to Fig. 11 where the two unfolded PC boards are illustrated

5.2.1 NT10

- Remove the two screws (9/1) located on the righthand and lefthand sides of the unit and then carefully remove the front panel by swinging it out to the left.
- Press the catches (9/2) together and withdraw the inner part of the connector (9/4) several millimeters.
- Remove the ribbon cable from the connector.
- Unscrew the rear panel, and withdraw the PC boards towards the rear out of the housing, unscrew and fold-out
Refer to Sections 5.4 to 5.7 when changing the unit configuration
- Place the two PC boards over one another again, screw together and insert.
- Re-insert the ribbon cable
- Re-install the front- and rear panels.

5.2.2 NT12

- Remove the four screws on the cover, carefully withdraw the cover and remove the grounding cable.
- Remove the screws holding the PC boards together and fold-out.
Refer to Sections 5.4 to 5.7 when changing-over the unit configuration
- Place the PC boards on top of one another again, screw together, re-insert the grounding cable and re-install the cover

5.2.3 NT13

- Remove the two screws (9/1) at the righthand and lefthand sides of the unit and then remove the front panel.
- Remove the connecting cable to the test sockets in the front panel
- Unscrew the rear panel and remove the PC boards towards the back out of the housing, remove the screws holding them together and lay out.
Refer to Sections 5.4 to 5.7 when changing-over the unit configuration
- Place the PC boards one on top of the other again together again, screw and re-install
- Connect-up the test sockets again in the front panel ensuring that the polarity is correct.
- Re-install the front- and rear panels.

Tip

We recommend that if you change the relay assignment of if the resonance monitoring function is disabled, then this should either be noted on the equipment itself, or documented in the associated Instruction Manual.

5.3 Locations of the plug-in and jumpers

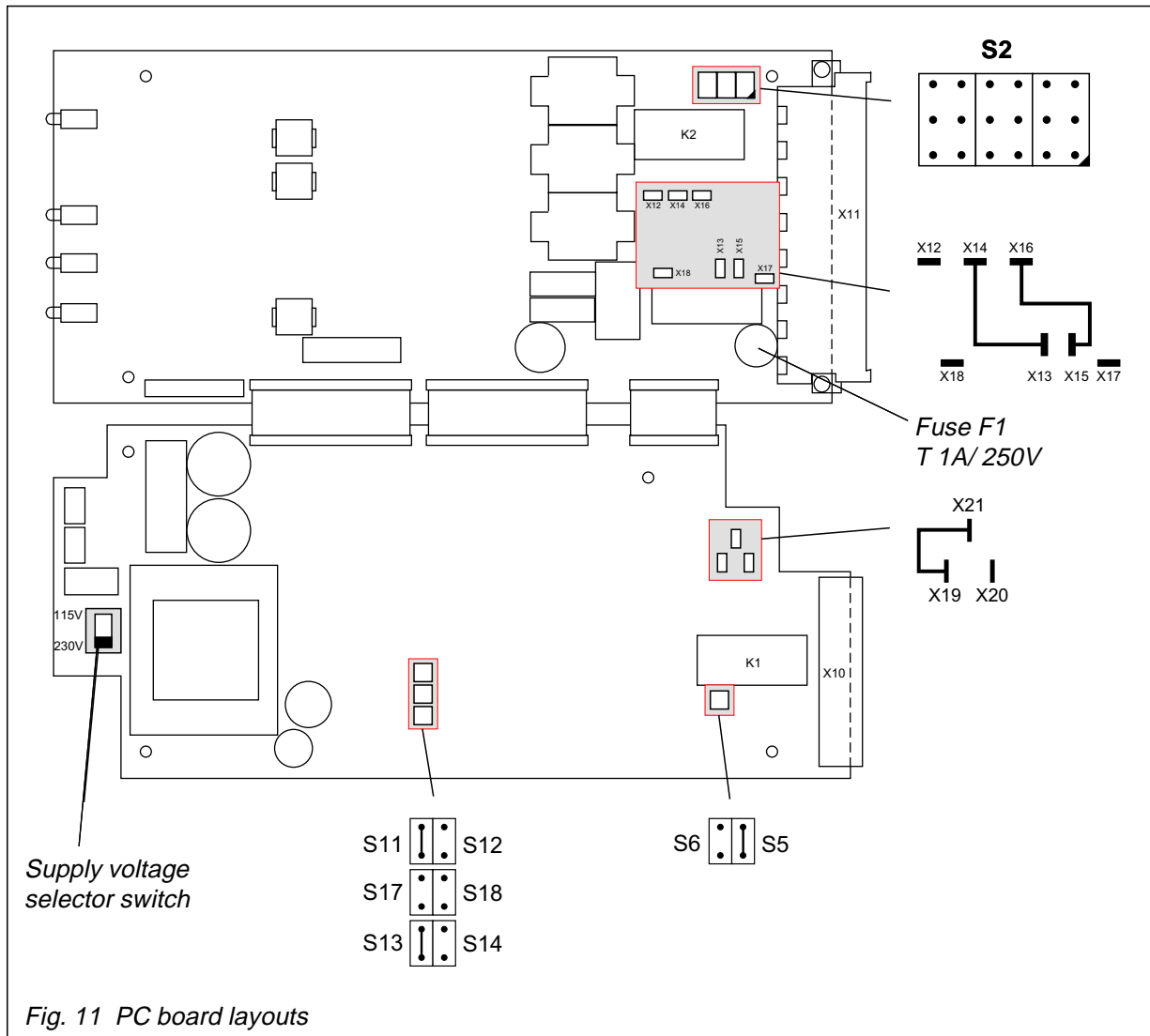

5.4 Relay statuses

Relay function	Operating status				
	Supply ON	ACCEL.	NORMAL	FAIL	STOP
Relay K1					
Normal	Off	Off	On	Off	Off
Pressure trigger	Off	Off	On *)	Off	Off
Relay K2					
Fail (fault)	Off	Off	Off	On	Off
Control, pre-vacuum pump	Off	On	On	On	Off

*) $I_{DC\ link} (DC\ link\ current) < I_{limit}$ (current limit) specified by the pressure trigger potentiometer

Off = not active; On = active

5.5 Setting the configuration of relay K1

„NORMAL“ function

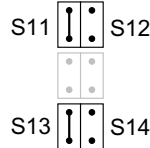

Fig. 12

The relay is switched when the “NORMAL” operating status is reached.

► Status when shipped NT 10, NT 12

„Pressure trigger“ function, version 1

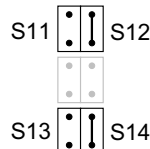

Fig. 13

The relay is switched if the DC link current in the TURBOTRONIK, specified by the pressure trigger potentiometer, is fallen below. The “NORMAL” LED is simultaneously lit.

„Pressure trigger“ function, version 2

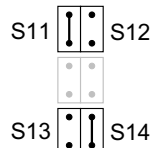

Fig. 14

The relay is switched if the DC link current in the TURBOTRONIK, specified by the pressure trigger potentiometer, is fallen below. The “NORMAL” LED is lit when the normal operating mode is reached.

► Status when shipped NT 13

Contact assignment K1 when shipped

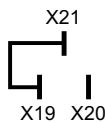

Fig. 15

NO contact for NT 12 and NT 13 (normally open)

► Status when shipped NT 13

Changing-over the contact assignment of K1

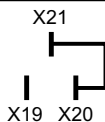

Fig. 16

NC contact for NT 12 and NT 13 (normally closed)

5.6 Setting the configuration of relay K2

„FAIL“ function

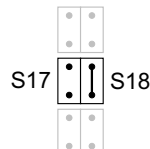

Fig. 17

The relay has the “FAIL” function (fault). The relay is active when a fault condition develops

► Status when shipped NT10, NT12

„Control, pre-vacuum pump“ function

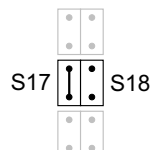
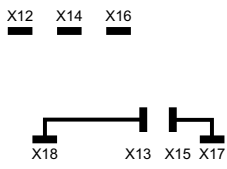

Fig. 18

The pre-vacuum pump is powered-up via the relay at the same time as the TURBOVAC is started with “START”, and is powered-down with “STOP” (also refer to Section 5.4, relay statuses).

K2 not operational



Relay K2 is disabled (not operational)!
For NT 12 and NT13: Supply N (neutral contactor) is connected to X11.12
 Supply L (phase) is connected X11.14
Bei NT 10:Supply N (neutral contactor) is connected to X10.9
 Supply L (phase) is connected X10.10
 ► **Status when shipped NT 13**

Fig. 19

Changing-over the contact assignment of K2

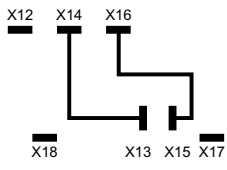

NO contact for **NT 10, NT 12 and NT13**
 (normaly open)
 ► **Status when shipped NT 10, NT 12**

Fig. 20

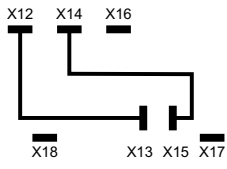

NC contact for **NT 10, NT 12 and NT13**
 (normaly closed)

Fig. 21

5.7 Setting the resonance monitoring funct.

Resonance monitoring function ON

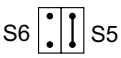

Resonance monitoring is switched-on for operation of TURBOVAC 50D
 ► **Status when shipped NT 10, NT 12, NT 13**

OFF

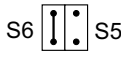

Resonance monitoring is switched-off for operation of the TURBOVAC 50

Fig. 22

5.8 Jumper field S2

START / STOP for NT 10

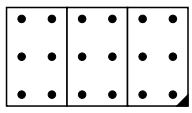

Pins 1, 2 and 3 of the Phönix connector X10 are used as control inputs to power the TURBOVAC on and off.
 ► **Status when shipped NT 10**

Fig. 23

START / STOP for NT 12 and NT 13

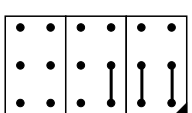

Pins 4, 6 and 16 of the plug connector strip X11 are used for the NT12 as control inputs to power the TURBOVAC on and off. NT13 can also be changed-over to this particular configuration.
 ► **Status when shipped NT 12**

Fig. 24

Automatic acceleration

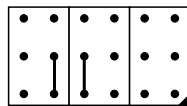

Fig. 25

The TURBOVAC automatically starts-up when the supply voltage is connected. This configuration can be selected for all three models.

► **Status when shipped NT 13**

Measuring the motor frequency NT12 and NT13

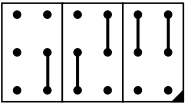

Fig. 26

Only possible for NT 12 and NT 13!

The motor frequency can be measured at pins 4, 6 and 16 of the plug connector strip; also refer to the circuit example in the following Section 5.8.

In this case, TURBOVAC automatically starts when the supply voltage is switched-on.

5.9 Measuring the motor frequency

The jumper field S2 must be inserted as shown in Fig. 26 to measure the motor frequency! Refer to the previous diagram!

The motor frequency is measured between pin 16 (0 V) and pin 6 (Q1). The frequency signal is present for approximately 0.1 seconds in each second. A gating signal is simultaneously output between 4 (Q5) and pin 16. This can be used to trigger a frequency count.

Diagram, measuring the motor frequency

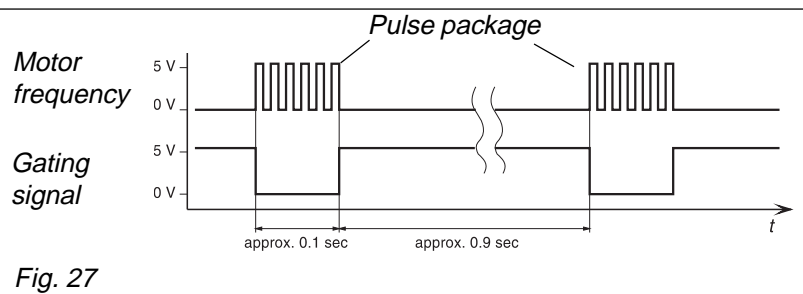

Fig. 27

Circuit example, measuring the motor frequency

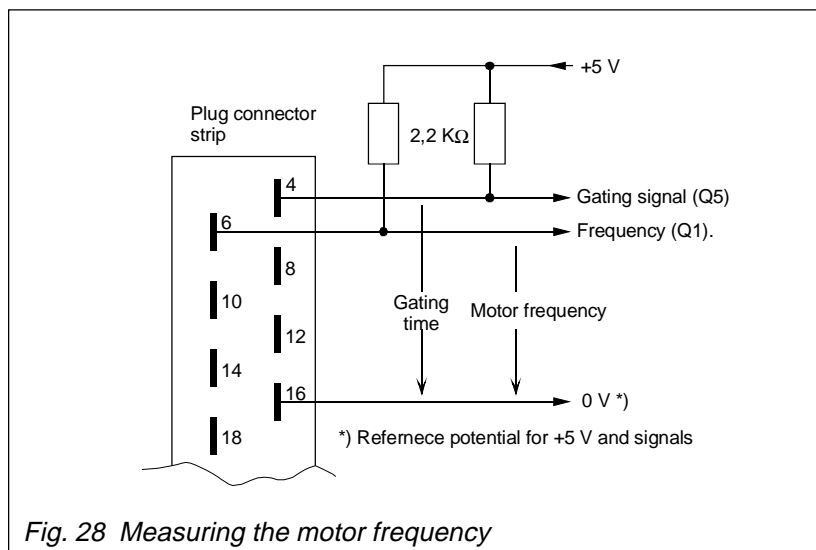

Fig. 28 Measuring the motor frequency

5.10 Connecting examples for remote control

Standard jumper NT 10, keypad operation

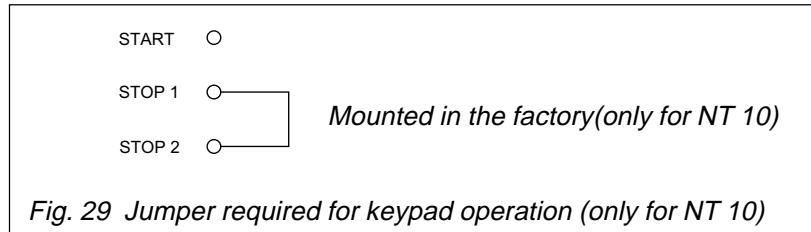

Fig. 29 Jumper required for keypad operation (only for NT 10)

Automatic start

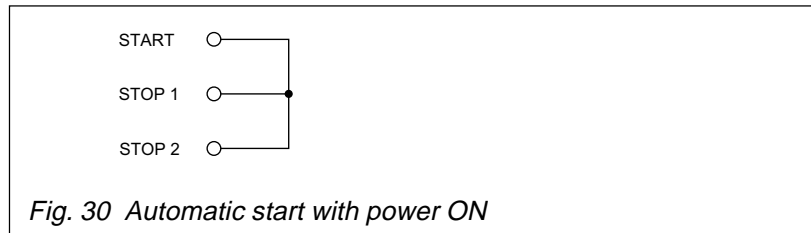

Fig. 30 Automatic start with power ON

Remote control with switch

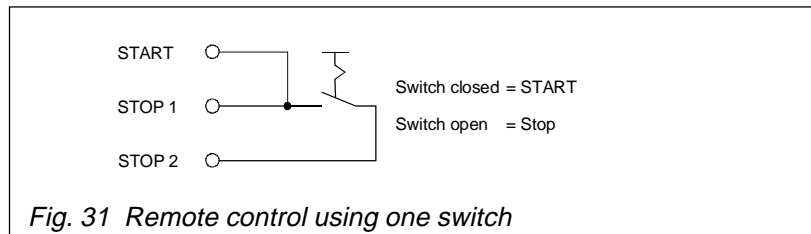

Fig. 31 Remote control using one switch

Remote control with 2 pushbuttons

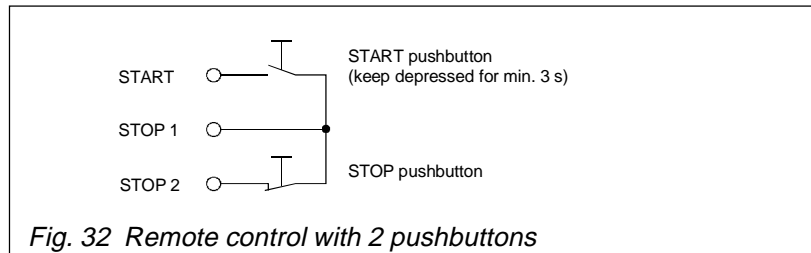

Fig. 32 Remote control with 2 pushbuttons

Remote control with optocouplers

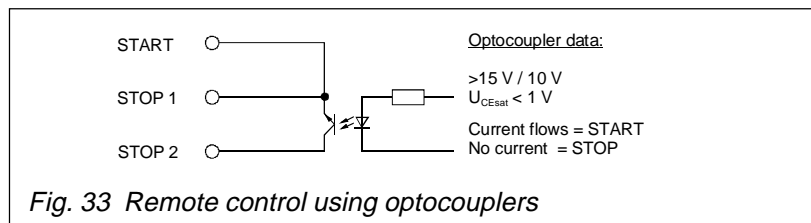

Fig. 33 Remote control using optocouplers

Remote control with open collector

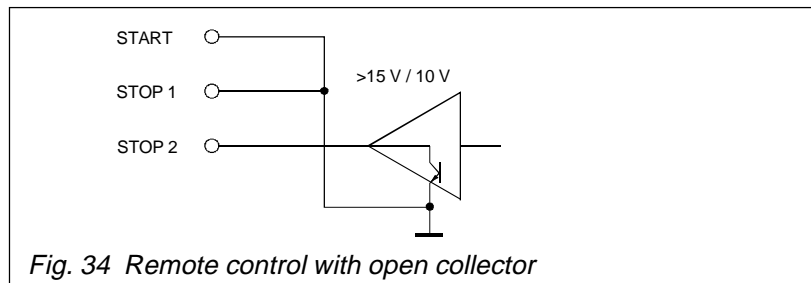

Fig. 34 Remote control with open collector

Assignment, function-terminal

- START = X10, PIN 1 (NT 10)
X11, Pin 16 (NT 12, NT 13)
- STOP 1 = X10, Pin 2 (NT 10)
X11, Pin 4 (NT 12, NT 13)
- STOP 2 = X10, Pin 3 (NT 10)
X11, Pin 6 (NT 12, NT 13)

Fault

• Possible cause / ► Counter-measure

„Power“ LED not lit

- TURBOTRONIK is not connected to the supply
- Supply switch not switched-on (only NT 10).
- Fuse blown
- Establish the connection to the supply
- Switch-on the power switch at the rear panel of the TURBOTRONIK NT 10
- Check the fuse (refer to Fig. 11) and if required, replace. Open-up the TURBOTRONIK as explained under Sections 5.1 and 5.2.

“ACCEL” LED, “NORMAL” LED do not light up even after an adequate acceleration time

- Leak in the vacuum system so that the rated speed is not reached.
- Gas has leaked into the vacuum system, so that when the final speed is reached, it decreases as a result of the excessive gas friction
- Seal the vacuum system

Note

Gas leaks cause the speed to be reduced. If the speed falls below approximately 40% of the rated speed, TURBOTRONIK switches again to “ACCEL”. TURBOTRONIK automatically runs-up again if the leak is not excessive.

“FAIL” LED is lit (FAIL relay is active, when the appropriate circuitry is available), and the TURBOVAC speed drops.

- The TURBOVAC motor winding has exceeded the permissible limit temperature, e.g. due to an inadmissibly high ambient temperature, or inadequate cooling.
 - The resonance monitoring has shutdown the drive, because the pump speed was within the speed range between 45,000 and 55,000 RPM for longer than one minute.
 - Let the TURBOVAC cool down. Improve the cooling!
- Reset the fault by actuating “STOP”. Power-down the TURBOVAC using the appropriate pushbutton or remote control and then restart it.
- Change the operating conditions so that the pump can rotate above 55,000 RPM. For TURBOVAC 50, the resonance monitoring function can be disabled (refer to Section 5.5).

Fault

"FAIL" LED is lit (the FAIL relay is active if the appropriate circuitry is available) and TURBOVAC does not run-up

• Possible cause / ► Counter-measure

- The connecting cable to the TURBOVAC or connector is defective or incorrectly connected.
- The TURBOVAC motor winding is inadmissibly hot.
- Check the connecting cable and connector and if required, replace. Reset the fault by depressing "STOP". Power-off the TURBOVAC either using the appropriate pushbutton or remote control and then restart it.
- Let the TURBOVAC cool down. Reset the fault by depressing "STOP". Power-down using the appropriate pushbutton or remote control and then re-start the TURBOVAC

The pump rotates normally, "NORMAL" LED is lit, but an adequate final pressure is not achieved

- Leak in the vacuum system.
- Pump rotates in the incorrect direction
- Remove the leak!
- Check the three motor connection phases; if applicable, interchange 2 phases

EC DECLARATION OF MANUFACTURE

EC declaration of manufacture

(in accordance with Art. 4 paragraph 2 of EC directive 89/329/EEC)

Document No.: **MSR0196 / NT10, NT12, NT13**
Manufacturer: **REFU elektronik GmbH**
Product Identification: **Typ: NT10, NT12, NT13**
Catalog No.: **859 00**
859 01
859 04
859 05
859 06
859 07

The product indicated solely for fitting in another machine.
Commissioning is prohibited until the conformity of the end
product with EC directive 89/392/EEC has been established.

Standards applied: **EN 60204-1 (DIN VDE 0113 part 1)**
EN 61010-1 (DIN VDE 0411 part 1)

1996-01-02
REFU elektronik GmbH



.....
H. Baumann
President

The safety notes given in the product documentation must be observed.

EC DECLARATION OF CONFORMITY

EC declaration of conformity

Document No.: **NSR0196 / NT10, NT12, NT13**
Manufacturer: **REFU elektronik GmbH**
Product Identification: **Typ: NT10, NT12, NT13**
Catalog No.: **859 00**
859 01
859 04
859 05
859 06
859 07

Herewith, we declare that this product, as a result of its design and type of construction, and the version marketed by us, correspond to the basic health and safety regulations specified in the EEC Directives.

This declaration is no longer valid if the product is modified without us being in full agreement.

The product conforms to the EEC Low-Voltage Directive (73/23/EEC).

Standards applied: **EN 61010-1 (DIN VDE 411 part 1)**
Edition 1994-03

Display the CE-mark: **1997**

1996-01-02

REFU elektronik GmbH

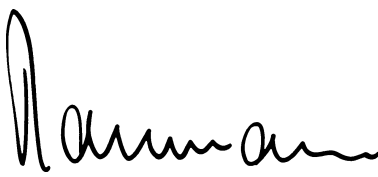

H. Baumann
President

The safety notes given in the product documentation must be observed.

FACTORY CERTIFICATE

Factory certificate

Document No.: **EMV0196 / NT10, NT12, NT13**
Manufactureur: **REFU elektronik GmbH**
Product Identification: **Typ: NT10, NT12, NT13**
Catalog No.: **859 00**
859 01
859 04
859 05
859 06
859 07

The named product, when put to its intended use, satisfies the requirements of Directive 89/336/EEC concerning electromagnetic compatibility.

The applicable measurements were made taking into account the following standards:

EN 500 82-2
EN 55011 (DIN VDE0875 Teil 1)
EN 61000-3-2
EN 61000-3-3

Note

Attention must be paid to the information provided on provided on proper installation with respect to elektromagnetic compatibility and to other pertinent notes in the documentation supplied with the product, as well as to the relevant information concerning electrical connection.

1996-01-02

REFU elektronik GmbH



H. Baumann
President

LEYBOLD VAKUUM GMBH