

Exhaust Filters with Lubricant Return ARS 16-25 and ARS 40-65



ARS 40-65

This combination of an exhaust filter with a float-controlled valve considerably extends the maintenance intervals of the TRIVAC BCS.

The ARS is part of the TRIVAC SYSTEM.

Advantages to the User

- Lubricant return with the aid of a float-controlled valve back into the intake port
- The intake port may be easily exchanged (either vertical or horizontal orientation)
- No operating costs caused by lost lubricant
- Hardly any oil consumption
- Visual indication of the differential pressure
- Standard filter element
- All aluminium parts are surface protected
- Built-in over-pressure relief valve
- Resists solvents
- All seals made of FPM
- May also be used on the TRIVAC B

Typical Application

- Filtering the exhaust air of entrained lubricant particles

Technical Information

An exhaust line must be connected in case of hazardous exhaust gases.

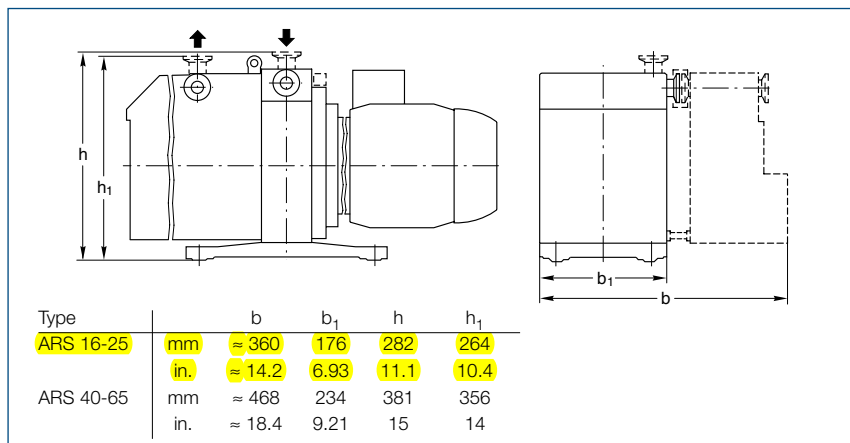

Dimensional drawing for the ARS mounted on a TRIVAC BCS

The ARS is connected to the exhaust port of the TRIVAC BCS, the return line is connected at the intermediate flange under the intake port.

The ARS is cleaned in the factory to such an extent, that it may be operated either with mineral oil (e.g. N 62 or HE-200) or perfluoropolyther (PFPE e.g. NC 1/14 or HE-1600).

Supplied Equipment

Intermediate flange, connecting lines with hollow screws, required gaskets as well as mounting screws for the intake flange.

Wrapped in foil for shipping.

Technical Data		ARS 16-25	ARS 40-65
Connection to pump	TRIVAC	D 16/25 B; D 16/25 B/BCS (-PFPE)	D 40/65 B/BCS (-PFPE)
Connection flanges	DN	25 KF	40 KF
Amount of oil required for opening the float-controlled valve			
	N 62/HE-200	cm³ (qt)	510 (0.54)
	PFPE	cm³ (qt)	340 (0.36)
Remaining amount of oil			
	N 62/HE-200	cm³ (qt)	430 (0.45)
	PFPE	cm³ (qt)	300 (0.31)
Weight with intermediate flange, tubing and filter, without lubricant		kg (lbs)	4.7 (10.4)
Weight with intermediate flange, tubing and filter, with lubricant		kg (lbs)	8.5 (16.7)
Ordering Information		ARS 16-25	ARS 40-65
Exhaust filter with lubricant return		Part No. 189 56	Part No. 189 57
Replacement filter element			
	FE 16-25	Part No. 189 72	-
	FE 40-65	-	Part No. 189 73