

# ***HS-2 Diffusion Pump***

Part No. 699901150

Rev. E

December 2005

[idealvac.com](http://idealvac.com)  
**Ideal**  
vacuum products  
(505)872-0037  
[idealvac.com](http://idealvac.com)

# HS-2 Diffusion Pump



*Santovac<sup>®</sup> 5 Diffusion Pump Fluid of SANTOVAC FLUIDS, INC.*

*Viton<sup>®</sup> is a registered trademark of E. I du Pont de Nemours and Company.*

# Warranty

Products manufactured by Seller are warranted against defects in materials and workmanship for twelve (12) months from date of shipment thereof to Customer, and Seller's liability under valid warranty claims is limited, at the option of Seller, to repair, replacement, or refund an equitable portion of the purchase price of the Product. Items expendable in normal use are not covered by this warranty. All warranty replacement or repair of parts shall be limited to equipment malfunctions which, in the sole opinion of Seller, are due or traceable to defects in original materials or workmanship. All obligations of Seller under this warranty shall cease in the event of abuse, accident, alteration, misuse, or neglect of the equipment. In-warranty repaired or replaced parts are warranted only for the remaining unexpired portion of the original warranty period applicable to the repaired or replaced parts. After expiration of the applicable warranty period, Customer shall be charged at the then current prices for parts, labor, and transportation.

When products are used with toxic chemicals, or in an atmosphere that is dangerous to the health of humans, or is environmentally unsafe, it will be the responsibility of the Customer to have the product cleaned by an independent agency skilled and approved in handling and cleaning contaminated materials before the product will be accepted by Varian, Inc. for repair and/or replacement.

Reasonable care must be used to avoid hazards. Seller expressly disclaims responsibility for loss or damage caused by use of its Products other than in accordance with proper operating procedures.

Except as stated herein, Seller makes no warranty, express or implied (either in fact or by operation of law), statutory or otherwise; and, except as stated herein, Seller shall have no liability under any warranty, express or implied (either in fact or by operation of law), statutory or otherwise. Statements made by any person, including representatives of Seller, which are inconsistent or in conflict with the terms of this warranty shall not be binding upon Seller unless reduced to writing and approved by an officer of Seller.

# Disclaimer

Operation and maintenance of this equipment involves serious risk. It is the responsibility of the user to maintain safe operating conditions at all times. Varian assumes no liability for personal injury or damage resulting from operation or service of the equipment.

Varian has no control over the use of this equipment and is not responsible for personal injury or damage resulting from its use. The safe use and disposal of hazardous or potentially hazardous materials of any kind is the sole responsibility of the user. Observe all WARNINGS and CAUTIONS to minimize the serious hazards involved.

It is the sole responsibility of the users of Varian equipment to comply with all local, state and federal safety requirements (laws and regulations) applicable to their system. Employ the services of an industrial hygienist and/or a qualified chemical safety engineer in order to ensure safe installation and use.

## HS-2 Diffusion Pump

---

### **Warranty Replacement and Adjustment**

All claims under warranty must be made promptly after occurrence of circumstances giving rise thereto, and must be received within the applicable warranty period by Seller or its authorized representative. Such claims should include the Product serial number, the date of shipment, and a full description of the circumstances giving rise to the claim. Before any Products are returned for repair and/or adjustment, written authorization from Seller or its authorized representative for the return and instructions as to how and where these Products should be returned must be obtained. Any Product returned to Seller for examination shall be prepaid via the means of transportation indicated as acceptable by Seller. Seller reserves the right to reject any warranty claim not promptly reported and any warranty claim on any item that has been altered or has been returned by non-acceptable means of transportation. When any Product is returned for examination and inspection, or for any other reason, Customer shall be responsible for all damage resulting from improper packing or handling, and for loss in transit, notwithstanding any defect or non-conformity in the Product. In all cases, Seller has the sole responsibility for determining the cause and nature of failure, and Seller's determination with regard thereto shall be final.

If it is found that Seller's Product has been returned without cause and is still serviceable, Customer will be notified and the Product returned at its expense; in addition, a charge for testing and examination may be made on Products so returned.

3/1/00

# Contents

Documentation Conventions .....	xii
Diffusion Pump Hazards .....	xii
<b>Installation, Maintenance and Specifications .....</b>	<b>1-1</b>
Installation .....	1-1
Pump Fluid Installation .....	1-2
Maintenance .....	1-3
Changing Heater Element.....	1-3
HS-2 Diffusion Pump Specifications.....	1-3
Operating Specifications .....	1-5
PHYSICAL SPECIFICATIONS.....	1-6
Optional Components.....	1-7
Replaceable Parts.....	1-8

## HS-2 Diffusion Pump

---

*This page intentionally left blank.*

# Figures

1-1	Cold Cap Installation .....	1-2
1-2	HS-2 Speed Curve.....	1-3
1-3	HS-2 Cross Section .....	1-4
1-4	HS-2 Flange and Pump .....	1-5

## HS-2 Diffusion Pump

---

*This page intentionally left blank.*



## List of Tables

1	General Hazards.....	xiii
2	Explosive Conditions.....	xv
3	Pressurization Hazards.....	xvi
1-1	Operating Specifications.....	1-5
1-2	Physical Specifications.....	1-6
1-3	Optional Components.....	1-7
1-4	Replacement Parts .....	1-8
1-5	Cold Cap Replacement Parts.....	1-9

## HS-2 Diffusion Pump

---

*This page intentionally left blank.*

Declaration of Conformity  
Konformitätserklärung  
Déclaration de Conformité  
Declaración de Conformidad  
Verklaring de Overeenstemming  
Dichiarazione di Conformità



We  
Wir  
Nous  
Nosotros  
Wij  
Noi

Varian, Inc.  
Vacuum Technologies  
121 Hartwell Avenue  
Lexington, MA, 02421-3133 USA

declare under our sole responsibility that the product,  
erklären, in alleniniger Verantwortung, daß dieses Produkt,  
déclarons sous notre seule responsabilité que le produit,  
declaramos, bajo nuestra sola responsabilidad, que el producto,  
verklaren onder onze verantwoordelijkheid, dat het product,  
dichiariamo sotto nostra unica responsabilità, che il prodotto,

### HS-2 Diffusion Pump

to which this declaration relates is in conformity with the following standard(s) or other normative documents.  
auf das sich diese Erklärung bezieht, mit der/den flogenden Norm(en) oder Richtlinie(n) übereinstimmt.  
auquel se réfère cette déclaration est conforme à la (auz) norme(s) ou au(x) document(s) normatif(s).  
al que se refiere esta declaración es conforme a la(s) norma(s) u otro(s) documento(s) normativo(s).  
waamaar deze verklaring verwijst, aan de volende norm(en) of richtlijn(en) beantwoordt.  
a cui se riferisce questa dichiarazione è conforme alla/e sequente/I norma/o documento/I normativo/i.

VMF-11	M-2	VHS-6	HS-16
AX-65	M-4	VHS-250	HS-20
AX-150	VHS-4	VHS-10	HS-32
HS-2	M-6	VHS-400	NHS-35

### Low Voltage Directive

73/023/EEC

EN 61010-1..... "Safety requirements for electrical equipment for measurement, control and laboratory use", incorporating amendments, numbers 1 and 2.

Frederick C. Campbell  
Operations Manager  
Vacuum Technologies  
Varian, Inc.  
Lexington, Massachusetts, USA

February 2000



# Preface

## Documentation Conventions

This manual uses the following documentation conventions:

### **WARNING**



*Warnings indicate a particular procedure or practice, which if not followed correctly, could lead to serious injury.*

### **CAUTION**



*Cautions indicate a particular procedure or practice, which if not followed, could cause damage to the equipment.*

### **NOTE**



*Notes contain important information.*

Before operating or servicing equipment, read and thoroughly understand all operation/maintenance manuals provided by Vacuum Technologies. Be aware of the hazards associated with this equipment, know how to recognize potentially hazardous conditions, and how to avoid them. Read carefully and strictly observe all cautions and warnings. The consequences of unskilled, improper, or careless operation of the equipment can be serious.

In addition, consult local, state, and national agencies regarding specific requirements and regulations. Address any safety, operation, and/or maintenance questions to your nearest Vacuum Technologies office.

## Diffusion Pump Hazards

Designers of systems utilizing diffusion pumps must design out hazards wherever possible. For hazards that cannot be designed out, warnings, procedures, and instructions on proper use and servicing are provided. Please use guards, safety features, and interlocks as recommended.

Refer to Table 1 for a list of general hazards and recommended actions, Table 2 on page xv for a list of prohibited actions that can result in explosions, and Table 3 on page xvi for a list of pressurization hazards that can result in damage to equipment.

## HS-2 Diffusion Pump

The installation, operation, and servicing of diffusion pumps involves one or more of the hazards in 1, any one of which in the absence of safe operating practices and precautions, could potentially result in death or serious harm to personnel.

**Table 1 General Hazards**

Hazard	Suggested Corrective Action
Loss of utility: water and/or electricity	Provide sufficient backup water and power supply as necessary to effect a safe shutdown under worst case conditions
Overpressure in foreline	Provide an interlock to ensure that the power supply to the pump heater cannot be activated if the foreline pump is not running and/or the pressure in foreline is above 0.5 Torr (0.38 mbar)
Overtemperature	Fit temperature sensors and pump fluid level sensors with a feedback to an interlock on the heater power supply
Insufficient water flow through the main cooling coils	Use water flow sensor and feedback to interlock the heater power supply
Water trapped between inlet and outlet of Quick Cool coil, or liquid nitrogen trapped between inlet and outlet of liquid nitrogen trap	Provide vent or pressure relief valves for both Quick Cool coil and liquid nitrogen trap
Loss of electrical ground integrity	Incorporate ground fault interrupt circuit into heater power supply
Positive pressure in pumping system	Integrate pressure relief valve in vacuum system
High voltage	Prevent personnel contact with high voltages; design and attach warnings
Toxicity and Corrosivity	Vent toxic and/or corrosive gases to a safe location; ensure adequate dilution or scrubbing to safe levels; take all actions required to meet air quality standards
Explosion	Integrate pressure relief valves
	Do not use hydrocarbon-based pumping fluids

### Explosion

- ❑ Operation of the diffusion pump without continuous evacuation below 0.5 Torr (0.67 mbar), or without coolant and introducing a strong oxidizer (such as air) or explosive vapors or powders or materials which may react with pumping fluids in a hot pump (above 300 °F or 150 °C) can cause an explosion. Such an explosion can violently expel valves and other hardware, slam open doors that are not designed for appropriate pressure relief, or burst other components of the vacuum system. Serious injury or death may result from expelled parts, doors, shrapnel, and shock waves.
- ❑ *Three elements are required for explosion:* fuel, oxidizer, and an ignition. A combination of temperature and pressure can be a source of ignition. Most diffusion pump fluids are fuels. Hydrocarbon fluids are more prone to oxidize and explode than synthetic silicone-based fluid. The oxidizer can be air, which can be introduced by a leak, deliberately brought in via a process, or inadvertently admitted by operator error.  
Oxygen and other strong oxidizers are even more dangerous than air. Certain conditions of temperature and pressure can cause a combustible mixture to explode. The larger the diffusion pump, the greater the risk of explosion and the greater the risk of damage and injury. Never operate large diffusion pumps utilizing hydrocarbon oils without a complete safety analysis for the entire system and for the application.
- ❑ *Explosion and Fire from Acetone and Alcohol:* Diffusion pumps are typically cleaned with acetone and alcohol. When combined with air, oxygen, and other oxides, alcohol and most other solvents are very flammable and explosive. Never permit any trace of these cleaners to remain in or on the pump. Always remove all traces of alcohol and acetone and other cleaners with clean, dry, oil-free compressed air.

## HS-2 Diffusion Pump

Never operate a large diffusion pump under the conditions listed in Table 2. Any of these situations increases the probability of an explosion.

**Table 2 Explosive Conditions**

<b>Prohibited Action</b>	<b>Explosion-Causing Condition</b>
Do not run pump without cooling water	Overtemperature
Do not run pump with low level of pump fluid	Overtemperature
Do not run pump without proper backing or holding pump	Overpressure
Do not run pump when not evacuated below 0.5 Torr (0.66 mbar)	Overpressure
Do not admit air to, or rough through, a pump with hot boiler	Overpressure plus strong oxidizer
Do not open drain or fill plug while pump is under vacuum, especially when it is hot	Overpressure plus strong oxidizer
Do not contaminate pump with explosive vapors	Lower explosive threshold of gas mixtures
Do not remove, defeat, or override safety counter-measures such as pressure and thermal switches and valve sequencer interlocks	Overtemperature, overpressure, more combustible mixtures
Do not machine or weld any part of the pump without removing all fluid or solvent residue in pump	Source of ignition
Do not use unsuitable pumping fluid	Lower explosive threshold of gas mixture

## HS-2 Diffusion Pump

### Pressurization Hazards

Large vacuum pumps and their components are designed for vacuum service. They are not designed for pressurization, which could cause them to burst possibly expelling shrapnel at lethal velocities. Serious accidents have been caused by intentional pressurization of vacuum systems and their components.

- ❑ Never pressurize any part of a vacuum system for test or any other purpose.
- ❑ Always provide pressure relief when designing diffusion pumps into systems and ensure that pressure relief motion is limited to safe envelopes.
- ❑ Never permit the hazards in Table 3 to develop.

**Table 3 Pressurization Hazards**

Prohibited Action	Result
Do not block inlet or vent of liquid nitrogen trap and lines	LN <sub>2</sub> trap and/or lines burst
Do not close isolation valves at inlet and discharge of main water cooling coils when pump is heated	Water turns to steam and bursts coils
Do not pressurize the pump body (above 1 atm.)	Body of pump bursts
Do not make a hole through the vacuum wall	Loss of structural integrity of wall

- ❑ *Pressure Relief Devices:* Systems must be designed with pressure relief devices to provide safe pressure relief from internal explosions. Always recognize that safety devices can fail or malfunction. Provide redundant protection by installing devices having different failure modes, failure mechanisms, and failure causes. Be certain that exhaust duct materials are capable of withstanding the corrosiveness, temperature, and pressure of exhausted products.

### Dangerous Substances

- ❑ *Chemical Dangers of Acetone and Alcohol:* Diffusion pumps are typically cleaned with acetone or alcohol. Acetone, alcohol, and most other solvents are irritants, narcotics, and depressants, and/or carcinogenic. Their inhalation and ingestion may produce serious effects. Even absorption through the skin can result in moderate toxicity. Always ensure that cleaning operations are performed in large, well-ventilated rooms. Use of self-contained breathing apparatus may be necessary, depending upon the solvent type and vapor concentration in surrounding air.
- ❑ *Poisonous and Corrosive Compounds:* When pumping poisonous, reactive, and/or corrosive gas, vapors, or chemicals, proper operation and regeneration do not always ensure that all hazardous materials have been totally removed. If hazardous gas, vapors, chemicals, or combustible mixtures are pumped, sufficient quantities may exist during operation or remain after regeneration to cause severe injury or death.



## HS-2 Diffusion Pump

---

- ❑ *Pump Fluids:* Overheating the pump fluid, exposing it to air or reactive materials, or over-pressurizing it above the normal operating range, approximately  $1 \times 10^{-3}$  Torr ( $1.3 \times 10^{-3}$  mbar) decomposes the fluid and possibly makes it toxic. This is especially true of backstreamed mechanical pump fluids which are more volatile (unstable). Overheating of accidentally introduced or backstreamed mechanical pump fluids cannot be protected against by thermal switches which are set for diffusion pump fluid.
- ❑ *Process Gasses:* Process gasses are frequently toxic, flammable, corrosive, explosive, or otherwise reactive. Vacuum Technologies has no control over the types of gasses passing through the user's diffusion pump as these are entirely under the control of the process user and/or the hardware systems integrator. Since these gasses can cause serious injury or death, it is very important to plumb the exhaust of the pump to the facility's hazardous gas exhaust system which incorporates appropriate filters, scrubbers and similar components to ensure that the exhaust meets all air and water pollution control regulations.

### High Temperatures

- ❑ *Hot Surfaces:* Boiler temperatures reach 530 °F (275 °C) which can cause serious burns. Always ensure that surfaces have cooled to near room temperature before touching them.
- ❑ *Hot Cooling Water and Steam:* The water used to cool the pump can reach scalding temperatures. Touching or rupture of the cooling surface can cause serious burns. Water left inside Quick Cool coils from previous use turns to steam when the pump is reheated. This steam must be allowed to escape without contacting personnel. Whenever possible, design the water system with interlock valves so that power cannot be applied to the pump unless water is flowing in the main cooling coils (not Quick Cool coils).

### Cold Surfaces

Liquid nitrogen cooled traps are commonly used in diffusion pumps. Metal surfaces at liquid nitrogen temperature can cause severe frostbite. These surfaces remain cold in excess of 30 minutes after liquid nitrogen evaporation.

## HS-2 Diffusion Pump

---

### Cold Coolant

Liquid nitrogen, a cryogenic liquid, is used in traps. If it is splashed on body tissues or eyes, it can cause severe frostbite or blindness. The extremely low temperature of liquefied nitrogen can cause skin damage similar to high temperature burns. Contact with the cold gas evolving from the liquid can produce the same effect. Delicate tissues, such as the eye tissues, are most easily damaged by exposure to cold gas or liquid. To minimize the risk of hazardous contact of cold gaseous nitrogen with any part of the body, wear personal safety equipment recommended for use with cryogenic materials, including:

- ❑ Face shield
- ❑ Full-sleeved lab coat
- ❑ Clean, dry gloves which fit loosely so they can be thrown off quickly if frozen by contact with the gas.

### High Voltages

Diffusion pump heaters operate at voltages (up to 480 V) high enough to kill. Design systems to prevent personnel contact with high voltages. Securely attach prominent hazard warnings. Personnel should always break the primary circuit to the power supply when direct access to the heater or wiring is required.

### Large Equipment and Heavy Weights

The lifting and moving of large diffusion pumps requires power-assisted equipment and the use of trained moving and installation personnel to avoid dropping, slipping, and overturning the pump. Pumps weigh in excess of 180 lbs (81 kg) and are 3 to 6 feet in their largest dimension (1 to 2 meters). Their mishandling can cause severe injury. Check the weight of the equipment before lifting and assure that the power-assist device is adequate for the task. Do not stand under the equipment being lifted and moved.

### Asphyxiation

Death from suffocation can result if a large amount of liquid nitrogen is spilled in a small, poorly ventilated room or equipment. All diffusion pumps are typically cleaned with acetone or alcohol. Acetone, alcohol, and most other solvents are very volatile (unstable). During cleaning, the volatility of these cleaners may permit their gases to displace air and its life-supporting oxygen which could cause death or serious injury by asphyxiation. Always ensure that cleaning operations are performed in large, well-ventilated areas.

# Installation, Maintenance and Specifications

## Installation

Before unpacking and installing this pump, read the safety precautions and general installation, operation and maintenance instructions in the "Preface", as well as the following specific instructions and specifications which pertain to the HS-2 water cooled diffusion pump.

In order to avoid damage during shipment, our conduction cooled cold cap is packaged separately from the jet assembly. Accordingly, it is necessary to install the cold cap on the jet assembly prior to use.

Each cold cap assembly has been individually cleaned and is shipped in a polyethylene bag. Inspect the carton and its contents for transit damage. Damage in transit is the responsibility of the transportation company and must be reported to them. Protect all components from dirt before and during installation. Do not open the plastic containers until the diffusion pump is ready to receive the cold cap installation, after preparatory pump inspection.

Figure 1-1 shows the cold cap correctly mounted on the top jet. Refer to Figure 1-3 on page 1-4 and Figure 1-4 on page 1-5 during installation.

To install the cold cap:

1. Mount the teflon button (Item 3) on the jet cap.
2. Install the jet (Item 1) in the pump body.
3. Install the cold cap (Item 2) as shown in Figure 1-1, ensuring that it is resting firmly on the shoulder of the teflon button:
  - a. Attach the stand-off (Item 6) to the threaded portion of the tie rod (Item 3) of the jet assembly (Item 1). Secure the stand-off hand-tight only. *Do not use force.*
  - b. Insert the cold cap (Item 4) into the pump barrel by compression of the thermal contact spring against the pump wall.
  - c. Slide the cold cap into the pump barrel until the underside of the end of the copper cup rests against the stand-off (Item 6). The spacer bar opposite the spring firmly contacts the pump wall. The other two will be equally distant from it.
  - d. Align the jet assembly until the hole in the cap is in line with the tapped hole in the stand-off and the spacer bars are equidistant from the top of the pump.
  - e. Insert the retaining screw (Item 5) and tighten the assembly gently to secure the cap. *Do not use excessive force.*

## HS-2 Diffusion Pump

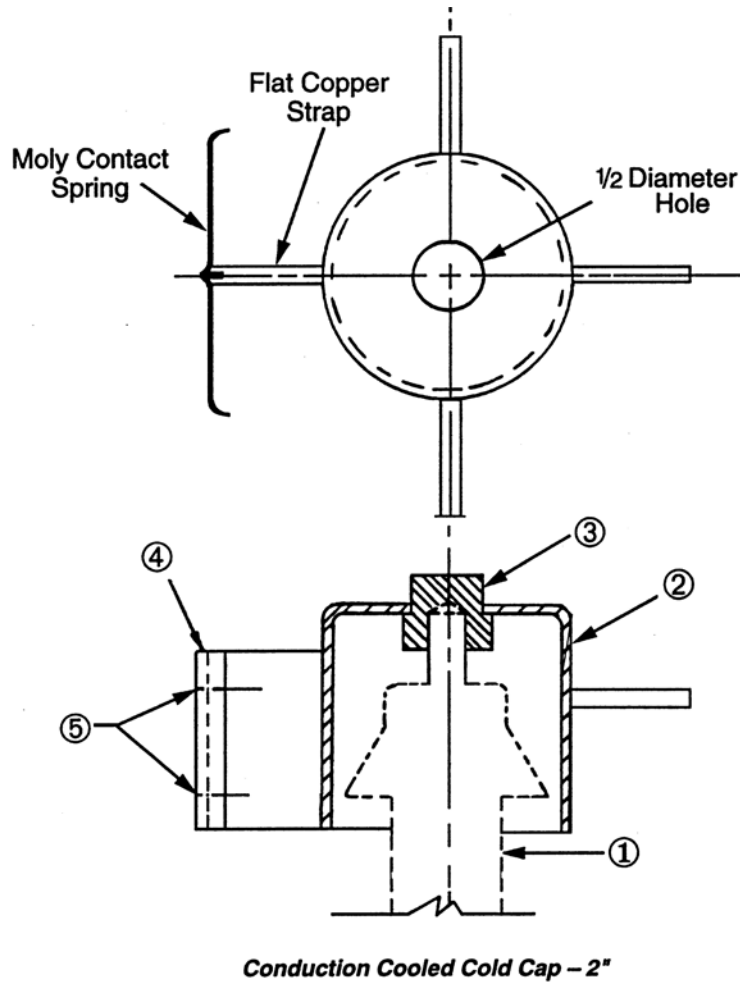

Figure 1-1 Cold Cap Installation

### Pump Fluid Installation

HS-2 diffusion pumps do not have fill and drain fittings. The pumps are filled by disconnecting the foreline manifold connection and introducing the appropriate amount of fluid, using a clean funnel and/or flexible tubing to guide the fluid to the bottom of the pump.

## HS-2 Diffusion Pump

### Maintenance

#### Changing Heater Element

If a change of heater is indicated by electrical tests:

1. Disconnect the electrical power leads to the heater terminal box of plug.
2. Remove the polished reflector cover.
3. Remove the block containing the defective heater.
4. Remove the heater from its hole and replace with a new element. Coat the replacement heater with milk of magnesia before inserting in the block. This prevents seizing of the element on repeated heat up, and make future servicing easier.
5. Reconnect the heater electrically and check continuity and rating.
6. Replace the polished reflector.

### HS-2 Diffusion Pump Specifications

This section gives the physical and operating specifications for the Model No. 82906301 (120 V) and 82906302 (240 V) pumps (Type No. 0160).

Figure 1-2 shows the HS-2 speed curve.

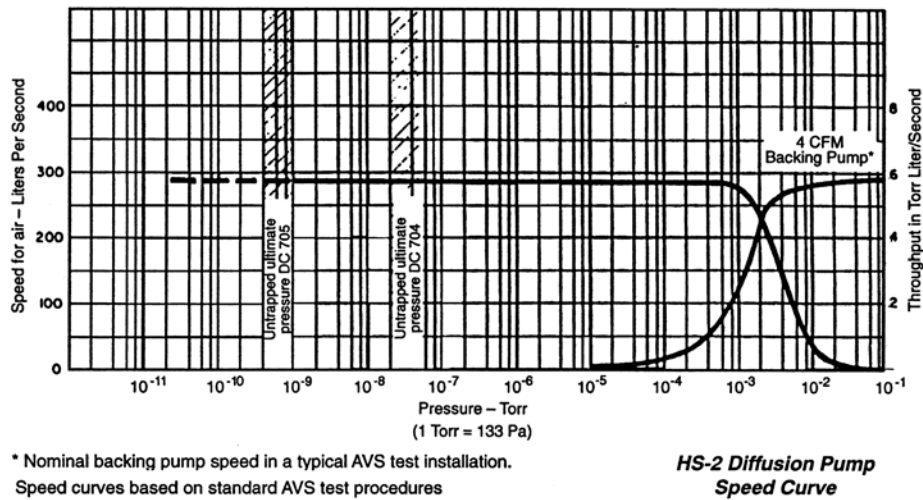

Figure 1-2 HS-2 Speed Curve

## HS-2 Diffusion Pump

Figure 1-3 shows the HS-2 cross section.

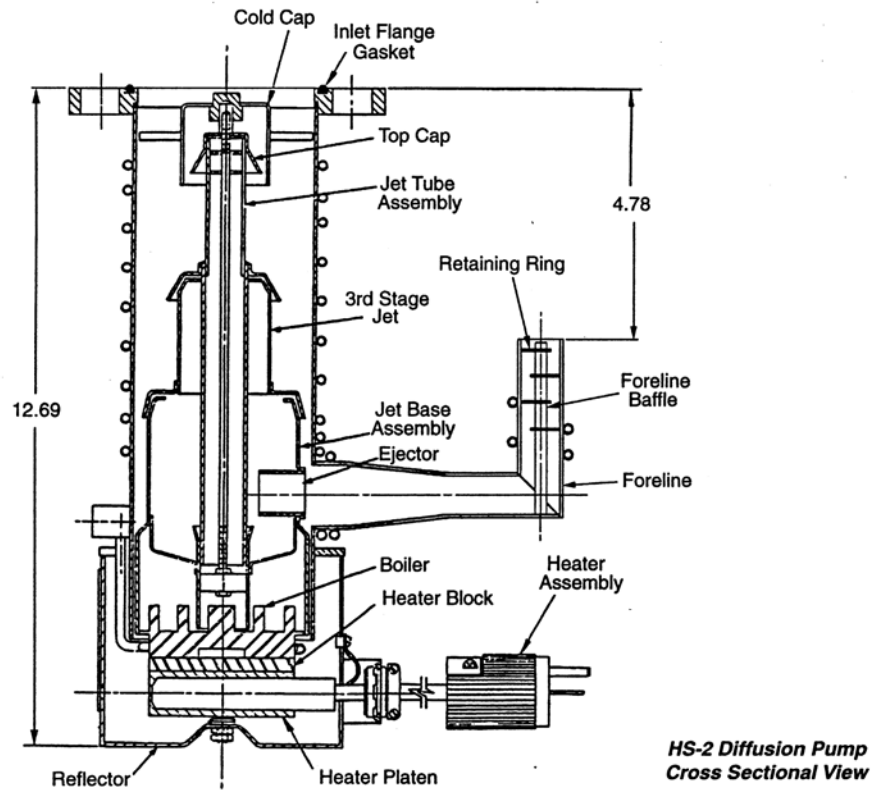
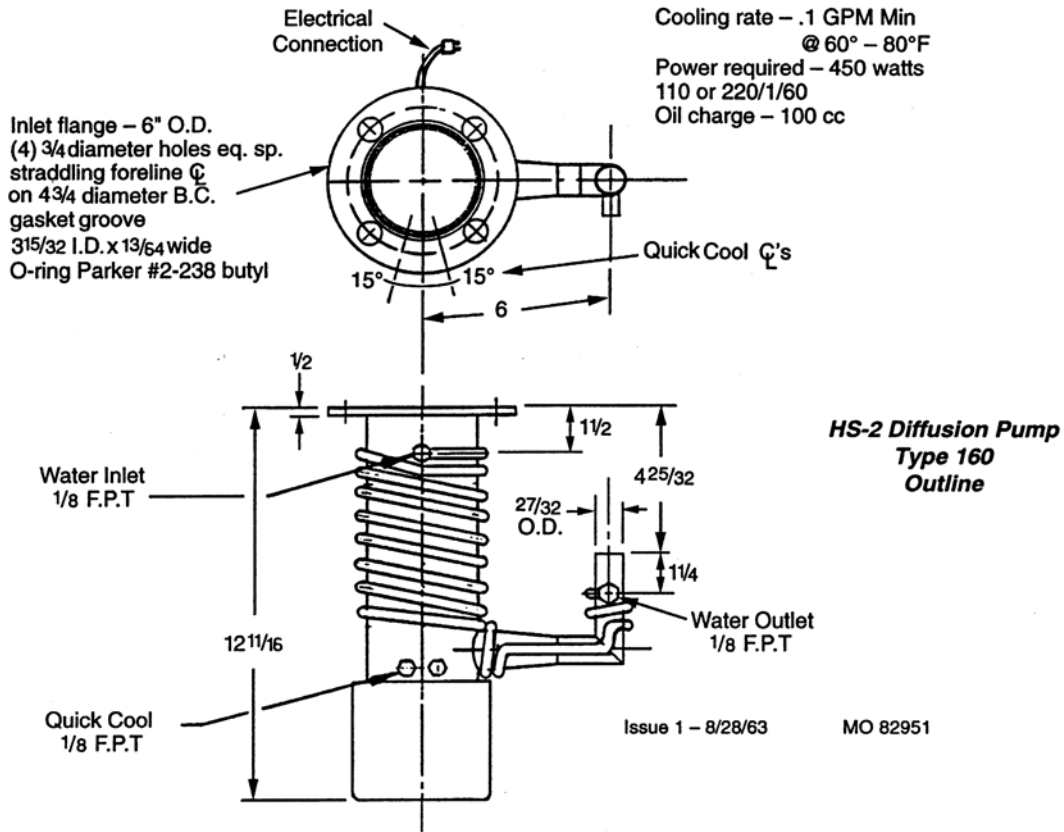

Figure 1-3 HS-2 Cross Section

## HS-2 Diffusion Pump

Figure 1-4 shows the HS-2 flange and pump dimensions and connections.



**Figure 1-4 HS-2 Flange and Pump**

### Operating Specifications

Table 1-1 gives the HS-2 operating specifications.

**Table 1-1 Operating Specifications**

Specification	Value
Optimum Operating Range	$2 \times 10^{-3}$ Torr (2.7 mbar) to $< 5 \times 10^{-8}$ Torr (6.7 mbar)
Maximum Pumping Speed	285 liters/second for air
Maximum Forepressure	No Load $5.5 \times 10^{-1}$ Torr (.73 mbar) Full Load $4.0 \times 10^{-1}$ Torr (.53 mbar)
Maximum Throughput	0.5 Torr liter/second (.67 mbar)
Backstreaming Rate at Pump Inlet	$1 \times 10^{-3}$ mg/cm <sup>2</sup> /min (with cold cap)
Power Required (Approximately)	450 W

## HS-2 Diffusion Pump

**Table 1-1 Operating Specifications (Continued)**

Specification	Value
Heat-up Time	15 minutes
Cool-down Time	Less than 5 minutes to <i>break jet</i> Less than 10 minutes to vent pump
Fluid Charge	100 cc. All conventional and high performance pump fluids
Cooling Water Requirements	0.1 gpm at 60 °F to 80 °F (15.6 °C to 26.7 °C) inlet temperature
Backing Pump Size	5 cfm or larger for optimum throughput

### PHYSICAL SPECIFICATIONS

Table 1-2 gives the HS-2 physical specifications.

**Table 1-2 Physical Specifications**

Specification	Value
Inlet Flange Connection	<ul style="list-style-type: none"> <li><input type="checkbox"/> OD – 6"</li> <li><input type="checkbox"/> ID – 311/32"</li> <li><input type="checkbox"/> Thickness – 1/2"</li> <li><input type="checkbox"/> Bolt Circle – 43/4 diameter</li> <li><input type="checkbox"/> No. of Holes – 4</li> <li><input type="checkbox"/> Size of Holes – 3/4 diameter</li> <li><input type="checkbox"/> Orientation – Straddle</li> <li><input type="checkbox"/> Gasket Groove – 315/32 ID x 13/64 wide</li> <li><input type="checkbox"/> Gasket O-Ring – Parker #2-238 Butyl</li> </ul>
Foreline Connection	<ul style="list-style-type: none"> <li><input type="checkbox"/> Tubing – 0.840 OD*</li> <li><input type="checkbox"/> Height – 1211/16" allow additional 31/2" for heater removal</li> <li><input type="checkbox"/> Jet Assembly – Self-aligning, fractionating design with 3 diffusion stages and one ejector stage</li> <li><input type="checkbox"/> Foreline Baffle – Stacked half moons with snap ring retainer</li> <li><input type="checkbox"/> Cold Cap - Conduction cooled</li> <li><input type="checkbox"/> Water Connections - 1/8 FPT body and quick cool.</li> </ul>



## HS-2 Diffusion Pump

**Table 1-2 Physical Specifications (Continued)**

Specification	Value
Materials of Construction	<input type="checkbox"/> Body – Stainless Steel <input type="checkbox"/> Flange – Mild Steel <input type="checkbox"/> Jet Assembly – Stainless Steel <input type="checkbox"/> Foreline Baffle – Stainless Steel <input type="checkbox"/> Cooling Coils – Copper, Welded to body <input type="checkbox"/> Heater Reflector – Polished Aluminum <input type="checkbox"/> Cold Cap – Copper, Nickel-Plated
Heater, Cartridge Type	<input type="checkbox"/> STD Voltage (Nom.)– 115V 1ø <input type="checkbox"/> Option (Nom.) – 240V 1ø <input type="checkbox"/> Power – 450 W (approximately) <input type="checkbox"/> Connector – Plug-in, 115 V, mates with Hubbell #5269 <input type="checkbox"/> 240 V mates with Hubbell #5669
Actual Weight	10 lbs
Shipping Weight	20 lbs
*(Use 5/8 ID x 1 3/8 OD rubber hose for vacuum service)	

## Optional Components

Table 1-3 gives the HS-2 optional components.

**Table 1-3 Optional Components**

Part Number	Description
647302150	Heater, 450 W, 240 V
F0600301	Cold Cap (Conduction cooled)

## HS-2 Diffusion Pump

---

### Replaceable Parts

When ordering replacement parts, quote type number and serial number of pump.

Table 1-4 gives the HS-2 replacement parts.

**Table 1-4 Replacement Parts**

<b>Part Number</b>	<b>Description</b>
647302124	Heater Assembly, 450 W, 120 V
647302150	Heater Assembly, 450 W, 240 V
82920001	Heater Block
82918301	Heater Platen
K0377159	O-ring Kit
F0310301	Jet Assembly
82917301	Reflector
F0600301	Cold Cap Assembly
84166301	Foreline Baffle
660156010	Baffle Retaining Ring
648018010	Heater Clip
Standard Heater Clip Screws	#4-40 x 3/16 Rd. Hd. MS M/S Ni-Plated
Standard Reflector Nuts	10-32 Hex Hd. S/S
Standard Reflector Washers	#10 Std Flat – S/S
Standard Heater Screws	1/4 - 20 x 1 3/8, Hex. Hd. Cap Screw/Lock Washer - S/S

## HS-2 Diffusion Pump

---

Table 1-5 lists the cold cap replacement parts.

**Table 1-5 Cold Cap Replacement Parts**

<b>Part Number</b>	<b>Description</b>
F0310301	Jet Assembly
F0600301	Cold Cap
F0597001	Teflon Button
F0600004	Moly. Spring
614120052	2-56 x 1/8" R.H.M.S. SS

## HS-2 Diffusion Pump

---

*This page intentionally left blank.*



*Request for Return  
Health and Safety Certification*



- Return authorization numbers (RA#) **will not** be issued for any product until this Certificate is completed and returned to a Varian, Inc. Customer Service Representative.
- Pack goods appropriately and drain all oil from rotary vane and diffusion pumps (for exchanges please use the packing material from the replacement unit), making sure shipment documentation and package label clearly shows assigned Return Authorization Number (RA#) VVT cannot accept any return without such reference.
- Return product(s) to the nearest location:

**North and South America**

Varian, Inc.  
Vacuum Technologies  
121 Hartwell Ave.  
Lexington, MA 02421  
Fax: (781) 860-9252

**Europe and Middle East**

Varian S.p.A.  
Via F.lli Varian, 54  
10040 Leini (TO) – ITALY  
Fax: (39) 011 997 9350

**Asia and ROW**

Varian Vacuum Technologies  
Local Office

For a complete list of phone/fax numbers see [www.varianinc.com/vacuum](http://www.varianinc.com/vacuum)

- If a product is received at Varian, Inc. in a contaminated condition, **the customer is held responsible** for all costs incurred to ensure the safe handling of the product, and **is liable** for any harm or injury to Varian, Inc. employees occurring as a result of exposure to toxic or hazardous materials present in the product.

<i>CUSTOMER INFORMATION</i>			
Company name: .....			
Contact person:	Name: .....	Tel: .....	
	Fax: .....	E-mail: .....	
Ship method:	Shipping Collect #: .....	P.O.#: .....	
Europe only:	VAT Reg Number: .....	USA only:	<input type="checkbox"/> Taxable <input type="checkbox"/> Non-taxable
Customer ship to:	.....	Customer bill to:	.....
	.....		.....
	.....		.....

*PRODUCT IDENTIFICATION*

Product Description	Varian, Inc. Part Number	Varian, Inc. Serial Number

*TYPE OF RETURN (check appropriate box)*

<input type="checkbox"/> Paid Exchange	<input type="checkbox"/> Paid Repair	<input type="checkbox"/> Warranty Exchange	<input type="checkbox"/> Warranty Repair	<input type="checkbox"/> Loaner Return
<input type="checkbox"/> Credit	<input type="checkbox"/> Shipping Error	<input type="checkbox"/> Evaluation Return	<input type="checkbox"/> Calibration	<input type="checkbox"/> Other

*HEALTH and SAFETY CERTIFICATION*

<b>VACUUM TECHNOLOGIES CANNOT ACCEPT ANY BIOLOGICAL HAZARDS, RADIOACTIVE MATERIAL, ORGANIC METALS, OR MERCURY AT ITS FACILITY. CHECK ONE OF THE FOLLOWING:</b>		
<input type="checkbox"/> I confirm that the above product(s) has (have) <b>NOT</b> pumped or been exposed to any toxic or dangerous materials in a quantity harmful for human contact.		
<input type="checkbox"/> I declare that the above product(s) has (have) pumped or been exposed to the following toxic or dangerous materials in a quantity harmful for human contact ( <u>Must be filled in</u> ):		
Print Name.....	Signature .....	Date .....

**PLEASE FILL IN THE FAILURE REPORT SECTION ON THE NEXT PAGE**

Do not write below this line

Notification (RA) #: ..... Customer ID #: ..... Equipment #: .....

**FAILURE REPORT**

(Please describe in detail the nature of the malfunction to assist us in performing failure analysis):

**TURBO PUMPS AND TURBOCONTROLLERS**

Claimed Defect	Position	Parameters
<input type="checkbox"/> Does not start <input type="checkbox"/> Does not spin freely <input type="checkbox"/> Does not reach full speed <input type="checkbox"/> Mechanical Contact <input type="checkbox"/> Cooling defective	<input type="checkbox"/> Noise <input type="checkbox"/> Vibrations <input type="checkbox"/> Leak <input type="checkbox"/> Overtemperature <input type="checkbox"/> Clogging	<input type="checkbox"/> Vertical <input type="checkbox"/> Horizontal <input type="checkbox"/> Upside-down <input type="checkbox"/> Other .....
		Power:                      Rotational Speed: Current:                    Inlet Pressure: Temp 1:                      Foreline Pressure: Temp 2:                      Purge flow: Operation Time:
Describe Failure:		
Turbocontroller Error Message:		

**ION PUMPS/CONTROLLERS**

<input type="checkbox"/> Bad feedthrough <input type="checkbox"/> Vacuum leak <input type="checkbox"/> Error code on display	<input type="checkbox"/> Poor vacuum <input type="checkbox"/> High voltage problem <input type="checkbox"/> Other .....
Describe failure:	
Customer application:	

**VALVES/COMPONENTS**

<input type="checkbox"/> Main seal leak <input type="checkbox"/> Solenoid failure <input type="checkbox"/> Damaged sealing area	<input type="checkbox"/> Bellows leak <input type="checkbox"/> Damaged flange <input type="checkbox"/> Other .....
Describe failure:	
Customer application:	

**LEAK DETECTORS**

<input type="checkbox"/> Cannot calibrate <input type="checkbox"/> Vacuum system unstable <input type="checkbox"/> Failed to start	<input type="checkbox"/> No zero/high background <input type="checkbox"/> Cannot reach test mode <input type="checkbox"/> Other .....
Describe failure:	
Customer application:	

**INSTRUMENTS**

<input type="checkbox"/> Gauge tube not working <input type="checkbox"/> Communication failure <input type="checkbox"/> Error code on display	<input type="checkbox"/> Display problem <input type="checkbox"/> Degas not working <input type="checkbox"/> Other .....
Describe failure:	
Customer application:	

**ALL OTHER VARIAN, INC.**

<input type="checkbox"/> Pump doesn't start <input type="checkbox"/> Doesn't reach vacuum <input type="checkbox"/> Pump seized	<input type="checkbox"/> Noisy pump (describe) <input type="checkbox"/> Overtemperature <input type="checkbox"/> Other .....
Describe failure:	
Customer application:	

**DIFFUSION PUMPS**

<input type="checkbox"/> Heater failure <input type="checkbox"/> Doesn't reach vacuum <input type="checkbox"/> Vacuum leak	<input type="checkbox"/> Electrical problem <input type="checkbox"/> Cooling coil damage <input type="checkbox"/> Other .....
Describe failure:	
Customer application:	



## Sales and Service Offices

### Canada

#### Central coordination through:

Varian, Inc.  
121 Hartwell Avenue  
Lexington, MA 02421  
USA  
Tel: (781) 861 7200  
Fax: (781) 860 5437  
Toll Free: (800) 882 7426

### China

#### Varian Technologies - Beijing

Room 1201, Jinyu Mansion  
No. 129A, Xuanwumen Xidajie  
Xicheng District  
Beijing 1000031  
P.R. China  
Tel: (86) 10 6608 1031  
Fax: (86) 10 6608 1541

### France and Benelux

#### Varian s.a.

7 avenue des Tropiques  
Z.A. de Courtaboeuf – B.P. 12  
Les Ulis cedex (Orsay) 91941  
France  
Tel: (33) 1 69 86 38 13  
Fax: (33) 1 69 28 23 08

### Germany and Austria

#### Varian Deutschland GmbH

Alsfelder Strasse 6  
Postfach 11 14 35  
64289 Darmstadt  
Germany  
Tel: (49) 6151 703 353  
Fax: (49) 6151 703 302

### India

#### Varian India PVT LTD

101-108, 1st Floor  
1010 Competent House  
7, Nangal Raya Business Centre  
New Delhi 110 046  
India  
Tel: (91) 11 5548444  
Fax: (91) 11 5548445

### Italy

#### Varian, Inc.

Via F.lli Varian, 54  
10040 Leini, (Torino)  
Italy  
Tel (39) 011 997 9 111  
Fax (39) 011 997 9 350

### Japan

#### Varian, Inc.

Sumitomo Shibaura Building, 8th Floor  
4-16-36 Shibaura  
Minato-ku, Tokyo 108  
Japan  
Tel: (81) 3 5232 1253  
Fax: (81) 3 5232 1263

### Korea

#### Varian Technologies Korea, Ltd.

Shinsa 2nd Building 2F  
966-5 Daechi-dong  
Kangnam-gu, Seoul  
Korea 135-280  
Tel: (82) 2 3452 2452  
Fax: (82) 2 3452 2451

### Mexico

#### Varian S.A.

Concepcion Beistegui No 109  
Col Del Valle  
C.P. 03100  
Mexico, D.F.  
Tel: (52) 5 523 9465  
Fax: (52) 5 523 9472

### Russia

#### Central coordination through:

Varian, Inc.  
via F.lli Varian 54  
10040 Leini, (Torino)  
Italy  
Tel: (39) 011 997 9 252  
Fax: (39) 011 997 9 316

### Taiwan

#### Varian Technologies Asia Ltd.

18F-13 No.79, Hsin Tai Wu Road  
Sec. 1, Hsi Chih, Taipei Hsien  
Taiwan, R.O.C.  
Tel: (886) 2 2698 9555  
Fax: (886) 2 2698 9678

### UK and Ireland

#### Varian Ltd.

28 Manor Road  
Walton-On-Thames  
Surrey KT 12 2QF  
England  
Tel: (44) 1932 89 8000  
Fax: (44) 1932 22 8769

### United States

#### Varian, Inc.

121 Hartwell Avenue  
Lexington, MA 02421  
USA  
Tel: (781) 861 7200  
Fax: (781) 860 5437

### Other Countries

#### Varian, Inc.

Via F.lli Varian 54  
10040 Leini, (Torino)  
Italy  
Tel: (39) 011 997 9 111  
Fax: (39) 011 997 9 350

### Customer Support and Service:

#### North America

Tel: 1 (800) 882-7426 (toll-free)  
vtl.technical.support@varianinc.com

#### Europe

Tel: 00 (800) 234 234 00 (toll-free)  
vtl.technical.support@varianinc.com

#### Japan

Tel: (81) 3 5232 1253 (dedicated line)  
vtj.technical.support@varianinc.com

#### Korea

Tel (82) 2 3452 2452 (dedicated line)  
vtk.technical.support@varianinc.com

#### Taiwan

Tel: 0 (800) 051 342 (toll-free)  
vtw.technical.support@varianinc.com

### Worldwide Web Site, Catalog and On-line Orders:

[www.varianinc.com](http://www.varianinc.com)

Representatives in most countries



**VARIAN**

