

EDWARDS APG100 Active Pirani Gauge

Description	Item Number
APG100 - XM NW16	D026-01-000
APG100 - XM NW25	D026-02-000
APG100 - XLC NW16	D026-03-000
APG100 - XLC NW25	D026-04-000



1. Electrical connector
2. Set-point button
3. Cal button
4. Status LED
5. Electronics housing
6. Vacuum flange

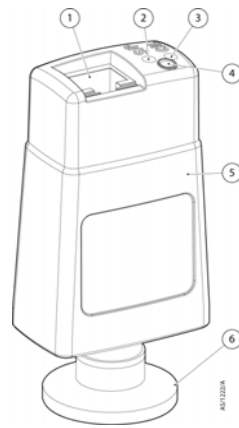

Figure 1 - General view of the APG100

Instruction Manual	
D026-01-880 Iss B	Jan 09

Introduction

Scope and definitions

This manual provides installation, operation and maintenance instructions for the Edwards APG100 Active Pirani Gauge. You must use the APG100 as specified in this manual.

Read this manual before you install and operate the APG100. Important safety information is highlighted as **WARNING** and **CAUTION** instructions; you must obey these instructions. The use of **WARNINGS** and **CAUTIONS** is defined below.

WARNING
Warnings are given where failure to observe the instruction could result in injury or death to people.

CAUTION
Cautions are given where failure to observe the instruction could result in damage to the equipment, associated equipment and process.

The following symbols appear on the APG100:

- Warning - refer to accompanying documents.
- Edwards offer European customers a recycling service.

Description

The APG100 is a Pirani gauge which measures vacuum pressures in the range 10⁻⁴ mbar to 1000 mbar. It operates using the principle of thermal conductivity in which the rate of heat loss from a heated filament is dependent on the pressure of gas surrounding the filament.

The APG100 is available in two versions: the 'M' version can measure pressure down to 10⁻³ mbar and is suitable for general applications; the 'LC' version can measure pressure down to 10⁻⁴ mbar and is also suitable for use in corrosive applications.

A general view of the gauge is shown in Figure 1. The gauge features a detachable tube which allows a replacement to be fitted in the event of contamination or failure of the filament. There are two push-button switches on the top of the gauge. The switch labelled "CAL" is used for atmosphere and vacuum calibration and the switch labelled "S/P" is used to adjust the set-point threshold.

Technical Data

Mechanical data

Dimensions	Refer to Figure 2
Mass:	
NW16 versions	85 g
NW25 versions	100 g
Internal volume of tube	5 cm ³
Enclosure rating	IP40

Performance, operating and storage conditions

Measurement range	
APG100-XM	10 ⁻³ to 1000 mbar
APG100-XLC	10 ⁻⁴ to 1000 mbar
Accuracy	
APG100-XM	typically ± 15 % at < 100 mbar
APG100-XLC	typically ± 15 % at < 10 mbar
Ambient temperature	
Operating	5 to 60 °C
Storage	-30 to +70 °C
Bakeout temperature	150 °C (with electronics housing removed)
Humidity	80 % RH up to 31 °C decreasing linearly to 50 % RH at 40 °C and above
Maximum altitude	3000 m (indoor use only)
Maximum internal pressure	10 bar absolute (9 bar gauge)
Filament temperature	100 °C above ambient

Electrical data

Electrical supply voltage	15 to 30 V d.c. nominal 13.5 V minimum 32 V maximum
Maximum power consumption	1 W
Max inrush current	150 mA
Electrical connector	FCC68 / RJ45 8-way
Pressure output signal	
Range	1.9 to 9.1 V
Error range	output < 1.8 V or output > 9.2 V
Min load impedance	10 kΩ
Max output current	1 mA
Set-point	
Adjustment range	1.8 to 9.2 V
Hysteresis	500 mV
Max external load rating	30 V d.c., 100 mA
Gauge identification resistance	
APG100-XM	36 kΩ
APG100-XLC	43 kΩ

Materials exposed to vacuum

Filament	
APG100-XM	Tungsten / Rhenium
APG100-XLC	Platinum / Iridium
Tube	Stainless Steel 316L & 304L
Filter	Stainless Steel 316L
Other	Glass, Ni, NiFe, PTFE (APG100-XLC only)

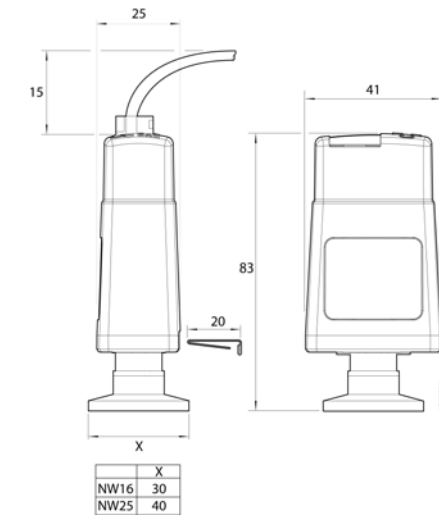

Figure 2 - Dimensions (mm)

Installation

Unpack and inspect

Remove all packing materials and protective covers. Check the APG100. If the APG100 is damaged, notify your supplier and carrier in writing within three days: state the Item Number of the gauge together with your order number and your suppliers invoice number. Retain all packing materials for inspection. Do not use the APG100 if it is damaged.

If the APG100 is not to be used immediately, replace the protective covers. Store the APG100 in suitable conditions as described in Technical Data section.

Fit the APG100 to a vacuum system

WARNING
You must use a Co-seal or trapped 'O' ring carrier to connect an APG100 to a vacuum system if the pressure is likely to exceed atmospheric pressure. Standard centring rings are not suitable for use above atmospheric pressure.

WARNING
Do not use the APG100 for safety critical applications. The APG100 is not intended to be fail-safe.

The APG100 can be mounted in any orientation however the gauge tubes are individually factory calibrated in nitrogen whilst vertical. For correct pressure indication in your chosen gauge orientation, the gauge should be recalibrated at atmospheric pressure. Edwards recommends mounting the gauge tube vertical in order to minimise the build up of process particulates and condensable vapours within the gauge.

For optimum accuracy it is recommended that both the atmosphere and vacuum adjustment is carried out before use. Refer to the Maintenance section.

To connect the APG100 to your vacuum system:

- Use an 'O' ring / centring-ring or Co-Seal to connect an APG100 with an NW16 or NW25 flange to a similar flange on the vacuum system.
- Use a stepped 'O' ring carrier or Co-Seal to connect an APG100 with an NW16 flange to an NW10 flange.

In accordance with good practice, we recommend that your vacuum system has a secure Earth (ground) connection, and that the tube of the APG100 is electrically connected to the vacuum system.

Connect to an Edwards Controller

The APG100 is compatible with the TIC and ADC digital controllers and the AGD analogue display from Edwards. The controllers will automatically recognise the gauge and display the measured pressure.

To connect to a Edwards controller use a cable which is terminated in suitable connectors. These cables are available from Edwards.

Connect to your own electrical equipment

CAUTION
Do not make any connection to the gauge identification pin (pin 4) as this may cause the gauge to malfunction.

A schematic diagram of the recommended electrical connections to the APG100 is shown in Figure 4. The pins on the electrical connector are used as shown in Table 1. Refer to the Technical Data section for more detailed specifications.

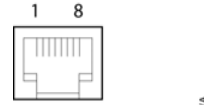
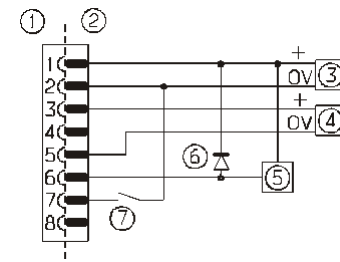

Figure 3 - RJ45 8-way connector

Pin number	Use
1	Electrical supply positive
2	Electrical supply ground (0 V)
3	Pressure measurement output signal
4	Gauge identification
5	Signal ground
6	Set-point output signal
7	Remote calibration input
8	Not connected

Table 1 - Pins on the APG100 electrical connector



1. APG100 electrical connector socket
2. Cable electrical connector plug
3. Electrical supply
4. Voltmeter
5. d.c. relay (optional)
6. Back EMF suppression diode (optional)
7. Remote calibration switch (optional)

Figure 4 - Recommended electrical connections

Do not connect the electrical supply ground (pin 2) to the signal ground (pin 5). If you do, the APG100 output signal will be inaccurate.

When using the APG100 in an electrically noisy environment you should ensure that your measuring equipment is adequately immune to interference. All Edwards controllers have adequate immunity.

The set-point output on pin 6 is an active low open-collector transistor suitable for driving a d.c. relay or control logic. If you connect a relay you must use a suppression diode, to protect the gauge from transient voltages generated when the relay is switched off, as shown in Figure 4.

Make a connection to pin 7 if you require remote calibration. Momentarily (>50ms) connect pin 7 to pin 2 (ground) to automatically adjust the atmosphere or vacuum reading. Refer to the Maintenance section for the correct procedure.

Operation

WARNING
Do not use the APG100 to measure the pressure of explosive or flammable gases or mixtures. The gauge contains a heated filament which normally operates around 100°C above ambient temperature. The temperature of the filament can be substantially higher under fault conditions.

Pressure measurement

When the APG100 is connected to a power supply the status LED will turn amber for approximately 2 seconds. The status LED will then turn green if the gauge is operating correctly or red if an error is detected. Refer to the fault finding guide.

If the gauge is connected to a Edwards controller the display will indicate the measured pressure.

If the gauge is connected to a voltmeter convert the voltage (V) to pressure (P) using the following equations:

$$P = 10^{(V-6)}$$

$$P = 10^{(V-6.125)}$$

$$P = 10^{(V-4)}$$

$$P \text{ in mbar}$$

$$P \text{ in Torr}$$

$$P \text{ in Pa}$$

For example if the measured voltage V = 4 V, then the measured pressure P = 1 x 10⁻² mbar. Refer to Figures 5 and 6.

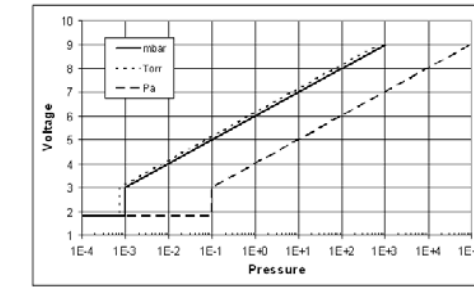

Figure 5 - Voltage to pressure conversion for APG100-XM

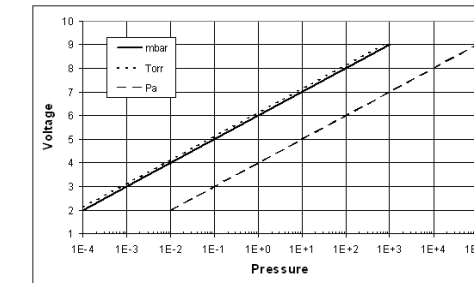

Figure 6 - Voltage to pressure conversion for APG100-XLC

Gas dependency

The APG100 is calibrated for use in nitrogen, and will read correctly with dry air, oxygen and carbon monoxide. For any other gas type a conversion is required in order to obtain the correct pressure reading. Figures 7 and 8 show the conversion for 6 common gases: nitrogen, argon, carbon dioxide, helium, krypton and neon.

If you are using a Edwards TIC controller, the gas calibration data is built into the controller.

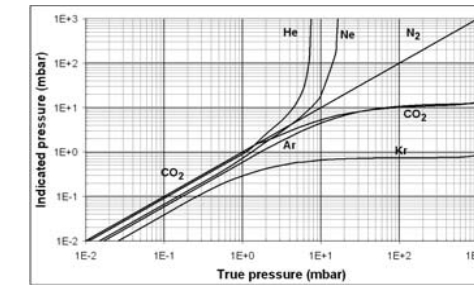

Figure 7 - Gas dependency of APG100-XM

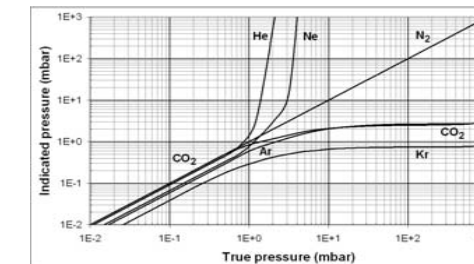

Figure 8 - Gas dependency of APG100-XLC

PLEASE CONTACT ANY OF THESE COMPANIES FOR DETAILS OF OTHER SALES AND SERVICE CENTRES IN YOUR AREA.

EUROPE/ UNITED KINGDOM
EDWARDS
Manor Royal
Crawley
West Sussex
RH10 9LW
Tel +44 (0)1293 528844
Fax +44 (0)1293 533453

AMERICAS
USA HEADQUARTERS
EDWARDS
One Edwards Park
301 Ballardvale Street
Wilmington, MA 01887
Tel +1 978 658 5410
Fax +1 978 658 7969
Toll free (USA only) 1 800 848 9800

CANADA
EDWARDS
5975 Falbourne Street
Mississauga, Ontario L5R3W6
Canada
Tel +1 800 387 4076
Fax +1 905 501 1225

GERMANY
EDWARDS
Ammerthalstraße 36
85551 Kirchheim
Munich
Tel +49 89 991 9180
Fax +49 89 991 91899

ITALY
EDWARDS
Via Carpaccio 35
20090 Trezzano sul Naviglio
Milan
Tel +39 02 48 4471
Fax +39 02 48 401638

EDWARDS
Wilhelm Klein GmbH
Eckenerstrasse 1
D-73730 Esslingen
Postfach 10 03 28
Tel +49 (0)711/93 18 30-0
Fax +49 (0)711/93 18 30-3

FRANCE
EDWARDS
125 Avenue Louis Roche
92238 Gennevilliers, Cedex
Paris
Tel +33 1 47 98 24 01
Fax +33 1 47 98 44 54

BELGIUM
EDWARDS
Bergensesteenweg 709
B1600 Sint-Pieters-Leeuw
Brussels
Tel +32 2 363 0030
Fax +32 2 363 00640

INDIA
EDWARDS
LTD
INDIA HEADQUARTERS
203 Surya Kiran Building
19 Kasturba Gandhi Marg
New Delhi - 110 001
India
Tel +91 11 5151 0065
Fax +91 11 5151 0245

ISRAEL
EDWARDS ISRAEL VACUUM
LTD
5 Habarzel Boulevard
Gat 2000 Industrial Zone
Qiryat Gat 82000
Israel
Tel +972 8 681 0633
Fax +972 8 681 0640

BRAZIL
DO BRASIL LTDA
Rua Bernardo Wrona 222
02710 São Paulo-SP
Brazil
Tel +55 11 3952 5000
Fax +55 11 3965 2766

JAPAN
HEADQUARTERS
EDWARDS
5F Sanshikaikan Building
1-9-4 Yurakucho Chiyoda-Ku
Tokyo, 100-0006
Tel +81 (0)3 6212 6771
Fax +81 (0)3 6212 6780

CHINA
EDWARDS TRADING
(SHANGHAI) CO. LTD.
23 Fu Te Road (N)
Wai Gao Qiao Free Trade Zone
Pudong
Shanghai, 200131
PRC China
Tel +86 21 5866 9618
Fax +86 21 5866 9993

KOREA
HEADQUARTERS
SONGWON EDWARDS LTD.
5th FL, Daewoo Engineering Bldg.
9-3 Sunae-dong
Bundang-gu, Sungnam City
Kyungki-do
Korea
Tel +82 31 716 7070
Fax + 82 31 738 1001

TAIWAN, R.O.C.
EDWARDS TAIWAN LIMITED
No. 434 Chung hua Road
Toufen Town, Miaoli County
351 Taiwan
Tel +886 37 611422
Fax +886 37 611401

SINGAPORE
EDWARDS (ASIA)
42 Loyang Drive
Loyang Industrial Estate
Singapore 508962
Tel +65 6546 8408
Fax +65 6546 8407

For pressures below 1mbar a simple calibration factor can be used to correct for different gas types. Gas Calibration Factors (GCFs) for common gases are shown in Table 2.

$$\text{True pressure} = \text{GCF} \times \text{indicated pressure}$$

Gas	GCF
He	1.1
Ne	1.5
N ₂	1.0
Ar	1.7
CO ₂	1.0
Kr	2.6

Table 2 - Gas calibration factors below 1 mbar

Set-point adjustment

CAUTION

When the 'S/P' button is pushed the gauge output will change. Do not push the 'S/P' button to adjust the set-point if the change in output could cause a malfunction of your system.

Note: If you use an Edwards Controller the APG100 set-point is not used.

To read the pressure at which the set-point output turns on, push the "S/P" button with an appropriate tool (see Figure 9). The signal output of the gauge will change to indicate the set-point threshold for three seconds after which the output will return to normal.

15

The set-point has a fixed hysteresis of 500mV. When the measured pressure falls below the set-point pressure the transistor output changes to ON (closed). The transistor output will turn OFF when the measured pressure rises to 500mV above the set-point pressure. An external relay connected as shown in Figure 4 will turn on when the pressure falls below the set-point and turn off when the pressure rises to 500 mV above the set-point.

To adjust the set-point threshold push the "S/P" button and hold it down for more than three seconds. The threshold value will increase steadily. Release the button when you reach the required value. To make finer adjustment release the button just before the required value is reached and immediately push the button as many times as required. Each time you push the button the threshold value will increase by 10mV. If during adjustment the threshold reaches the maximum value (9.2V) it will jump to the minimum (1.8V) and increase again.

If you do not need to use the set-point or if you require the set-point to be permanently off, you can adjust the threshold to 1.8V. This will ensure that the set-point does not operate. The APG100 is shipped from the factory with the threshold set to 1.8V.

The set-point can also be used to indicate that the gauge is operating correctly. If you adjust the threshold to 9.2V then the set-point output will be ON as long as the gauge is operating correctly and will turn OFF if an error is detected.

16

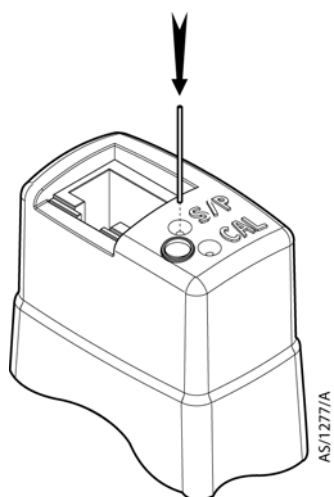

Figure 9 - Adjusting set-point

17

Error monitoring

If an error occurs during operation of the APG100 then the status LED will turn red to indicate an error and the output voltage will change to indicate the error condition. Error voltages are shown in Table 3 below. The set-point will be disabled as soon as an error is detected. Refer to the fault finding guide.

If you use an Edwards Controller then an error message will be shown on the display.

Error condition	Output (V)	TIC Display	ADC Display	AGC Display
Broken filament or tube removed	9.5	Filament Fail	Err 25	Err E
Calibration error	9.6	Cal Error	Err 26	Err F

Table 3 - Error indication

Bakeout

In some UHV applications it is desirable to bake the vacuum system components in order to achieve a lower base pressure. The tube of the APG100 can be baked to 150°C, but the electronics housing must be removed.

- Referring to Figure 12, remove the electronics housing.
- Bake the tube on your vacuum system. Do not exceed 150°C.
- Allow the tube to cool before refitting the electronics housing.

18

Maintenance

Atmosphere and vacuum adjustment

Every APG100 is individually adjusted before shipment, however thermal conductivity gauges can drift with time or as contamination builds up on the filament. Use the procedures outlined below to adjust the atmosphere and vacuum settings of the gauge. The frequency with which they should be repeated will vary depending on the level and nature of the contamination associated with the process.

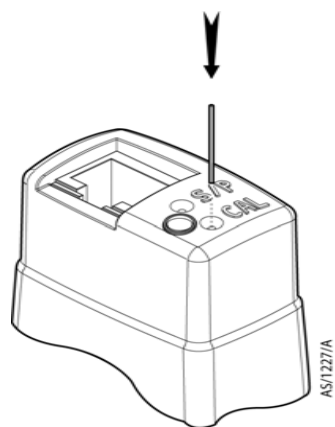

Figure 10 - Adjustment of APG100

19

Atmosphere adjustment

- Switch on the power supply to the APG100 and allow it to operate at atmospheric pressure for at least 10 minutes. Ensure that the green status LED is lit.
- Press the 'CAL' button. The status LED will flash and the gauge will automatically adjust to read atmospheric pressure. Do not hold the 'CAL' button down for longer than 5 seconds (see 'Adjustment for new tube' below).

Vacuum adjustment

- Reduce the system pressure to 1 x 10⁻⁴ mbar (or below) for the APG100-XM, or to 1x10⁻⁵ mbar (or below) for the APG100-XLC.
- Allow the gauge to operate for at least 10 minutes.
- Press the 'CAL' button. The status LED will flash and the gauge will automatically adjust to read vacuum.

Remote adjustment

The atmosphere and vacuum adjustments can be performed remotely using a switch connected as shown in Figure 4. Follow the procedure described above, but momentarily close the remote switch instead of using the 'CAL' button on the gauge. Edwards controllers use this feature so that the atmosphere and vacuum readings can be automatically adjusted from the front panel of the controller.

Adjustment for new tube

If a replacement tube is fitted to the gauge it will be necessary to adjust the gauge to match the new tube. Note that this is not required unless a new tube is fitted, and it is always necessary to perform a vacuum adjustment afterwards.

20

- Switch on the power supply to the APG100.
- With the gauge at atmospheric pressure, press the 'CAL' button and hold it down for longer than 5 seconds. The status LED will begin to flash red / green alternately and the gauge will automatically adjust to match the new tube. This may take several seconds.
- Allow the gauge to operate at atmospheric pressure for at least 10 minutes and then repeat step 2.
- It is now necessary to perform the vacuum adjustment as described above.

Replace the filter

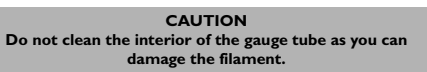

The filter that is fitted inside the vacuum flange of the gauge provides protection from process contamination. With use the filter can become dirty or blocked, and it will be necessary to replace the filter.

Refer to Figure 11 and follow this procedure to replace the filter.

- Unplug the electrical cable, vent the vacuum system to atmospheric pressure and remove the gauge from the vacuum system.
- Use circlip pliers to remove the retaining circlip. Take care not to damage the sealing surface of the vacuum flange or the inside of the gauge tube.
- Remove and discard the old filter.
- Refit the filter into the gauge tube and refit the circlip.

21

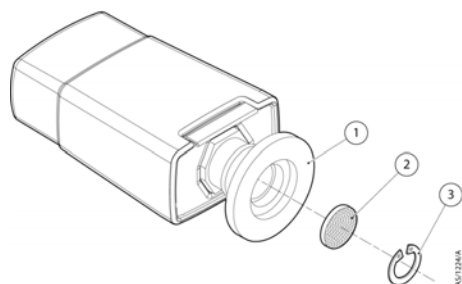

- Gauge tube
- Filter
- Circlip

Figure 11 - Replacement of filter

Replace the gauge tube

If the gauge tube has become severely contaminated so that atmosphere or vacuum adjustment cannot be achieved, or if the filament is broken, then you can fit a replacement tube to the gauge.

Refer to Figure 12 and follow this procedure to replace the gauge tube.

- Unplug the electrical cable, vent the vacuum system to atmospheric pressure and remove the gauge from the vacuum system.
- Pull the retaining clip from side of gauge.
- Pull the tube from the electronics housing.
- Fit the replacement tube into electronics housing, noting the correct alignment.
- Refit the retaining clip.

22

Whenever a new tube is fitted it is necessary to adjust the gauge to match the new tube. Refer to 'Adjustment for new tube' above.

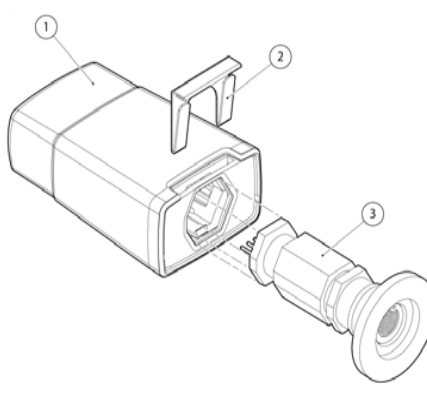

- Electronic housing
- Retaining clip
- Gauge tube

Figure 12 - Replacement of gauge tube

23

Fault finding guide

Symptom	Possible cause	Remedy
LED not lit	Incorrect electrical supply voltage. Supply polarity reversed.	Check electrical supply and connections
Pressure reading incorrect	Vacuum leak	Leak check vacuum system
	Tube has drifted and requires adjustment	Perform the atmosphere and vacuum adjustments
	Tube contaminated	Replace the tube
Gauge indicates calibration error	Adjustment has been attempted at an inappropriate pressure	Repeat the adjustment but make sure that the pressure is at atmosphere or good vacuum
	Wrong type of tube is fitted	Check that correct type of tube is fitted (M or LC)
	New tube has been fitted	Perform 'Adjustment for new tube'
	Tube has drifted outside permissible limits and can no longer be adjusted	Replace the tube
Gauge indicates broken filament	Tube is missing	Fit the tube and remove then re-insert the electrical connector
	Wrong type of tube is fitted	Check that correct type of tube is fitted (M or LC)
	Filament is broken	Replace the tube

Table 4 - Fault finding information

24

Calibration service

A calibration service is available for all Edwards gauges. Calibration is by comparison with reference gauges, traceable to National Standards. Contact Edwards for details.

Storage and Disposal

Dispose of the APG100 and any components safely in accordance with all local and national safety and environmental requirements.

Alternatively, you may be able to recycle the APG100 and cables: contact Edwards or your supplier for advice (also see below).

The APG100 and associated cables are within the scope of the European Directive on Waste Electrical and Electronic Equipment, 2002/96/EC. Edwards offers European customers a recycling service for the APG100 and cables at the end of the product's life. Contact Edwards for advice on how to return the APG100 and cables for recycling.

Particular care must be taken if the APG100 has been contaminated with dangerous process substances.

Spares and Accessories

Introduction

Edwards products, spares and accessories are available from Edwards companies in Belgium, Brazil, Canada, France, Germany, Hong Kong, Italy, Japan, Korea, Switzerland, United Kingdom, U.S.A. and a world wide network of distributors. The majority of these centres employ Service Engineers who have undergone comprehensive Edwards training courses.

25

Order spare parts and accessories from your nearest Edwards company or distributor. When you order, please state for each part required:

- Model and Item Number of your equipment
- Serial number (if any)
- Item Number and description of part

Spares

Spare	Item Number
Replacement electronics housing	
APG100-XM	D026-01-800
APG100-XLC	D026-03-800
Replacement tube	
APG100-XM NW16	D026-01-801
APG100-XM NW25	D026-02-801
APG100-XLC NW16	D026-03-801
APG100-XLC NW25	D026-04-801
Replacement Filter Kit	D026-01-805

Accessories

The cables for use with the APG100 are as follows. These cables are supplied with 8-way male electrical connectors on both ends.

Cable length	Item Number
0.5 m	D400-01-005
1 m	D400-01-010
3 m	D400-01-030
5 m	D400-01-050
10 m	D400-01-100
15 m	D400-01-150
25 m	D400-01-250
50 m	D400-01-500
100 m	D400-01-999

26

PROCEDURE

- Contact Edwards and obtain a Return Authorisation Number for your equipment.
 - Complete the Return of Edwards Equipment Declaration (HS2).
 - If the equipment is contaminated, you must contact your transporter to ensure that you properly classify the hazard, mark, manifest and ship the equipment, in accordance with applicable laws governing the shipment of contaminated/hazardous materials. As the person offering the equipment for shipment, it is your responsibility to ensure compliance with applicable law. Note: Equipment contaminated with some hazardous materials, such as semiconductor by-products, may not be suitable for airfreight - contact your transporter for advice.
 - Remove all traces of hazardous gases: pass an inert gas through the equipment and any accessories that will be returned to Edwards. Where possible, drain all fluids and lubricants from the equipment and its accessories.
 - Seal up all of the equipment's inlets and outlets (including those where accessories were attached) with blanking flanges or, for uncontaminated product, with heavy gauge tape.
 - Seal equipment in a thick polythene/polyethylene bag or sheet.
 - If the equipment is large, strap the equipment and its accessories to a wooden pallet. If the equipment is too small to be strapped to a pallet, pack it in a suitable strong box.
 - Fax or post a copy of the Declaration (HS2) to Edwards. The Declaration must arrive before the equipment.
 - Give a copy of the Declaration (HS2) to the transporter. You must tell your transporter if the equipment is contaminated.
 - Seal the original Declaration in a suitable envelope: attach the envelope securely to the outside of the equipment package, in a clear weatherproof bag.
- WRITE YOUR RETURN AUTHORISATION NUMBER CLEARLY ON THE OUTSIDE OF THE ENVELOPE OR ON THE OUTSIDE OF THE EQUIPMENT PACKAGE.**

Return of Edwards Equipment - Procedure

INTRODUCTION
Before returning your equipment, you must warn Edwards if substances you used (and produced) in the equipment can be hazardous. This information is fundamental to the safety of our Service Centre employees and will determine the procedures employed to service your equipment. Complete the Declaration (HS2) and send it to Edwards before you dispatch the equipment. It is important to note that this declaration is for Edwards internal use only, and has no relationship to local, national or international transportation safety or environmental requirements. As the person offering the equipment for shipment, it is your responsibility to ensure compliance with applicable laws.

GUIDELINES

- Equipment is 'uncontaminated' if it has not been used, or if it has only been used with substances that are not hazardous. Your equipment is 'contaminated' if it has been used with any substances classified as hazardous under EU Directive 67/548/EEC (as amended) or OSHA Occupational Safety (29 CFR 1910).
- If your equipment has been used with radioactive substances, biological or infectious agents, mercury, polychlorinated biphenyls (PCBs), dioxins or sodium azide, you must decontaminate it before you return it to Edwards. You must send independent proof of decontamination (for example a certificate of analysis) to Edwards with the Declaration (HS2). Phone Edwards for advice.
- If your equipment is contaminated, you must either:
 - Remove all traces of contamination (to the satisfaction of laws governing the transportation of dangerous/hazardous substances).
 - Or, properly classify the hazard, mark, manifest and ship the equipment in accordance with applicable laws governing the shipment of hazardous materials.

Note: Some contaminated equipment may not be suitable for airfreight.