

Instruction Manual

Active Thermocouple Gauge

Description	Item Number
ATC-E	D351-08-000

Original Instructions





Declaration of Conformity

We, Edwards Limited,
Crawley Business Quarter,
Manor Royal,
Crawley,
West Sussex, RH10 9LW, UK

declare under our sole responsibility, as manufacturer and person within the EU authorised to assemble the technical file, that the product(s)

- Active Thermocouple Gauge D351-08-000

to which this declaration relates is in conformity with the following standard(s) or other normative document(s)

EN61326-2-3: 2013 (Class B Emissions, Basic Immunity)	Electrical equipment for measurement, control and laboratory Use. EMC requirements. Particular requirements. Test configuration, operational conditions and performance criteria for transducers with integrated or remote signal conditioning
EN50581: 2012	Technical Documentation for the Assessment of Electrical and Electronic Products with respect to the Restriction of Hazardous Substances

and fulfils all the relevant provisions of

2014/30/EU	Electromagnetic Compatibility (EMC) Directive
2011/65/EU	Restriction of Certain Hazardous Substances (RoHS) Directive
2012/19/EU	Waste Electrical and Electronic Equipment (WEEE) Directive

Note: This declaration covers all product serial numbers from the date this Declaration was signed onwards.

Larry Marini, Senior Technical Manager

19.08.2015, Eastbourne

Date and Place

This product has been manufactured under a quality management system certified to ISO 9001:2008

Contents

Section	Page
1	Introduction 1
1.1	Scope of this manual 1
1.2	General 1
2	Technical data 3
2.1	Operating conditions 3
2.2	Performance 3
2.2.1	Output signal 3
2.2.2	setpoint 3
2.2.3	Gauge identification signal 3
2.3	Mechanical data 4
2.4	Electrical data 4
2.4.1	Electrical supply data 4
2.4.2	Electronic interface 4
2.5	Thermocouple gauge tubes 4
2.5.1	Materials exposed to vacuum 4
2.5.2	Colour coding 5
2.5.3	Pressure range 5
2.5.4	Thermocouple temperature 5
2.5.5	Maximum internal overpressure 5
3	Installation 7
3.1	Unpacking and inspection 7
3.2	Connection to the vacuum system 7
3.3	Positioning the gauges 7
3.4	Electrical connection 7
3.5	Gauge setpoint trip 7
3.5.1	Adjustment 7
3.5.2	Trip output 8
4	Operation 13
4.1	Reading the pressure 13
4.2	Gas dependency 13
5	Maintenance 15
5.1	General 15
5.2	Fault finding 15
6	Storage and disposal 17
6.1	Storage 17
6.2	Disposal 17
7	Accessories 19
7.1	Introduction 19
7.2	Accessories 19
7.2.1	Cables 19
7.3	ATC spares 19

For return of equipment, complete the HS Forms at the end of this manual.

Illustrations

Figure	Page
1 General view of gauge	9
2 Connection to external power supply	10
3 Connection of external relay	10

Tables

Table	Page
1 Pressure/voltage characteristic for DV4D	11
2 Pressure/voltage characteristic for DV6M	12

1 Introduction

1.1 Scope of this manual

This manual provides installation, operation and routine maintenance instructions for the Edwards Active Thermocouple Gauge. Read this manual before installing and operating the gauge.

This manual contains essential safety information which supplements the safety features of the gauge. Safety procedures are highlighted as WARNING and CAUTION instructions. You must obey these instructions. The use of WARNINGS and CAUTIONS is defined below.



WARNING

Warnings are given where failure to observe the instruction could result in injury or death to people.

CAUTION

Cautions are given where failure to observe the instruction could result in damage to the equipment, associated equipment and process.

The following labels appear on the gauge:



Warning - refer to accompanying documentation.



Edwards offer European customers a recycling service.

1.2 General

The family of Active vacuum instruments is a new generation of stand-alone units which combine gauge-head and controller in one active unit. The Active Thermocouple Gauge (ATC) consists of an electronics module which is compatible with two types of Thermocouple gauge tubes, the DV4D and DV6M. The module connects to the tube via a standard octal socket. The ATC requires a 13.5 to 36 V d.c. power supply, the pressure reading can be monitored with a simple voltmeter or the analogue to digital converter of a data acquisition system. The type of Gauge tube to be used is selected by a colour-coded two-position switch located in the top of the electronics module. The electronics module also has a potentiometer used to adjust the operating pressure of a setpoint and a LED which indicates the status of the setpoint. The gauge tubes terminate in a 1/8 inch NPT fitting. An adapter to allow connection to NW16 flanges is available from Edwards (refer to spares list). [Figure 1](#) illustrates the main features of the ATC gauge.

This page has been intentionally left blank.

2 Technical data

2.1 Operating conditions

Operating temperature	5 °C to 50 °C
Relative humidity (non-condensing)	10 - 90%
Maximum operating altitude	2000 m

2.2 Performance

2.2.1 Output signal

Voltage range	2 V to 10 V d.c.
Error status	< 2 V or > 10 V d.c.
Minimum load	10 k Ω
Maximum current source	1 mA

2.2.2 setpoint

The setpoint consists of an open drain transistor (FET) output which operates when the gauge pressure is below a preset value. The setpoint has a fixed hysteresis of 1.2 V, that is, if the trip level is set to 4 V, then the trip is set (ON) when the gauge output is below 4 V and reset (OFF) above 5.2 V. When the trip is 'ON' pin 6 is internally connected to pin 2 (power supply common) and the red LED is illuminated.

Settable range	2.2 to 8.5 V
Fixed hysteresis	1.2 V
setpoint output transistor ratings	
Voltage rating	40 V
Current rating	100 mA

Note: The external load must not exceed these ratings.

2.2.3 Gauge identification signal

The gauge identification signal is measured between pins 4 and 5, the readings are dependent upon the position of the gauge select switch.

DV4D	56 k Ω
DV6M	68 k Ω

2.3 Mechanical data

Electronics module	56 mm (height) x 57 mm diameter.
Gauge tube	78 mm (length) x 32 mm diameter.
Assembled length of tube and electronics module	115 mm
Gauge tube volume	DV4D 0.82 cm ³ DV6M 8.2 cm ³
Total weight:	
Electronics module and gauge tube	120 grams
Vacuum connection	1/8 inch NPT

2.4 Electrical data

2.4.1 Electrical supply data

Input voltage range	13.5 V to 36 V d.c.
Maximum voltage ripple	1 V peak to peak
Maximum power consumption (when driven at 36 V d.c. at vacuum)	540 mW

2.4.2 Electronic interface

Socket connection	FCC68, 8 way Western Electric
Pin allocation (See Figure 1 inset)	
1	Power supply positive voltage
2	Power supply common
3	Gauge output signal
4	Gauge identification signal
5	Signal common
6	setpoint output
7	Not connected
8	Not connected

2.5 Thermocouple gauge tubes

Data refers to DV4D and DV6M unless otherwise stated.

2.5.1 Materials exposed to vacuum

Nickel plated steel, alloy 52 (iron nickel) pins, stainless steel, gold, platinum, rhodium and palladium. The DV4D also has a small amount of 60 Tin/40 lead solder.

2.5.2 Colour coding

The gauge tubes are colour-coded on the label and plastic socket moulding as follows:

DV4D	Purple
DV6M	Yellow

2.5.3 Pressure range

When used with ATC electronics module.

DV4D	50 to 5 E-2 torr (65 to 6.5 E-2 mbar)
DV6M	1 to 1E-3 torr (13 - 1.3E-3 mbar)

2.5.4 Thermocouple temperature

All values relative to ambient temperature.

At vacuum	DV4D 250 °C DV6M 300 °C
At atmosphere	DV4D 30 °C DV6M 6 °C

2.5.5 Maximum internal overpressure

DV4D	10.3 bar absolute. (150 psia)
DV6M	3.4 bar absolute. (50 psia)

This page has been intentionally left blank.

3 Installation

3.1 Unpacking and inspection

Remove all packing materials and protective covers and check the gauge for damage. If the gauge is damaged, notify the supplier and the carrier in writing within three days; state the Item Number of the gauge together with the order number and the supplier's invoice number. Retain all packing materials for inspection. Do not use the gauge.

3.2 Connection to the vacuum system

The Thermocouple Gauge tubes terminate in an 1/8 inch NPT fitting. To connect to a tube terminating in a NW16 flange, an 'O' ring, a centring ring (or coseal) and clamp will be required. A tube terminating in a 1/8 inch NPT fitting must be connected to the corresponding female 1/8 inch NPT part. To ensure a leak tight connection wrap a few turns of PTFE tape round the 1/8 inch NPT thread before joining the mating parts. The gauge can be mounted in any orientation, however in order to avoid the build-up of condensable material / liquids in the body tube (causing probable reading errors) a vertical attitude is preferred, that is, the body tube should be vertical with the 1/8 inch NPT fitting below it.

3.3 Positioning the gauges

The gauges should be mounted as close a possible to the point at which the pressure is to be measured. Use a short connecting tube with an internal diameter not less than that of the gauge tube. Long, narrow and angled connections can cause a significant reading error.

3.4 Electrical connection

Figure 2 shows how the gauge should be connected to an external power supply and voltmeter. Refer to Section 2.2 for full specification of the power supply. A voltage between 13.5 - 36 V should be applied between pins 1 and 2 of the connector. Connect the gauge before switching ON. The signal output can be measured between pins 3 and 5. It is important to keep the signal common (Figure 3, item 5) separate from the power supply common (2) for accurate readings. Note that the electronics earth is isolated from the metal thermocouple body tube.

When using a cable longer than 30 m, full compliance with European Standards requires an in-line surge suppressor (please refer to Section 7.2.1).

3.5 Gauge setpoint trip

3.5.1 Adjustment

The setpoint trip is adjusted by a single turn potentiometer accessed through a labelled hole in the top of the electronics module (see Figure 1). The pressure at which the trip operates can be visually set by comparing the position of the arrow on the single turn potentiometer with the adjacent moulded scale. This scale is calibrated in volts, each tick mark representing 1 volt intervals (see Figure 1). The voltage to pressure conversion for the trip level is identical to that of the gauge signal output and is shown in Table 1 and 2.

3.5.2 Trip output

Figure 3 illustrates how the open drain transistor output of the setpoint could be connected to operate an external relay (D) (refer to Key).

Note: The external load must not exceed the ratings specified in Section 2.2.2.

Due to the inductive nature of a relay, a transient voltage can be generated when the relay is switched OFF. The surge rating of the back emf clamping diode must be at least ten times the rated operating current of the relay, that is, a minimum of 1 amp surge rating and have a minimum reverse voltage rating of 100 volts.

Figure 1 - General view of gauge

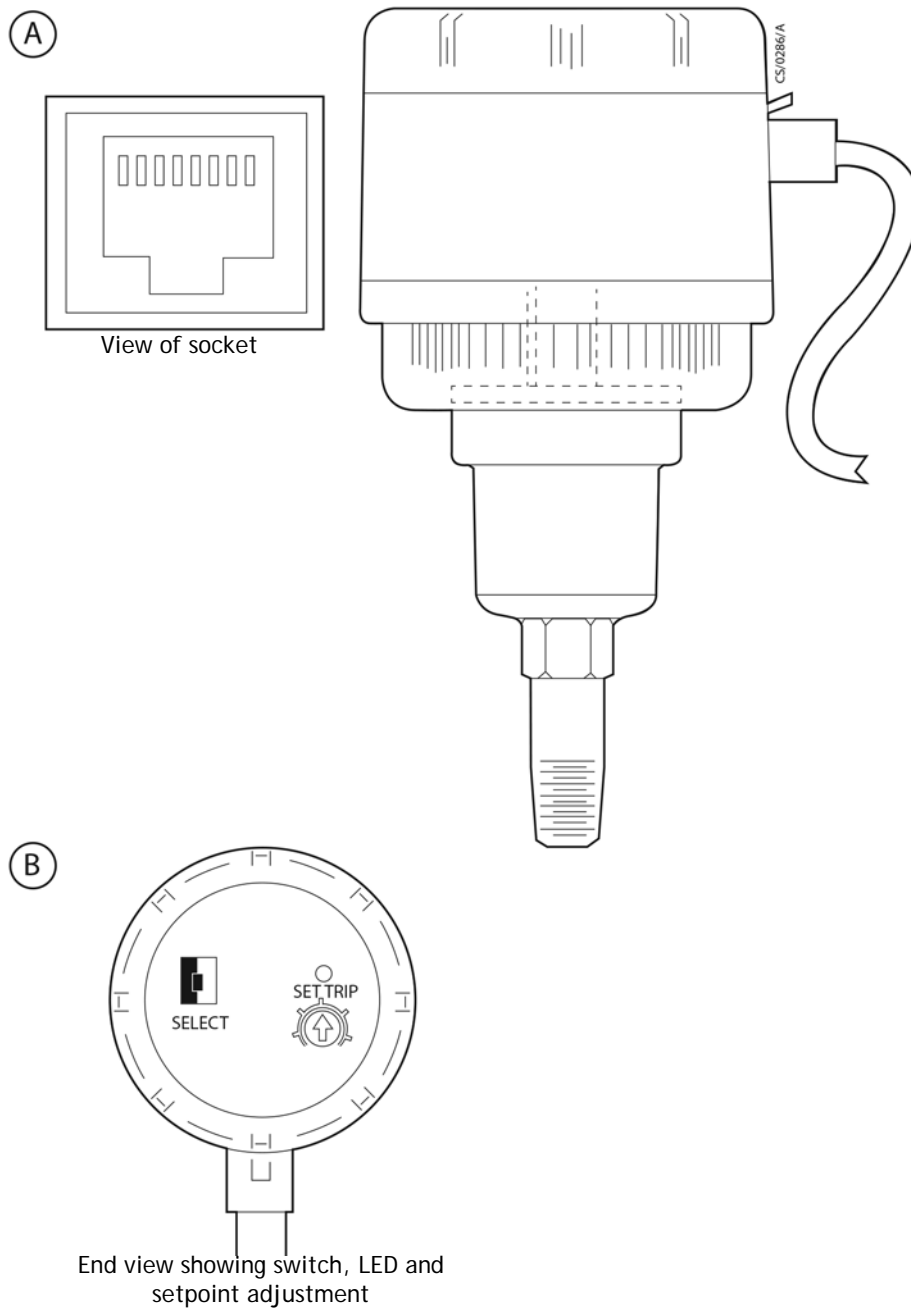
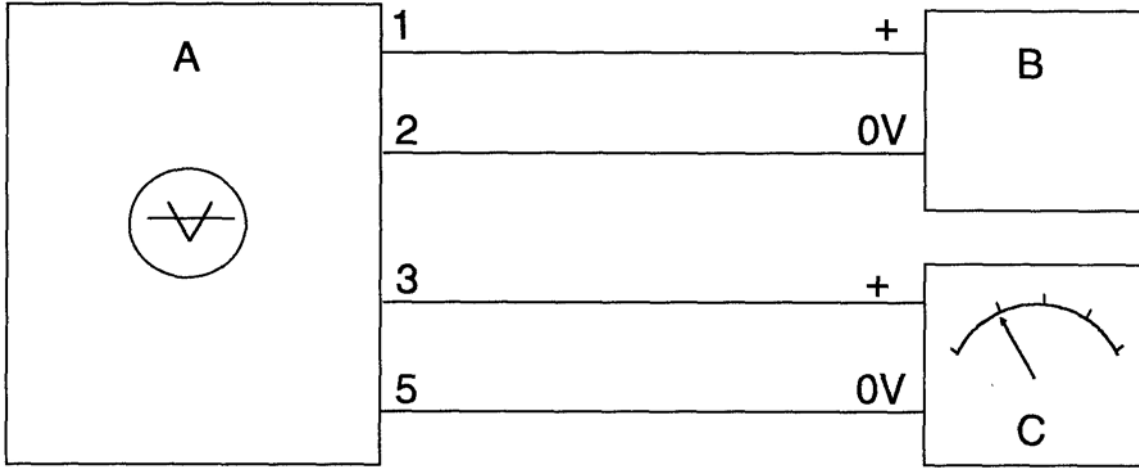
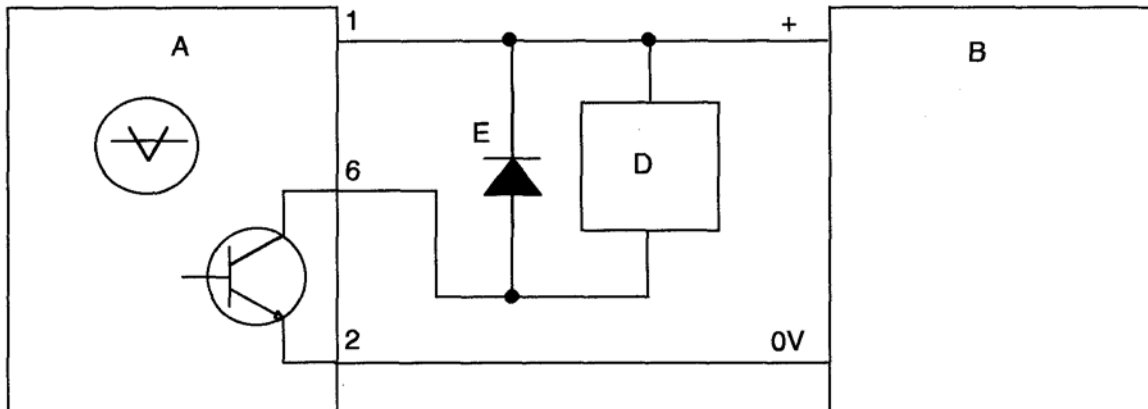

Figure 2 - Connection to external power supply



- A. Active thermocouple gauge
- B. Power supply
- C. Voltmeter or chart recorder
- 1. Positive supply
- 2. Supply common

Figure 3 - Connection of external relay



- A. Active thermocouple gauge
- B. Power supply
- D. External d.c. relay
- E. Back EMF suppressor diode
- 1. Positive supply
- 2. Supply common
- 3. Signal output
- 5. Signal common
- 6. Set-point output

Table 1 - Pressure/voltage characteristic for DV4D

Pressure torr	Output voltage DV4D	Pressure mbar
1.0E-02	2.00	1.3E-02
2.0E-02	2.07	2.6E-02
4.0E-02	2.23	5.3E-02
5.0E-02	2.31	6.6E-02
6.0E-02	2.39	8.0E-02
8.0E-02	2.53	1.1E-01
1.0E-01	2.68	1.3E-01
2.0E-01	3.32	2.6E-01
4.0E-01	4.41	5.3E-01
5.0E-01	4.79	6.6E-01
6.0E-01	5.18	8.0E-01
8.0E-01	5.74	1.1E+00
1.0E+00	6.18	1.3E+00
2.0E+00	7.60	2.6E+00
4.0E+00	8.73	5.3E+00
5.0E+00	8.92	6.6E+00
6.0E+00	9.11	8.0E+00
8.0E+00	9.32	1.1E+01
1.0E+01	9.42	1.3E+01
2.0E+01	9.72	2.6E+01
4.0E+01	9.88	5.3E+01
5.0E+01	9.89	6.6E+01
6.0E+01	9.91	8.0E+01
8.0E+01	9.93	1.1E+02
1.0E+02	9.94	1.3E+02
2.0E+02	9.97	2.6E+02
5.0E+02	9.98	6.6E+02
7.6E+02	10.00	1.0E+03

Table 2 - Pressure/voltage characteristic for DV6M

Pressure torr	Output voltage DV6M	Pressure mbar
1.0E-04	2.00	1.3E-04
5.0E-04	2.19	6.6E-04
1.0E-03	2.25	1.3E-03
2.0E-03	2.38	2.6E-03
4.0E-03	2.62	5.3E-03
6.0E-03	2.84	8.0E-03
8.0E-03	3.06	1.1E-02
1.0E-02	3.27	1.3E-02
2.0E-02	4.16	2.6E-02
4.0E-02	5.56	5.3E-02
5.0E-02	6.01	6.6E-02
6.0E-02	6.46	8.0E-02
8.0E-02	7.04	1.1E-01
1.0E-01	7.42	1.3E-01
2.0E-01	8.59	2.6E-01
4.0E-01	9.40	5.3E-01
5.0E-01	9.50	6.6E-01
6.0E-01	9.60	8.0E-01
8.0E-01	9.71	1.1E+00
1.0E+00	9.76	1.3E+00
2.0E+00	9.89	2.6E+00
4.0E+00	9.96	5.3E+00
5.0E+00	9.97	6.6E+00
1.0E+01	10.00	1.3E+01

4 Operation



WARNING

Do NOT exceed the maximum internal pressure stated in [Section 2](#).



WARNING

Do NOT use the Active Thermocouple gauge to measure the pressure of explosive or flammable gas mixtures.



WARNING

Do NOT operate the Active Thermocouple Gauge in external explosive atmospheres. (No special precautions are made to limit the energy in the gauge electronics to the low levels necessary to make an explosion impossible).



WARNING

An Instrument failure could cause a malfunction of signal outputs. If malfunction of a gauge could cause danger to life or limb, additional safeguards MUST be taken.



WARNING

When measuring gases of high molecular weight the pressure indicated can be well below the true pressure. Ensure that the gauge is not over-pressurised when using heavy gases.

CAUTION

Do not operate Active Thermocouple gauges above an ambient temperature of +50 °C.

4.1 Reading the pressure

The Active Thermocouple gauges have a 2 - 10 V d.c. analog output signal which is a function of pressure. To find the pressure, the output voltage is measured (between pins 3 and 5 on the connector) using a standard voltmeter and compared to the appropriate calibration table. ([Table 1](#) or [2](#)).

4.2 Gas dependency

The rate of heat transfer through a gas is dependent upon both the pressure and the relative molecular mass (RMM) of the gas. Hence the output of signal of the ATC gauge will also be gas dependent. The calibration [Table 1](#) and [2](#) apply to Nitrogen and dry air, but can also be used when measuring the pressure of gases having a similar RMM such as Oxygen and Carbon Monoxide. Generally, with gases having a lower RMM than Nitrogen, the gauge output will read too high, and with high RMM gases the output will read too low. Calibration graphs for use with argon, krypton, helium, carbon dioxide and carbon monoxide are available on request. (Application Note P400-71-000).

This page has been intentionally left blank.

5 Maintenance

5.1 General

There are no user serviceable parts in either the electronics module or the gauge tubes.

5.2 Fault finding

There are three major causes of a fault indication.

- The gauge type is incorrectly selected on the 'SELECT' switch
- The power supply or electronics has failed
- The gauge tube is faulty.

If the gauge output is $< 1.5 \text{ V}$ or $> 10.5 \text{ V}$ it is possible that the electronics module is not correctly connected to the gauge tube, or that the gauge tube is faulty. The user should check for correct connections ([Section 3](#)) and ensure that the power supply voltage is in the range 13.5 - 36 V d.c. positive and that the polarity of the voltmeter is correct with respect to pins 3 and 5, that is, Pin 3 is signal output positive (see [Figure 2](#)). The user should also check the position of the gauge tube selector switch, Yellow for DV6M and Purple for DV4D.

If the gauge output is $> 1.5 \text{ V}$ and $< 2 \text{ V}$ (or > 10 and $< 10.5 \text{ V}$) it could be caused by a difference in gauge tubes, or an indication that the gauge tube is nearing the end of its useful life, due to contamination.

This page has been intentionally left blank.

6 Storage and disposal

6.1 Storage

Store the instrument in a cool dry place.

6.2 Disposal

Dispose of the instrument in accordance with local and national safety requirements.

Alternatively, the instrument and/or cables may be recyclable; contact Edwards or the supplier for advice (also see below).

The instrument and associated cables are within the scope of the European Directive on Waste Electrical and Electronic Equipment. Edwards offers European customers a recycling service for the instrument/cables at the end of the product's life. Contact Edwards for advice on how to return the instrument/cables for recycling.

This page has been intentionally left blank.

7 Accessories

7.1 Introduction

Edwards products, spares and accessories are available from Edwards companies in Belgium, Brazil, China, France, Germany, Israel, Italy, Japan, Korea, Singapore, United Kingdom, U.S.A and a world-wide network of distributors. The majority of these centres employ Service Engineers who have undergone comprehensive Edwards training courses.

Order spare parts and accessories from the nearest Edwards company or distributor. When ordering, please state for each part required:

- Model and Item Number of the equipment
- Serial number (if any)
- Item Number and description of part

7.2 Accessories

The following accessories for the ATC Gauge are available from Edwards.

7.2.1 Cables

Cable length		Code
0.5 m	18 inches	D400-01-005
1 m	3 feet	D400-01-010
3 m	10 feet	D400-01-030
5 m	15 feet	D400-01-050
10 m	30 feet	D400-01-100
15 m	50 feet	D400-01-150
25 m	80 feet	D400-01-250
50 m	150 feet	D400-01-500
100 m	325 feet	D400-01-999
Surge suppressor		D400-06-000

7.3 ATC spares

Description	Code
Electronics module ATC-E-000	D351-08-000
Gauge Tube DV6M	D355-13-000
Gauge Tube DV4D	D355-12-000
1/8 inch NPT to NW16 Adapter	D355-12-050

This page has been intentionally left blank.