

# Instruction Manual

## Active Ion Gauge



Description	Item Number
AIGX-S-NW25	D048-50-000
AIGX-S-DN16CF	D048-51-000
AIGX-S-DN40CF	D048-52-000





# Declaration of Conformity

We, Edwards Limited,  
Crawley Business Quarter,  
Manor Royal,  
Crawley,  
West Sussex, RH10 9LW, UK

declare under our sole responsibility, as manufacturer and person within the EU authorised to assemble the technical file, that the product(s)

Active Ion Gauge	
AIGX-S-NW25	D048-50-000
AIGX-S-DN16CF	D048-51-000
AIGX-S-DN40CF	D048-52-000

to which this declaration relates is in conformity with the following standard(s) or other normative document(s)

EN61010-1: 2010	Safety Requirements for Electrical Equipment for Measurement, Control and Laboratory Use. General Requirements
EN61326-2-3: 2013 (Class B Emissions, Industrial Immunity)	Electrical equipment for measurement, control and laboratory Use. EMC requirements. Particular requirements. Test configuration, operational conditions and performance criteria for transducers with integrated or remote signal conditioning
EN50581:2012	Technical Documentation for the Assessment of Electrical and Electronic Products with respect to the Restriction of Hazardous Substances

and fulfils all the relevant provisions of

2014/30/EU	Electromagnetic Compatibility (EMC) Directive
2011/65/EU	Restriction of Certain Hazardous Substances (RoHS) Directive

*Note: This declaration covers all product serial numbers from the date this Declaration was signed onwards.*

Larry Marini, Senior Technical Manager

09.07.2015, Eastbourne

Date and Place

*This product has been manufactured under a quality management system certified to ISO 9001:2008*

# Contents

Section	Page
<b>1 INTRODUCTION</b> .....	<b>1</b>
1.1 Scope .....	1
1.2 Description .....	1
<b>2 TECHNICAL DATA</b> .....	<b>3</b>
2.1 Mechanical Data .....	3
2.2 Performance, Operating and Storage Conditions .....	3
2.3 Electrical Data .....	3
2.3.1 Electrical Supply .....	3
2.3.2 Output Signal .....	3
2.3.3 Gauge and Degas Enable .....	4
2.3.4 Set-point .....	4
2.3.5 Gauge Identification .....	4
2.3.6 Electrodes .....	4
2.4 Materials Exposed to Vacuum .....	5
<b>3 INSTALLATION</b> .....	<b>7</b>
3.1 Unpack and Inspect .....	7
3.2 Fit the AIGX to the Vacuum System .....	7
3.3 Electrical Connections .....	7
3.3.1 Connect to Edwards Controller .....	7
3.3.2 Connect to Your Own Supply and Control Equipment .....	7
3.3.3 Maximum Cable Length .....	9
<b>4 OPERATION</b> .....	<b>11</b>
4.1 Enable and Disable the AIGX .....	11
4.2 Pressure Measurement .....	11
4.2.1 Calibration in Different Gases .....	12
4.3 Emission Current .....	13
4.4 Degas the AIGX .....	13
4.5 Over-pressure Protection .....	13
4.6 Filament Selection .....	13
4.7 LED Status .....	13
4.8 Set-point Adjustment .....	14
4.9 Error Indication .....	14
4.10 Bakeout .....	14
<b>5 MAINTENANCE</b> .....	<b>17</b>
5.1 Fault Finding Guide .....	17
5.2 Replace the Body Tube .....	17
5.3 Replace the Internal Fuse .....	17
5.4 Calibration Service .....	18
<b>6 STORAGE AND DISPOSAL</b> .....	<b>19</b>
6.1 Storage .....	19
6.2 Disposal .....	19
<b>7 SPARES AND ACCESSORIES</b> .....	<b>21</b>
7.1 Introduction .....	21

7.2	Spares .....	21
7.3	Accessories .....	21
	For return of equipment, complete the HS Forms at the end of this manual.	

## Illustrations

Figure		Page
1	General View of the AIGX (NW25 version) .....	2
2	Dimensions (mm) .....	5
3	Schematic Diagram of Recommended Electrical Connections .....	8
4	Pressure Output Signal of AIGX .....	12
5	Separate the Electronics Housing from the Body Tube .....	15
6	Fuse Replacement .....	18

## Tables

Table		Page
1	Pins On the AIGX Connector .....	9
2	Maximum Recommended Cable Length .....	9
3	Gas Calibration Factors for Various Gases .....	12
4	LED Status .....	13
5	Error Indication .....	14
6	Fault Finding Guide .....	17

## Associated publications

Publication title	Publication number
Vacuum pump and vacuum system safety	P300-20-000

## Trademark credits

Fomblin® is a registered trademark of Ausimont SpA.  
 LET-LOK® is a registered trademark of HAM-LET Group.  
 Swagelok™ is trademark of Crawford Fitting Company.  
 Viton™ is trademark of DuPont Dow Elastomers L.L.C.

# 1 INTRODUCTION

## 1.1 Scope

This manual provides installation, operation and maintenance instructions for the Edwards Active Ion Gauge (AIGX). You must use the AIGX as specified in the manual. Read this manual before installing and operating the AIGX.

Important safety information is highlighted as WARNING and/or CAUTION instructions which must be followed. The use of WARNINGS and/or CAUTIONS is defined below.



### WARNING

Warnings are given where failure to observe the instruction could result in injury or death to people.

### CAUTION

Cautions are given where failure to observe the instruction could result in damage to the equipment, associated equipment and process.

The units used throughout this manual conform to SI international system of measurement followed by imperial units in parenthesis; SI (imperial).

In accordance with the recommendations of IEC1010, the following warning symbols are on the pump:



Warning - refer to accompanying documentation.



From August 2005, Edwards will offer European customers a recycling service.

## 1.2 Description

The AIGX is an ion gauge head and gauge controller in a single compact unit. The gauge operates as a hot filament ionisation gauge, in which the pressure is measured indirectly as a function of the current.

The measurement range of the AIGX is  $5 \times 10^{-10}$  to  $5 \times 10^{-2}$  torr ( $6.6 \times 10^{-10}$  to  $6.6 \times 10^{-2}$  mbar). Three types of vacuum connections are available: DN16CF, DN40CF and NW25.

The AIGX requires a 14.5 - 30 V d.c. power supply; it has a 0 to 10 V d.c. analogue output which is related to pressure. The AIGX is compatible with Edwards Controllers. Alternatively, you can use an independent power supply and you can read the output signal with a voltmeter or analogue to digital converter.

An 8-way electrical connector socket on the AIGX (Figure 1, item 1) is used to connect the AIGX to your Controller or electrical supply and voltmeter. Electrical cables fitted with suitable connectors are available as accessories. A gauge identification signal is available on the electrical connector: this signal is used by Edwards Controllers to identify which type of active gauge is connected.

The AIGX is supplied with two filaments. A switch on top of the gauge selects between filament 1 and 2 (Figure 1, item 2).

There are two levels of emission currents: 0.1 and 1 mA. The gauge will automatically select 1 mA emission current at low pressure, and 0.1 mA at high pressure.

A protection circuit is built into the gauge to prevent operating the gauge at pressures higher than  $5 \times 10^{-2}$  torr.

The AIGX can be degassed using the degas feature. During degas, the grid voltage is 500 V and the emission current is 10 mA. The degas is inhibited at high pressure. The maximum duration of degas is three minutes, after which the gauge returns automatically to its normal mode.

The AIGX has a set-point facility. The set-point signal is an open collector transistor output, which is on when the pressure measured by the gauge is below a preset pressure. The pressure at which the set-point operates can be adjusted using the set-trip switch on the top of the gauge (1, item 3).

The AIGX is fitted with a status LED (Figure 1, item 4). This LED indicates the operating status of the gauge.

Figure 1 - General View of the AIGX (NW25 version)

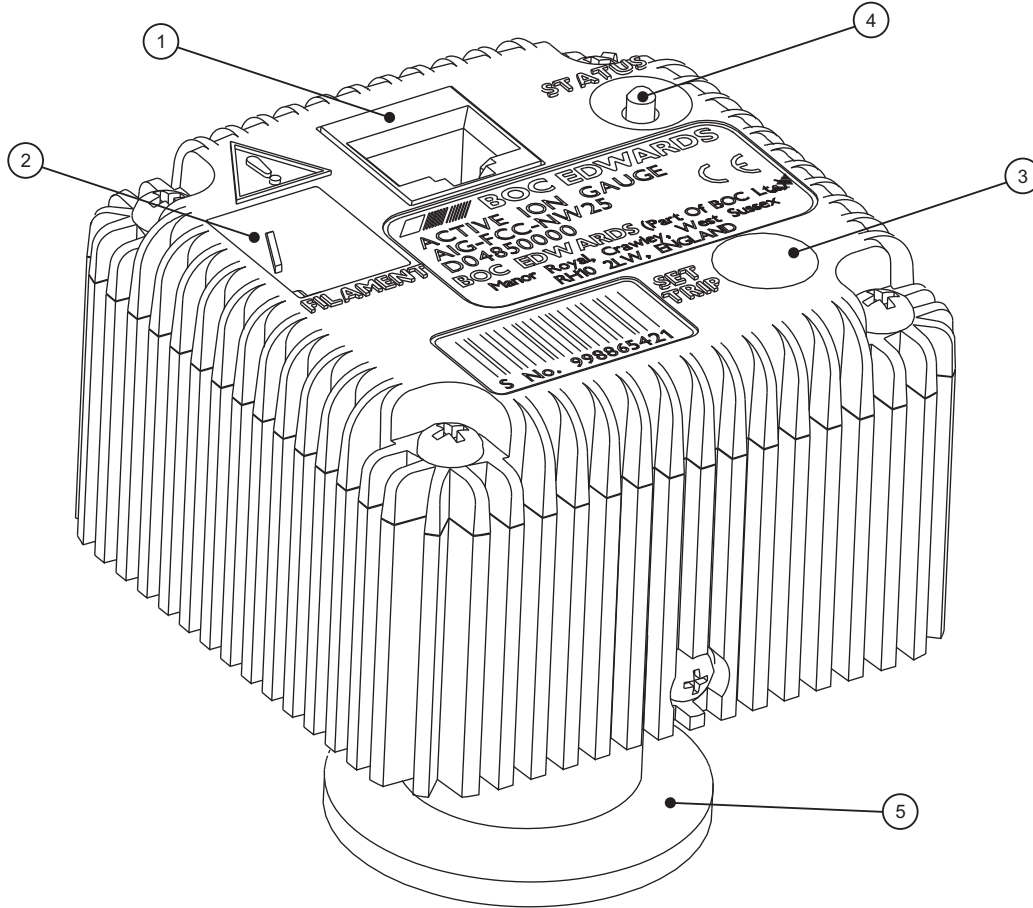

- 1. Electrical connector
- 2. Filament select switch
- 3. Set trip switch
- 4. Status LED
- 5. Vacuum flange

## 2 TECHNICAL DATA

### 2.1 Mechanical Data

Dimensions	See Figure 2
Mass	
2AIGX-S-NW25260 g	260 g
AIGX-S-DN16CF300 g	300 g
AIGX-S-DN40CF510 g	510 g
Volume of gauge tube	21 cm <sup>3</sup>
Enclosure rating	IP30

### 2.2 Performance, Operating and Storage Conditions

Ambient temperature	
Operation	0 to 40 °C
Storage	-30 to 70 °C
Ambient humidity	90% RH (non-condensing) up to 31 °C reducing to 50 % RH at 40 °C
Atmosphere	Dry non-conductive only (pollution degree 1)
Bakeout temperature	200 °C (with electronics removed)
Maximum operating altitude	2000 m
Maximum internal pressure	10 bar absolute
Pressure measurement range	5 x 10 <sup>-10</sup> to 5 x 10 <sup>-2</sup> torr (6.6 x 10 <sup>-10</sup> to 6.6 x 10 <sup>-2</sup> mbar)

### 2.3 Electrical Data

#### 2.3.1 Electrical Supply

Voltage	+14.5 V to +30 V d.c.
Internal fuse	1 A (T)
Maximum power consumption	
Operating	7 W
Degas	14 W
Electrical connector	FCC 68 (RJ45)

#### 2.3.2 Output Signal

Measurement range	0.7 V to 8.7 V
Gauge disabled	9.0 V
Emission error	9.5 V
Over-pressure trip	9.7 V
Minimum load impedance	10 kW

### 2.3.3 Gauge and Degas Enable

Control sense	Active low
Active level	< 1.5 V

### 2.3.4 Set-point

Trip level	0.6 V to 8.8 V
Hysteresis	500 mV
Set-point output load rating	30 V d.c., 100 mA max
Back EMF suppression diode *	
Min surge rating	1 A
Min reverse voltage rating	100 V

\* required when you use an external d.c. relay connected to the set-point output

### 2.3.5 Gauge Identification

Identification resistance	162 k $\Omega$
---------------------------	----------------

### 2.3.6 Electrodes

Emission current	
Normal	0.1 or 1 mA
Degas	10 mA
Grid voltage	
Normal	180 V
Degas	500 V
Filament bias voltage	+ 30 V
Collector voltage	0 V



## 2.4 Materials Exposed to Vacuum

Collector	Tungsten
Grid	Tantalum Pt Clad Mo
Filament	Yttria coated iridium
Body	Stainless Steel
Feedthrough	Stainless Steel and UHV compatible, glass/ceramic

Figure 2 - Dimensions (mm)

	Dim A
NW25	85 mm
DN16CF	106 mm
DN40CF	98 mm

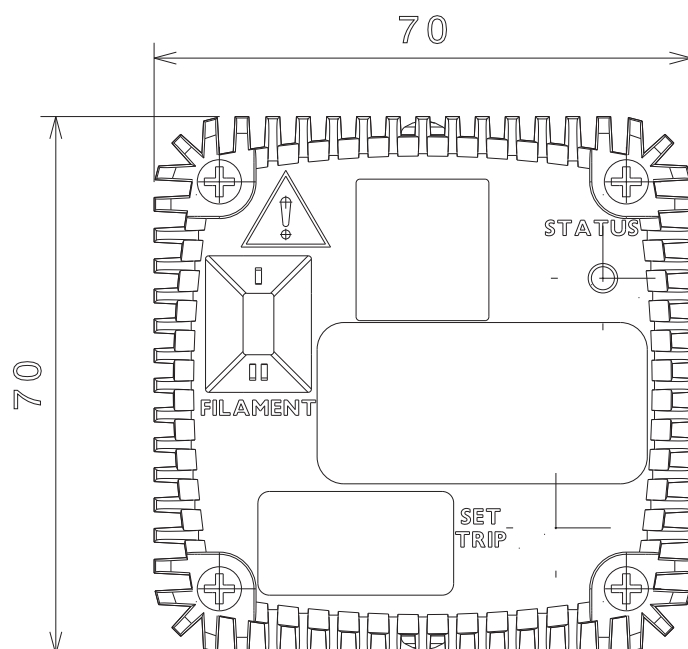
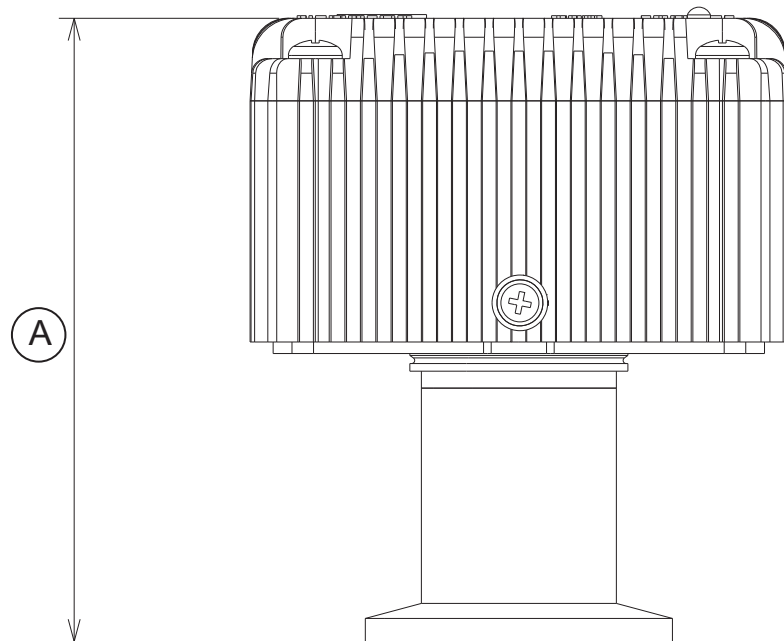

This page has been intentionally left blank.

## 3 INSTALLATION

### 3.1 Unpack and Inspect

Remove all packing materials and protective covers and check the AIGX .

If the AIGX is damaged, notify your supplier and the carrier in writing within three days; state the Item Number of the gauge together with your order number and your supplier's invoice number. Retain all packing materials for inspection. Do not use the AIGX if it is damaged.

If the AIGX is not to be used immediately, replace the protective covers. Store the AIGX in suitable conditions as described in Section 6.

### 3.2 Fit the AIGX to the Vacuum System

The AIGX can be mounted in any orientation. To avoid the build-up of debris or condensable material in the body tube of the AIGX (which will probably cause pressure measurement errors), we recommend that you install the AIGX vertically with the flange facing down.

Use a copper gasket and screws to connect the DN16CF and DN40CF flanges of the AIGX to a similar flange on your vacuum system. Use an 'O' ring /centring-ring or Co-Seal and metal clamp to connect the NW25 flange of the AIGX to a similar flange on your vacuum system.

**Note:** 'O' rings are not recommended for systems where UHV pressures are required.

### 3.3 Electrical Connections



#### WARNING

The AIGX must be connected to an earthed (grounded) vacuum system. For gauges with a NW25 flange, a conductive metallic clamping ring must be used.



#### WARNING

If the AIGX malfunctions, the AIGX pressure output may be incorrect. If such a failure could result in damage to equipment or cause injury to people, you must install a suitable control system to indicate the failure and, if necessary, to close down your process system.

#### 3.3.1 Connect to Edwards Controller

Connect the AIGX to the Controller using a cable which is terminated in suitable connectors. Suitable cables are available from Edwards. Refer to Section 7.3.

**Note:** Your Controller must have a version of software that is compatible with the AIGX. If the Controller display shows ??? when the AIGX is plugged in, then an upgrade to the Controller software is required. Please contact Edwards.

**Note:** For cable lengths exceeding 10 m, cables with a larger conductor cross-section are required.

#### 3.3.2 Connect to Your Own Supply and Control Equipment

**Note:** Do not connect the electrical supply common (pin 2) to the signal common (pin 5). If you do, the AIGX pressure output signal will be inaccurate.

A schematic diagram of the recommended electrical connections to the AIGX is shown in Figure 3.

Figure 3 - Schematic Diagram of Recommended Electrical Connections

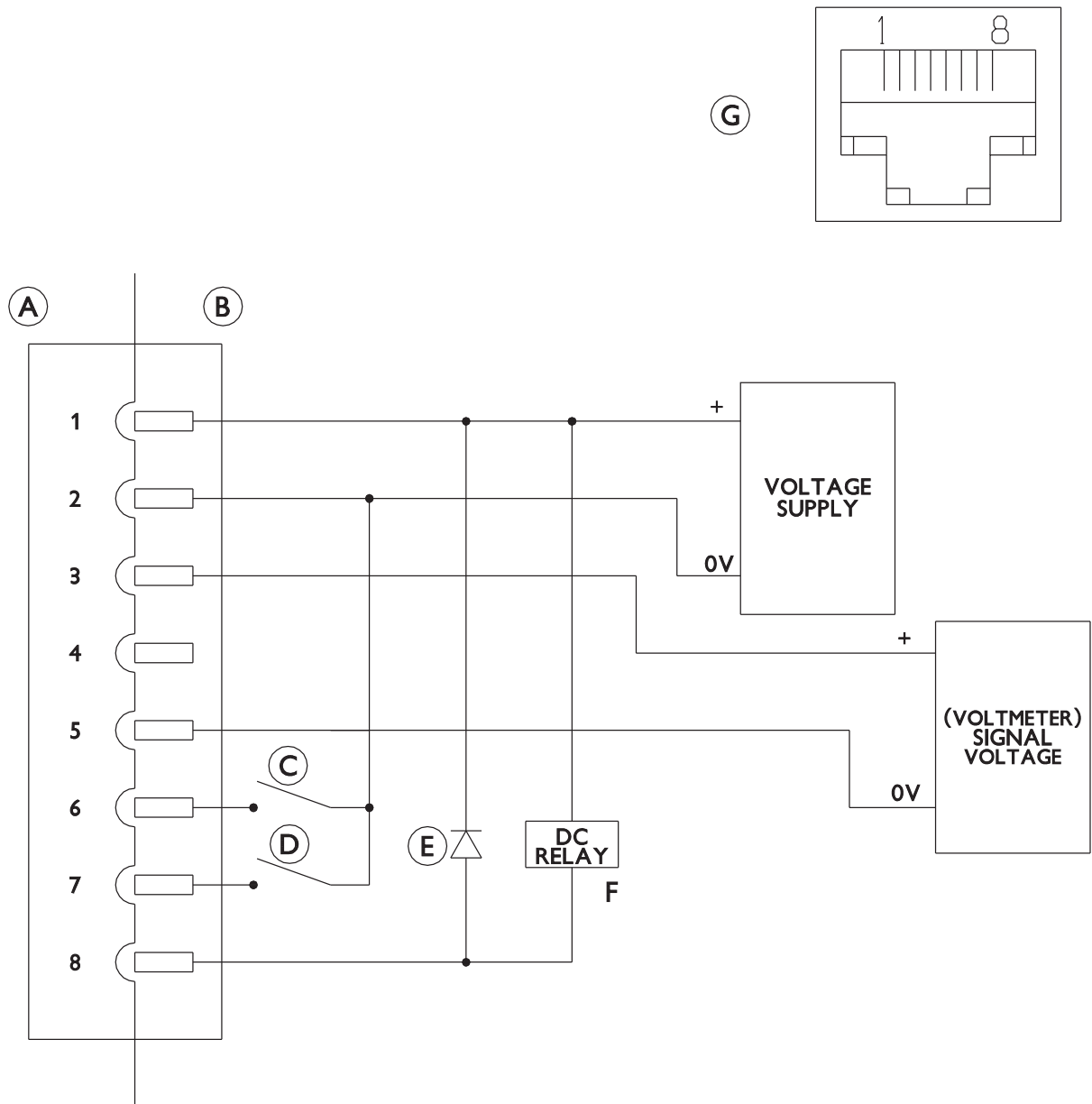

Connect a switch between pins 7 and 2 to enable and disable the gauge.

Connect a switch between pin 6 and 2 to enable and disable the degas function.

- A. AIGX connector (socket)
- B. Cable electrical (plug)
- C. Degas enable switch
- D. Gauge enable switch
- E. Back EMF suppression diode (optional)
- F. D.C. relay (optional)
- G. View of AIGX connector

The pins on the AIGX connector are used as shown in Table 1. The specification of the electrical supply, d.c. relay and back EMF suppression diode are given in Section 2.

**Table 1 - Pins On the AIGX Connector**

Pin No.	Use
1	Supply positive
2	Supply common
3	Signal output
4	ID resistor
5	Signal common
6	Degas enable
7	Gauge enable
9	Set-point output

The connection to Pin 8 is optional. Make the connection to Pin 8 if you want to connect the set-point output signal to a d.c. relay. You must connect a suppression diode between pins 8 and 1 to protect the AIGX from transient voltage generated when the d.c. relay is switched off.

### 3.3.3 Maximum Cable Length

The maximum cable length is dependent on the conductor cross-section and the supply voltage used. The following maximum cable lengths are recommended:

**Table 2 - Maximum Recommended Cable Length**

Conductor Cross-Section	24 V Supply	15 V Supply
24 awg	30 m	0.5 m
28 awg	10 m	1 m

The common mode signal voltage (that is, the voltage between signal common and supply common) could be as much as 2.5 V with long cables due to the voltage drop in the supply cable. You should ensure that the signal voltage measurement will operate correctly.

This page has been intentionally left blank.

## 4 OPERATION



### WARNING

Do not use the AIGX to measure the pressure of explosive or flammable gases or mixtures.



### WARNING

During operation, the surface of the ion gauge tube might become hot. To avoid risk of injury, do not touch the tube whilst the gauge is operating. Switch off the gauge and allow to cool down for few minutes before handling.



### WARNING

Disconnect the electrical supply cable from the AIGX before you remove the AIGX from the vacuum system. High voltages are generated inside the AIGX.

### 4.1 Enable and Disable the AIGX

#### CAUTION

The gauge should not be operated at pressures higher than  $5 \times 10^{-2}$  torr ( $6.6 \times 10^{-2}$  mbar). Operating the AIGX at high pressures may reduce the lifetime of the filament.

If you are using the AIGX with a Controller, refer to the Controller instruction manual for details of how to enable the AIGX. Alternatively, to enable (switch on) the AIGX, connect pin 7 to pin 2. To disable (switch off) the AIGX, disconnect pin 7 from pin 2.

When the AIGX is enabled, the output signal will remain at 9.0 V whilst the emission current is being stabilised. This will take typically 5 seconds (may be longer at lower pressures). After this time the output signal will indicate pressure. If an error occurs, then the output signal will indicate the error.

### 4.2 Pressure Measurement

If you are using an AIGX with a Controller, the pressure measurement is shown on the Controller display. Otherwise, convert the output signal to pressure using the following equation:

$$P = 10^{(V - 10)} \text{ torr}$$

$$P = 10^{(V - 9.875)} \text{ mbar}$$

$$P = 10^{(V - 7.875)} \text{ Pa}$$

where V is the measured voltage in volts. Refer to [Figure 4](#). This formula is valid for the range 0.7 V to 8.7 V.

Figure 4 - Pressure Output Signal of AIGX

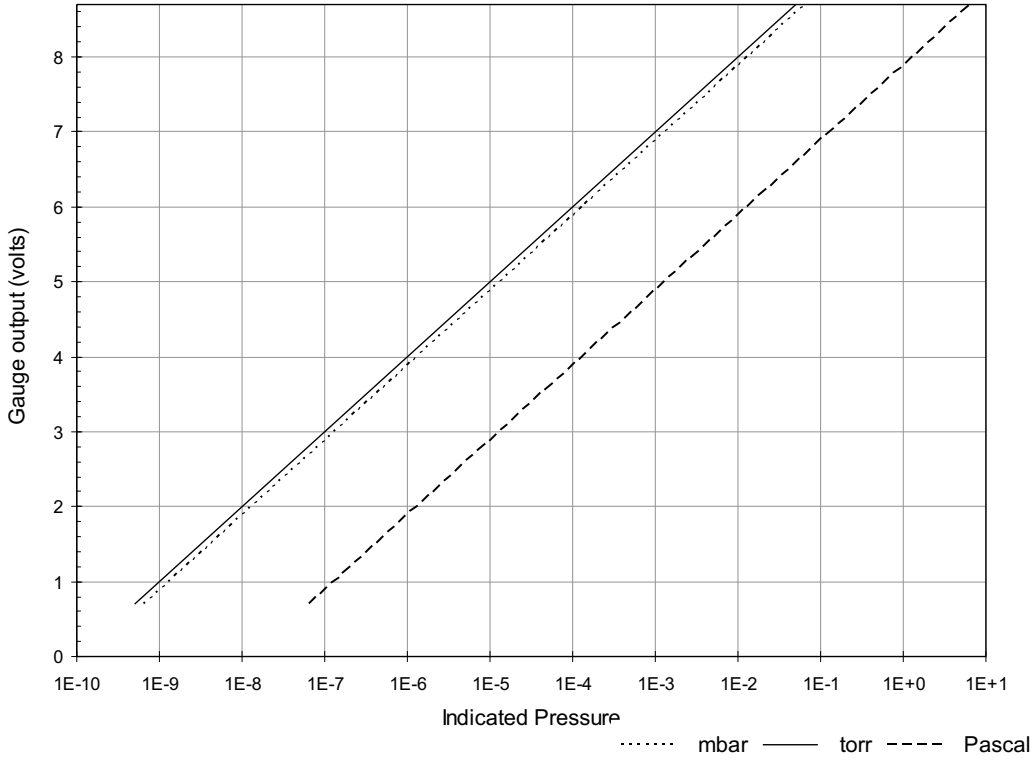

### 4.2.1 Calibration in Different Gases

The equation given in Section 4.2 is for air or nitrogen only. For other gases, the indicated pressure has to be multiplied by a gas calibration factor (GCF).

The following table lists the gas calibration factor for most commonly used gases.

Table 3 - Gas Calibration Factors for Various Gases

Gas	GCF
Helium	5.7
Argon	0.75
Neon	3.3
Krypton	0.5
Xenon	0.35
Hydrogen	2.4
Oxygen	1
Carbon Monoxide	1.15
Carbon Dioxide	0.7



### 4.3 Emission Current

To increase the life time of the filament, the two levels of emission currents are automatically controlled by the gauge. As the pressure goes down, the emission current changes from 0.1 mA to 1mA at  $2 \times 10^{-5}$  torr ( $2.6 \times 10^{-5}$  mbar). As the pressure goes up, the emission current changes from 1 mA to 0.1 mA at  $5 \times 10^{-5}$  torr ( $6.6 \times 10^{-5}$  mbar).

### 4.4 Degas the AIGX

---

#### CAUTION

**You must degas the AIGX regularly. Failure to do so will affect the performance and reduce the lifetime of the gauge.**

---

During use in contaminating environments the gauge electrodes become coated in insulating layers, eventually resulting in premature failure of the product. This can be prevented by regular use of the degas feature. Typically, degas will be required on a weekly basis although the interval will depend on the level of contamination.

The degas operation is also recommended if measurement of low pressure are required.

During degas, the grid will be heated to high temperature, sufficient to remove absorbed gases and some contamination.

Degas the AIGX when the pressure is below  $1 \times 10^{-5}$  torr ( $1.3 \times 10^{-5}$  mbar). The degas is inhibited when the pressure is above  $1 \times 10^{-4}$  torr ( $1.3 \times 10^{-4}$  mbar). The gauge will automatically return to the normal operation mode after 3 minutes.

If you are using the AIGX with a Controller, refer to the Controller instruction manual for details of how to degas the AIGX. Otherwise, to enable degassing of the AIGX, connect pin 6 to pin 2.

### 4.5 Over-pressure Protection

The gauge will automatically switch off when the measured pressure rises above  $5 \times 10^{-2}$  torr ( $6.6 \times 10^{-2}$  mbar). If this occurs then the signal output and LED status will indicate over-pressure trip. Refer to [Section 4.9](#).

### 4.6 Filament Selection

The AIGX has two filaments, 1 and 2. To select either of these filaments, use the sliding switch at the top of the gauge. Make sure that the gauge is turned off before switching between filaments.

### 4.7 LED Status

The AIGX is fitted with a tri-coloured LED which can be used to monitor the status of the gauge according to the following table:

Table 4 - LED Status

Colour	Status
Off	No power to the gauge or malfunction
Amber	Power on, gauge disabled
Green/Amber (alternating)	Emissions start-up
Green	Emission on
Green (slow flashing)	Degas on
Red (flashing)	Emission error
Red	Over-pressure trip

### 4.8 Set-point Adjustment

To read the voltage at which the set-point output signals are activated, press the required set trip switch (refer to Figure 1) with an appropriate tool. The output of the gauge will indicate the set trip level for 3 seconds after which the output will read the normal voltage output.

To adjust the voltage at which the set-point output signal is activated, press the required set trip switch and hold it down for more than 3 seconds. The set-point voltage will start scrolling upwards. Remove pressure from the switch as soon as you reach the required trip voltage. To make a finer adjustment, remove pressure from the set trip switch and immediately depress the switch as many times as required. Each depression will increase the set trip voltage by approximately 10 mV. Refer to Section 4.2 to determine the operating voltage which corresponds to a given pressure.

If required, the set-point signal can be used to indicate when the gauge is operating correctly. Adjust the set-point trip level to > 8.8 V. The set-point output will then be ON when the AIGX is operating normally. The set-point output will be OFF if the gauge is disabled or if an error condition is detected.

### 4.9 Error Indication

If an error occurs during operation of the AIGX, then the output signal and the LED will indicate the error. Refer to Section 5.1 for a fault finding guide.

Table 5 - Error Indication

Error Condition	Output Signal	LED	AGC Display
Emission error	9.5 V	Red Flashing	EM ERR
Over-pressure trip	9.7 V	Red	OVER R

If an error is indicated then the AIGX will automatically turn off. You should disable the AIGX to remove the error indication, and correct the error. You may then re-enable the AIGX if required.

**Note:** *If you are using the AIGX with an AGC, then the AGC will display an error message and disable the AIGX when an error occurs. In this case the LED status will return to OFF, and you should view the AGC display to determine the error.*

### 4.10 Bakeout

The AIGX tube can be baked to temperatures up to 200 °C after removing the electronics housing. Refer to Figure 5 and the procedure in Section 5.2 to remove and refit the electronics housing.

Ensure that the tube has cooled down before refitting the electronics housing.

Figure 5 - Separate the Electronics Housing from the Body Tube

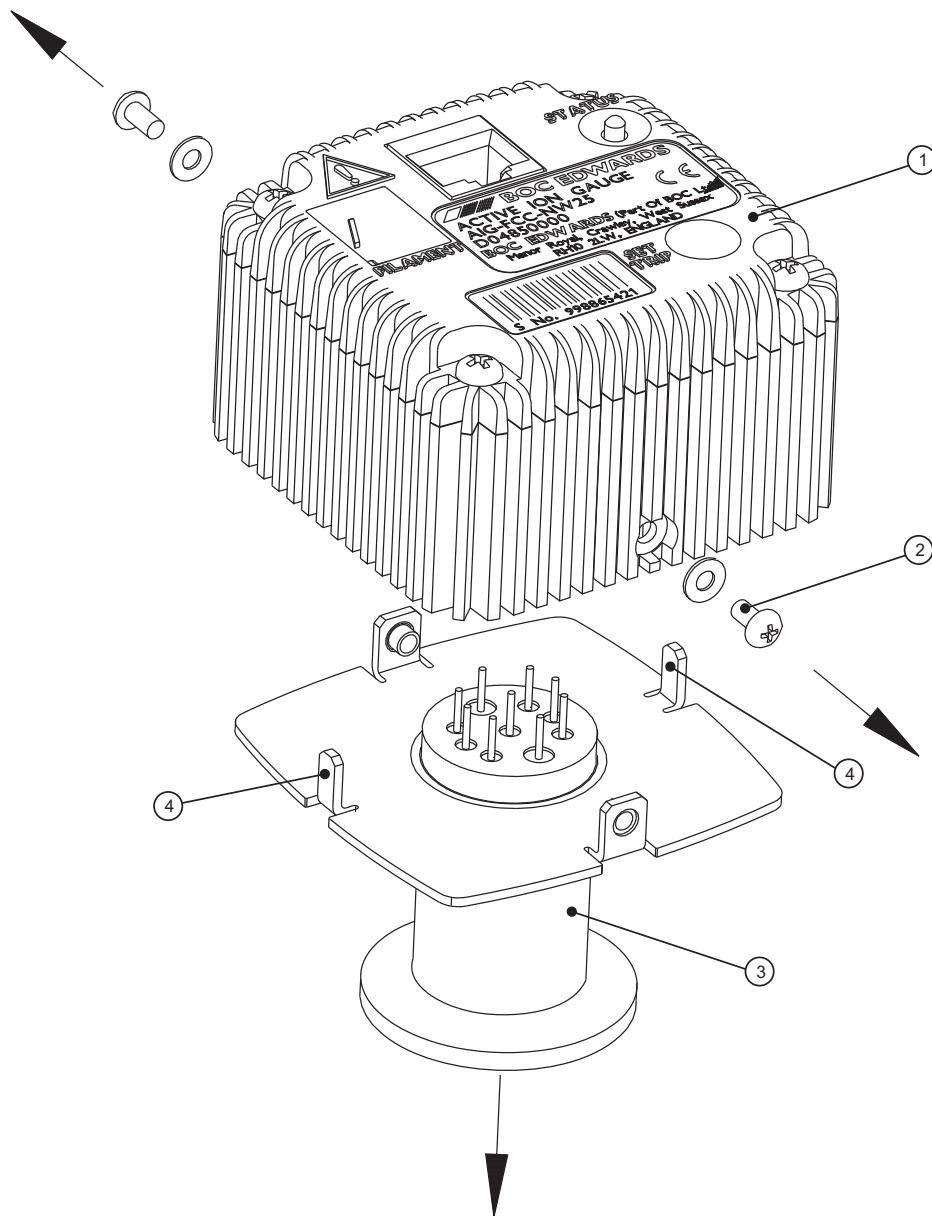

1. Electronics housing
2. Fixing screws
3. Body tube assembly
4. Locating lugs

This page has been intentionally left blank.

## 5 MAINTENANCE



### WARNING

Disconnect the electrical supply cable before you start any maintenance. High voltages are generated inside the AIGX.

### 5.1 Fault Finding Guide

Table 6 - Fault Finding Guide

Symptom	Possible Cause	Remedy
LED Not Lit	Supply connection incorrect or faulty. Supply polarity reversed.	Check electrical supply and connections.
	Internal fuse blown.	Replace fuse. Refer to Section 5.3
Over-pressure trip	The pressure rose too high whilst the AIGX was operating.	Reduce the pressure and re-enable the AIGX.
Emission error	The AIGX was enabled when the pressure was too high.	Reduce the pressure and re-enable the AIGX.
	Filament contaminated. Filament open circuit.	Switch to the other filament. If both filaments give the error, replace the body tube. Refer to SSection 5.2.
	Electrical supply insufficient to drive the AIGX.	Check that supply voltage/current specifications meet requirement in Section 2.3.1.

### 5.2 Replace the Body Tube

Refer to Figure 5 and use the following procedure to replace the body tube.

1. Turn off the gauge.
2. Switch off the AIGX electrical supply and disconnect the electrical supply cable.
3. Remove the AIGX from the vacuum system.
4. Using a suitable screwdriver, remove the two M3 screws (item 2) from the sides of the electronics housing (item 1).
5. Pull the electronics housing (item 1) to remove it from the body tube assembly (item 3).
6. Fit the new body tube assembly (item 3) to the electronics housing (item 1). Take care to ensure that the locating lugs (item 4) on the body tube assembly (item 3) are aligned with the mating recess in the electronics housing (item 1). Note that the electronics housing (item 1) can only fit one way round on the body tube assembly (item 3).
7. Refit the two M3 screws to the sides of the AIGX.

### 5.3 Replace the Internal Fuse

If you suspect that the internal fuse has blown, you should check that the voltage and polarity of the electrical supply are correct before replacing the fuse.

To replace the fuse refer to Figure 6 and use the following procedure:

1. Switch off the electrical supply and remove the electrical supply connector from the gauge.
2. Using a suitable screwdriver, remove the four M3.5 screws from the top of the gauge.
3. Remove the gauge lid, ensuring the pin on the underside of the lid is not bent.
4. The fuse will now be visible on the PCB. Hold the board down and then pull the fuse from its fuseholder using an appropriate tool (for example, a small pair of pliers).
5. The replacement fuse is supplied mounted in a fuseholder. Remove the new fuse from its fuseholder and discard the new fuseholder.
6. Push the new fuse into the fuseholder on the PCB.
7. Refit the gauge lid ensuring that the pin is fitted in the shrouded earth socket next to the main connector. Refit the four M3.5 screws.
8. Apply power to the gauge and check that the LED is illuminated.

Replacement fuses are available from Edwards. Refer to [Section 7.2](#).

## 5.4 Calibration Service

A calibration service is available for all Edwards gauges. Calibration is by comparison with reference gauges, traceable to National Standards. Contact Edwards for details.

**Figure 6 - Fuse Replacement**

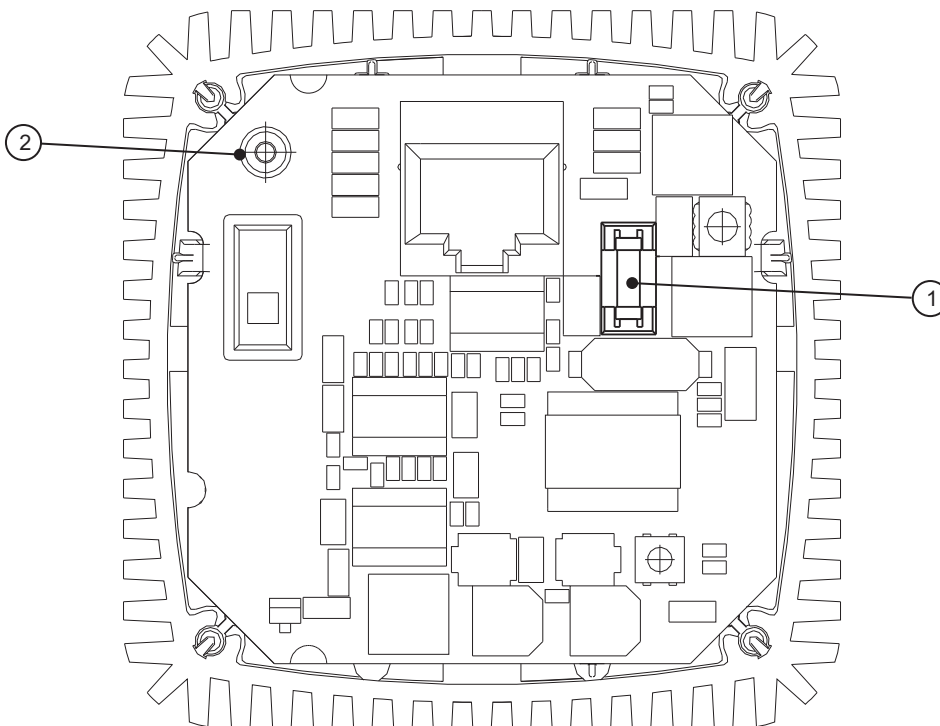

1. Fuse holder
2. Shrouded earth socket

## 6 STORAGE AND DISPOSAL

### 6.1 Storage

Return the AIGX to its protective packaging and store the AIGX in clean dry conditions until required for use. Do not exceed the storage temperature conditions specified in [Section 2](#).

When required for use, prepare and install the AIGX as described in [Section 3](#).

### 6.2 Disposal

Disposal of the AIGX in accordance with all local and national safety and environmental requirements.

Alternatively, you may be able to recycle the AIGX and/or cables; contact Edwards or your supplier for advice (also see below).

The AIGX and associated cables are within the scope of the European Directive on Waste Electrical and Electronic Equipment, 2002/96/EC. From August 2005, Edwards will offer European customers a recycling service for the AIGX/cables at the end of the product's life. Contact Edwards for advice on how to return the AIGX/cables for recycling.

This page has been intentionally left blank.



## 7 SPARES AND ACCESSORIES

### 7.1 Introduction

Edwards products, spares and accessories are available from Edwards companies in Belgium, Brazil, Canada, France, Germany, Hong Kong, Italy, Japan, Korea, Switzerland, United Kingdom, USA, and a worldwide network of distributors. The majority of these centers employ Service Engineers who have undergone comprehensive Edwards training courses.

Order spare parts and accessories from the nearest Edwards company or distributor. When ordering, provide the following information:

- Model and Item Number of equipment.
- Serial number.
- Item Spares

Refer to the Parts manual.

### 7.2 Spares

The following is a list of accessories that can be purchased by contacting Edwards.

Description	Item Number
Electronics housing	
AIGX-S	D048-50-800
Body tubes	
NW25	D048-50-801
DN16CF	D048-51-801
DN40CF	D048-52-801
Spare fuses (pack of 5)	D048-50-805

### 7.3 Accessories

Cables suitable for use with the AIGX are as follows. These cables are supplied with 8-way male electrical connectors on both ends. Note that the 15 m and 30 m cables have a larger conductor cross-section.

Cable length	Item Number
0.5 m	D400-01-005
1 m	D400-01-010
3 m	D400-01-030
5 m	D400-01-050
10 m	D400-01-100
15 m	D400-05-150
30 m	D400-05-300

SPARES AND ACCESSORIES

Description	Item Number
Annealed copper gasket - DN16CF	C100-01-270
Hex head nut, bolt and washer kit - DN16CF	C100-01-630
Annealed copper gasket - DN40CF	C100-05-270
Hex head nut, bolt and washer kit - DN40CF	C100-05-630