

Instruction Manual

Active Ion Gauge



Description	Item Number
AIGX - D - NW25	D048-60-000
AIGX - D - DN16CF	D048-61-000
AIGX - D - DN40CF	D048-02-000





Declaration of Conformity

We, Edwards Limited,
Crawley Business Quarter,
Manor Royal,
Crawley,
West Sussex, RH10 9LW, UK

declare under our sole responsibility, as manufacturer and person within the EU authorised to assemble the technical file, that the product(s)

Active Ion Gauge	
AIGX-D-NW25	D048-60-000
AIGX-D-DN16CF	D048-61-000
AIGX-D-DN40CF	D048-62-000

to which this declaration relates is in conformity with the following standard(s) or other normative document(s)

EN61010-1: 2010	Safety Requirements for Electrical Equipment for Measurement, Control and Laboratory Use. General Requirements
EN61326-2-3: 2013 (Class B Emissions, Industrial Immunity)	Electrical equipment for measurement, control and laboratory Use. EMC requirements. Particular requirements. Test configuration, operational conditions and performance criteria for transducers with integrated or remote signal conditioning
EN50581:2012	Technical Documentation for the Assessment of Electrical and Electronic Products with respect to the Restriction of Hazardous Substances

and fulfils all the relevant provisions of

2014/30/EU	Electromagnetic Compatibility (EMC) Directive
2011/65/EU	Restriction of Certain Hazardous Substances (RoHS) Directive

Note: This declaration covers all product serial numbers from the date this Declaration was signed onwards.

Larry Marini, Senior Technical Manager

09.07.2015, Eastbourne

Date and Place

This product has been manufactured under a quality management system certified to ISO 9001:2008

Contents

Section	Page
1	Introduction 1
1.1	Scope and definitions 1
1.2	Description 1
2	Technical Data 3
2.1	Mechanical data 3
2.2	Performance, operating and storage conditions 3
2.3	Electrical data 3
2.3.1	Electrical supply 3
2.3.2	Output signal 4
2.3.3	Gauge and degas enable 4
2.3.4	Status outputs 4
2.3.5	Electrodes 4
2.4	Materials exposed to vacuum 4
3	Installation 7
3.1	Unpack and inspect 7
3.2	Fit the AIGX to the vacuum system 7
3.3	Electrical connections 7
3.3.1	Connect to your own supply and control equipment 7
3.3.2	Maximum cable length 9
4	Operation 11
4.1	Enable and disable the AIGX 11
4.2	Pressure measurement 11
4.2.1	Calibration in different gases 11
4.3	Emission current selection 12
4.4	Degas the AIGX 13
4.5	Over-pressure protection 13
4.6	Filament selection 13
4.7	LED status 13
4.8	Bakeout 14
5	Maintenance 15
5.1	Fault finding guide 15
5.2	Replace the body tube 15
5.3	Replace the internal fuse 15
5.4	Calibration service 16
6	Storage and Disposal 17
6.1	Storage 17
6.2	Disposal 17
7	Spares and Accessories 19
7.1	Introduction 19
7.2	Spares 19
7.3	Accessories 19
	For return of equipment, complete the HS Forms at the end of this manual.

Illustrations

Figure		Page
1	General View of the AIGX	2
2	Dimensions	5
3	Schematic Diagram of Recommended Electrical Connections	8
4	Pressure Output Signal of AIGX	12
5	Separate the Electronics Housing from the Body Tube	14
6	Fuse Replacement	16

Tables

Table		Page
1	Pins on the AIGX Connector	8
2	Maximum Recommended Cable Length	9
3	Gas Calibration Factors For Various Gases	12
4	LED Status	13
5	Fault Finding Guide	15

Associated publications

Publication title	Publication number
Vacuum pump and vacuum system safety	P300-20-000

1 Introduction

1.1 Scope and definitions

This manual provides installation, operation and maintenance instructions for the Edwards Active Ion Gauge (AIGX). You must use the AIGX as specified in the manual.

Read this manual before you install and operate the AIGX. Important safety information is highlighted as WARNING and CAUTION instructions; you must obey these instructions. The use of WARNINGS and CAUTIONS is defined below.



WARNING

Warnings are given where failure to observe the instruction could result in injury or death to people.

CAUTION

Cautions are given where failure to observe the instruction could result in damage to the equipment, associated equipment and process

The following IEC warning labels appear on the pump:



Warning - refer to accompanying documentation.



Warning - Edwards offer European customers a recycling service.

The units used throughout this manual conform to the SI international system of units of measurement.

1.2 Description

The AIGX is an ion gauge head and gauge controller in a single compact unit. The gauge operates as a hot filament ionisation gauge, in which the pressure is measured indirectly as a function of the current.

The measurement range of the AIGX is 5×10^{-10} to 5×10^{-2} Torr (6.6×10^{-10} to 6.6×10^{-2} mbar). Three types of vacuum connections are available: DN16CF, DN40CF and NW25.

The AIGX requires a 14.5 - 30 V d.c. power supply; it has a 0 to 10 V d.c. analogue output which is related to pressure.

A 9-way electrical connector socket on the AIGX (Figure 1, item 1) is used to connect the AIGX to your electrical supply and voltmeter.

The AIGX is supplied with two filaments. A switch on top of the gauge selects between filament 1 and 2 (Figure 1, item 2).

There are two levels of emission currents: 0.1 and 1 mA. The 0.1 mA emission current should be used at pressures higher than 10^{-5} Torr and the 1mA emission current should be used at pressures lower than 10^{-5} Torr.

A protection circuit is built into the gauge to prevent operating the gauge at pressures higher than 5×10^{-2} Torr.

The AIGX can be degassed using the degas feature. During degas, the grid voltage is 500 V and the emission current is 10 mA. The degas is inhibited at high pressure. The maximum duration of degas is three minutes, after which the gauge returns automatically to its normal mode.

The AIGX is fitted with a status LED (Figure 1, item 3) . This LED indicates the operating status of the gauge.

Figure 1 - General View of the AIGX

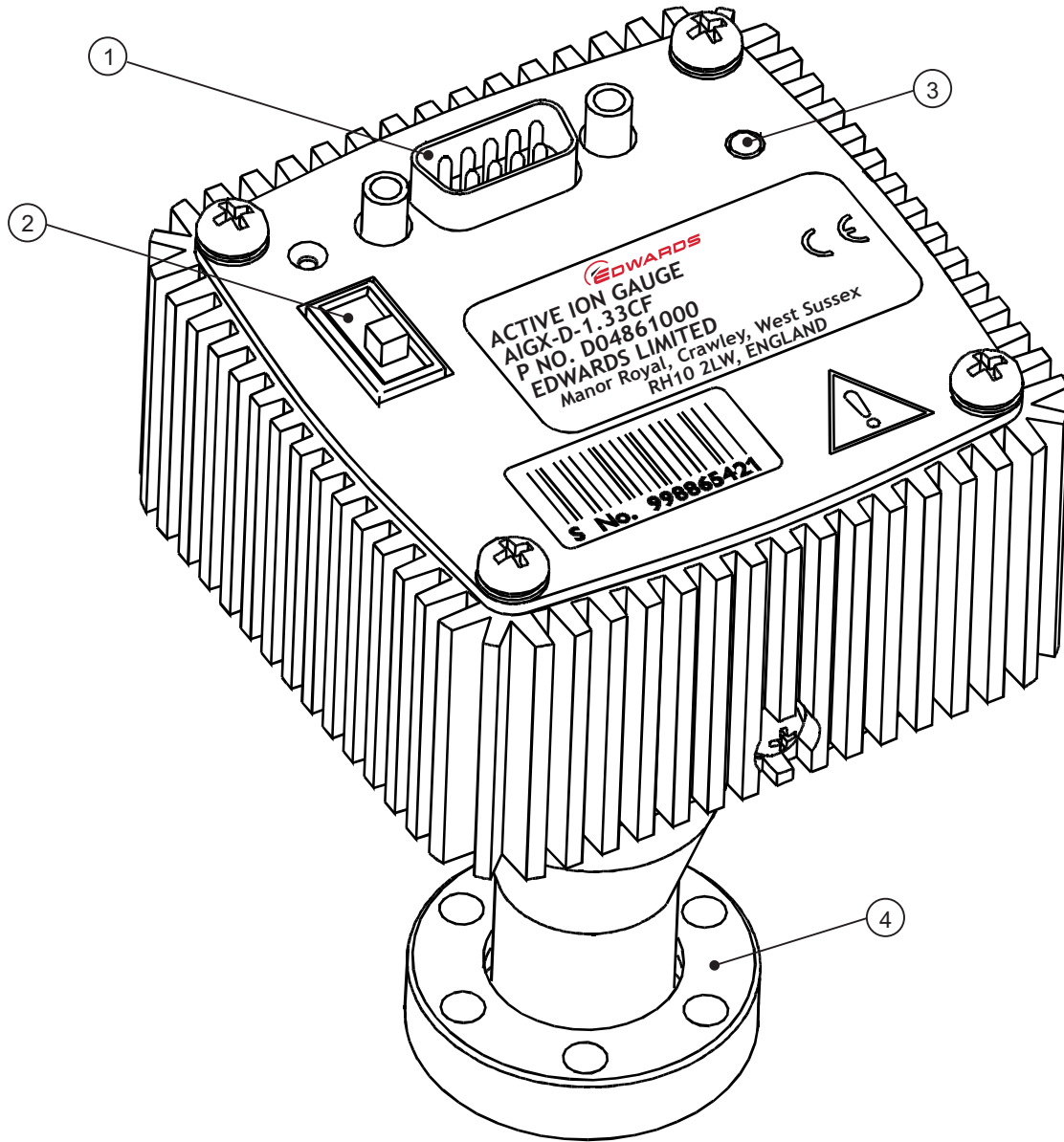

- 1. Electrical connector
- 2. Filament select switch
- 3. Status LED
- 4. Vacuum flange

2 Technical Data

2.1 Mechanical data

Dimensions	See Figure 2
Mass	
AIGX-D-NW25	260 g
AIGX-D-DN16CF	300 g
AIGX-D-DN40CF	510 g
Volume of gauge tube	21 cm ³
Enclosure rating	IP30

2.2 Performance, operating and storage conditions

Ambient temperature	
operation	0 to 40°C
storage	-30 to 70°C
Ambient humidity	90% RH (non-condensing) up to 31°C reducing to 50 % RH at 40°C
Atmosphere	Dry non-conductive only (pollution degree 1)
Bakeout temperature	200°C (with electronics removed)
Maximum operating altitude	2000 m
Maximum internal pressure	10 bar absolute
Pressure measurement range	5 x 10 ⁻¹⁰ to 5 x 10 ⁻² Torr (6.6 x 10 ⁻¹⁰ to 6.6 x 10 ⁻² mbar)

2.3 Electrical data

2.3.1 Electrical supply

Voltage	+14.5 V to +30 V d.c.
Internal fuse	1 A (T)
Maximum power consumption	
Operating	7 W
Degas	14 W
Electrical connector	9-way 'D' type male

2.3.2 Output signal

Measurement range	0.7 V to 8.7 V
Gauge disabled	10.0 V
Minimum load impedance	10 kW

2.3.3 Gauge and degas enable

Control sense	Active low
Active level	< 1.5 V

2.3.4 Status outputs

Load rating	30 V d.c., 100 mA max
Back EMF suppression diode *	
Min surge rating	1 A
Min reverse voltage rating	100 V

* required when you use an external d.c. relay connected to the status outputs

2.3.5 Electrodes

Emission current	
Normal	0.1 or 1 mA
Degas	10 mA
Grid voltage	
Normal	180 V
Degas	500 V
Filament bias voltage	+30 V
Collector voltage	0 V

2.4 Materials exposed to vacuum

Collector	Tungsten
Grid	Tantalum Pt Clad Mo
Filament	Yttria coated iridium
Body	Stainless Steel
Feedthrough	Stainless Steel and UHV compatible, glass/ceramic

Figure 2 - Dimensions

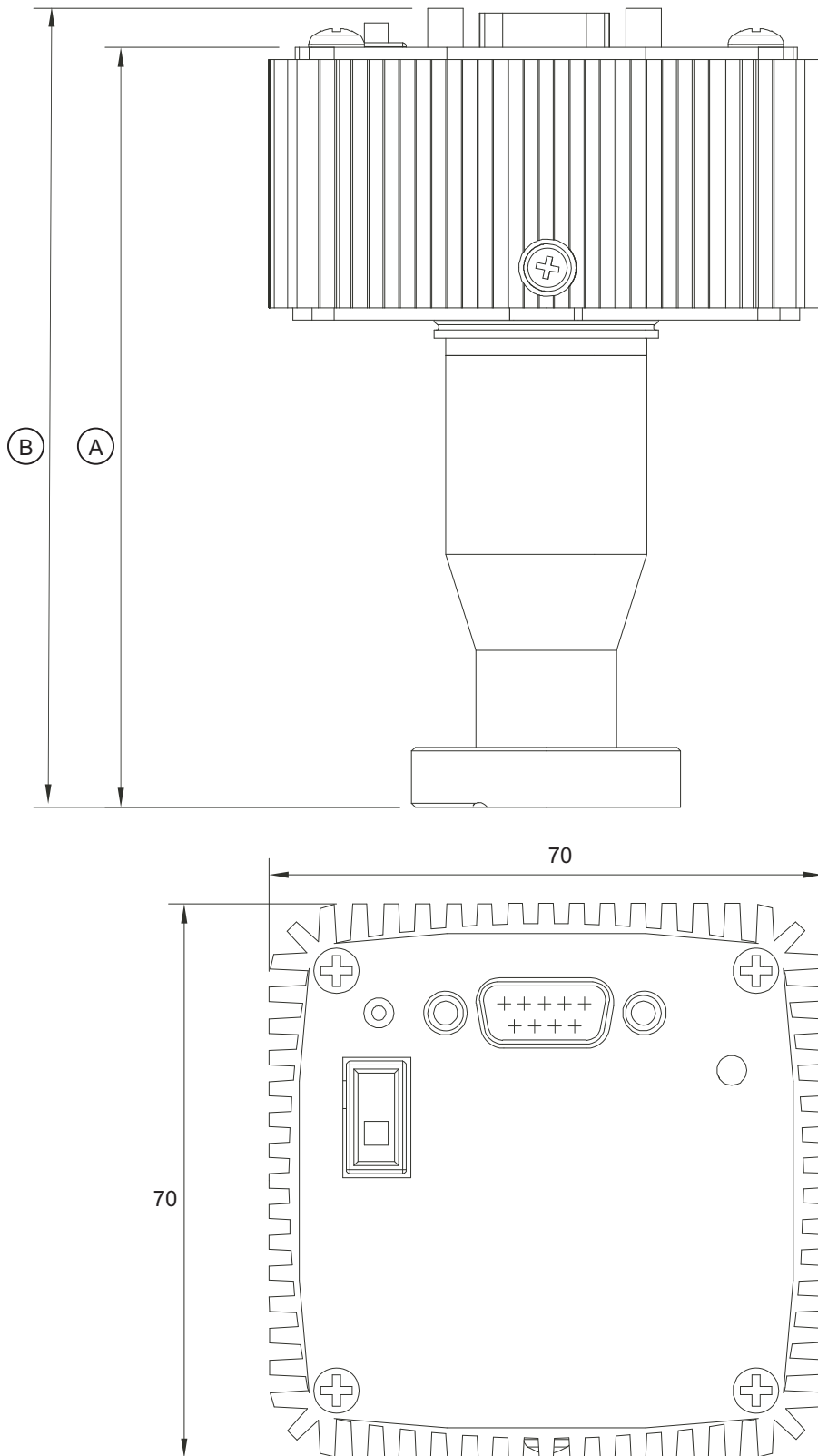

This page has been intentionally left blank.

3 Installation

3.1 Unpack and inspect

Remove all packing materials and protective covers and check the AIGX .

If the AIGX is damaged, notify your supplier and the carrier in writing within three days; state the Item Number of the gauge together with your order number and your supplier's invoice number. Retain all packing materials for inspection. Do not use the AIGX if it is damaged.

If the AIGX is not to be used immediately, replace the protective covers. Store the AIGX in suitable conditions as described in Section 6.

3.2 Fit the AIGX to the vacuum system

The AIGX can be mounted in any orientation. To avoid the build-up of debris or condensable material in the body tube of the AIGX (which will probably cause pressure measurement errors), we recommend that you install the AIGX vertically with the flange facing down.

Use a copper gasket and screws to connect the DN16CF and DN40CF flanges of the AIGX to a similar flange on your vacuum system. Use an O-ring / centring-ring or Co-Seal and metal clamp to connect the NW25 flange of the AIGX to a similar flange on your vacuum system.

Note: O-rings are not recommended for systems where UHV pressures are required.

3.3 Electrical connections



WARNING

The AIGX must be connected to an earthed (grounded) vacuum system. For gauges with a NW25 flange, a conductive metallic clamping ring must be used.



WARNING

If the AIGX malfunctions, the AIGX pressure output may be incorrect. If such a failure could result in damage to equipment or cause injury to people, you must install a suitable control system to indicate the failure and, if necessary, to close down your process system.

3.3.1 Connect to your own supply and control equipment

Note: Do not connect the electrical supply common (pin 2) to the signal common (pin 5). If you do, the AIGX pressure output signal will be inaccurate.

A schematic diagram of the recommended electrical connections to the AIGX is shown in Figure 3.

The pins on the AIGX connector are used as shown in Table 1. The specification of the electrical supply, d.c. relay and back EMF suppression diode are given in Section 2.

The connection to Pins 5 and 9 are optional. Make the connection to these pins if you want to monitor the emission status and degas status signals. If you want to connect d.c. relays to pins 5 and 9, you must connect a suppression diode between pins 4 to 5 and 4 to 9 to protect the AIGX from transient voltage generated when the d.c. relays are switched off.

Connect a switch between pins 1 and 2 to enable and disable the gauge.

Connect a switch between pins 6 and 2 to enable and disable the degas function.

Table 1 - Pins on the AIGX Connector

Pin No.	Use
1	Gauge enable
2	Supply common
3	Signal output
4	Supply positive
5	Degas status
6	Degas enable
7	Signal common
8	Emission current select
9	Emission status

Connect a switch between pins 8 and 2 to select between 0.1 and 1.0 mA emission current. Connecting pin 8 to pin 2 will increase the emission current from 0.1 to 1.0 mA.

Figure 3 - Schematic Diagram of Recommended Electrical Connections

- A AIGX connector (socket)
- B Cable electrical (plug)
- C Back EMF suppression diode (optional)
- D Degas status relay (optional)
- E Emission status relay (optional)
- F Gauge enable switch
- G Degas enable switch
- H Emission current select switch
- I View of AIGX connector

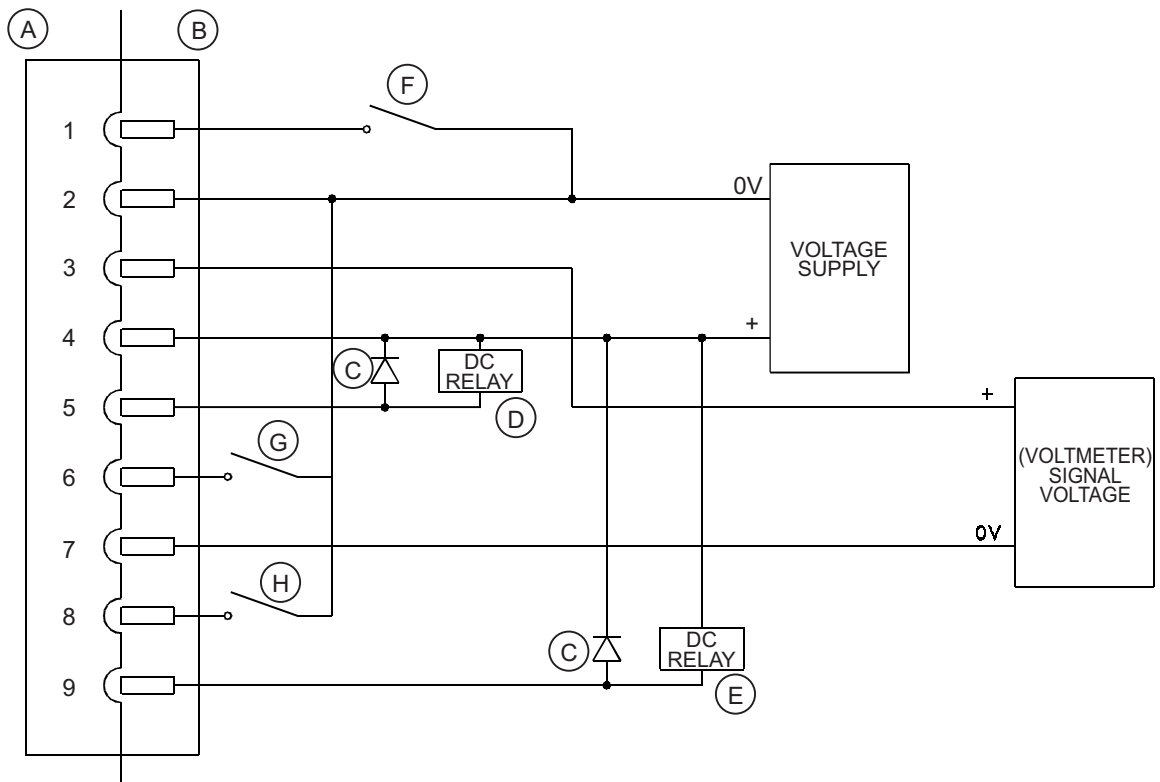
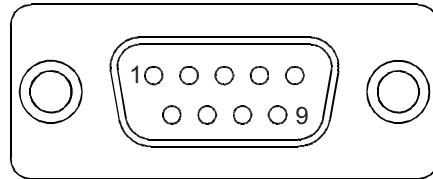

3.3.2 Maximum cable length

The maximum cable length is dependent on the conductor cross-section and the supply voltage used. The following maximum cable lengths are recommended:

Table 2 - Maximum Recommended Cable Length

Conductor cross-section	24 V Supply	15 V Supply
0.75 mm ²	100 m	10 m
0.5 mm ²	75 m	6 m
0.34 mm ²	50 m	4.5 m
0.22 mm ²	30 m	3 m

The common mode signal voltage (that is, the voltage between signal common and supply common) could be as much as 2.5 V with long cables due to the voltage drop in the supply cable. You should ensure that the signal voltage measurement will operate correctly.

This page has been intentionally left blank.

4 Operation



WARNING

Do not use the AIGX to measure the pressure of explosive or flammable gases or mixtures.



WARNING

During operation, the surface of the ion gauge tube might become hot. To avoid risk of injury, do not touch the tube whilst the gauge is operating. Switch off the gauge and allow to cool down for few minutes before handling.



WARNING

Disconnect the electrical supply cable from the AIGX before you remove the AIGX from the vacuum system. High voltages are generated inside the AIGX.

4.1 Enable and disable the AIGX

CAUTION

The gauge should not be operated at pressures higher than 5×10^{-2} Torr (6.6×10^{-2} mbar). Operating the AIGX at high pressures may reduce the lifetime of the filament.

To enable (switch on) the AIGX, connect pin 1 to pin 2. To disable (switch off) the AIGX, disconnect pin 1 from pin 2.

When the AIGX is enabled, the output signal will remain at 10.0 V whilst the emission current is being stabilised. This will take typically 5 seconds (may be longer at lower pressures). After this time the output signal will indicate pressure.

4.2 Pressure measurement

Convert the output signal to pressure using the following equation:

$$P = 10^{(V - 10)} \text{ Torr}$$

$$P = 10^{(V - 9.875)} \text{ mbar}$$

$$P = 10^{(V - 7.875)} \text{ Pa}$$

where V is the measured voltage in volts. Refer to [Figure 4](#). This formula is valid for the range 0.7 V to 8.7 V.

4.2.1 Calibration in different gases

The equation given in [Section 4.2](#) is for air or nitrogen only. For other gases, the indicated pressure has to be multiplied by a gas calibration factor (GCF).

Table 3 lists the gas calibration factor for most commonly used gases.

Table 3 - Gas Calibration Factors For Various Gases

Gas	GCF
Helium	5.7
Argon	0.75
Neon	3.3
Krypton	0.5
Xenon	0.35
Hydrogen	2.4
Oxygen	1.0
Carbon Monoxide	1.15
Carbon Dioxide	0.7

Figure 4 - Pressure Output Signal of AIGX

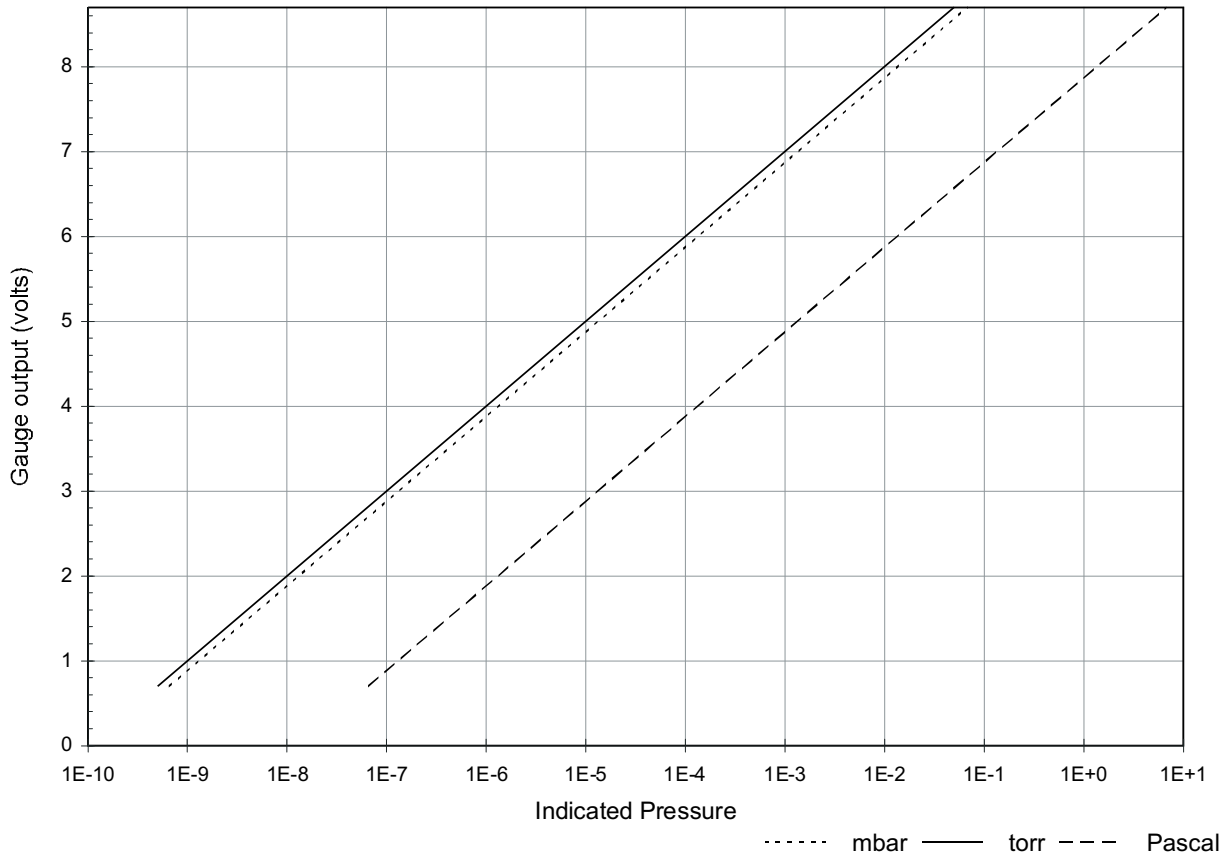

4.3 Emission current selection

The AIGX has two levels of emission current: 0.1 mA and 1.0 mA. You can use the high emission current up to a pressure of 1×10^{-3} Torr (1.3×10^{-3} mbar), and the low emission current up to a pressure of 5×10^{-2} Torr (6.6×10^{-2} mbar). However, to extend the lifetime of the gauge, we recommend that you use the low emission current at pressures higher than 1×10^{-5} Torr (1.3×10^{-5} mbar). To select the higher emission current, connect pin 8 to pin 2. To select the lower emission current, disconnect pin 8 from pin 2.

You can monitor the emission status at pin 9. When the emissions are off, the open collector transistor is off. When the emissions are on, the open collector transistor is on.

4.4 Degas the AIGX

CAUTION

You must degas the AIGX regularly. Failure to do so will affect the performance and reduce the lifetime of the gauge.

During use in contaminating environments the gauge electrodes become coated in insulating layers, eventually resulting in premature failure of the product. This can be prevented by regular use of the degas feature. Typically, degas will be required on a weekly basis although the interval will depend on the level of contamination.

The degas operation is also recommended if measurement of low pressure are required.

During degas, the grid will be heated to high temperature, sufficient to remove absorbed gases and some contamination.

Degas the AIGX when the pressure is below 1×10^{-5} Torr (1.3×10^{-5} mbar). The degas is inhibited when the pressure is above 1×10^{-4} Torr (1.3×10^{-4} mbar). The gauge will automatically return to the normal operation mode after 3 minutes.

To enable degassing of the AIGX, connect pin 6 to pin 2. To disable degassing of the AIGX, disconnect pin 6 from pin 2.

You can monitor the degas status at pin 5. When the degas is operating the open collector transistor is on. When the degas is off, the open collector transistor is off.

4.5 Over-pressure protection

The gauge will automatically switch off when the measured pressure rises above 5×10^{-2} Torr (6.6×10^{-2} mbar) or 1×10^{-3} Torr (1.33×10^{-3} mbar) if the high emission current is selected. If this occurs then the LED status will indicate over-pressure trip. Refer to [Section 4.7](#).

4.6 Filament selection

The AIGX has two filaments, 1 and 2. To select either of these filaments, use the sliding switch at the top of the gauge. Make sure that the gauge is turned off before switching between filaments.

4.7 LED status

The AIGX is fitted with a tri-coloured LED which can be used to monitor the status of the gauge according to [Table 4](#).

Table 4 - LED Status

Colour	Status
Off	No power to the gauge or malfunction
Amber	Power on, gauge disabled
Green/Amber (alternating)	Emissions start-up
Green	Emission on
Green (slow flashing)	Degas on
Red (flashing)	Emission error
Red	Over-pressure trip

4.8 Bakeout

The AIGX tube can be baked to temperatures up to 200°C (392°F) after removing the electronics housing. Refer to Figure 5 and the procedure in Section 5.2 to remove and refit the electronics housing.

Ensure that the tube has cooled down before refitting the electronics housing.

Figure 5 - Separate the Electronics Housing from the Body Tube

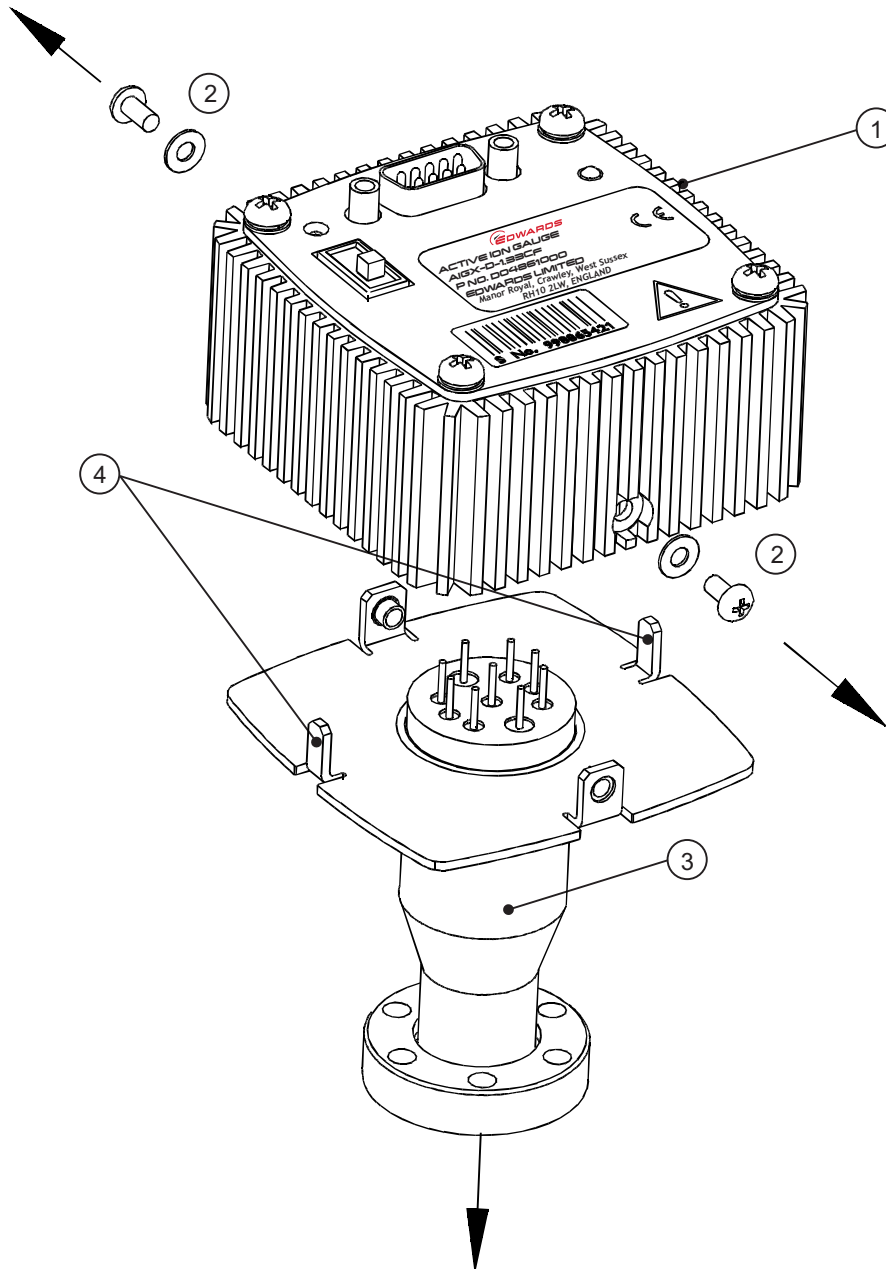

- 1. Electronics housing
- 2. Fixing screws
- 3. Body tube assembly
- 4. Locating lugs

5 Maintenance



WARNING

Disconnect the electrical supply cable before you start any maintenance. High voltages are generated inside the AIGX.

5.1 Fault finding guide

Table 5 - Fault Finding Guide

Symptom	Possible Cause	Remedy
LED Not Lit	Supply connection incorrect or faulty. Supply polarity reversed.	Check electrical supply and connections.
	Internal fuse blown.	Replace fuse. Refer to Section 5.3
Over-pressure trip	The pressure rose too high whilst the AIGX was operating.	Reduce the pressure and re-enable the AIGX.
Emission error	The AIGX was enabled when the pressure was too high.	Reduce the pressure and re-enable the AIGX.
	Filament contaminated. Filament open circuit.	Switch to the other filament. If both filaments give the error, replace the body tube. Refer to Section 5.2 .
	Electrical supply insufficient to drive the AIGX.	Check that supply voltage/current specifications meet requirement in Section 2.3.1 .

5.2 Replace the body tube

Refer to [Figure 5](#) and use the following procedure to replace the body tube.

1. Turn off the gauge.
2. Switch off the AIGX electrical supply and disconnect the electrical supply cable.
3. Remove the AIGX from the vacuum system.
4. Using a suitable screwdriver, remove the two M3 screws (item 2) from the sides of the electronics housing (item 1).
5. Pull the electronics housing (item 1) to remove it from the body tube assembly (item 3).
6. Fit the new body tube assembly (item 3) to the electronics housing (item 1). Take care to ensure that the locating lugs (item 4) on the body tube assembly (item 3) are aligned with the mating recess in the electronics housing (item 1). Note that the electronics housing (item 1) can only fit one way round on the body tube assembly (item 3).
7. Refit the two M3 screws to the sides of the AIGX.

5.3 Replace the internal fuse

If you suspect that the internal fuse has blown, you should check that the voltage and polarity of the electrical supply are correct before replacing the fuse.

To replace the fuse refer to [Figure 6](#) and use the following procedure:

1. Switch off the electrical supply and remove the electrical supply connector from the gauge.
2. Using a suitable screwdriver, remove the four M3.5 screws from the top of the gauge.
3. Remove the gauge lid, ensuring the screw on the underside of the lid is not bent.
4. The fuse will now be visible on the PCB. Hold the board down and then pull the fuse from its fuseholder using an appropriate tool (for example, a small pair of pliers).
5. The replacement fuse is supplied mounted in a fuseholder. Remove the new fuse from its fuseholder and discard the new fuseholder.
6. Push the new fuse into the fuseholder on the PCB.
7. Refit the gauge lid ensuring that the screw is fitted in the shrouded earth socket next to the main connector. Refit the four M3.5 screws.
8. Apply power to the gauge and check that the LED is illuminated.

Replacement fuses are available from Edwards. Refer to [Section 7.2](#).

Figure 6 - Fuse Replacement

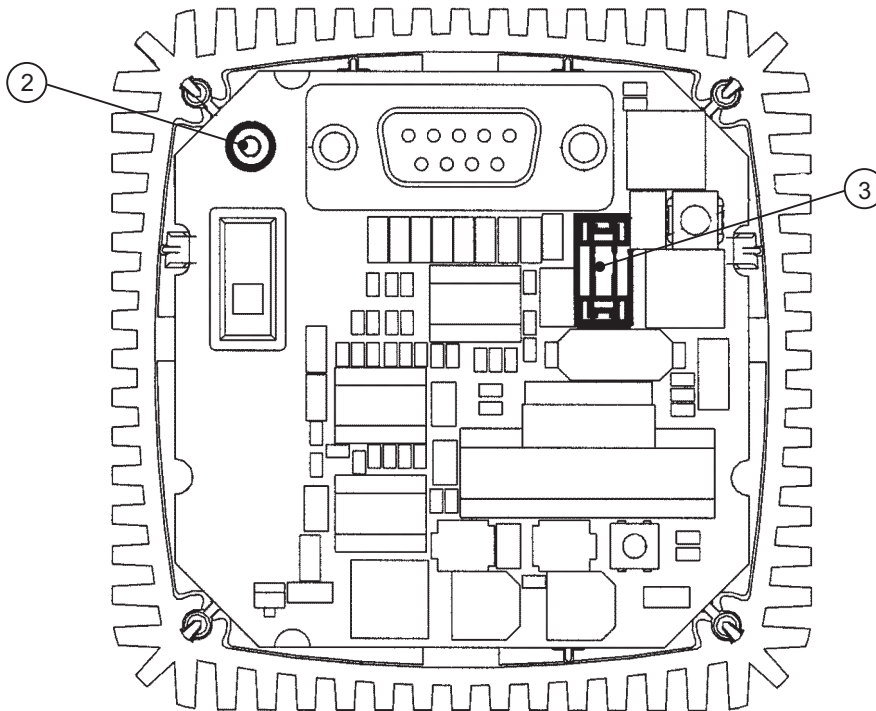

1. Fuse holder

2. Shrouded earth socket

5.4 Calibration service

A calibration service is available for all Edwards gauges. Calibration is by comparison with reference gauges, traceable to National Standards. Contact Edwards for details.

6 Storage and Disposal

6.1 Storage

Return the AIGX to its protective packaging and store the AIGX in clean dry conditions until required for use. Do not exceed the storage temperature conditions specified in [Section 2](#).

When required for use, prepare and install the AIGX as described in [Section 3](#).

6.2 Disposal

Disposal of the AIGX in accordance with all local and national safety and environmental requirements.

Alternatively, you may be able to recycle the AIGX and/or cables; contact Edwards or your supplier for advice (also see below).

The AIGX and associated cables are within the scope of the European Directive on Waste Electrical and Electronic Equipment, 2002/96/EC. From August 2005, Edwards will offer European customers a recycling service for the AIGX/cables at the end of the product's life. Contact Edwards for advice on how to return the AIGX/cables for recycling.

This page has been intentionally left blank.

7 Spares and Accessories

7.1 Introduction

Edwards products, spares and accessories are available from Edwards companies in Belgium, Brazil, Canada, France, Germany, Great Britain, Hong Kong, Italy, Japan, Korea, Switzerland, U.S.A, and a world wide network of distributors. The majority of these centres employ Service Engineers who have undergone comprehensive Edwards training courses.

Order spare parts and accessories from your nearest Edwards company or distributor. When ordering, please state for each part required:

- Model and Item Number of your equipment
- Serial number (if any)
- Item Number and description of part

7.2 Spares

Description	Item Number
Electronics housings	
AIGX-D	D048-60-800
Body tubes	
NW25	D048-50-801
DN16CF	D048-51-801
DN40CF	D048-52-801
Spare fuses (pack of 5)	D048-50-805

7.3 Accessories

Description	Item Number
Annealed copper gasket - DN16CF	C100-01-270
Hex head nut, bolt and washer kit - DN16CF	C100-01-630
Annealed copper gasket - DN40CF	C100-05-270
Hex head nut, bolt and washer kit - DN40CF	C100-05-630

This page has been intentionally left blank.