

***Block Valves
All Sizes***

INSTRUCTION MANUAL

Block Valves: Instruction Manual for All Sizes

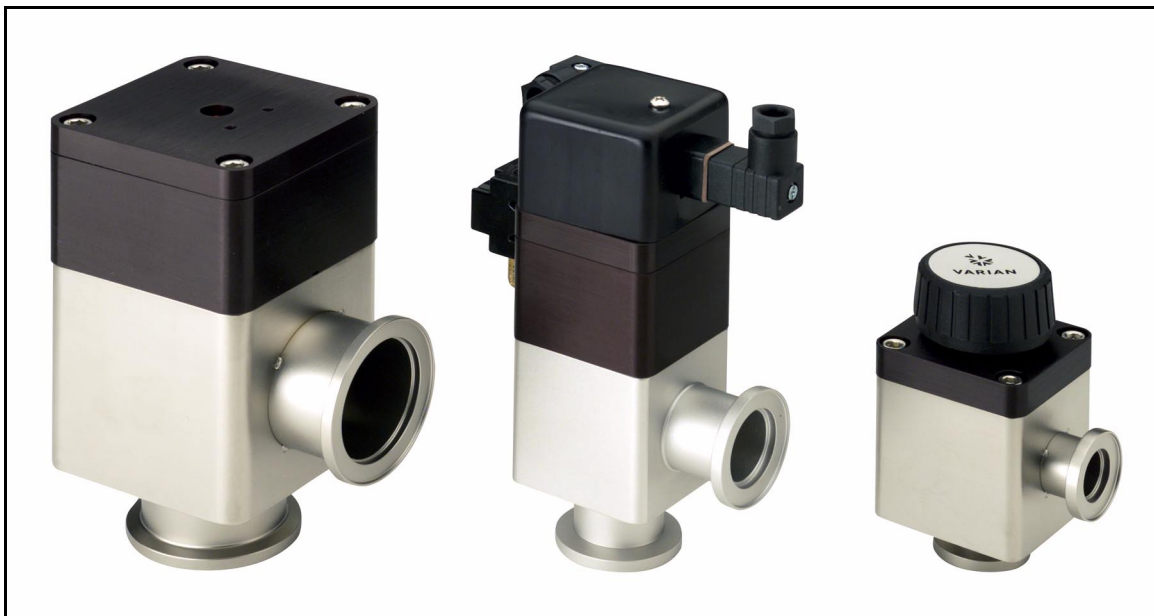

ConFlat Flange is a registered trademark of Varian, Inc.

Klamp-Flange and KF Clamp are registered trademarks of Varian, Inc.

Krytox is a registered trademark of DuPont Company

Loctite is a registered trademark of Loctite Corporation.

Scotch-Brite is a trademark of 3M.

Viton is a registered trademark of E. I du Pont de Nemours and Company.

Warranty

Products manufactured by Seller are warranted against defects in materials and workmanship for twelve (12) months from date of shipment thereof to Customer, and Seller's liability under valid warranty claims is limited, at the option of Seller, to repair, to replace, or refund of an equitable portion of the purchase price of the Product. Items expendable in normal use are not covered by this warranty. All warranty replacement or repair of parts shall be limited to equipment malfunctions which, in the sole opinion of Seller, are due or traceable to defects in original materials or workmanship. All obligations of Seller under this warranty shall cease in the event of abuse, accident, alteration, misuse, or neglect of the equipment. In-warranty repaired or replaced parts are warranted only for the remaining unexpired portion of the original warranty period applicable to the repaired or replaced parts. After expiration of the applicable warranty period, Customer shall be charged at the then current prices for parts, labor, and transportation.

Reasonable care must be used to avoid hazards. Seller expressly disclaims responsibility for loss or damage caused by use of its Products other than in accordance with proper operating procedures.

Except as stated herein, Seller makes no warranty, express or implied (either in fact or by operation of law), statutory or otherwise; and, except as stated herein, Seller shall have no liability under any warranty, express or implied (either in fact or by operation of law), statutory or otherwise. Statements made by any person, including representatives of Seller, which are inconsistent or in conflict with the terms of this warranty shall not be binding upon Seller unless reduced to writing and approved by an officer of Seller.

Warranty Replacement and Adjustment

All claims under warranty must be made promptly after occurrence of circumstances giving rise thereto, and must be received within the applicable warranty period by Seller or its authorized representative. Such claims should include the Product serial number, the date of shipment, and a full description of the circumstances giving rise to the claim. Before any Products are returned for repair and/or adjustment, written authorization from Seller or its authorized representative for the return and instructions as to how and where these Products should be returned must be obtained. Any Product returned to Seller for examination shall be prepaid via the means of transportation indicated as acceptable by Seller. Seller reserves the right to reject any warranty claim not promptly reported and any warranty claim on any item that has been altered or has been returned by non-acceptable means of transportation. When any Product is returned for examination and inspection, or for any other reason, Customer shall be responsible for all damage resulting from improper packing or handling, and for loss in transit, notwithstanding any defect or non-conformity in the Product. In all cases, Seller has the sole responsibility for determining the cause and nature of failure, and Seller's determination with regard thereto shall be final.

If it is found that Seller's Product has been returned without cause and is still serviceable, Customer will be notified and the Product returned at Customer's expense; in addition, a charge for testing and examination may be made on Products so returned.

3/1/00

This page intentionally left blank.

Contents

Preface	xi
Document Conventions	xi
Contacting Vacuum Technologies	xi
Declaration of Conformity	
Introduction and Installation	1-1
Installation	1-3
Electrical Connections to Solenoid	1-4
Operation	1-5
Manually-Operated Valves.....	1-5
Pneumatically-Operated Valves	1-5
Maintenance.....	1-6
Manual Valves	1-6
Pneumatic Valves.....	1-11
Appendix A. Technical Specifications	A-1
Appendix B. Spare Parts Kits/Accessories and Replacement Parts	B-1
Request for Return Health and Safety Certification	
Sales and Service Offices	

This page intentionally left blank.

List of Figures

Figure	Caption	Page
1-1	KF Coupling.....	1-3
1-2	Solenoid Assembly.....	1-4
1-3	Solenoid Operation.....	1-5
1-4	Small and Large Manual Block Valve – Exploded View.....	1-6
1-5	Small and Large Pneumatic Block Valve – Exploded View.....	1-11
1-6	Positioning the Quad Ring in the Air Cylinder.....	1-15
1-7	Removing the Stem from the Seal Disc.....	1-15
1-8	Position of Quad Ring In its Groove.....	1-17
1-9	Position Indicator Assembly Exploded View.....	1-19
1-10	Wiring Diagram – Position Indicator.....	1-23

This page intentionally left blank.

List of Tables

Table	Title	Page
1-1	Valve Ordering Information NW16 – NW25.....	1-2
1-2	Valve Ordering Information NW50 – NW80.....	1-2
1-3	Small Block Valves: Manual Valve Parts List	1-7
1-4	Large Block Valves: Manual Valve Parts List	1-7
1-5	Small Valves: Pneumatic Valve Parts List	1-12
1-6	Large Block Valves: Pneumatic Valve Parts List.....	1-13
1-7	Position Indicator Parts List	1-20
1-8	Connector Base Wiring	1-21
A-1	Block Valve Specifications	A-1
B-1	Spare Part Kits	B-1
B-2	KF Clamp [®] and Centering Ring Ordering Information	B-2

This page intentionally left blank.

Preface

Document Conventions

This manual uses the following standard safety protocols:

WARNING



The warning messages are for attracting the attention of the operator to a particular procedure or practice which, if not followed correctly, could lead to serious injury.

CAUTION



The caution messages are displayed before procedures, which if not followed, could cause damage to the equipment.

NOTE



The notes contain important information.

This product must only be operated and maintained by trained personnel.

Before operating or servicing equipment, read and thoroughly understand all operation/maintenance manuals provided by Vacuum Technologies. Be aware of the hazards associated with this equipment, know how to recognize potentially hazardous conditions, and how to avoid them. Read carefully and strictly observe all cautions and warnings. The consequences of unskilled, improper, or careless operation of the equipment can be serious.

In addition, consult local, state, and national agencies regarding specific requirements and regulations. Address any safety, operation, and/or maintenance questions to your nearest Vacuum Technologies office.

Contacting Vacuum Technologies

In the United States, you can contact Vacuum Technologies Customer Service at 1-800-8VARIAN.

Internet users:

- Send email to Customer Service & Technical Support at vpl.customer.support@varianinc.com
- Visit our web site at www.varianinc.com/vacuum
- Order on line at www.evarian.com

**Declaration of Conformity
Konformitätserklärung
Déclaration de Conformité
Declaración de Conformidad
Verklaring de Overeenstemming
Dichiarazione di Conformità**



We
Wir
Nous
Nosotros
Wij
Noi

Varian, Inc.
Vacuum Technologies
121 Hartwell Avenue
Lexington, MA, 02421-3133 USA

declare under our sole responsibility that the product,
erklären, in alleiniger Verantwortung, daß dieses Produkt,
déclarons sous notre seule responsabilité que le produit,
declaramos, bajo nuestra sola responsabilidad, que el producto,
verklaren onder onze verantwoordelijkheid, dat het product,
dichiariamo sotto nostra unica responsabilità, che il prodotto,

Aluminum GateKeeper Valves	NW100, NW160, NW200, NW250,
Aluminum Butterfly Valves	NW63, NW100, NW160, NW200, NW250,
Aluminum Block Valves	NW16, NW25, NW40, NW50, NW63, NW80,
Stainless Steel Block Valves	NW16, NW25, NW40,
Stainless Steel Tube Valves	NW16, NW25, NW40

to which this declaration relates is in conformity with the following standard(s) or other normative documents.
auf das sich diese Erklärung bezieht, mit der/den folgenden Norm(en) oder Richtlinie(n) übereinstimmt.
auquel se réfère cette déclaration est conforme à la (aux) norme(s) ou au(x) document(s) normatif(s).
al que se refiere esta declaración es conforme a la(s) norma(s) u otro(s) documento(s) normativo(s).
waarnaar deze verklaring verwijst, aan de volgende norm(en) of richtlijn(en) beantwoordt.
a cui si riferisce questa dichiarazione è conforme alla/e seguente/i norma/o documento/i normativo/i.

98/37/EEC, Machinery Directive

EN 60204-1 Electrical equipment of industrial machines; general requirements

A handwritten signature in black ink that reads "Frederick C. Campbell".

Frederick C. Campbell
Operations Manager
Vacuum Technologies
Varian, Inc.
Lexington, Massachusetts, USA

April 2002



Section 1. Introduction and Installation

Vacuum Technologies small right-angle and in-line block valves are compact bellows-sealed valves for use in roughing and high vacuum applications. The valve body is made of aluminum or stainless steel, and incorporates Klamp-Flange[®], CFF or tube end fittings to provide reliable and convenient vacuum connections. The main seal and all vacuum seals are Viton[®].

The valves are available in manually-operated and pneumatically-operated versions. The pneumatic valve is also available with a position indicator. The position indicator delivers an electrical output signal when the valve cycles, and is user-set in either the normally-open or normally-closed position.

The NW 16 and NW 25 valves are identical except for their port sizes; therefore, all internal spare parts are interchangeable. The NW 40 valve, however, is a larger-bodied valve requiring different internal components.

The NW 50, NW 63 and NW 80 are available only as stainless steel, right-angle valves.

This manual contains the necessary information to install, operate and maintain the Vacuum Technologies block valves listed in Table 1-1 and Table 1-2 on page 1-2.

Refer to the following sections:

- ❑ “Installation” on page 1-3
- ❑ “Operation” on page 1-5
- ❑ “Maintenance” on page 1-6

Block Valves: Instruction Manual for All Sizes

Table 1-1 Valve Ordering Information NW16 – NW25

Valve	Material	Right-Angle, All Models Part No.	In-Line, All Models Part No.
Manually-operated	Aluminum	L6280	L9180
	Stainless Steel	L9480	L9580
Pneumatically-operated (with or without solenoid, without position indicator)	Aluminum	L6281	L9181
	Stainless Steel	L9481	L9581
Pneumatically-operated (with or without solenoid, with position indicator)	Aluminum	L6282	L9182
	Stainless Steel	L9482	L9582

Table 1-2 Valve Ordering Information NW50 – NW80

Valve	Material	Right-Angle, All Models Part No.
Manually-operated	Aluminum	L72803
Pneumatically-operated (with or without solenoid, with position indicator)	Aluminum	L72823

1.1 Installation

All valves are installed in a vacuum system by brazing welding, Conflat[®] gaskets, or Klamp-Flange[®] or KF couplings.

KF coupling Consists of two symmetrical flange fittings (one of which is on the valve body), a centering ring, an O-ring and a flange clamp (Figure 1-1).

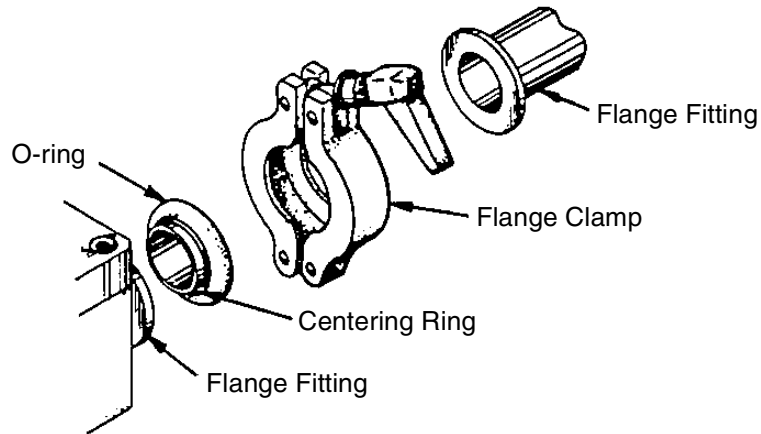

Figure 1-1 KF Coupling

NW 50 valves Installed in a vacuum system by means of a Klamp[®] (Quick Clamp) flange or ISO coupling.

ISO 63 and ISO 80 valves Installed using an ISO coupling consisting of two symmetrical flanges, a centering ring, and claw clamps.

To install the valve:

1. Wipe the O-ring clean and grease it very lightly with Dupont Krytox[®] GPL2O7 vacuum lubricant (Part No. 695400010) before installation.
2. Assemble the KF coupling and tighten the wing nut or ratchet firmly to ensure proper compression of the O-ring seal.



The pneumatic valve uses a 1/8 NPT inlet fitting and requires a minimum of 80 psig air pressure to operate.

3. Install a filter and lubricator in the air inlet line (pneumatic valve only).

1.1.1 Electrical Connections to Solenoid

To supply power to the solenoid:

1. Remove the connector from the solenoid by removing the holding screw and pulling the connector away from the solenoid.
2. Remove the terminal block from its housing by inserting a small, flat-head screwdriver in the slot provided at the terminal base and prying the housing off (Figure 1-2).

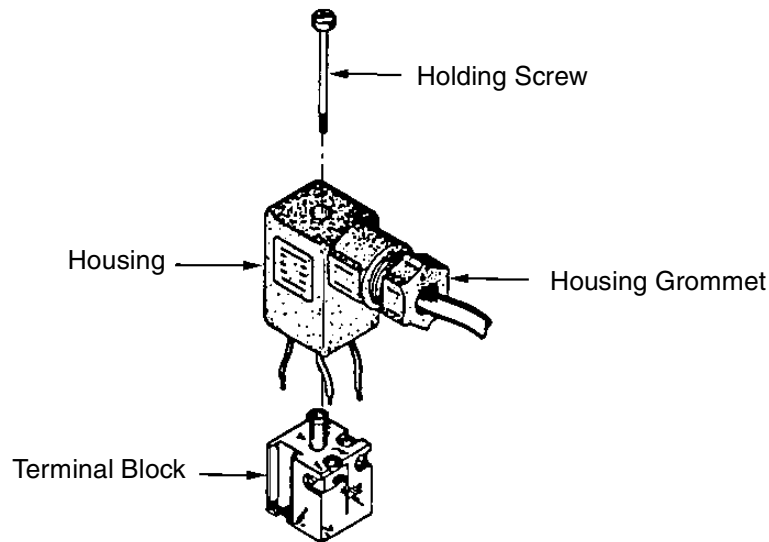

Figure 1-2 Solenoid Assembly

3. Feed the power line through the housing grommet and connect the three leads to the terminal contacts which are clearly labeled 1, 2, and $\underline{\underline{\text{I}}}$ (ground).
4. Push the terminal block back into the housing and snap it in place.



The housing can be rotated 360° in 90° increments so that the power line exits the connector in the most convenient direction.

5. Plug the connector back into the solenoid and tighten the holding screw.

1.2 Operation

This section discusses the operation of:

- ❑ “Manually-Operated Valves”
- ❑ “Pneumatically-Operated Valves”

1.2.2 Manually-Operated Valves

The manual valve operates by means of a hand-actuated knob.

To close the valve:

- ❑ Turn the knob in a clockwise direction. To properly compress the main O-ring seal and obtain a good vacuum seal, turn the knob clockwise until a slight resistance is felt, then firmly torque the knob approximately $\frac{1}{4}$ turn.

To open the valve:

- ❑ Turn the knob counterclockwise until the valve is fully open to ensure maximum conductance.

1.2.3 Pneumatically-Operated Valves

Pneumatic valves are spring-closed air-opened valves.

When electric power is:

- ❑ *Supplied* to the solenoid valve, air is supplied to the cylinder and the valve opens.
- ❑ *Removed*, the valve closes (Figure 1-3).

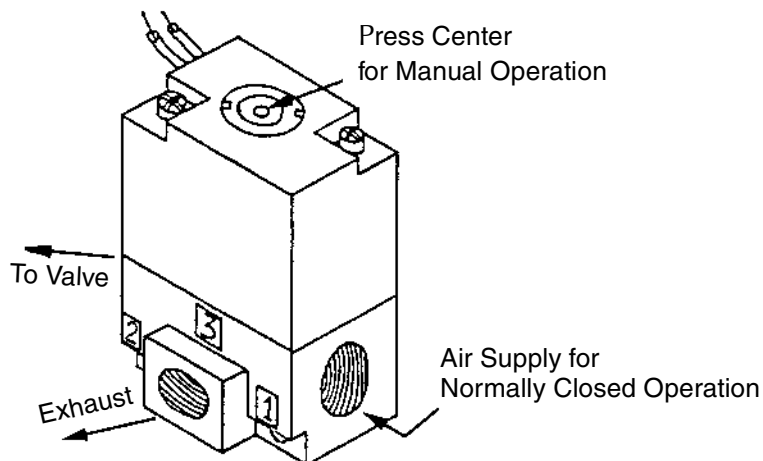

Figure 1-3 Solenoid Operation

1.3 Maintenance

This section discusses the maintenance of:

- ❑ “Manual Valves”
- ❑ “Pneumatic Valves” on page 1-11

1.3.4 Manual Valves

Manual valve maintenance consists of:

- ❑ “Disassembly and Cleaning” on page 1-8
- ❑ “Reassembly” on page 1-10

Figure 1-4 shows an exploded view of the small manual block valve and the large block valve. The numbers of the small block valve correspond to items in Table 1-3. The numbers of the large block valve correspond to items in 1-4.

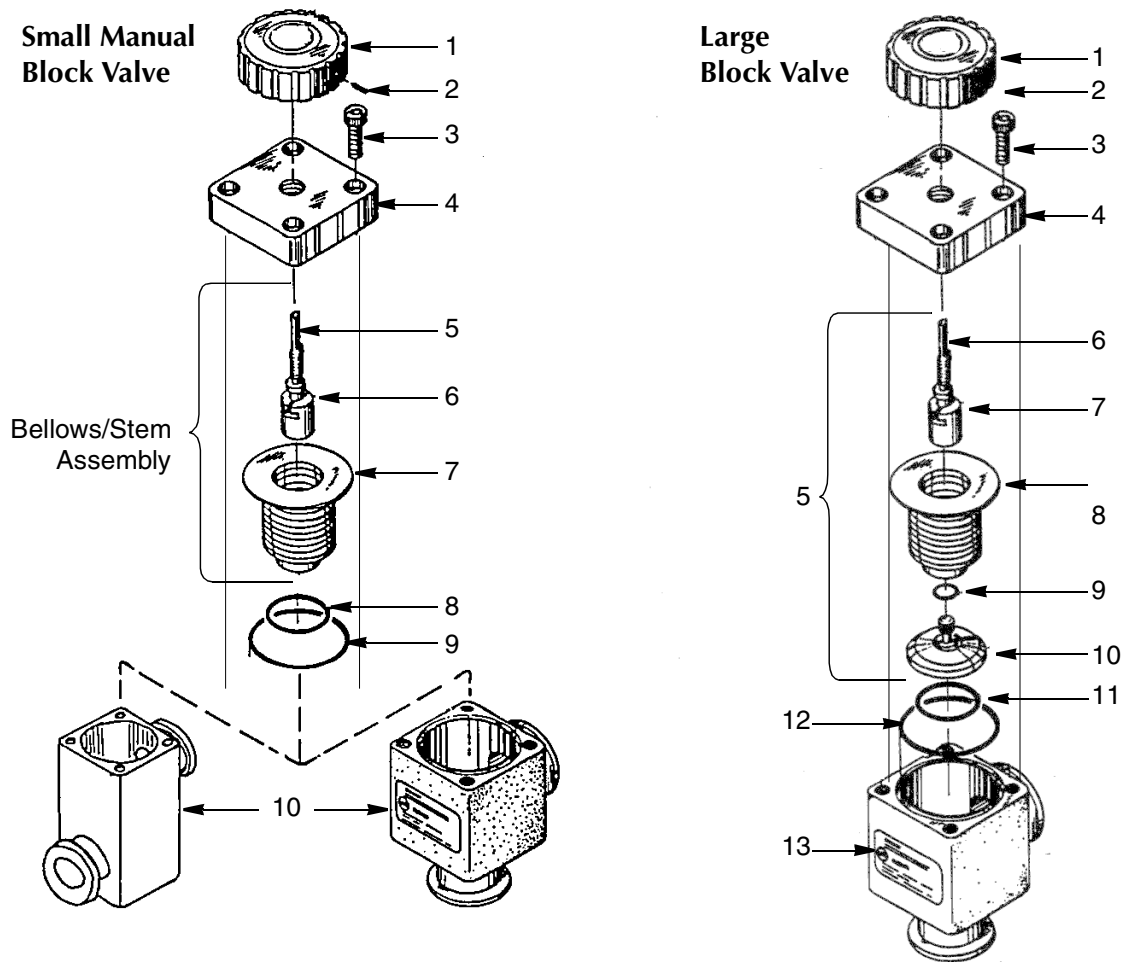

Figure 1-4 Small and Large Manual Block Valve – Exploded View

Block Valves: Instruction Manual for All Sizes

Table 1-3 Small Block Valves: Manual Valve Parts List

Item	Description	Vacuum Technologies Part No. or Equivalent	
		NW16 or NW25	NW40
1	Knob	L5967301 (aluminum)	L5698301 (aluminum)
		L8819001 (plastic)	L8818001 (plastic)
2	Set Screw	#10-32 x 5/8 lg	#10-32 x 1/2 lg
3	Screw, Allen head cap	#10-32 x 5/8 lg	#10-32 x 3/4 lg
4	Top Plate	L5491001	L5686001
5	Valve Stem	L5490001	L9684001
6	Bellows Nut	85073001	85073001
7	Bellows and Seal Disc	L8739301	L8738301
8	O-ring, Viton	Parker No.2-213	Parker No.2-223
9	O-ring Viton	Parker No.2-031	Parker No 2-039
10	Valve Body	–	–

Table 1-4 Large Block Valves: Manual Valve Parts List

Item	Description	Vacuum Technologies Part No. or Equivalent		
		NW50	ISO63	ISO80
1	Knob	L8819001 (plastic)	L8818001 (plastic)	L8818001 (plastic)
2	Set Screw	#10-32 x 1/2 lg	#10-32 x 1/2 lg	#10-32 x 1/2 lg
3	Screw Socket, Head Cap	#10-32 x 3/4 lg	#10-32 x 3/4 lg	#10-32 x 3/4 lg
4	Top Plate	L6606001	L6606001	L7283001
5	Bellow/Valve Stem Assembly	Ref	Ref	Ref
6	Valve Stem	L6608001	L6608001	L6606001
7	Bellows Nut	L6609001	L6609001	L6609001
8	Bellows	L6603001	L6603001	L6603001
9	O-ring, Bellows, Viton	66892014	66892014	66892014
10	Seal Disc	L6602001	L6985001	L9972001
11	O-ring, Seal Disc, Viton	660892227	660892231	660892234
12	O-ring, Bonnet, Viton	66892043	660892043	660892043

Block Valves: Instruction Manual for All Sizes

Table 1-4 Large Block Valves: Manual Valve Parts List (Continued)

Item	Description	Vacuum Technologies Part No. or Equivalent		
		NW50	ISO63	ISO80
13	Valve Body	L6600001	L9970401	L9971401
	Valve Body, Nickel-plated	L6600003	L9970003	L9971003

1.3.4.1 Disassembly and Cleaning

Refer to Figure 1-4 on page 1-6 for this procedure.



In this procedure, the components (shown in Figure 1-4, identified in Table 1-3 and Table 1-4) are enclosed in parentheses using the following convention:

- A single number refers to both the small and large valve.*
- In a set of numbers separated by a semi-colon:
 - The first item number identifies an item in the small block valve.*
 - The second item number identifies an item in the large block valve.**

To disassemble and clean the valve:

1. Loosen the set screw (2) with a 3/32 Allen wrench and pull the knob (1) off the valve stem (5; 6).
2. Remove the four Allen head cap screws (3) and pull the top plate (4) and bellows/valve stem assembly (7, 8, 9, and 10; 5) from the valve body as one unit. If only the main seal O-ring (8) is to be replaced, do so at this time and then reassemble the valve ("Reassembly" on page 1-10).
3. Holding the valve stem (5; 6) of the bellows/valve stem assembly ((8, 9, and 10; 5) between the fingers of one hand, unscrew the top plate (4) with the other hand and remove the plate from the valve stem (5; 6).

The bellows/valve stem assembly (7, 8, 9, and 10; 5) is treated as a single unit; its separate components, however, are listed on the parts list.

4. Remove the O-ring (8; 11) from the seal disc and the O-ring (9; 12) from the valve body (10; 13). Use plastic tweezers or a similar non-destructive instrument to remove the O-rings so as not to mar O-ring groove surfaces.

Block Valves: Instruction Manual for All Sizes

5. Clean the internal metal components using an alcohol-dampened cloth or a light abrasive cloth such as Scotch-Brite™.

CAUTION



When cleaning the parts of the bellows/valve stem assembly (7, 8, 9, and 10; 5) , wipe only the surface area of the bellows and seal disk exposed to the vacuum system. Soaking the bellows/valve stem assembly in an alcohol bath damages the O-ring (8) and causes it to outgas under vacuum.

1.3.4.2 Reassembly

Refer to Figure 1-4 on page 1-6 for this procedure.



In this procedure, the components (shown in Figure 1-4, identified in Table 1-3 and Table 1-4) are enclosed in parentheses using the following convention:

- ❑ *A series of numbers not separated by a semi-colon refer to both the small and large valve.*
- ❑ *In a series of numbers separated by a semi-colon:*
 - ❑ *The first item number identifies an item in the small block valve.*
 - ❑ *The second item number identifies an item in the large block valve.*

To reassemble the manual valve:



Use new O-rings (8 and 9; 9, 11 and 12) for this procedure.

1. Wipe new O-rings clean and very lightly grease them with Dupont Krytox[®] GPL2O7 vacuum lubricant.
2. Place O-rings (8 and 9) into their respective grooves.
3. Take the bellows/valve stem assembly (7, 8, 9, and 10; 5) and hold it securely in one hand. Using the other hand, thread the top plate (4) onto the valve stem (5; 6) until the top plate is flush with the bellows.
4. Place the bellows/valve stem assembly (7, 8, 9, and 10; 5) with the top plate into the valve body and secure with cap screws (3). Be sure the seal disc is not in contact with the seal area of the body before tightening the cap screws.
5. Push the knob onto the valve stem and secure it by tightening the set screw on the flat of the valve stem(5; 6).

1.3.5 Pneumatic Valves

Pneumatic valve maintenance consists of:

- ❑ “Disassembly and Cleaning” on page 1-14
- ❑ “Reassembly” on page 1-16
- ❑ “Position Indicator” on page 1-18 – discusses installation and servicing of the position indicator and microswitches

Figure 1-5 shows an exploded view of the small pneumatic block valve and the large pneumatic block valve. The numbers of the small block valve correspond to the items in Table 1-5. The numbers of the large block valve correspond to the items in Table 1-6 on page 1-13.

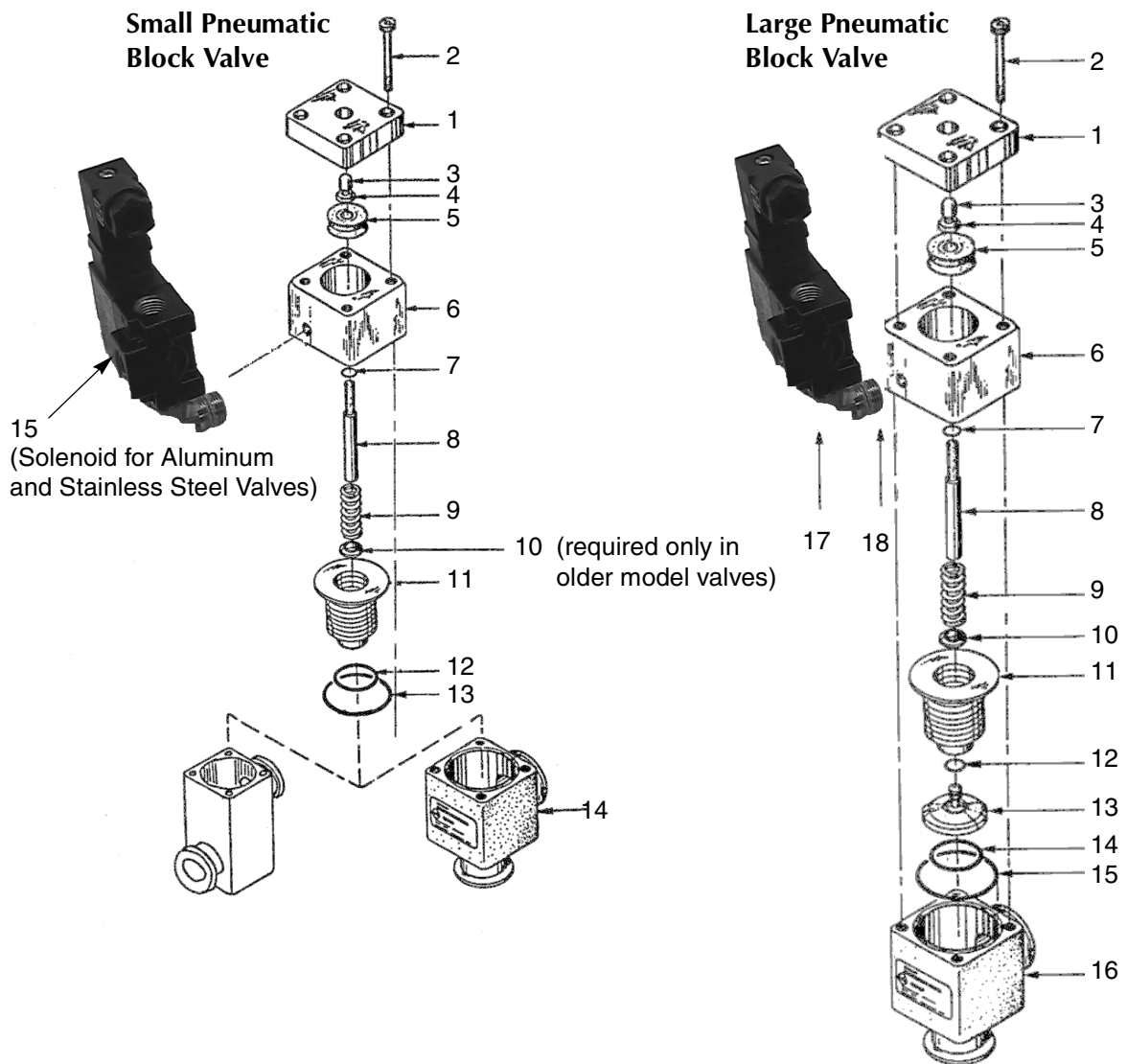

Figure 1-5 Small and Large Pneumatic Block Valve – Exploded View

Block Valves: Instruction Manual for All Sizes

Table 1-5 Small Valves: Pneumatic Valve Parts List

Item	Description	Vacuum Technologies Part No. or Equivalent	
		NW16 or NW25	NW40
1	Air cylinder Cover	L5484001	L5674001
2	Screw, Allen head cap	#10-32x 2 lg	#10-32 x 2¼ lg
3	Visual Indicator Cap	L5673-001	L5673001
4	Stop Nut	ESNA 29NTE 040	ESNA 29NTE 040
5	Piston Cup	660202114	660203125
6	Air Cylinder	L5480001	L5677001
7	Quad Ring	699000025	699000025
8	Valve Stem	L5483001	L5679001
9	Spring	660285312	660265073
10	Special Washer, Aluminum (not used on new models)	L5482001	L5678001
11	Bellows & Seal Disc	L8739301	L8738301
12	O-ring	Parker No. 2-213, Viton	Parker No. 2-223, Viton
13	O-ring	Parker No. 2-031, Viton	Parker No. 2-039, Viton
14	Valve Body	–	–
		Voltage/Hertz	Part No.
15	Solenoid kit for aluminum (solenoid valve and brass elbow) and stainless steel valves (solenoid valve and straight brass fitting)	110/115 V, 50/60 Hz	BVSOLKIT110
		220/240 V, 50/60 Hz	BVSOLKIT220
		24 VDC	BVSOLKIT24D

Block Valves: Instruction Manual for All Sizes

Table 1-6 Large Block Valves: Pneumatic Valve Parts List

Item	Description		Vacuum Technologies Part No. or Equivalent		
			NW50	ISO63	ISO80
1	Air Cylinder Cover		L6612001	L6612001	L9974001
2	Screw Allen Head Cap		1/4-20 x 21/4 lg	1/4-20 x 21/4 lg	1/4-20 x 21/4 lg
3	Visual Indicator Cap		L6611001	L6611001	L6611001
4	Stop Nut		617935016	617935016	617935016
5	Piston Cup		660203140	660203140	660203140
6	Air Cylinder		L6604001	L660400	L6604001
7	Quad Ring		699000026	699000026	699000026
8	Valve Stem		L6607001	L6607001	L6607001
9	Spring		660285698	660285698	660285698
10	Special Washer		L9973001	L9973001	L9973001
11	Bellows		L6603001	L6603001	L6603001
12	O-ring, Bellows, Viton		66892014	66892014	66892014
13	Seal Disc		L6602001	L6985001	L9972001
14	O-ring, Seal Disc, Viton		660892227	660892231	660892234
15	O-ring, Bonnet, Viton		660892043	660892043	660892043
16	Valve Body		L6600401	L9970401	L9971401
	Valve Body, Nickel-plated		L6600003	L9970003	L9971003
17	Solenoid	110/115 V, 50/50 Hz	626771150		
		220/240 V, 50/50 Hz	626771151		
		24 VDC	626771152		
18	Elbow 1/8 NPT	623434001	623434001	623434001	623434001

1.3.5.3 Disassembly and Cleaning

Refer to Figure 1-5 on page 1-11 for this procedure.



In this procedure, the components (shown in Figure 1-5, identified in Table 1-5 and Table 1-6) are enclosed in parentheses, using the following convention:

- A single number refers to both the small and large valve.*
- In a set of numbers separated by a semi-colon:
 - The first item number identifies an item in the small block valve.*
 - The second item number identifies an item in the large block valve.**

To disassemble and clean the valve:

1. Using a 5/8 wrench, turn the solenoid valve fitting (15; 17) counterclockwise and remove the complete solenoid valve assembly as one unit.
2. Place the solenoid valve assembly (15; 17) aside.
3. Unscrew the four cap screws (2) and remove the air cylinder cover (1).
4. Pull the air cylinder (6) away from the valve body (14; 16). All components except for the O-ring (13; 15) remain with the air cylinder.

This group of components is collectively referred to as the trim assembly. If only the main seal is to be replaced, do so at this time, then reassemble the valve. For more information, refer to "Reassembly" on page 1-16.

5. To disassemble the trim assembly, pull the red visual indicator cap (3) off the valve stem (8).
6. Using a 7/16" deep socket wrench, turn the stop nut (4) counterclockwise while gripping the bellows seal disc (11) in the other hand.
7. Remove the stop nut (4) and pull the air cylinder (6) away from the valve stem (8).
8. Proceed to:
 - Step 9 if disassembly of the air cylinder is necessary (e.g. an air leak is suspected).
 - Step 12 on page 1-15, if disassembly of the air cylinder is not required.
9. Place the air cylinder upside down on a flat surface with the large bore and piston cup insert (5) facing down.
10. Remove the piston cup insert from the air cylinder (6) by inserting the eraser end of a pencil (or similar non-destructive object) into the center bore of the air cylinder and pushing the piston cup out the other side.

11. Ensure that the air cylinder (6) is still in the upside down position, using plastic tweezers or other nondestructive instrument, pull the quad ring (7) out of the center bore of the air cylinder (Figure 1-6).



When removing the quad ring, care must be taken not to mar any metal surfaces, especially the groove in which the quad ring is positioned.

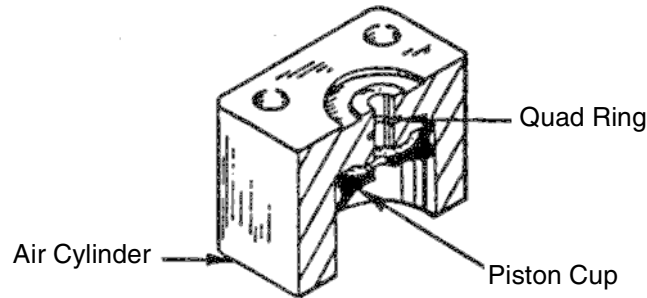

Figure 1-6 Positioning the Quad Ring in the Air Cylinder



Further disassembly requires a soft-jaw vise, two 1¼-20 nuts, and two 7/16 open end wrenches.

12. Remove the spring (9) from the valve stem (8).
13. Position the bellows/valve stem assembly in the vise with the valve stem pointed up and the seal disc between the jaws. Tighten the vise jaws on the seal disc periphery firmly but not so tight as to deform the seal disk (Figure 1-7).

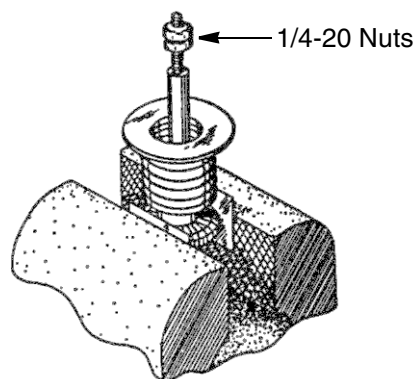

Figure 1-7 Removing the Stem from the Seal Disc

14. Thread both nuts to the midpoint of the threaded section of the stem. Using two wrenches, tighten the two nuts into each other by turning the bottom nut counterclockwise while simultaneously turning the top nut clockwise (Figure 1-7).

Block Valves: Instruction Manual for All Sizes

15. Turn the bottom nut counterclockwise using the wrench. The nuts should not rotate with respect to the stem, instead the stem rotates with respect to the seal disc. Continue turning the stem until it separates from the seal disc.
16. Remove the nuts from the stem (8).
17. Separate the remaining component: bellows and seal disc (11) by hand.
18. Using plastic tweezers or other non-destructive instrument, remove O-ring (12; 14) from the seal disc and the O-ring (13; 15) from the valve body.
19. Proceed to:
 - Step 20, if an air leak is suspected in the solenoid.
 - Otherwise, disassembly is complete.

CAUTION



When cleaning the parts of the bellows/stem assembly, wipe only the surface area of the bellows and seal disk exposed to the vacuum system. Soaking the bellows/stem assembly in an alcohol bath damages the O-ring (8) and causes it to outgas under vacuum.

20. Clean the metal components using an alcohol-dampened cloth or a light abrasive cloth such as Scotch-Brite™.
21. Wipe all surfaces with an alcohol-dampened cloth and allow components to dry thoroughly.

1.3.5.4 Reassembly

Refer to Figure 1-5 on page 1-11 for this procedure.

NOTE



In this procedure, the components (shown in Figure 1-5, identified in Table 1-5 and Table 1-6) are enclosed in parentheses, using the following convention:

- A single number or a series of numbers not separated by a semi-colon refer to both the small and large valve.*
- In a set of numbers separated by a semi-colon:
 - The first item number identifies an item in the small block valve.*
 - The second item number identifies an item in the large block valve.**

Block Valves: Instruction Manual for All Sizes

To reassemble the valve:



When completely rebuilding the valve, be sure to reassemble with new O-rings, quad ring, and cylinder cup.

1. Wipe all O-rings (12 and 13; 14 and 15) clean and very lightly grease them with Dupont Krytox[®] GPL207 vacuum lubricant.
2. Secure the bellows and seal disc (11; 11, 12 and 13) in a vise as described in disassembly procedures, step 13.
3. Place the O-ring (12 – large valve only) into its groove on the bellows and seal disc (11).
4. Place the washer (10) into the bellow and over the seal disc threaded stud (11; 13) with the stepped side facing up. This washer is used to center the spring on bellows assemblies without a boss machined into the seal disc.
5. Take the valve stem (8) in hand, apply Loctite[®] 242 adhesive to the first three female threads.
6. Thread the valve stem (8) onto the threaded rod of the seal disc (11) by turning the stem clockwise until finger-tight.
7. Place the spring (9) over the stem so it is seated on the special washer (10). This washer is required only in older model valves.
8. Proceed to:
 - Step 9 if resassembly of the air cylinder is necessary.
 - Step 15, if resassembly of the air cylinder is not required.
9. Lubricate the quad ring (7) liberally with Sta-lube 3120 grease. The piston cup (5) has a rubber-coated bottom surface and a metal upper surface (Figure 1-8). Apply Sta-lube liberally to the side walls and the rubber-coated bottom surface, leaving the metal top surface dry.

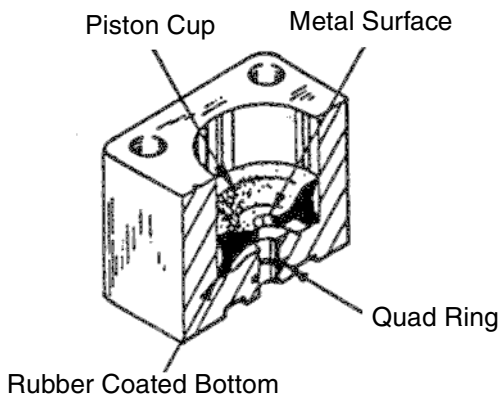

Figure 1-8 Position of Quad Ring In its Groove

10. Place the quad ring (7) in its groove.
11. Push the piston cup (5) into the air cylinder (6) with the rubber-coated side down.
12. Place the air cylinder (6) onto the valve stem (8) with the rubber side of the piston cup (5) facing up.
13. Thread the stop nut (4) onto the valve stem (8).
14. Using a torque wrench, torque the stop nut to 45 inch-pounds.
15. Push the red visual indicator cap (3) onto the valve stem (8).
16. Place the O-ring (13; 15) into its groove on the valve body.
17. Place the air cylinder/bellows assembly into the valve body.
18. Put the air cylinder cover (1) into position and secure the assembly with cap screws (2).
19. Mount the solenoid assembly to the air cylinder and tighten with a 5/8" open end wrench.

1.3.5.5 Position Indicator

This discussion details how to disassemble the position indicator so that:

- A defective microswitch can be fixed
(see "Replacing the Defective Microswitch" on page 1-21)

or

- A new position indicator can be installed using a kit
(see "Installing the Position Indicator Kit" on page 1-22).

In either case:

1. Disassemble the valve as explained in "Disassembly/Reassembly" on page 1-21.
2. Perform the procedure required.
3. Reassemble the valve as explained in "Disassembly/Reassembly" on page 1-21.
4. Once either procedure is complete, the switches can be tested (see "Test Procedure" on page 1-23).

Block Valves: Instruction Manual for All Sizes

Figure 1-9 shows an exploded view of the position indicator and Table 1-7 lists the associated callouts.

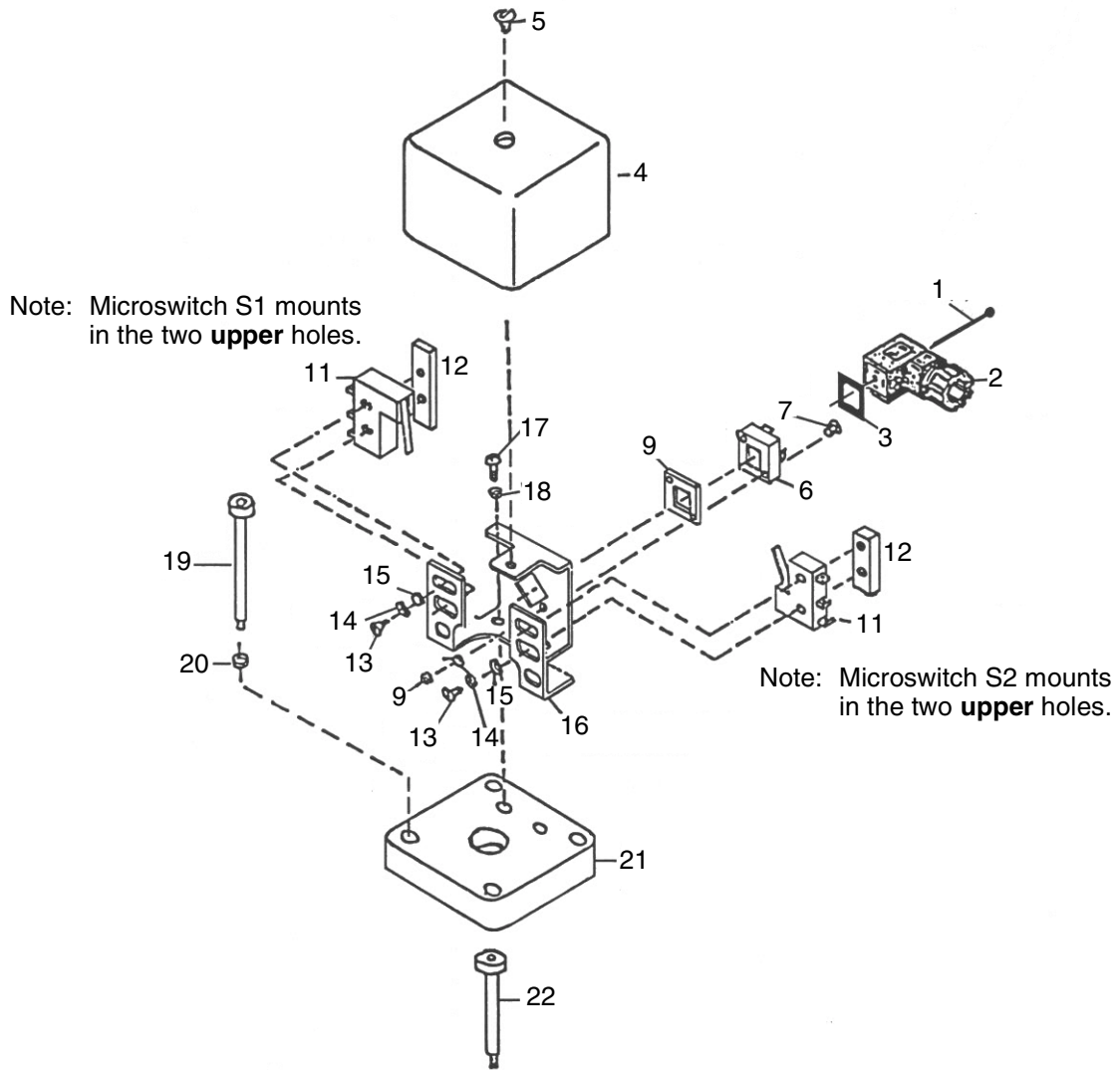

Figure 1-9 Position Indicator Assembly Exploded View

Block Valves: Instruction Manual for All Sizes

Table 1-7 Position Indicator Parts List

Item	Description	Vacuum Technologies Part No. or Equivalent
1	Holding Screw	Included with item 1
2	Connector	MPM 193-07N
3	Gasket	Included with item 1
4	Position Indicator Cover	L5978001
5	Screw, Phillips head	#6-32 x 1/4 lg
6	Connector Base	MPM 193
7	Screw, Phillips head	#2-56 x 3/8 lg
8	Gasket	Included with item 6
9	Nut	#2-56
10	Lockwasher	#2
11	Microswitch	Cherry E61-10H
12	Threaded Holder	Q3033001
13	Screw, Phillips head	#2-56 x 1/2 lg
14	Lockwasher	#2
15	Washer, Flat	#2
16	Microswitch Mounting Bracket	L8673301
17	Screw, Philips head	#6-32 x 1/4 lg
18	Lockwasher	#6
19	Screw, Allen head cap	#10-32 x 2 lg (NW16, NW25, NW50, ISO63) 1/4-20 x 2 lg (NW40, ISO80)
20	Lockwasher	No.10 (NW16, NW25, NW50, ISO63) 1/4" (NW40, ISO80)
21	Air Cylinder Cover, Aluminum	L5484001 (NW16, NW25)
		L5674001 (NW40)
		L6612001 (NW50, ISO63)
		L4474001 (ISO80)
22	Screw, Shoulder, 5/16 by 1/2", Stainless Steel	L8844001

1.3.5.5.1 Disassembly/Reassembly

Refer to Figure 1-9 on page 1-19 for this procedure:

1. Remove the holding screw (1) from the connector (2) and pull the connector off the connector base (6).
2. Remove the screw (5) from the position indicator cover (4) and lift the cover off the air cylinder cover (21).

The components of the position indicator are now accessible. To reassemble the valve, reverse the steps in the procedure above.

1.3.5.5.2 Replacing the Defective Microswitch

To replace the microswitch:

1. Disconnect the soldered leads from the Microswitch pins.
2. Unscrew the mounting screws (13) and remove the Microswitch (11).
3. Reassemble a new switch on the bracket (16) as shown in Figure 1-9 on page 1-19. Note the position of the switches on the bracket and wire the microswitches as shown in Figure 1-10 on page 1-23.
4. Solder the leads to the Microswitch. Leads are wired to the connector base as indicated in Table 1-8.

Table 1-8 Connector Base Wiring

Base Pin	Wire	Dual Microswitch
1	Orange	Switch 2, NO
2	Blue	Switch 1, NO
3	White	Switch 1 and 2, Common
	Green	Ground

1.3.5.5.3 Installing the Position Indicator Kit

To install a position indicator kit:

1. Remove the cover (4) from the position indicator assembly by removing the electrical connector and the screw and lockwasher from the top cover.
2. Apply air pressure to the valve and allow the valve to remain in the open position.
3. Remove the red visual indicator cap (not shown) from the valve stem.
4. Apply a small amount of Loctite #242 to the threads of the special shoulder screw (22) before threading it into the valve stem. Install the 5/16 by 1/2" long stainless steel shoulder screw on the valve stem. Tighten the shoulder screw until it is fully threaded into the valve stem then torque it to 30 inch-pounds.
5. Remove the air pressure from the valve to close it.
6. Carefully mount the position indicator assembly on the valve. It may be necessary to move the switches back to clear the shaft. Use two #6-32 x 3/4" pan head screws and two #6 lockwashers to fasten the position indicator on the top of the valve.

1.3.5.5.3.1 Wiring the Position Indicator

Refer to Figure 1-9 on page 1-19 for this procedure.

To wire the position indicator:

1. Remove the holding screw (1) and pull the connector (2) away from the base (6).
2. Using the holding screw, push the terminal block out of the connector housing.
3. Feed the No.22 AWG wire through the housing grommet and connect the leads to the appropriate terminal block contacts for the desired operation.



The position indicator can be wired for normally-open or normally-closed operation, or both:

Normally-open The position indicator supplies an electrical output signal when the valve is open.

Normally-closed The position indicator supplies a signal when the valve is closed.

Both A signal is supplied when the valve is open or closed.

- Wire terminal contacts as detailed in Figure 1-10.

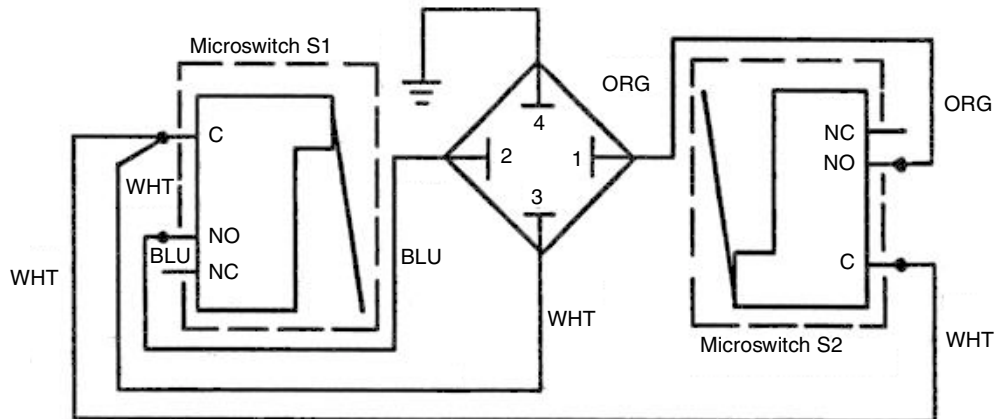

Figure 1-10 Wiring Diagram – Position Indicator

- Push the terminal block back into the connector housing and snap it into place.
- Plug the connector back into the base and secure it with the holding screw.

1.3.5.5.4 Test Procedure

Once a microswitch is replaced or a position indicator is installed, perform the test procedure for dual switches:

- Connect an Ohmmeter to pin 1 (orange wire, Figure 1-10) and pin S (white wire) of switch S2 connector, then set the meter to measure resistance (Ohms).
- With the valve in the open position (air pressure applied), adjust switch S2 (right side) until the Microswitch closes.
- Tighten the screws holding switch S2.
- Actuate the valve five times and ensure that the switch S2 opens and closes and is in the correct position.
- Close the valve by removing the air pressure from the valve.
- Connect the Ohmmeter to pin 2 (blue wire) and pin S (white wire) of the switch S1 connector. The meter should still be set to read resistance (Ohms).
- With the valve in the closed position (no air pressure), adjust switch S1 (left side) until the Microswitch closes.
- Apply air pressure to open the valve. Switch S1 should open. Readjust it if necessary by tightening the screws.
- Actuate the valve five times to ensure that the switch opens and closes and is in the correct position.
- Place the cover on the position indicator and replace the connector using the appropriate hardware.

This page intentionally left blank.

Appendix A. Technical Specifications

Table A-1 lists the block valve specifications.

Table A-1 Block Valve Specifications

	NW 16	NW 25	NW 40	NW 50	ISO 63	ISO 80
Conductance	3 liters/sec	12 liters/sec	32 liters/sec	61 liters/sec	100 liters/sec	155 liters/sec
Main Seal Leak Rate	$\leq 1 \times 10^{-9}$ std cc/sec Helium					
Body Leak Rate	$\leq 1 \times 10^{-10}$ std cc/sec Helium					
Materials						
Valve Body	Aluminum (6061-T6) or stainless steel					
Bellows	Stainless Steel T300 Series					
O-rings, vacuum	Viton V747-75					
Air Piston	Viton V747-75					
Baking Temperature						
Manual valve	80° C (176° F)			150° C (302° F)		
Pneumatic valve	80° C (176° F) without solenoid			150° C (302° F) without solenoid		
	60° C (140° F) with solenoid			60° C (140° F) with solenoid		
Miscellaneous						
Service Life Bellows	1,000,000 cycles					
Manual valve, number of turns to open (seated to fully open)	6			9		
Pneumatic Valve						
Air connection	1/8 NPT					
Air pressure	80 psig (minimum)					
	100 psig (minimum)					
Open/close time	<1 second					
Actuation	Spring closed, air opened					
Power loss	Valve closes					

Block Valves: Instruction Manual for All Sizes

Table A-1 Block Valve Specifications (Continued)

	NW 16	NW 25	NW 40	NW 50	ISO 63	ISO 80
Position Indicator						
Actuator	Microswitch					
Electrical rating	125/250 VAC, 5 A maximum					
Signal hookup	NO or NC or both					
Microswitch life	250,000 cycles with 1 A load					

Appendix B. Spare Parts Kits/Accessories and Replacement Parts

Table B-1 lists the spare part kits by valve type.

Table B-1 Spare Part Kits

Valve Type	Valve	Part No.
Manual	NW 16 or NW 25*	L6125301
	NW 40*	L6126301
	NW 50**	L6625301
	ISO 63**	L7276301
	ISO 80**	L7278301
*Includes: Bellows, Stem, Stem nut, and O-rings **Includes: Bellows assembly, and O-rings		
Pneumatic	NW 16 or NW 25	L6127301
	NW 40	L6128301
	NW50	L6615301
	ISO 63	L7277301
	ISO 80	L7279301
Includes: Quad ring, Bellows, all O-rings, and Lubricant		

Table B-2 on page B-2 lists the accessories and replacement parts by valve type.

Block Valves: Instruction Manual for All Sizes

Table B-2 KF Clamp® and Centering Ring Ordering Information

KF Fitting	KF Clamp with Ratchet Closure Part No.	Centering Ring with Viton O-ring Part No.
NW16	KQ16AR	KC16SV
NW25	KQ25AR	KC25SV
NW40	KQ40AR	KC40SV
NW50	KQ50AR	KC50SV
ISO63	IC063100A	IC063AV
ISO80	IC063100A	IC80AV
Dupont Krytox® GPL207 Vacuum Grease		695400010
Sta-lube bearing grease		3120



*Request for Return
Health and Safety Certification*



- Return authorization numbers (RA#) **will not** be issued for any product until this Certificate is completed and returned to a Varian, Inc. Customer Service Representative.
- Pack goods appropriately and drain all oil from rotary vane and diffusion pumps (for exchanges please use the packing material from the replacement unit), making sure shipment documentation and package label clearly shows assigned Return Authorization Number (RA#) VVT cannot accept any return without such reference.
- Return product(s) to the nearest location:

North and South America
 Varian, Inc.
 Vacuum Technologies
 121 Hartwell Ave.
 Lexington, MA 02421
 Fax: (781) 860-9252

Europe and Middle East
 Varian S.p.A.
 Via F.lli Varian, 54
 10040 Leini (TO) – ITALY
 Fax: (39) 011 997 9350

Asia and ROW
 Varian Vacuum Technologies
 Local Office

For a complete list of phone/fax numbers see www.varianinc.com/vacuum

- If a product is received at Varian, Inc. in a contaminated condition, **the customer is held responsible** for all costs incurred to ensure the safe handling of the product, and **is liable** for any harm or injury to Varian, Inc. employees occurring as a result of exposure to toxic or hazardous materials present in the product.

CUSTOMER INFORMATION

Company name:

Contact person: Name: Tel:.....
 Fax: E-mail:

Ship method: Shipping Collect #: P.O.#:

Europe only: VAT Reg Number: USA only: Taxable Non-taxable

Customer ship to: Customer bill to:

.....

.....

PRODUCT IDENTIFICATION

Product Description	Varian, Inc. Part Number	Varian, Inc. Serial Number

TYPE OF RETURN (check appropriate box)

<input type="checkbox"/> Paid Exchange	<input type="checkbox"/> Paid Repair	<input type="checkbox"/> Warranty Exchange	<input type="checkbox"/> Warranty Repair	<input type="checkbox"/> Loaner Return
<input type="checkbox"/> Credit	<input type="checkbox"/> Shipping Error	<input type="checkbox"/> Evaluation Return	<input type="checkbox"/> Calibration	<input type="checkbox"/> Other

HEALTH and SAFETY CERTIFICATION

VACUUM TECHNOLOGIES CANNOT ACCEPT ANY BIOLOGICAL HAZARDS, RADIOACTIVE MATERIAL, ORGANIC METALS, OR MERCURY AT ITS FACILITY. CHECK ONE OF THE FOLLOWING:

I confirm that the above product(s) has (have) **NOT** pumped or been exposed to any toxic or dangerous materials in a quantity harmful for human contact.

I declare that the above product(s) has (have) pumped or been exposed to the following toxic or dangerous materials in a quantity harmful for human contact (Must be filled in):

Print Name..... Signature Date

PLEASE FILL IN THE FAILURE REPORT SECTION ON THE NEXT PAGE

Do not write below this line

Notification (RA) #: Customer ID #: Equipment #:.....



FAILURE REPORT

(Please describe in detail the nature of the malfunction to assist us in performing failure analysis):

TURBO PUMPS AND TURBOCONTROLLERS

Claimed Defect	Position	Parameters
<input type="checkbox"/> Does not start <input type="checkbox"/> Does not spin freely <input type="checkbox"/> Does not reach full speed <input type="checkbox"/> Mechanical Contact <input type="checkbox"/> Cooling defective <input type="checkbox"/> Noise <input type="checkbox"/> Vibrations <input type="checkbox"/> Leak <input type="checkbox"/> Overtemperature <input type="checkbox"/> Clogging	<input type="checkbox"/> Vertical <input type="checkbox"/> Horizontal <input type="checkbox"/> Upside-down <input type="checkbox"/> Other:	Power: Rotational Speed: Current: Inlet Pressure: Temp 1: Foreline Pressure: Temp 2: Purge flow: Operation Time:
Describe Failure:		
Turbocontroller Error Message:		

ION PUMPS/CONTROLLERS

<input type="checkbox"/> Bad feedthrough <input type="checkbox"/> Vacuum leak <input type="checkbox"/> Error code on display <input type="checkbox"/> Poor vacuum <input type="checkbox"/> High voltage problem <input type="checkbox"/> Other
Describe failure:
Customer application:

VALVES/COMPONENTS

<input type="checkbox"/> Main seal leak <input type="checkbox"/> Solenoid failure <input type="checkbox"/> Damaged sealing area <input type="checkbox"/> Bellows leak <input type="checkbox"/> Damaged flange <input type="checkbox"/> Other
Describe failure:
Customer application:

LEAK DETECTORS

<input type="checkbox"/> Cannot calibrate <input type="checkbox"/> Vacuum system unstable <input type="checkbox"/> Failed to start <input type="checkbox"/> No zero/high background <input type="checkbox"/> Cannot reach test mode <input type="checkbox"/> Other
Describe failure:
Customer application:

INSTRUMENTS

<input type="checkbox"/> Gauge tube not working <input type="checkbox"/> Communication failure <input type="checkbox"/> Error code on display <input type="checkbox"/> Display problem <input type="checkbox"/> Degas not working <input type="checkbox"/> Other
Describe failure:
Customer application:

ALL OTHER VARIAN, INC.

<input type="checkbox"/> Pump doesn't start <input type="checkbox"/> Doesn't reach vacuum <input type="checkbox"/> Pump seized <input type="checkbox"/> Noisy pump (describe) <input type="checkbox"/> Overtemperature <input type="checkbox"/> Other
Describe failure:
Customer application:

DIFFUSION PUMPS

<input type="checkbox"/> Heater failure <input type="checkbox"/> Doesn't reach vacuum <input type="checkbox"/> Vacuum leak <input type="checkbox"/> Electrical problem <input type="checkbox"/> Cooling coil damage <input type="checkbox"/> Other
Describe failure:
Customer application:

Sales and Service Offices

Argentina

Varian Argentina Ltd.

Sucursal Argentina
Av. Ricardo Balbin 2316
1428 Buenos Aires
Argentina
Tel: (54) 1 783 5306
Fax: (54) 1 786 5172

Benelux

Varian Vacuum Technologies

Rijksstraatweg 269 H,
3956 CP Leersum
The Netherlands
Tel: (31) 343 469910
Fax: (31) 343 469961

Brazil

Varian Industria e Comercio Ltda.

Avenida Dr. Cardoso de Mello 1644
Vila Olimpia
Sao Paulo 04548 005
Brazil
Tel: (55) 11 3845 0444
Fax: (55) 11 3845 9350

Canada

Central coordination through:

Varian Vacuum Technologies
121 Hartwell Avenue
Lexington, MA 02421
USA
Tel: (781) 861 7200
Fax: (781) 860 5437
Toll Free: (800) 882 7426

China

Varian Technologies - Beijing

Room 1201, Jinyu Mansion
No. 129A, Xuanwumen Xidajie
Xicheng District
Beijing 1000031 P.R. China
Tel: (86) 10 6641 1530
Fax: (86) 10 6641 1534

France and Wallonie

Varian s.a.

7 avenue des Tropiques
Z.A. de Courtaboeuf – B.P. 12
Les Ulis cedex (Orsay) 91941
France
Tel: (33) 1 69 86 38 13
Fax: (33) 1 69 28 23 08

Germany and Austria

Varian Deutschland GmbH

Alsfelder Strasse 6
Postfach 11 14 35
64289 Darmstadt
Germany
Tel: (49) 6151 703 353
Fax: (49) 6151 703 302

India

Varian India PVT LTD

101-108, 1st Floor
1010 Competent House
7, Nangal Raya Business Centre
New Delhi 110 046
India
Tel: (91) 11 5548444
Fax: (91) 11 5548445

Italy

Varian Vacuum Technologies

Via F.lli Varian, 54
10040 Leini, (Torino)
Italy
Tel (39) 011 997 9 111
Fax (39) 011 997 9 350

Japan

Varian Vacuum Technologies

Sumitomo Shibaura Building, 8th Floor
4-16-36 Shibaura
Minato-ku, Tokyo 108
Japan
Tel: (81) 3 5232 1253
Fax: (81) 3 5232 1263

Korea

Varian Technologies Korea, Ltd.

Shinsa 2nd Building 2F
966-5 Daechi-dong
Kangnam-gu, Seoul
Korea 135-280
Tel: (82) 2 3452 2452
Fax: (82) 2 3452 2451

Mexico

Varian S.A.

Concepcion Beistegui No 109
Col Del Valle
C.P. 03100
Mexico, D.F.
Tel: (52) 5 523 9465
Fax: (52) 5 523 9472

Taiwan

Varian Technologies Asia Ltd.

14F-16 No.77, Hsin Tai Wu Road Sec. 1,
Hsi Chih, Taipei Hsien
Taiwan, R.O.C.
Tel: (886) 2 2698 9555
Fax: (886) 2 2698 9678

UK and Ireland

Varian Ltd.

28 Manor Road
Walton-On-Thames
Surrey KT 12 2QF
England
Tel: (44) 1932 89 8000
Fax: (44) 1932 22 8769

United States

Varian Vacuum Technologies

121 Hartwell Avenue
Lexington, MA 02421
USA
Tel: (781) 861 7200
Fax: (781) 860 5437
Toll Free: (800) 882 7426

Other Countries

Varian Vacuum Technologies

Via F.lli Varian, 54
10040 Leini, (Torino)
Italy
Tel: (39) 011 997 9111
Fax: (39) 011 997 9350

Internet Users:

Customer Service and Technical Support:

vpl.customer.support@varianinc.com

Worldwide Web Site:

www.varianinc.com/vacuum

Order On-line:

www.evarian.com

Representatives in most countries



VARIAN

