

Rotary Vane Vacuum Pumps **SD Series**

2005SD 2010SD
2015SD 2021SD

PASCAL Series **adixen** **ALCATEL**

2005SD CFM 3.8
2010SD CFM 6.8
2015SD CFM 10.6
2121SD CFM 14.6

Alcatel Adixen Pascal Series 2005SD - 2010SD - 2015SD - 2021SD
2 Stage Rotary Vane Vacuum Pump

REBUILT

From 3.8 to 14.6 CFM

- **compact design** : reduced dimensions, choice of horizontal or vertical inlet and exhaust ports, all controls and service access located on the front.
- **optimized tightness** : integrated anti-suckback ; all static sealings secured by O-rings; external shaft seal can be renewed easily, without dismantling the pump.
- **high pumping speed** from atmosphere to vacuum.
- **efficient gas ballast** for vapor pumping.
- **air cooled** for optimum performance
- **field serviceable** using the appropriate maintenance kits



SD Series rotary vane pumps address the requirements of all major vacuum applications in diverse industries.

SD 2005-21 PASCAL Series 2 Stages

Specifications		Units	2005SD	2010SD	2015SD	2021SD
Part Number			P101552	P101553	P101554	P101555
Rebuilt Pump Price (2008 List Prices)			\$1,250.00	\$1,450.00	\$1,650.00	\$1,850.00
Nominal pumping speed	50Hz	m ³ /h	5.4	9.7	15	20.7
	60Hz	cfm	3.8	6.8	10.6	14.6
Pneurop pumping speed	50Hz	m ³ /h	4.8	8.5	12	15.5
	60Hz	cfm	3.4	6	8.8	11.8
Ultimate partial pressure		mbar	10 ⁻⁴	10 ⁻⁴	10 ⁻⁴	10 ⁻⁴
Ultimate total pressure closed gas ballast		mbar	2.10 ⁻³	2.10 ⁻³	2.10 ⁻³	2.10 ⁻³
Ultimate total pressure open gas ballast		mbar	10 ⁻²	10 ⁻²	10 ⁻²	10 ⁻²
Water vapor capacity	50/60Hz	g/h	120/110	125/100	110/100	90/90
Water vapor pressure	50/60Hz	mbar	35/25	20/15	12/10	7/7
Weight (max)		kg (lbs)	25 (55)	26 (57.2)	27 (59.4)	28 (61.6)
Pump Dimensions		BackPage	BackPage	BackPage	BackPage	BackPage
Electrical motors Universal 1 or 3 phase		3 phase 342V to 460V 50hz, 342V to 520V 60hz, 170V to 254V 50hz, 170V to 300V 60hz 1 phase 180V to 254V 50/60hz, 90V to 132V 50/60hz				
Max nominal power rating	50/60Hz	kW	0.45/0.55	0.45/0.55	0.45/0.55	0.45/0.55
Min ambient temperature		°C (°F)	12 (54)	12 (54)	12 (54)	12 (54)
Max ambient temperature		°C (°F)	45 (113)	45 (113)	45 (113)	45 (113)
Oil capacity		l	0.83	0.95	0.95	0.98
Inlet flange		ISO-KF	DN 25	DN 25	DN 25	DN 25
Exhaust flange		ISO-KF	DN 25	DN 25	DN 25	DN 25



[To Our Website](http://idealvac.com)
idealvac.com

Ideal Vacuum Products, LLC
2401B Phoenix Ave. NE
Albuquerque, NM 87107
Phone: (505) 872-0037
idealvac.com or pchemlabs.com

Dimensions for SD Series Vacuum Pumps

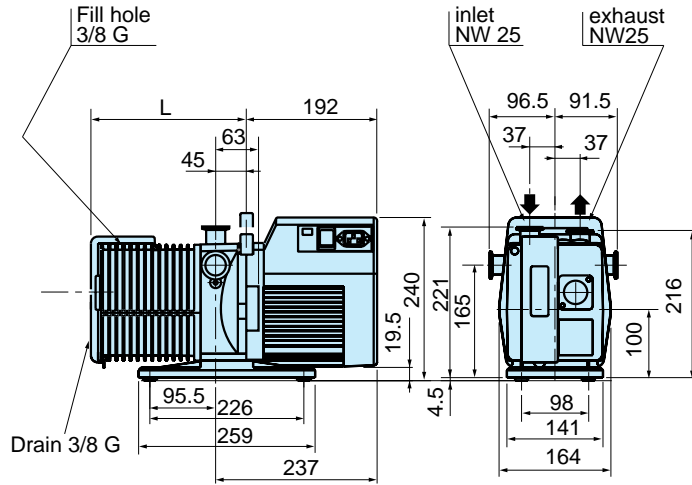

Specific Dimensions in mm	
SD Series	L mm
2005SD	228
2010SD	245
2015SD	270
2021SD	291

*same dimensions for single and three-phase motors

Accessories for SD Series vacuum pumps

- Reducer KF25 to KF16**
P/N P101263 \$74.55
- KF25 Half Nipple**
P/N P101218 \$14.25
- KF25 Full Nipple**
P/N P101234 \$39.90
- KF25 Toggle Clamp**
P/N P101639 \$15.45
- Alcatel 119 Oil**
P/N P102101 1 Quart \$14.60
P/N P102102 1 Gallon \$29.00
- 1 inch PVC Hose**
P/N P101639 Per ft. \$6.00

Other Varieties & Sizes Available

Oil Mist Exhaust Filters KF/NW25

Oil Mist Exhaust Filters retain oil mist contained in the exhausted gases with a high level of separation.

- Up to 10 CFM for 2005, 2010SD**
P/N P102027 \$143.00
Replacement Cartridge
P/N GL915 \$27.00
- Up to 16 CFM for 2005-2021SD**
P/N P102028 \$226.00
Replacement Cartridge
P/N FG9 \$30.60
- Up to 20 CFM for 2005-2021SD**
P/N P102029 \$315.00
Replacement Cartridge
P/N EEPS6925 \$54.00
- Up to 24 CFM for 2005-2021SD**
P/N P101878 \$165.00
Replacement Cartridge
P/N P101882 \$44.00

(All Filters come With Media)

Alcatel, Adixen, Oil Mist Eliminators (OME)

Oil Mist Eliminators retain oil mist contained in the exhausted gases with a high level of separation; an internal over pressure valve prevents exceeding the maximum exhaust pressure.

- OME 25S**
Inlet NW/KF25 for 2005SD thru 2021SD
P/N P102596 \$228.00
Replacement Cartridge
P/N P102593 \$18.75
Comes with centering ring, 1 clamp and angle port
- OME 25 HP**
For Frequent Recycling or High Pressure Operation
Inlet NW/KF25 for 2015SD and 2021SD
P/N P102597 \$439.20
Replacement Cartridge
P/N P102594 \$25.20
Comes with centering ring and 1 clamp



To Our Website
idealvac.com

Alcatel, Adixen, Inlet Dust Filter

Inlet Dust Filters will prevent solid particles from entering into the rotary vane pump and avoid concentration of solid media which can act as an abrasive and shorten the pump life.

- DFT 25**
Inlet NW/KF25 for 2005SD thru 2021SD
P/N 104202 \$276.00
Replacement Cartridge
P/N 068445 \$46.05
Comes with centering ring, 1 clamp and angle port

Ideal Vacuum Products, LLC
2401B Phoenix Ave. NE
Albuquerque, NM 87107
Phone: (505) 872-0037
idealvac.com or pchemlabs.com

Rev. 1mar 2009