

Rotary Vane Vacuum Pumps C1 Series

2005C1 2010C1 2015C1 2021C1 PASCAL Series **adixen**

By PFEIFFER VACUUM

2005C1 CFM 3.8
2010C1 CFM 6.8
2015C1 CFM 10.6
2121C1 CFM 14.6

Alcatel Adixen Pascal Series 2005C1 - 2010C1 - 2015C1 - 2021C1

2 Stage Rotary Vane Vacuum Pump

Designed for **CORROSION PROTECTION**

- **compact design** : reduced dimensions, choice of horizontal or vertical inlet and exhaust ports, all controls and service access located on the front.
- **optimized tightness** : integrated anti-suckback ; all static sealings secured by O-rings; external shaft seal can be renewed easily, without dismantling the pump.
- **high pumping speed** from atmosphere to vacuum.
- **efficient gas ballast** for vapor pumping.
- **air cooled** for optimum performance
- **field serviceable** using the appropriate maintenance kits



C1 Series Designed for pumping **corrosive or aggressive gases in the chemical industry and R&D**, meeting strict requirements with regards to material compatibility and corrosion resistance.

Prepared with **A200 Adixen Oil NO PFPE**

C1 2005-21 PASCAL Series 2 Stages

Specifications		Units	2005C1	2010C1	2015C1	2021C1
Part Number			P102365	P102366	P102367	P102376
Price (CALL)						
Nominal pumping speed	50Hz	m ³ /h	5.4	9.7	15	20.7
	60Hz	cfm	3.8	6.8	10.6	14.6
Pneurop pumping speed	50Hz	m ³ /h	4.8	8.5	12	15.5
	60Hz	cfm	3.4	6	8.8	11.8
Ultimate partial pressure		mbar	10 ⁻⁴	10 ⁻⁴	10 ⁻⁴	10 ⁻⁴
Ultimate total pressure closed gas ballast		mbar	2.10 ⁻³	2.10 ⁻³	2.10 ⁻³	2.10 ⁻³
Ultimate total pressure open gas ballast		mbar	10 ⁻²	10 ⁻²	10 ⁻²	10 ⁻²
Water vapor capacity	50/60Hz	g/h	120/110	125/100	110/100	90/90
Water vapor pressure	50/60Hz	mbar	35/25	20/15	12/10	7/7
Weight (max)		kg (lbs)	25 (55)	26 (57.2)	27 (59.4)	28 (61.6)
Pump Dimensions		BackPage	BackPage	BackPage	BackPage	BackPage
Electrical motors Universal 1 or 3 phase		3 phase 342V to 460V 50hz, 342V to 520V 60hz, 170V to 254V 50hz, 170V to 300V 60hz 1 phase 180V to 254V 50/60hz, 90V to 132V 50/60hz				
Max nominal power rating	50/60Hz	kW	0.45/0.55	0.45/0.55	0.45/0.55	0.45/0.55
Min ambient temperature		°C (°F)	12 (54)	12 (54)	12 (54)	12 (54)
Max ambient temperature		°C (°F)	45 (113)	45 (113)	45 (113)	45 (113)
Oil capacity		l	0.83	0.95	0.95	0.98
Inlet flange		ISO-KF	DN 25	DN 25	DN 25	DN 25
Exhaust flange		ISO-KF	DN 25	DN 25	DN 25	DN 25



To Our Website
ideallvac.com

Ideal Vacuum Products, LLC
5910 Midway Park Blvd. NE
Albuquerque, NM 87109
Phone: (505) 872-0037
ideallvac.com or pchemlabs.com

Dimensions for C1 Series Vacuum Pumps

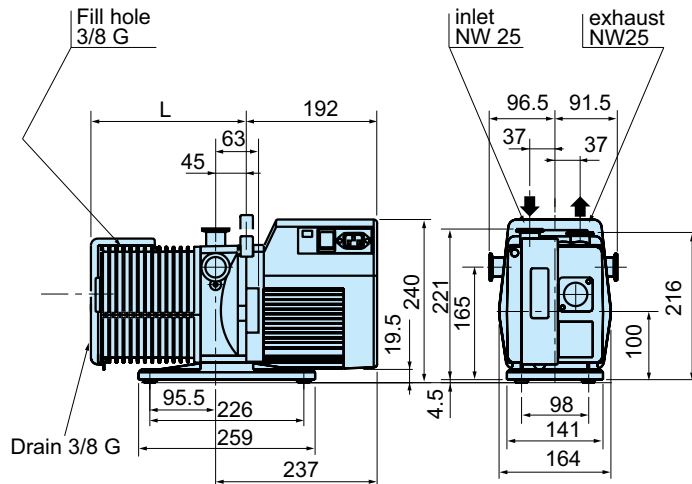

Specific Dimensions in mm	
C1 Series	L mm
2005	228
2010	245
2015	270
2021	291

*same dimensions for single and three-phase motors

Accessories for C1 Series vacuum pumps

DE External Filter



DE FILTERS retain solid particles and/or neutralizes corrosive products contained in the oil of the pump. DE filters can be connected to any rotary vane pump from 5 m³/h to 100 m³/h; all necessary components for connexion are included.

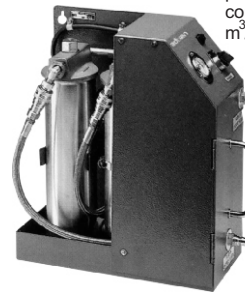

DE Filter Media DE1

- **Cellulose filter:** filtration of solid particles only
Applications: General Use
- **Activated alumina:** envelope/charge of activated alumina
Applications: mineral acids, Lewis acids, Polar compounds.
- **Activated charcoal:** envelope/charge of activated charcoal.
Applications: Chlorinated products, water and chlorine, Nitrous vapors, Ammonia.

● DE External Filter DE1

weight kg/lbs	12/24.6
electrical supply	110/220V 50HZ
oil flow hydrocarbon	1000 - 1500 cm ³
synthetic	1000 cm ³ /mn at 65° C
P/N 110/115V	068991
220/230V	068990

● Replacement Cartridges

type	activated alumina	activated charcoal	cellulose
P/N	068880	068881	078212

standard (factory installed) cartridges are:
DE 1 : activated alumina
oil volume : DE 1: 1.2 lit.

Alcatel, Adixen, Oil Mist Eliminator For Corrosive Gases **adixen** **ALCATEL**

OME 25 C/H

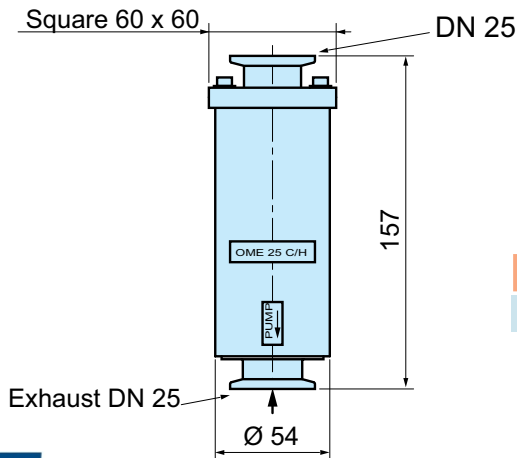

For applications involving corrosive gases or high level of tightness.

material:..... body : stainless steel
..... cartridge : PTFE/glass micro-fiber
weight:..... 0.530 kg 1.77 lbs
leak rate: ≤2.10⁻⁷ mbar l/s
inlet port/exhaust port: DN25 ISO-KF

P/N: 066849 Price:CALL

replacement cartridge: P/N 066800 for single Price:CALL

Orders must be placed for quantities multiple of 5 (5, 10, 15...).

supplied with: 1 centering ring and 1 clamp



[To Our Website](http://idealvac.com)
idealvac.com

2
Ideal Vacuum Products, LLC
5910 Midway Park Blvd. NE
Albuquerque, NM 87109
Phone: (505) 872-0037
idealvac.com or pchemlabs.com