



## Oil mist filter

ONF 16

ONF 25/25L/25XL

# ACCESSORY

## Table of contents

<b>1</b>	<b>About this manual</b> . . . . .	<b>3</b>
1.1	Validity . . . . .	3
1.2	Conventions . . . . .	3
<b>2</b>	<b>Safety</b> . . . . .	<b>4</b>
2.1	Safety precautions . . . . .	4
<b>3</b>	<b>Transport and storage</b> . . . . .	<b>5</b>
3.1	Storage . . . . .	5
<b>4</b>	<b>Product description</b> . . . . .	<b>5</b>
4.1	Product identification . . . . .	5
4.2	Function . . . . .	6
<b>5</b>	<b>Installation</b> . . . . .	<b>7</b>
5.1	Assembly . . . . .	7
5.2	Installing the oil return line. . . . .	8
<b>6</b>	<b>Operation</b> . . . . .	<b>9</b>
<b>7</b>	<b>Maintenance</b> . . . . .	<b>10</b>
7.1	Draining the operating fluid . . . . .	10
7.2	Changing and cleaning the filter insert . . . . .	11
<b>8</b>	<b>Service</b> . . . . .	<b>13</b>
<b>9</b>	<b>Accessories</b> . . . . .	<b>14</b>
<b>10</b>	<b>Technical data</b> . . . . .	<b>14</b>
10.1	Dimensions . . . . .	15
<b>11</b>	<b>Spare parts</b> . . . . .	<b>16</b>
11.1	Spare parts packages . . . . .	16
<b>12</b>	<b>Disposal</b> . . . . .	<b>17</b>

# 1 About this manual

## 1.1 Validity

This operating manual is for customers of Pfeiffer Vacuum. It describes the functioning of the designated product and provides the most important information for safe use of the unit. The description follows applicable EU guidelines. All information provided in this operating manual refer to the current state of the product's development. The documentation remains valid as long as the customer does not make any changes to the product.

Up-to-date operating instructions can also be downloaded from [www.pfeiffer-vacuum.net](http://www.pfeiffer-vacuum.net).

## 1.2 Conventions

### Safety instructions

The safety instructions in Pfeiffer Vacuum operating manuals are the result of risk evaluations and hazard analyses and are oriented on international certification standards as specified by UL, CSA, ANSI Z-535, Semi-S1, ISO 3864 and DIN 4844. In this document, the following hazard levels and information are considered:

<b>DANGER</b>	
<b>Immediate danger</b>	Death or very severe injuries occur.
<b>WARNING</b>	
<b>Possible danger</b>	Death or injuries may occur.
<b>CAUTION</b>	
<b>Possible danger</b>	Medium to slight injuries may occur.
<b>NOTE</b>	
<b>Command or note</b>	Command to perform an action or information about properties, the disregarding of which may result in damage to the product.

### Pictogram definitions



Prohibition of an action or activity in connection with a source of danger, the disregarding of which may result in serious accidents.



Warning of a displayed source of danger in connection with operation of the unit or equipment.



Command to perform an action or task associated with a source of danger, the disregarding of which may result in serious accidents.

**Instructions in the text**

→ Work instruction: here you have to do something.

**Abbreviations used**

**ONF:** Oil Mist Filter

**ORF:** Oil Return Device

## 2 Safety

### 2.1 Safety precautions



NOTE
<p><b>Duty to inform</b></p> <p>Each person involved in the installation, operation or maintenance of the vacuum pump must read and observe the safety-related parts of these operating instructions.</p> <p>→ The operator is obligated to make operating personnel aware of dangers originating from the vacuum pump, the pumped medium and the entire system.</p>

→ Vor allen Arbeiten die Betriebsanleitung und Sicherheitshinweise zum Pumpstand und den Einzelkomponenten lesen und beachten.

→ Connection to pumps or units which are not suitable for this purpose according to their operating instructions.

→ Connection to units which have exposed voltage-carrying parts.

→ Observe the safety and accident prevention regulations.

→ Check regularly that all safety precautions are being complied with.

→ When returning the components to us please note the instructions in the Service section.

→ The use of accessories, which are not named in this manual.

## 3 Transport and storage

### 3.1 Storage

The ONF should be stored dry and protected from moisture. The filter inserts can absorb moisture, and the lubrication properties of the oil and hence the end pressure can be negatively influenced in pumps with an oil return unit.

## 4 Product description

### 4.1 Product identification

To correctly identify the product when communicating with Pfeiffer Vacuum, always have the information from the rating plate available.

- Model and model number
- Date of manufacture



**Fig. 1: Product identification on the rating plate (example)**

### Variants

Type	Connection nominal diameter	intended for pump type
ONF 16	DN 16 ISO-KF	UNO 2.5, UNO 5, DUO 2.5, DUO 5 M
ONF 25	DN 25 ISO-KF	DUO 10 M, Penta 10
ONF 25L	DN 25 ISO-KF	UNO 30, DUO 20 M, Penta 20, TWIN 20-10
ONF 25XL	DN 25 ISO-KF	Penta 35

Connection nominal diameter

## 4.2 Function

The oil mist filter is mounted on the exhaust connection of rotary vane pumps. It prevents air pollution from operating fluid mist that is ejected by the pump to a greater or lesser degree depending on the operating pressure.

The filter inserts are installed in a housing made of corrosion-resistant aluminum and consist of a cylindrical filter of glass polyester fleece. The filter inserts are opened by an incorporated pressure relief valve when the contamination becomes excessive so that the maximum working pressure of 1.5 bar (absolute) cannot be exceeded. The collected operating fluid can be observed through a sightglass and discharged with a drain screw.

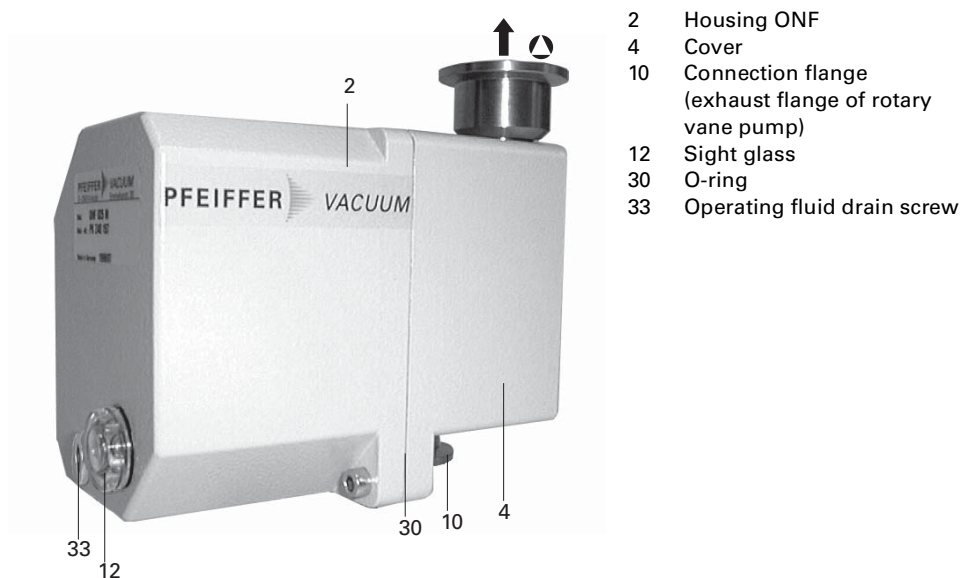

**Fig. 2: ONF 16/25/25 L**

### Operating fluid return line

An oil return unit ORF (optional) can be used to return collected operating fluid from the ONF automatically to the pump automatically without interrupting the pump.

## 5 Installation

### 5.1 Assembly

To install the ONF in a vacuum system, an ISO small flange or ISO clamp flanges are provided on the input side and output side. The flanges are provided with protective caps when delivered to protect the seals.

If gases are pumped that may not enter the atmosphere, an exhaust line must be connected to the exhaust flange.

If large amounts of vapour arise during operation, it is recommendable to install a condensate separator between the rotary vane pump and ONF so that condensate is removed in the KAS, and only oil mist enters the ONF.



#### WARNING

##### **Poisonous substances exit from the exhaust!**

There is a poisoning hazard from discharged gases or vapours that can be hazardous and/or polluting during use.

- Install and run the exhaust line so that overpressure cannot build up inside it.
- Follow the vacuum pump installation instructions in the respective operating instructions.



#### NOTE

##### **The filter inserts can become gummed!**

When pumping off gases and vapours that can polymerise, the filter inserts in the ONF can become gummed.

- Install a condensate separator upstream from the ONF.
- Remove the protective caps from the connection flanges.
- Place the ONF on the exhaust side of the rotary vane pump with the sightglass facing downward, and fasten it with the clamping ring (accessory) or bracket screws (accessory) if clamp flanges are used.

## 5.2 Installing the oil return line

An oil return unit ORF (optional) can be used to return collected operating fluid from the ONF automatically to the pump automatically without interrupting the pump.

- ONF 16/25/25 L**
- Unscrew operating fluid drain screw 33.
  - Drain off operating fluid if so and fill in the pump.
  - Screw in hose nipple 241 in place of the operating fluid drain screw; take care with O-ring.
  - Remove gas ballast valve 42 from the pump and absorb the operating fluid underneath.
  - Re-fit the gas ballast valve with intermediate flange 46 and screw tight with longer screws; take care with O-ring 148.
  - Screw fitting 240 into intermediate flange 46; take care with O-ring 138.
  - Fit operating fluid return hose 242 at both sides on the hose nipples and tighten with hose clip 243 at the ONF side.
  - Tighten the union nut of the fitting 240.

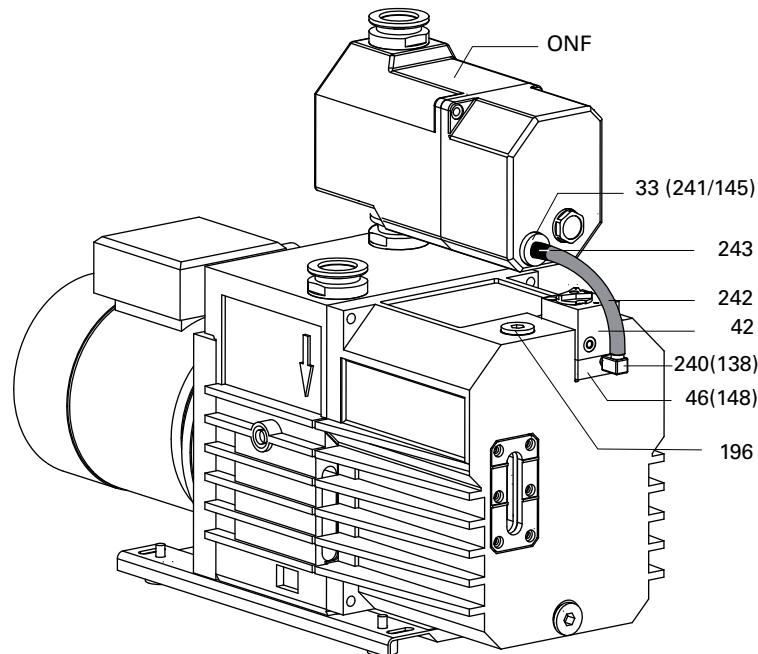
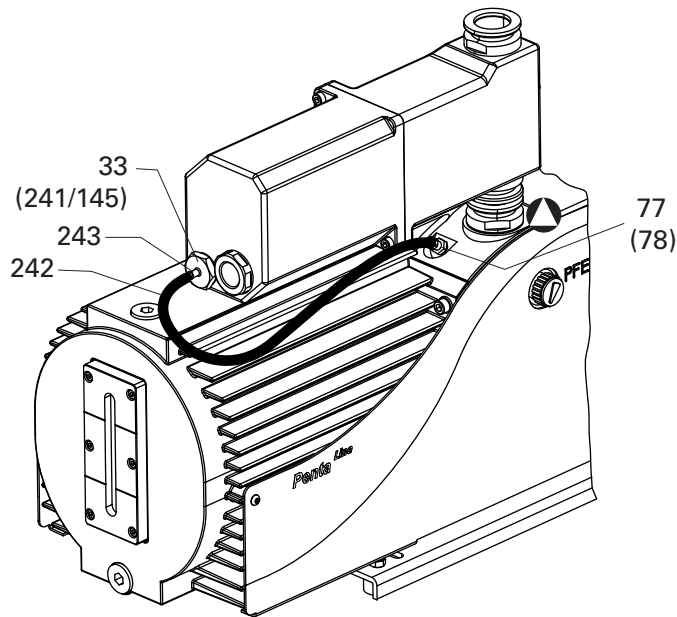

**Fig. 3: DUO Rotary vane pump with ONF and operating fluid return line**

33	Operating fluid drain screw	145	O-ring	242	Operating fluid re-
42	Gas ballast valve	240	Swiveling screw-fitting	turn line	
46	Intermediate flange	241	Hose nipple	243	Hose clip

- ONF 25 XL**
- Unscrew operating fluid drain screw 33.
  - Drain off operating fluid if so and fill in the pump.
  - Screw in hose nipple 241 in place of the operating fluid drain screw; take care with O-ring.
  - Unscrew and remove the union nut of the screw fitting 77 and remove the sealing plug 78.
  - Fit operating fluid return hose 242 at both sides on the hose nipples and tighten with hose clip 243 at the ONF side.
  - Tighten the union nut of the screw fitting 77.





**Fig. 4: PentaLine pump with ONF and Operating fluid return line**

33	Operating fluid drain screw	145	O-ring	242	Operating fluid return line
77	Screw fitting	241	Hose nipple	243	Hose clip
78	Sealing plug				

## 6 Operation



### NOTE

**Make sure that the return for the operating fluid works.**

Operating fluid is only sucked in and returned from an operating pressure of < 100 mbar and starting from a minimum quantity of operating fluid in the ONF.

→ Top up with operating fluid in order to ensure the return of operating fluid at the start of the evacuation phase.

→ Long evacuation phases with a high intake pressure should always be followed by operating phases with a lower operating pressure.



### NOTE

**Damage to the pump as a result of condensation in the operating fluid.**

Condensation caused by steam or by temperature differences between the ONF and the pump will impair the quality of the operating fluid after it is returned to the pump.

→ The operating fluid should be drained in good time if it starts to accumulate condensation.

## 7 Maintenance

### 7.1 Draining the operating fluid

If the accumulated operating fluid in the ONF is above the top edge of the sight-glass 12, the operating fluid must be drained.

The intervals at which the operating fluid is drained depends on the operating conditions.



#### WARNING

##### **Operating fluid may contain toxic substances from the pumped media!**

Danger of poisoning from the emission of harmful substances from the operating fluid.

- Wear suitable protective clothing and respirators.
- Dispose of operating fluid according to the local regulations



#### WARNING

##### **Toxic vapours!**

Danger of poisoning when igniting and heating synthetic operating fluids (e.g. F4/F5) above 300°C.

- Observe the application instructions of the operating fluid manufacturer.
- Do not allow operating fluid to make contact with tobacco products; observe safety precautions when handling chemicals.

- Screw out the operating fluid drain screw 33; pay attention to the O-ring 145.
- Drain the operating fluid.
  - If the drained operating fluid is free of foreign material, it can be fed back to the rotary vane pump.

## 7.2 Changing and cleaning the filter insert

The filter insert must be exchanged or cleaned when the exhaust pressure increases until the pressure relief valve opens inside the ONF and oil mist exits.

### Dismantling

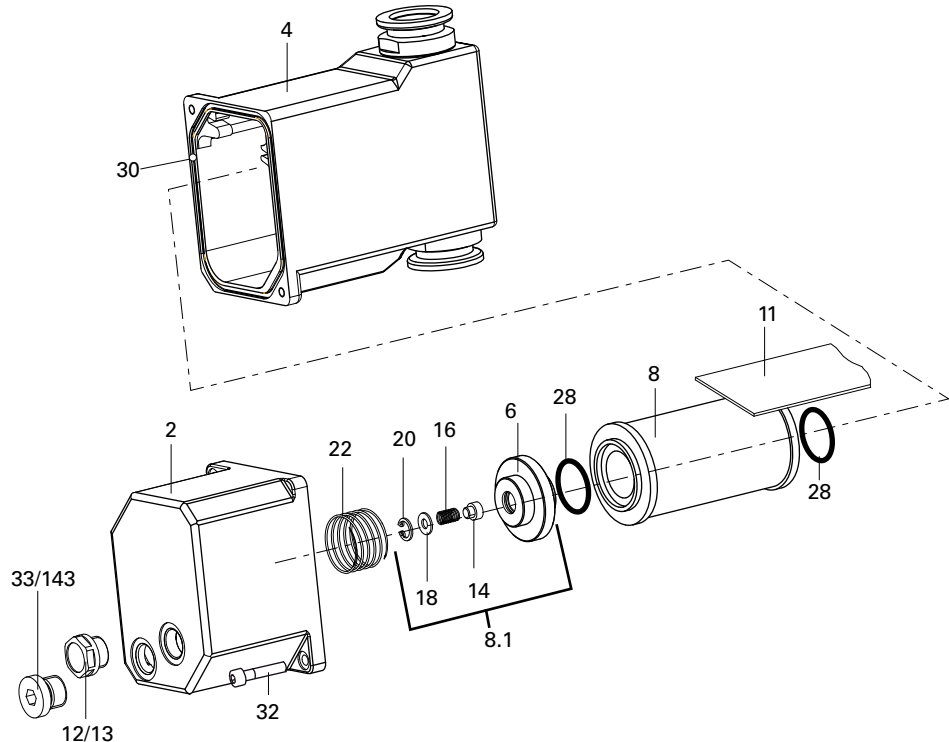

**Fig. 5: ONF 16/25/25 L (with ONF 25 XL 8.1 is a part of 8)**

2	Casing	12	Sight glass	22	Compression spring
4	Cover	14	Valve buffer	28	O-ring
6	Casing of pressure relief valve	16	Pressure spring	30	O-ring
8	Filter insert	18	Washer	32	Screw
11	Deflector	20	Circlip	33	Operating fluid drain screw

- Switch off the pump, vent it to atmospheric pressure and let it cool down.
- Unscrew operating fluid drain screw 33.
- Drain operating fluid.
  - If the drained operating fluid is free of contamination, it can be fed back to the rotary vane pump.
- Remove ONF from the system and pour out the remaining operating fluid.
- Unscrew and remove the screws 32 and carefully detach the housing 2 from the cover 4;
  - Caution! The parts are under preload.
- Detach casing 2 and filter insert 8 and all other internally located parts from cover 4; take care with o-rings 30 and 28 (not with ONF 25 XL).
- Replace or clean the filter insert and re-assemble the parts in reverse order.

### Dismantling the pressure relief valve

The pressure relief valve 8.1 at the ONF 25 XL is integrated in the filter insert 8 and cannot be dismantled.

- Loosen circlip 20 with pliers and dismantle washer 18, spring 16 and valve buffer 14 from valve housing 6.
- Clean all parts and inspect for wear.
- Check the sealed surface of valve buffer 14; replace if necessary.

- When assembling lightly oil valve buffer and ensure the correct seating in the valve housing.

## Cleaning



### WARNING

#### Explosion hazard

The use of volatile or combustible cleaning agents in vacuum systems can lead to explosive vapour-air mixtures.

→ After cleaning ventilate and dry components adequately and let dry completely.

→ Let the filter insert remain for approx. 12 h in solvent.

→ Use air under slight pressure to eject the solvent from the filter inserts, and then dry them.

## Assembling

Continue assembly by reversing the dismantling sequence, paying particular attention to compliance with the following steps.

→ Put up cover 4, opening facing upwards.

→ Lightly oil O-ring 28 (seal at ONF 25XL).

→ When mounting casing 2 ensure the correct seating of the filter insert 8 and of the pressure relief valve casing; in particular take care with regard to the position of compression spring 22 and O-rings 28 and 30.

## 8 Service

### **Pfeiffer Vacuum offers first-class service!**

- Fast replacement with exchange products in mint condition
- Advice on the most cost-efficient and quickest solution

Detailed information, addresses and forms at: **[www.pfeiffer-vacuum.net](http://www.pfeiffer-vacuum.net) (Service)**.

### **Maintenance and repairs in the Pfeiffer Vacuum ServiceCenter**

The following steps are necessary to ensure a fast, smooth servicing process:

- ➔ Download the forms "Service Request" and "Declaration on Contamination".<sup>1)</sup>
- ➔ Fill in the "Service Request" form and send it by fax or e-mail to your service address.
- ➔ Include the confirmation on the service request from Pfeiffer Vacuum with your shipment.
- ➔ Fill in the declaration on contamination and include it in the shipment (required!).
- ➔ Drain off operating fluid.
- ➔ If possible, send pump or unit in the original packaging.

### **Sending of contaminated pumps or devices**

No units will be accepted if they are contaminated with micro-biological, explosive or radioactive substances. "Hazardous substances" are substances and compounds in accordance with the hazardous goods directive (current version). If pumps are contaminated or the declaration on contamination is missing, Pfeiffer Vacuum performs decontamination at the shipper's expense.

- ➔ Neutralise the pump by flushing it with nitrogen or dry air.
- ➔ Close all openings airtight.
- ➔ Seal the pump or unit in suitable protective film.
- ➔ Return the pump/unit only in a suitable and sturdy transport container and send it in while following applicable transport conditions.

### **Service orders**

All service orders are carried out exclusively according to our repair conditions for vacuum units and components.

<sup>1)</sup> Forms under [www.pfeiffer-vacuum.net](http://www.pfeiffer-vacuum.net)

## 9 Accessories

Oil return unit	ONF 16	ONF 25	ONF 25 L	ONF 25 XL
ORF from ONF 16 to UNO 2.5, DUO 2.5, UNO 5	PK 194 315 -T			
ORF from ONF 16 to DUO 5 M	PK 196 172 -T			
ORF from ONF 25 to DUO 10 M		PK 196 172 -T		
ORF from ONF 25 L to DUO 20 M, TWIN 20-10			PK 196 172 -T	
ORF from ONF 25 L to UNO 30 M			PK 196 944 -T	
ORF from ONF 25 to Penta 10		PK 198 545 -T		
ORF from ONF 25 L to Penta 20			PK 198 545 -T	
ORF from ONF 25 XL to Penta 35				PK 198 545 -T

## 10 Technical data

Parameter	ONF 16	ONF 25	ONF 25 L	ONF 25 XL
Degree of separation	99.98	99.98	99.98	99.98
Flange (in)	DN 16 ISO-KF	DN 25 ISO-KF	DN 25 ISO-KF	DN 25 ISO-KF
Flange (out)	DN 16 ISO-KF	DN 25 ISO-KF	DN 25 ISO-KF	DN 25 ISO-KF
Capacity	0.15 l	0.15 l	0.25 l	0.35 l
For pumping speed	2.5-5 m <sup>3</sup> /h	10 m <sup>3</sup> /h	30 m <sup>3</sup> /h	34 m <sup>3</sup> /h
Weight	1.35 kg	1.4 kg	1.6 kg	1.9 kg

## 10.1 Dimensions

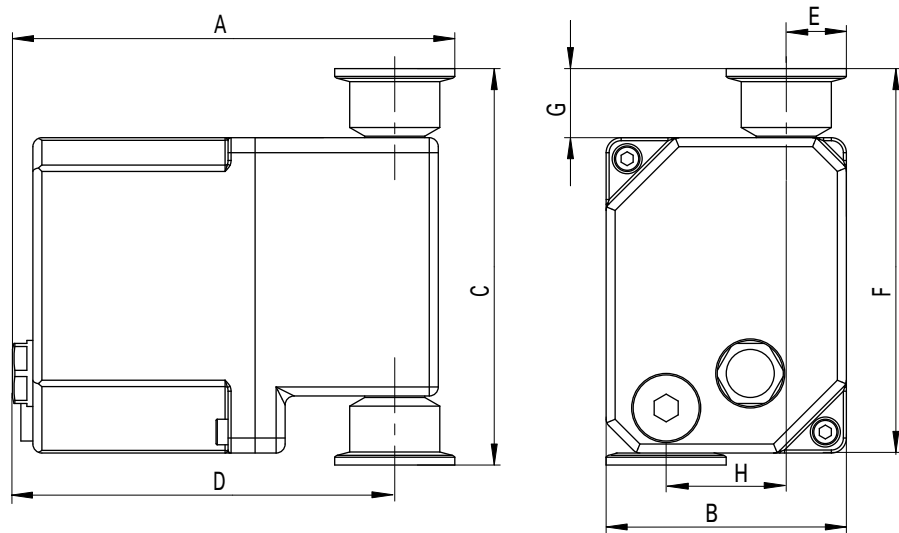

**Fig. 6: ONF 16/25/25 L**

Dimensions	ONF 16	ONF 25	ONF 25 L
A	142 mm	147 mm	218 mm
B	80 mm	80 mm	80 mm
C	120 mm	132 mm	134 mm
D	127 mm	127 mm	182 mm
E	16 mm	16 mm	25 mm
F	105 mm	105 mm	105 mm
G	17 mm	23 mm	27 mm
H	48 mm	48 mm	- mm

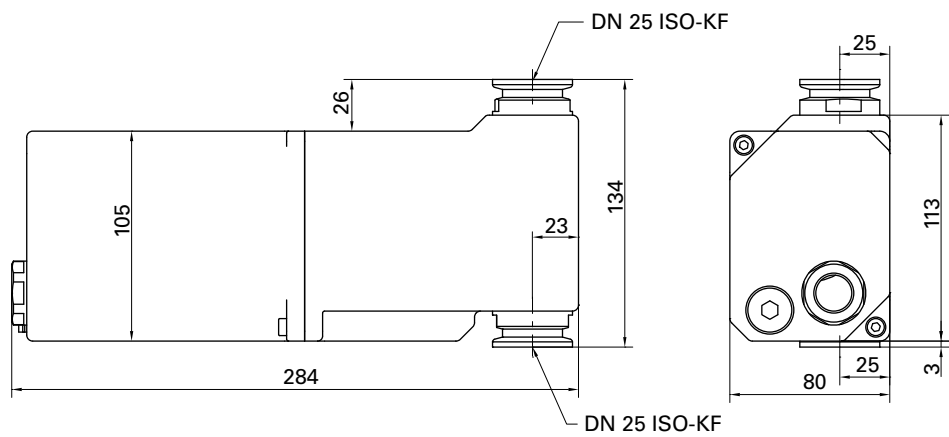

**Fig. 7: ONF 25 XL**

# 11 Spare parts

The spare parts packages listed here are only applicable for standard models. Please state all information on the rating plate when ordering spare parts. Other spare parts than those described in this manual must not be used without the agreement of Pfeiffer Vacuum.

## 11.1 Spare parts packages

Spare parts package	Model	No.	Consisting of
Maintenance kit	ONF 16	PK E37 001 -T	8, 30
	ONF 25	PK E37 001 -T	8, 30
	ONF 25 L	PK E37 003 -T	8, 30
Overhaul kit	ONF 25 XL	PK E37 100 -T	8,30
	ONF 16	PK E37 002 -T	8, 12, 13, 14, 16, 18, 20, 22, 30, 33
	ONF 25	PK E37 002 -T	8, 12, 13, 14, 16, 18, 20, 22, 30, 33
	ONF 25 L	PK E37 004 -T	8, 12, 13, 14, 16, 18, 20, 22, 30, 33
	ONF 25 XL	PK E37 101 -T	8, 12, 22, 24, 30, 33

ONF 16/25/25 L

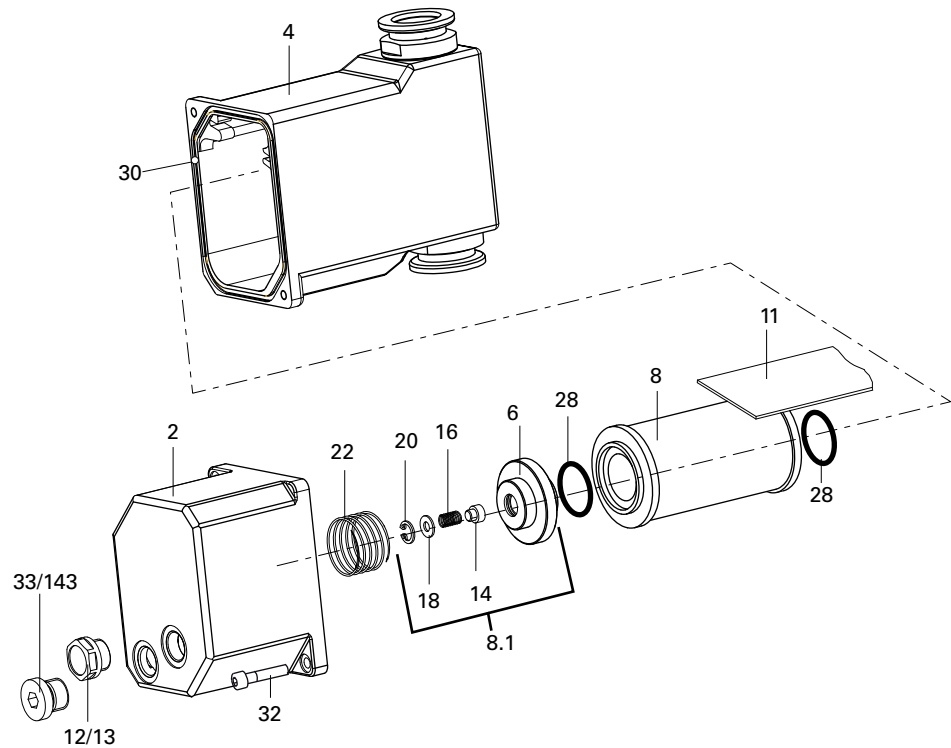
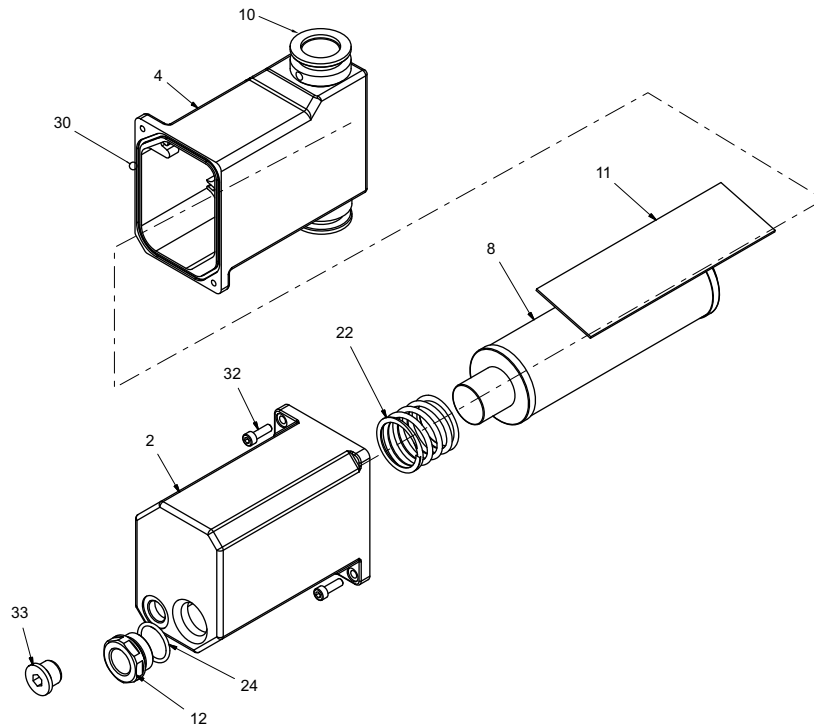

Fig. 8: ONF 16/25/25 L



## ONF 025 XL

**Fig. 9: ONF 025 XL**

## 12 Disposal

Products or parts thereof (mechanical and electrical components, operating fluids, etc.) may cause environmental burden.

→ Safely dispose of the materials according to the locally applicable regulations.



**Vacuum is nothing, but everything to us!**



**Turbopumps**



**Rotary vane pumps**



**Roots pumps**



**Dry compressing pumps**



**Leak detectors**



**Valves**



**Components and feedthroughs**



**Vacuum measurement**



**Gas analysis**



**System engineering**



**Service**

**PFEIFFER**  **VACUUM**

Pfeiffer Vacuum Technology AG · Headquarters/Germany

Tel. +49-(0) 64 41-8 02-0 · Fax +49-(0) 64 41-8 02-2 02 · [info@pfeiffer-vacuum.de](mailto:info@pfeiffer-vacuum.de) · [www.pfeiffer-vacuum.net](http://www.pfeiffer-vacuum.net)